



Systems Reference Library

IBM System/360 Disk Operating System System Generation and Maintenance

This reference publication describes the specifications and operating procedures for generating an installation-tailored Disk Operating System. With the IBM-supplied Disk Operating System and an IBM 2311 Direct Access Storage Device, or an IBM 2314 Direct Access Storage Facility, a Disk Operating System can be generated that supports those IBM-supplied programs desired by the user, in addition to his own programs.

With the storage requirements provided, an installation-tailored Disk Operating System can be planned. With the sample problems provided, the generated system can be tested. A thorough understanding of IBM System/360 Disk Operating System concepts and machine facilities are prerequisites to the effective use of this manual. Major topics discussed in detail are:

- Planning an Operational Pack
- System Generation and Maintenance
 - Macro Instructions for Generating a Supervisor
 - Maintenance Procedures
- Sample Problems
- Storage Requirements

Prerequisites to a thorough understanding of this manual are:

IBM System/360 Disk Operating System, System Control and System Service Programs, Form C24-5036

IBM System/360 Disk Operating System, Supervisor and Input/Output Macros, Form C24-5037

IBM System/360 Disk Operating System, Operating Guide, Form C25-5022

IBM System/360 Disk and Tape Operating Systems, Utility Programs Specifications, Form C24-3465

IBM System/360 Basic Programming Support, DASD Utility Programs Specifications, Form C24-3363

For titles and abstracts of other associated publications, see the IBM System/360 Bibliography, Form A22-6822.

Eighth Edition (April 1969)

This edition applies to Release 20 of IBM System/360 Disk Operating System and to all subsequent releases until otherwise indicated in new editions or Technical Newsletters. Changes are continually made to the specifications herein; before using this publication in connection with the operation of IBM systems, consult the latest System/360 SRL Newsletter, Form N20-0360, for the editions that are applicable and current.

This edition, C24-5033-7, is a major revision of, and obsoletes, C24-5033-6.

Summary of Amendments

This edition reflects support for:

- Overlapping of I/O with processing for both the load and sequential retrieve functions for indexed sequential files.
- The capability of returning additional unrecoverable I/O errors to the problem program using the direct access, sequential disk, indexed sequential and magnetic tape macro functions.
- The 1401/1440/1460 Emulator Program for the IBM System/360 Model 40 and Model 25.
- The librarian copy and organize program extension that allows merging of libraries.
- PL/I Version 4.
- ETAM and QTAM in a multitasking environment.
- COBOL improvements for Indexed Sequential File Management

Maintenance changes and technical corrections are also included.

The storage estimates, formerly published in IBM System/360 Disk Operating System Performance Estimates, Form C24-5032, are now published in Appendix G of this manual.

Changes are indicated by a vertical line to the left of affected text and to the left of affected parts of figures. A dot (•) next to a figure title or page number indicates that the entire figure or page should be reviewed.

Requests for copies of IBM publications should be made to your IBM representative or to the IBM branch office serving your locality.

A form for readers' comments is provided at the back of this publication. If the form has been removed, comments may be addressed to IBM Corporation, Programming Publications, Endicott, New York 13760.

Preface

This publication guides the user through the generation of an installation-tailored Disk Operating System for IBM System/360. The information herein is of particular interest to anyone who wants to build a Disk Operating System, including installation managers, system analysts, programmers and machine operators.

In particular, the user will find that familiarity with the following system programs and facilities is invaluable when using this publication: the control program, the system service programs, and the input/output control system (IOCS) logic modules. The control program, and the system service programs are described in the System Control and System Service Programs publication. The IOCS logic modules are described in the Supervisor and Input/Output Macros publication, both of which are listed on the front cover.

The publication is divided into the following major sections, and seven appendixes:

1. Introduction
2. Planning an Operational Pack
3. System Generation and Maintenance Procedure
4. IBM BPS Utility Programs
5. Macro Instructions for Generating a Supervisor
6. Two 2311 Disk Drives
7. One 2311 Disk Drive
8. IBM 2314 Direct Access Storage Facility
9. Maintenance Procedures
10. Disk Operating System Sample Problems

The first five sections contain required information for most users. Sections six, seven, and eight refer to specific machine configurations, and present techniques for generating a system. They are examples intended to guide the user through the generation of his system. Only the section that relates to the user's configuration need be read.

Section nine describes maintenance procedures and how to apply IBM-supplied

Disk Operating Systems to maintain an existing Disk Operating System.

Section ten describes the IBM-supplied sample problems that can be used to test a system after it is generated.

The appendixes contain information needed for planning a Disk Operating System. Appendix B, IOCS Modules for COBOL, RPG, and PL/I; Appendix C, IBM System Components Identification; and Appendix G, Storage Requirements are of major importance for planning purposes. Appendixes B and C will assist the user when planning the contents of his libraries, and Appendix G when estimating the size of his supervisor, and libraries.

Closely related publications are:

IBM System/360 Disk Operating System, Timing Estimates, Form C24-5032

IBM System/360 Disk Operating System, Vocabulary File Utility Programs for IBM 7772 Audio Response Unit, Form C27-6924

IBM System/360 Basic Programming Support, Distribution Program Specifications and Operating Guide, Form C21-5001

IBM System/360 Basic Programming Support, DASD Utility Programs Operating Guide, Form C24-3392

References are made in this publication to the following:

IBM System/360 Disk and Tape Operating Systems, COBOL Programmer's Guide, Form C24-5025

IBM System/360 Disk Operating System, FORTRAN IV Programmer's Guide, Form C28-6397

IBM System/360 Disk and Tape Operating Systems, Basic FORTRAN IV Programmer's Guide, Form C24-5038

IBM System/360 Disk and Tape Operating Systems, PL/I Programmer's Guide, Form C24-9005

IBM System/360 Disk Operating System 1401/1440/1460 Emulator Programs for IBM System/360 Models 30 and 40; Compatibility Support/30; Compatibility Support/40, Form C27-6940

IBM System/360 Disk Operating System Autotest, Form C24-5062.

Contents

INTRODUCTION	7	MAINTENANCE PROCEDURES	97
Planning System Generation	7	Using the MERGE Function of the CORGZ	
Planning the Libraries	8	Librarian Program	97
Core Image Library	8	Replacing Identical Entries Using	
Relocatable Library	9	MERGE Function	97
Source Statement Library	9	Adding Unique Entries Using MERGE	
Private Libraries	9	Function	97
Library Sizes	9	General Library Updating Techniques	
Allocating Library Sizes	10	using the MERGE Function of the CORGZ	
Planning a Supervisor	10	Librarian Program	97
System Configuration	10	Copying Selectively to Merge	
Machine Requirements	10	Libraries	97
PLANNING AN OPERATIONAL PACK	12	Deleting Unwanted Entries and	
Background Partition Storage		MERGING an Entire Library with	
Requirements for Disk Operating		Another Library	98
System IBM-Supplied Programs	12	Copying Selectively Merging Two	
One 2311 Disk Drive	13	Libraries to Create a Third Library .	98
At Least Two 2311 Disk Drives or a		Deleting Unwanted Entries from Two	
2314 Direct Access Storage Facility .	14	Libraries and Merging Both Libraries	
Allocating Library Sizes for 2311		to Create a Third Library	98
and 2314 Disk Systems	14	Conventions for Merge Examples	98
User Decisions and Considerations .	16	Maintenance Examples using MERGE	
Variants of IBM-Supplied Assembler .	17	Function	99
Variants of PL/I	18	Example 1A: Copying Selectively to	
PL/I and System Input/Output on Disk .	18	Merge Two Libraries	99
Warning Diagnostics	20	Example 1B: Variation of Selective	
SYSTEM GENERATION AND MAINTENANCE		Copying to Merge Two Libraries	100
PROCEDURE	22	Example 2A: Deleting Unwanted	
IBM BPS UTILITY PROGRAMS	27	Entries from A Library and Merging	
Copy and Restore	27	Libraries by Copying One to the Other	100
Distribution Program 360P-UT-208	28	Example 2B: Variation of Deleting	
Copying a System Tape to Disk	29	Unwanted Entries from A Library and	
Restoring a System Tape to Disk	29	Copying (Merging) One to the Other .	100
Initialize Disk	29	Example 3: Copying Selectively,	
MACRO INSTRUCTIONS FOR GENERATING A		Merging Two Libraries to Create a	
SUPERVISOR	33	Third Library	101
Rules for Using Supervisor		Example 4: Deleting Unwanted Entries	
Generation Macros	33	from Two Libraries and Merging Both	
TWO IBM 2311 DISK DRIVES	52	Libraries to Create a Third Library .	101
Input/Output Device Configuration		Considerations for Merging	102
for Example One (See Figure 7)	55	DISK OPERATING SYSTEM SAMPLE PROBLEMS	105
Example One: Results of System		Retrieving the Sample Problems	105
Generation	55	Physical and Logical I/O Assignments .	109
ONE IBM 2311 DISK DRIVE	71	Tape, Disk, and Data Cell	
Input/Output Device Configuration		Configurations	110
for Example Two (See Figure 9)	74	Examples of Sample Problem Execution	
Example Two: Results of System		and Output	116
Generation	74	Multiprogramming	195
IBM 2314 DIRECT ACCESS STORAGE		APPENDIX A. IPI CONTROL AND ASSGN	
FACILITY	87	STATEMENTS FOR SYSTEM GENERATION	222
Input/Output Device Configuration		ADD (Add a Device)	222
for Example Three (See Figure 11)	88	SET (Set the Date)	223
Example Three: Results of System		ASSGN (Assign Logical Name)	223
Generation	89	AIT	224
		APPENDIX B. IOCS MODULES FOR COBOL,	
		RPG, AND PL/I	225

APPENDIX C. IBM SYSTEM COMPONENTS	
IDENTIFICATION233
Core Image Phases233
Relocatable Module Identification238
Telecommunications257
BTAM Relocatable Module and Core	
Image Phase Identification257
QTAM Relocatable Module and Core	
Image Phase Identification262
Preassembled Modules Used to Build	
IBM Components269
 APPENDIX D. DISK SORT/MERGE MODULES277
Primary Processor Generation Books278
Intermediate Processor Generation Books	279
Phase Names and Relocatable Module	
Names281
 APPENDIX E. TAPE AND DISK SORT/MERGE	
MODULES282
Primary Processor Generation Books283
Intermediate Processor Generation Books	283
Phase Names and Relocatable Module	
Names293
 APPENDIX F. BPS DEVICE TYPE	
SPECIFICATIONS (DD)295
 APPENDIX G. STORAGE REQUIREMENTS296
Internal Storage Requirements296
Supervisor296
Computing the Size of a Supervisor303
Supervisor Macro Instructions304
Foreground Save Areas306
MPS Utility Macro Instructions306
IOCS Declarative Macro Instructions306
DTFCD (Define the File: Card)309
CDMOD (Card Module)310
DTFCN (Define the File: Console)311
DTFDA (Define the File: Direct	
Access Device)311
DAMOD (Direct Access Device Module)312
DTFIS (Define the File: Indexed	
Sequential)312
ISMOD (Indexed Sequential Module)313
DTFMR (Define the File: Magnetic	
Character Reader)315
MRMOD (Magnetic Character Reader	
Module)315
DTFDI (Define the File: Device	
Independent System Units)315
DIMOD (Device Independent System	
Units Modules)315
DTFMT (Define the File: Magnetic	
Tape)315
MTMOD (Magnetic Tape Module)317
DTFOR (Define the File: Optical	
Reader)317
ORMOD (Optical Reader Module)318
DTFPH (Define the File: Physical	
IOCS)318
DTFPR (Define the File: Printer)318
PRMOD (Printer Module)319
DTFPT (Define the File: Paper Tape	
Reader)319
PTMOD (Paper Tape Reader Module)319
DTFSR (Define the File: Serial	
Device)321
DTFBT (Define the File: BTAM)321
DTFBTND (Define the File End: BTAM)323
DTFTRLST (Define the Terminal List:	
BTAM)323
BTMOD (BTAM Logic Module)325
BTAM Data Event Control Block326
QTAM Storage Requirements326
Basic QTAM Logic Modules326
DTFQT (Define the File: QTAM)327
QTAM Storage Requirements for Control	
Information329
QTAM Requirement for Buffers330
QTAM Storage Requirements for Device	
I/O Modules331
Requirements for Other QTAM Macro	
Instructions332
Other IOCS Macro Instructions338
Relocatable Subroutine342
COBOL Subroutines342
FORTRAN Subroutines345
Basic FORTRAN Subroutines346
PL/I Subroutines347
IOCS Modules For The Compilers349
External Storage Requirements356
Core Image Library358
Relocatable Library360
Source Statement Library361
Workfile Requirements365
Workfile Requirements for Linkage	
Editor and Assembler (IBM 2311 and	
IBM 2314)365
Assembler Workfiles365
IBM 2311 Workfile Requirements370
Autotest Work Area (IBM 2311)371
COBOL Workfiles (IBM 2311)371
FORTRAN Workfiles (IBM 2311)371
PL/I Workfiles (IBM 2311)371
RPG Workfiles (IBM 2311)371
IBM 2314 Workfile Requirements372
COBOL Workfiles (IBM 2314)372
FORTRAN Workfiles (IBM 2314)372
PL/I Workfiles (IBM 2314)372
RPG Workfiles (IBM 2314)372
Optimum Assignment of Workfiles373
 INDEX378

Introduction

The IBM System/360 Disk Operating System for 2311 resident systems is supplied to the user in two volumes. The volumes can be identified as a relocatable volume and a source statement volume. Users with a tape unit available receive the volumes on tape reels; users without a tape unit available receive the volumes on disk packs. These volumes are manipulated during system generation to create an operational system.

IBM supplies the 2314 system on two tape reels. These tapes will be restored to a 2314 disk pack to create a system consisting of a core image library, a relocatable library, and a source statement library. The capacity of one 2314 disk pack is enough to accommodate both tape reels shipped by IBM.

The disk operating system is composed of three libraries:

Source Statement Library

Relocatable Library

Core Image Library

The source statement library contains IBM-supplied macro definitions. When the desired parameters are chosen, the macros can be assembled. For the user's convenience, the source statement library also contains sample problems and system generation job streams that can be retrieved as needed.

The relocatable library contains IBM programs that have not been assigned addresses for execution and assembled macros from the source statement library. These assembled macros perform input and output procedures for IBM-supplied programs. These assembled macros (Logical IOCS modules) can also be used by user programs when applicable.

The core image library contains programs that are ready for execution. System control programs and system service programs are always shipped to the customer in the core image library. Where it is necessary for system generation purposes, an assembler program is provided. The system control programs must always be part of the system. The librarian programs are a key set to the system and should be carefully considered before ever removing them from the system.

During system generation the user works with the IBM-supplied system to tailor it to his individual needs. This consists of adding to and deleting from the libraries, IBM and user code (source, relocatable and core image).

Planning System Generation

Proper and detailed planning saves on total system generation time. Thus, it is very important to perform a very thorough job.

Planning system generation consists of:

1. Planning the contents, organization, and ultimate size of the system and/or private libraries. This entails distributing the storage space available (on the disk packs) between the libraries ultimately desired for day-to-day use. Major points of consideration are:

- the size of the core image library and, if desired, system and/or private relocatable and source statement libraries
 - workfile space needed to assemble a supervisor, and to accommodate the linkage editor, which is needed to catalog the components selected to the system core image library
 - standard assignments (allocation of space) for workfiles (assemblies), and linkage editing needed for every day operation.
2. Planning the contents and estimating the size of a supervisor. This entails selecting from the programming services provided by IBM, those to be included in the supervisor, and estimating the cost of these services in terms of bytes of storage.

PLANNING THE LIBRARIES

Two types of IBM libraries are:

1. System libraries
2. Private libraries

The system libraries are the core image, the relocatable, and the source statement. The private libraries are the private relocatable, and the private source statement library. (There is no private core image library.)

CORE IMAGE LIBRARY

Because the core image library contains the executable format of programs, it is the library in which the user is most likely to keep his programs. Otherwise, the programs must continually be placed in the core image library before each execution (linkage edited). Therefore, during system generation the user expands the size of the core image library to accommodate all the programs desired resident and on-line. (Both his own programs and IBM's.)

In addition, the user should try to envision future space he may require, and provide this space if possible. Such planning can eliminate the need for another system generation. Thus, to expand the core image library means making the remaining libraries smaller on the pack.

Before the size of a library is reduced, the user must delete those items that are not to be used, or those items that were transferred to another library in the required format. It is recommended that backup of the system (a copy of the IBM-supplied system) be obtained to protect a user who accidentally removed something he desired from the system. It is also recommended that after successful completion of segments of system generation, a copy (backup) of the partially generated system be obtained, i.e., upon the creation of a library, or the assembly of a supervisor. This permits a user to return to a point other than the beginning of his procedure in case of an error. The components supplied in the IBM-shipped core image library facilitate system generation.

RELOCATABLE LIBRARY

All IBM-supplied components are shipped in the relocatable library. This library is the basis for the creation of a private relocatable library. Thus, it is from this library that most IBM components are directly or indirectly extracted (indirectly in the case of the existence of a private relocatable library and a system relocatable library).

SOURCE STATEMENT LIBRARY

All IBM-supplied macro definitions are in this library. This library is the basis for the creation of a private source statement library. Thus, it is from this library that many users extract, directly or indirectly, IBM-supplied component macro definitions (indirectly in the case of the existence of both a private source statement library, and a system source statement library).

PRIVATE LIBRARIES

If the user has more than one disk drive available, it is not necessary to decrease the size of the relocatable and source statement libraries. They can be assigned to other disks and are then referred to as private libraries. The user can build systems with private and system libraries containing those items that best fit his needs.

LIBRARY SIZES

The user must choose which of the libraries he desires, and then plan their precise content and size for daily use. Thus, the user should know the initial, intermediate, and final sizes of the libraries throughout system generation, and he must plan the exact contents of each library that is created during system generation. These contents should be listed, along with their sizes, and then the total number of cylinders to be allocated can be calculated.

The contents of the libraries are identified in Attachment 1 of the Memorandum To Users that accompanies the IBM system that is shipped. The storage requirements (sizes) for these components, and macro definitions are identified in Appendix G: Storage Requirements. Components shipped in the relocatable library are also identified in Appendixes B, C, D, and E. Those macro definitions supplied by IBM are also identified in Appendix C.

An alternate method for determining the number of cylinders to allocate for a library is given in the discussion Allocating Library Sizes for 2311 and 2314 Disk Systems. Note that once private library sizes have been allocated, they cannot be reallocated. Although excess room in the libraries may not offer maximum efficiency, in case of a calculation error, the benefits can be easily recognized when sufficient space is available.

ALLOCATING LIBRARY SIZES

When the user desires to reduce the size of an existing library, it may be important to know the minimum library size that can be allocated. This size should be increased to accommodate any additional user programs to be included in this library. The size of any IBM component to be included in this library can be determined by referring to the storage requirements given in Appendix G. For the details on how to allocate an existing library, see Allocating Library Sizes for 2311 and 2314 Disk Systems.

PLANNING A SUPERVISOR

The supervisor is a control program that provides specialized services to programs executed from the problem program area of main storage. This program is composed of a group of assembled macros (see Macro Instructions for Supervisor Generation). The options selected in each of the supervisor generation macros determine the size of the assembled supervisor. The size of each option is identified in Appendix G.

The SEND macro determines the end of the supervisor. If the user assembles a supervisor with a SEND address larger than the previous supervisor, some portion of the supervisor is overlaid by programs linkage edited to the previous SEND address.

The user must re-linkage edit programs after the new supervisor is loaded so that the new load address follows the newly assembled supervisor.

Note that at each IPL, the user must include ADD and ASSGN statements for each device until a system supervisor is built that describes his machine configuration and standard I/O assignments (see DVCGEN and ASSGN macros).

To calculate the size of the supervisor the user must list all of the options that are chosen and then determine the sum of the sizes obtained from the storage requirements (see Appendix G).

When choosing supervisor parameters, the user must check to see if the chosen options are compatible. Also, the user should check to determine which parameters automatically provide the support for another.

System Configuration

This section presents the minimum system configuration required to operate the Disk Operating System. The system control programs and basic IOCS must always be present in order to execute any other programs.

MACHINE REQUIREMENTS

Minimum features required:

16K bytes of main storage

Standard instruction set. See Note 1.

One I/O channel (either multiplexor or selector). See Note 2.

One Card Reader (1442, 2501, 2520, or 2540). See Note 3.

One Card Punch (1442, 2520, or 2540). See Note 3.

One Printer (1403, 1404, or 1443). See Note 3.

One 1052 Printer-Keyboard.

One 2311 Disk Storage Drive or

One 2314 Direct Access Storage facility

Note 1: Language translators may require extended instruction sets.

Note 2: Telecommunications requires a minimum of two channels, one multiplexor channel, and at least one selector channel. One channel is required for telecommunications, and the other for the system resident device. (Telecommunication devices should not be on the same selector channel as SYSRES.) Note that a 2701 Line Adapter Unit attached to an IBM System/360 Model 2025 must be placed on the multiplexor channel.

Note 3: One 2400-series magnetic tape unit may be substituted for this device (7- or 9-track). If 7-track tape units are used, the data-convert feature is required, except when substituted for a printer.

Planning an Operational Pack

An operational system is one used in day-to-day operations that contains a tailored supervisor and libraries appropriate to each customer's particular combination of system programs and application programs. A system maintenance volume is one used primarily to facilitate changes to programs supplied by IBM. Application programs can also be added to a maintenance volume for ease of program maintenance.

Change Distributions are those changes supplied by IBM to the IBM-shipped volume.

Proper planning is the key to successful system generations. The time spent in planning can save the user frustration and valuable time. The user's planning should reflect the initial, intermediate and ultimate capacity of the core image, relocatable and source statement libraries. Enough workfile capacity must be available throughout system generation for assemblies and linkage-edit steps.

Appendix G should be used to determine storage requirements for the components in the system.

IBM supplies a system containing either a 6K for 2311, or 8K for 2314 supervisor. The IBM supervisors are those described in Figure 6.

BACKGROUND PARTITION STORAGE REQUIREMENTS FOR DISK OPERATING SYSTEM IBM-SUPPLIED PROGRAMS

All IBM-supplied programs used with Disk Operating System that are language translators or utilities execute in the background partition. Figure 1 lists the minimum size background partition required.

<u>IBM-Supplied Program</u>	<u>IBM-Program Number</u>	<u>Minimum Size Background Partition (in bytes)</u>
Assembler (IJQD16TW) or (IJQD16DW)	360N-AS-465	10,240
Assembler (IJQD32)	360N-AS-465	14,336
Assembler (IJYASM)	360N-AS-466	45,056
COBOL	360N-CB-452	14,336
Basic FORTRAN	360N-FO-451	10,240
FORTTRAN	360N-FO-479	40,960
RPG	360N-RG-460	10,240
PL/I	360N-PL-464	10,240
Utilities		
Group 1	360N-UT-461	10,240
Group 2	360N-UT-462	10,240
Group 3	360N-UT-463	10,240
Tape Sort/Merge	360N-SM-400	10,240
Disk Sort/Merge	360N-SM-450	10,240
Tape/Disk Sort/Merge	360N-SM-483	
Tape/2311		10,240
2314		22,528
1401/1440/1460 Emulator for IBM Model 30	360N-EU-484	16,384
1401/1440/1460 Emulator for IBM Model 40	360N-EU-485	*
Autotest	360N-PT-459	10,240

* The background partition storage requirement is as follows:
16,384 bytes for the supervisor plus 2,048 to 16,384 bytes for the 1400
being emulated plus the size of the emulator program defined.

● Figure 1. Disk Operating System Background Partition Storage Requirements for IBM-Supplied Programs

ONE 2311 DISK DRIVE

When the user plans his operational system he decides upon the ultimate appearance of his libraries. The one disk drive user will find it most convenient to build his operational system on the IBM volume that contains the core image and relocatable libraries. Many single disk drive users will want to build operational systems appearing as one of the following:

- Core image library, small system relocatable library, and/or small system source statement library
- Large core image library

The small system relocatable library is for users who need the compiler subroutines and/or system IOCS modules on line at all times. If the subroutines are to be on line, the relocatable library should also have enough room to contain the user's largest compiler.

The small system source statement library can contain system control and logical IOCS macros. The system with the source statement library, supplied by IBM, can be used as an assembly pack.

AT LEAST TWO 2311 DISK DRIVES OR A 2314 DIRECT ACCESS STORAGE FACILITY

The user with at least two disk drives will find it most convenient to build his operational pack upon the IBM volume that contains the core image and source statement libraries. Many multiple disk drive users will want to build operational system appearing as one of the following:

- Core image library, private relocatable, and private source statement libraries.
- Core image library, private relocatable library, system source statement library, and private source statement library.
- Core image library, system relocatable library, private relocatable library, and private source statement library.
- Core image library, system relocatable and source statement libraries, and private relocatable and source statement libraries.
- Core image library, system relocatable and system source statement libraries.
- Core image library, system source statement library, small private relocatable library (on the operational pack) and private relocatable library.

IBM system control and system service programs are supplied in the core image libraries of both volumes for the 2311 systems and in the core image library for the 2314 system. The 2311 systems have the 10K background disk workfile assembler supplied in the core image library of the source statement library volume. The 2314 systems have the 14K background disk and tape workfile assembler in the core image library. For both 2311 and 2314 systems, all IBM components are supplied in the relocatable library.

If the user's assembled supervisor does not exceed the size of the IBM supervisor, re-linkage editing and re-cataloging of the IBM-supplied programs shipped in the core image library are unnecessary. Job control is self-relocating and need never be re-linkage edited. Only the steps required to retrieve the sample problems, delete unwanted components, assign standard labels, assemble a user's supervisor, allocate for and linkage edit IBM components, and condense libraries are necessary to perform system generation.

When the number of tracks required for each library has been calculated, the user should allocate a sufficient number of cylinders to each library of each operational system. Additional cylinders may be allocated to the core image library for application programs. Sometimes the user must reallocate the libraries on his disk pack(s) during system generation to ensure sufficient work file storage for assemblies and linkage-edit steps.

Users with more than one available disk drive will find it to their advantage during system generation to define private relocatable and source statement libraries for an operational system.

ALLOCATING LIBRARY SIZES FOR 2311 AND 2314 DISK SYSTEMS

When the size of an existing library is reduced, it may be important to know the minimum size library that can be allocated. Once the minimum size library is calculated, it should be increased to accommodate any user programs to be included in the library. The size of IBM components can be determined by referring to the storage requirements given in Appendix G.

The following explanation illustrates how to calculate the number of tracks required for a core image, relocatable, or source statement library for a 2311 or 2314 disk system. The formula for computing the size of a library is:

$$\text{Library (size in tracks)} = \text{LBA}/\text{nn}$$

where: library = either core image, relocatable or source statement

LBA = the number of LIBRARY BLOCKS ACTIVE for the library of interest and is obtained from a DIRECTORY (SYSTFM or PRIVATE)

nn = LIBRARY LAST AVAILABLE ENTRY in the R (record) column

Using the sample PRIVATE DIRECTORY that follows, an example of how to compute a library size is:

$$\text{Relocatable Library} = \text{LBA}/\text{nn}$$

where: LBA = 9849
nn = 9 , thus

$$\text{Relocatable Library} = 9849/9 = 1,094.3 \text{ tracks}$$

The relocatable library size computed does not include the tracks allocated for the directory (see Directory Allocated Tracks). The directory size must be added to the relocatable library size computed. Thus,

$$\text{Relocatable Library Allocation} = \text{Relocatable Library} + \text{Directory Allocated Tracks}$$

Therefore,

$$\begin{aligned} \text{Relocatable Library Allocation} &= 1,094.3 + 9 \\ &= 1,103.3 \text{ Tracks} \end{aligned}$$

$$\text{For a 2311, cylinders} = \frac{\text{Library Size (Tracks)}}{10}$$

$$\text{For a 2314, cylinders} = \frac{\text{Library Size (Tracks)}}{20}$$

For this example,

$$\begin{aligned} \text{the Relocatable Library Allocation for a 2311} &= \frac{1103.3 \text{ Tracks}}{10} \\ &= 110.3 \text{ or } 111 \text{ cylinders,} \end{aligned}$$

rounded high

PRIVATE DIRECTORY

PRIVATE-RELOCATABLE

02/01/69

-----DECIMAL-----

		C	H	R	E
DIRECTORY	STARTING ADDRESS	01	00	01	
DIRECTORY	NEXT ENTRY	01	05	01	08
DIRECTORY	LAST ENTRY	01	08	09	19
LIBRARY	STARTING ADDRESS	01	09	01	
LIBRARY	NEXT AVAILABLE ENTRY	111	03	04	
LIBRARY	LAST AVAILABLE ENTRY	127	09	09	

STATUS INFORMATION

DIRECTORY	ENTRIES ACTIVE	903
LIBRARY	BLOCKS ALLOCATED	11349
LIBRARY	BLOCKS ACTIVE	9849
LIBRARY	BLOCKS DELETED	00
LIBRARY	BLOCKS AVAILABLE	1500
AUTOMATIC	CONDENSE LIMIT	00
LIBRARY	ALLOCATED CYLINDERS	127
DIRECTORY	ALLOCATED TRACKS	09

USER DECISIONS AND CONSIDERATIONS

The following considerations and decisions should be made before system generation:

1. Select supervisor options by coding a set of supervisor macro instructions (see Macro Instructions for Generating a Supervisor).
2. Determine which programs will be in the core image library of each operational pack (e.g. COBOL, FORTRAN, etc).
3. Determine which assembler will be used to generate a new supervisor. (See Variants of IBM-Supplied Assembler.) The 2311 systems have the 10K background disk workfile assembler supplied in the core image library of the source statement volume. The 2314 systems have the 14K background disk and tape workfile assembler supplied in the core image library.
4. Determine which modules are to be deleted from the relocatable library of each operational pack. Deleting from the relocatable library allows the user to expand the core image library to hold a greater number of components. Refer to Appendix G for IBM component sizes.
5. Users must also determine if the macro definitions used to build the supervisor and IOCS modules are to be deleted from the source statement library. Retaining the macros in the source statement library facilitates building a new supervisor and new user IOCS modules.

6. When possible, maintenance is supplied on magnetic tape or cards, rather than on disk packs. (Unusually large maintenance distributions are supplied on a disk pack to 2311 resident systems without magnetic tapes.) If a seven-track tape unit is to be used for systems maintenance, it must have the Data Conversion feature. The 2314 resident systems will always receive maintenance on tape.
7. One disk drive users may prefer to maintain only enough room in the relocatable library of the operational pack to contain the modules used to build the largest component in the system. This small relocatable library permits temporary insertion of any component in relocatable form. It can then be immediately linkage edited into the core image library and then deleted from the relocatable library. When the relocatable library is subsequently condensed, only the updated core image form of the component remains, thus conserving disk-storage capacity. Reducing the size of the relocatable library allows expansion of the core image library. The expanded core image library allows a greater number of components to be contained in a single systems volume.
8. Copy and restore programs are necessary to transfer the resident system from tape to 2311/2314, 2311/2314 to tape, 2311/2314 to cards, and cards to 2311/2314 for maintenance and backup purposes.
9. The procedures for the configurations shown in this publication assume the system packs to be initialized with the VTOC on cylinder 199 and the work packs to be initialized with the VTOC on cylinder zero or 199.

MAPS AND LISTINGS PRODUCED DURING SYSTEM GENERATION

All linkage editor output on SYSLST from the system generation procedure and any future updates (including maps produced by the linkage editor) must be retained. These maps provide necessary information on the level of the system and the load address (relocation) of each component. Similarly, supervisor assembly listings should be retained. These maps and listings will be used by the systems programmer and the Field Engineer maintaining the system.

VARIANTS OF IBM-SUPPLIED ASSEMBLER

The relocatable library of the IBM-supplied system residence contains assembler modules suitable for building an Assembler using Tape Work Files (TWF), or Disk Work Files (DWF), or both tape and disk workfiles. The following are the names of the IBM-supplied assembler variants:

- IJQD16TW (10K assembler, TWF)
- IJQD16DW (10K assembler, DWF)
- IJQD32 (14K assembler)
- IJYASM (44K assembler)

The first two variants require a minimum of 10K bytes of contiguous problem program storage for use by the assembler and can be used with a minimum machine size of 16K. The third variant of the assembler listed can be built to use either tape and/or disk work files and use additional problem program storage for buffering of work file input/output functions. The tape and/or disk work file variant requires a minimum of 14K bytes of contiguous problem storage for use by the assembler and requires a minimum machine size of 24K. A second assembler, Assembler F, is also available. This assembler requires a minimum of 44K bytes of contiguous storage and requires a minimum machine size of 64K. Either the 14K variant or the 44K Assembler must be used when using private source statement libraries.

The names of the 10K and 14K modules begin with IJQ and the 44K modules with IJY; thus modules can be copied, punched, or deleted by a COPYR, PUNCH, or DELETR statement specifying IJQ.ALL or IJY.ALL as an operand. To linkage edit the TWF only variant of the assembler, use the following job control statements:

```
    INCIUDE IJQD16TW
// EXEC    LNKEDT
```

To linkage edit the DWF only variant, use the following job control statements:

```
    INCLUDE IJQD16DW
// EXEC    LNKEDT
```

To linkage edit the 14K variant, use the following job control statements:

```
    INCLUDE IJQD32
// EXEC    LNKEDT
```

To linkage edit the 44K assembler, use the following job control statements:

```
    INCIUDE IJYASM
// EXEC    LNKEDT
```

If the 14K variant of the assembler is to be linkage edited to the core image library of a system containing a 10K variant, the assembler supplied in the core image library of the IBM-supplied pack should first be deleted (DELETC ASSE.ALL).

Only one of the IJQ variants may reside in the core image library at any one time. One of the IJQ variants can co-reside with the IJY assembler if the name of the first phase of one of them is changed from ASSEMBLY to some other name by means of the RENAMC function of the MAINT program. The renaming must be performed before the second assembler is linkage edited into the core image library. The first one is then invoked under its new name; the second under the name ASSEMBLY.

It is expedient, during system generation, to use the largest assembler the machine can support because the performance improvement is most significant.

VARIANTS OF PL/I

Two variants of the PL/I compiler can be built. One of the PL/I variants requires 10K bytes (of problem program storage), while the other requires 12K. The 12K variant allows the system input and output files to be assigned to a 2311 disk drive or a 2314 direct access storage facility, if the supervisor supports SYSFIL. PL/I is capable of using either disk or tape work files (as are COBOL, FORTRAN, Basic FORTRAN, and RPG). Thus, PL/I also furnishes compile-time device independence for work files.

PL/I AND SYSTEM INPUT/OUTPUT ON DISK

The two variants of the PL/I compiler differ in their treatment of SYSIPT, SYSLST, and SYSPCH. If one or more of these logical units is assigned to a 2311 during compilation, the variant of the PL/I compiler requiring 24K bytes of main storage (12K for the compiler itself), must be built.

The following statements will generate the 12K variant:

```
    INCLUDE IJXPLID
// EXEC    LNKEOT
```

If the 12K variant is not required, the following statements must be specified:

```
    INCIUDE IJXPLI
// EXEC    LNKEDT
```

If either SYSIPT or SYSIST is assigned to a 2311 or 2314 for execution of PL/I object programs, the I/O modules invoked to support these assignments must be retained. During system generation, a relocatable library maintenance run should be performed to rename these modules before deleting the PL/I compiler from the relocatable library. The following control statements delete the I/O modules that do not support the disk facility from the relocatable library (because they are no longer needed), rename the PL/I object time I/O modules that do support the disk facility, and delete the PL/I compiler from the relocatable library.

```
// EXEC MAINT
...
DELETR IJKSYSA,IJKSYSI
RENAMR IJXSYSA,IJKSYSA,IJXSYSI,IJKSYSI
DELETR IJX.ALL
...
```

The user may want to retain the card modules that do not support the disk facility (if there is a possibility that card or tape input only and printer or tape output only are desired at some future time). The following control statements permit punching these modules. The user must punch these modules before they are deleted from the relocatable library as shown in the preceding example.

```
// EXEC RSERV
    PUNCH IJKSYSA,IJKSYSI
/*
```

If neither SYSIPT nor SYSIST is assigned to a 2311 or 2314 during execution of PL/I object programs, only the DELETR IJX.ALL statement is required for the maintenance run.

During system generation, utilities and work-file variants that are not needed can be deleted. If the system volume received by the user is a disk pack, it is capable of operating as a system. If the system volume is a tape reel, it is self-loading tape that must be restored onto a disk pack before it is operable.

FORTRAN Compatibility

The FORTRAN library contains a module, ILFACOM, to provide compatibility with Basic FORTRAN subprograms. Because of differences in design objectives, object modules produced by the FORTRAN and Basic FORTRAN compilers are not compatible without this interface. With it, subprograms compiled under Basic FORTRAN can be incorporated into a FORTRAN program.

The compatibility module can be invoked on a job-by-job basis, or the system can be altered at system generation time so that it is brought in with all Basic FORTRAN linkage edits. The procedure for using it for a single job is discussed in the FORTRAN IV Programmer's Guide, listed in the Preface.

The system can be altered permanently by executing the jobstream book named Z.ILFMERGE which is in the source statement library of the DOS system residence volume supplied by IBM. This action deletes all Basic FORTRAN object time library routines from the relocatable library. It replaces them with references to the corresponding FORTRAN object time library routines and to ILFACOM. Subsequently, any Basic FORTRAN object module that refers to a library routine, such as the square root subprogram, IJTSSQT, actually uses the corresponding FORTRAN routine, in this case, ILFSSQRT.

This procedure is recommended only for installations that intend to convert entirely from Basic FORTRAN to FORTRAN, but do not want to recompile existing programs and subprograms. The action provides additional space in the relocatable library by eliminating the Basic FORTRAN routines, but it also increases the execution time of all Basic FORTRAN modules.

WARNING DIAGNOSTICS

The following warning diagnostics appear in the linkage editor maps during system generation, but they do not indicate errors.

Assembler

DWF variant (incorporated by including IJQD16DW for assembler linkage edit).

*UNREFERENCED SYMBOLS

EXTRN	IJQD0\$21
EXTRN	IJQD0\$24
EXTRN	IJQD0\$39
EXTRN	IJQD0\$60
EXTRN	IJQD2\$30
EXTRN	IJQRTA35
EXTRN	IJQRTA45
EXTRN	IJQRTB30
EXTRN	IJQRTB42
EXTRN	IJQRTB57

POSSIBLE INVALID ENTRY POINT DUPLICATION IN INPUT

TWF variant (incorporated by including IJQD16TW for the assembler linkage edit).

*UNREFERENCED SYMBOLS

EXTRN	IJQD0\$15
EXTRN	IJQD0\$18
EXTRN	IJQD0\$58
EXTRN	IJQD0A10
EXTRN	IJQD0\$60
EXTRN	IJQRTA35
EXTRN	IJQRTA45
EXTRN	IJQRTB30
EXTRN	IJQRTB42
EXTRN	IJQRTB57
EXTRN	IJQD2\$30
EXTRN	IJQD2\$60

POSSIBLE INVALID ENTRY POINT DUPLICATION IN INPUT

Variant utilizing additional main storage (incorporated by including IJQD32 for the assembler linkage edit).

*UNREFERENCED SYMBOLS

EXTRN IJQD0\$45
EXTRN IJQD0\$57
EXTRN IJQD0\$58
EXTRN IJQD0A10
EXTRN IJQRTA30
EXTRN IJQRTB39
EXTRN IJQRTB54
EXTRN IJQD2\$30
EXTRN IJQD2\$60

POSSIBLE INVALID ENTRY POINT DUPLICATION IN INPUT

System Generation and Maintenance Procedure

Many techniques exist for generating and maintaining operational volumes. Each installation uses techniques dependent on its machine configuration and its selection of system and application programs. The techniques described here correspond to the following principal machine configurations relevant to system generation and maintenance:

1. At least two 2311 disk drives.
2. One 2311 disk drive.
3. One 2314 direct access storage facility.

The three examples given (Figures 8, 10, and 12) do not show the coding necessary to linkage edit and delete all IBM-supplied components. They are meant only to be samples and must be tailored to meet each user's needs. Additional control statements required to meet the user's needs for linkage editing and deleting any IBM-supplied components are given in Appendix C.

If the system has a tape unit (7-track tapes must have the Data Conversion feature to be used during system generation and maintenance), the system is shipped from IBM on tape. The IBM-supplied tape is a self-loading tape that must be transferred from tape to a disk pack before starting system generation. The resulting disk pack is then ready for system generation. The IBM-supplied tape should be retained as an additional backup tape. If a system has no tapes, the 2311 resident system is shipped on a disk pack that is ready for system generation. The 2314 resident system is shipped on tape(s) only.

Each System Generation Job begins with a new IPL procedure, including the necessary ADD, SET, and ASSGN statements. Typically, each job consists of many job steps, including such librarian programs as:

- CSERV (core image library service) to punch out (or write on magnetic tape or disk) programs from the core image library during maintenance.
- SSERV (source statement library service) to punch out (or write on magnetic tape or disk) macro definitions.
- RSERV (relocatable library service) to punch out (or write on magnetic tape or disk) the relocatable modules used to build IBM-supplied processor programs.
- DSERV (directory service) to display on SYSLST the current contents of one or more library directories and their remaining library capacities.
- MAINT (library maintenance) to delete and/or catalog library elements, and also to condense and reallocate (2311) library extents.
- CORGZ (copy or merge and organize) to selectively copy or merge one disk pack onto another disk pack, with the option of allowing larger/smaller allocations for each library of the new pack.

The sequence of job steps depends on the configuration available and the operational packs each user is building. Certain activities are common to many users:

1. The general system generation procedure is:

- a. Initialize the disk pack to contain the system.
 - b. For disk and tape users, restore the IBM-supplied tape onto disk. For two disk drives and no tape drives, copy the IBM-supplied disk to another disk to obtain backup.
 - c. Retrieve sample problems.
 - d. Delete unwanted programs from the system (all libraries).
 - e. Allocate library sizes required.
 - f. Set standard labels for SYSLNK, SYS001, SYS002, and SYS003 if desired.
 - g. Assemble supervisor into cards.
 - h. Linkage edit and catalog supervisor and IBM components.
 - i. Assemble user IOCS modules.
 - j. Catalog IOCS modules to the relocatable library.
 - k. Delete supervisor and IOCS macros if not desired.
2. The supervisor generation macro instructions must be keypunched to form a single source deck.
 3. DELETETR cards are selected or prepared for each relocatable library component that the user does not need in his system.

On a system with at least two disk drives, the user can copy selectively rather than delete (DELETETR). To copy selectively, prepare the librarian cards in the form: COPYR IJx.ALL.

4. DELETS A.xxxxxxxx cards are selected or prepared for each macro definition that the user does not need in his system. The list of IBM-supplied macro definitions appears in Appendix C. The user may wish to retain certain low-usage macro definitions, such as supervisor generation macros, only on his system maintenance pack, rather than on his operational pack(s). The books, Z.DELETECL, Z.DELETERL, Z.DELETESI and Z.LINKEDIT, can be retrieved through SSERV. These books contain the necessary statements for the user to delete or linkage edit selectively any components from the system. A pause card is read immediately before a deletion or linkage-edit job is performed. This allows the user to enter EOB to perform the job or to type in CANCEL at the 1052 printer keyboard to bypass that deletion or linkage edit. If a user does not wish to go through the complete book performing selective jobs, he can choose only those cards he needs from the book.
5. After a component is linkage edited into the core image library of a single drive system, the user can free a large extent on any operational pack by deleting the modules from the relocatable library used to build the component. The delete book Z.DELETERL can be used to perform this step. However, the user must then rebuild the relocatable library of the pack prior to updating a component, by entering the appropriate modules either from cards, magnetic tape, or disk. On a system without magnetic tape this tradeoff must be carefully considered: disk tracks made available vs. speed and simplicity of component maintenance.
6. To use the COBOL, PL/I, and RPG languages, the user must ensure that a certain collection of IOCS modules are available in the relocatable library of each operational pack. These modules are preassembled and

supplied in the relocatable library. Certain of these IOCS modules are linkage edited into each COBOL, PL/I or RPG object program. These modules are generated using the following macro definitions supplied by IBM:

CDMOD	Card Reader/Punch
PRMOD	Printer
MTMOD	Magnetic Tape
SDMODxx	Sequential DASD. SDMOD consists of ten similar macro definitions: SDMODFI for sequential disk with fixed input, SDMODFO for sequential disk with fixed output, etc. A complete description of SDMODxx is contained in the <u>Supervisor and Input/Output Macros</u> publication.
ISMOD	Indexed Sequential DASD
DAMOD	Direct Access Method, DASD
DIMOD	Device Independent Module

Assembler-language users can assemble these IOCS functions directly into their application programs, or the IOCS modules can be assembled separately and cataloged into the system relocatable library. The assembler also supports PTMOD, ORMOD, and MRMOD. Separate assembly of IOCS modules requires no additional main storage or additional execution overhead in speed. Those modules, shipped pre-assembled for IBM components, can also be used by any other program, if applicable. A separate assembly is preferable for most users because:

- Program assembly and reassembly time is minimized.
- Many IOCS modules will already have been assembled for COBOL, PL/I and RPG programs.
- Use of preassembled IOCS modules facilitates program maintenance and standardization.
- The xxMOD macro definitions just cited require a substantial number of cylinders in the source statement library.

The corresponding generated modules ordinarily require fewer cylinders in the relocatable library. Thus, users may prefer to retain xxMOD macro definitions only on the system backup volume, cataloging a selection of generated modules onto each operational volume.

During each system generation and maintenance procedure, system libraries are periodically copied onto magnetic-tape reels, disks, or cards to provide backup in case of subsequent specification errors or machine errors. Users may omit these backup procedures, but the indicated maintenance procedures and any additional precautionary procedures desired by the user should be followed.

The following IBM System/360 Basic Programming Support Utility Programs may be required for system generation and should be ordered with the initial distribution volume, depending on the configuration of the system. Each BPS utility must be loaded from cards by a separate IPI procedure.

- Distribution Program 360P-UT-208
- Initialize Disk 360P-UT-206
- Copy Disk-to-Tape 360P-UT-061
 Restore Tape-to-Disk
- Copy Disk-to-Card 360P-UT-062
 Restore Card-to-Disk
 - Initialize Tape 360P-UT-057
 - Universal Character
 - Set 360P-UT-048
 - Initialize Data Cell 360P-UT-204

8. Users are encouraged to perform a DSERV or check a system directory printout to determine the contents and sizes of the system libraries during system generation. This procedure enables the user to determine that enough blocks remain for linkage edit and catalog procedures. A DSERV requires the following control statements:

```
// JOB DSERV
// EXEC DSERV
  DSPLY ALL
/*
/6
```

A printout of the system directory is provided automatically following a linkage edit with an OPTION CATAL specified or any // EXEC MAINT.

9. The initial system volume from IBM contains the volume serial number 111111.

If the IBM-supplied volume is a tape, the user must initialize the disk pack with his volume serial number before restoring the tape to the disk. The standard labels (DLBL and EXTENT statements) shown for the examples are adequate for system generation. However, the EXTENT statement must be adjusted to reflect the user's volume serial number.

To use the standard labels for configurations with two disks, SYSLNK, SYS001, SYS002, and SYS003 can be assigned to the second disk. The standard labels shown in the following discussions assume the VTOC to be on Cylinder 199 of the residence volume. Following system generation, standard label assignments should be set that will be adequate to support the user's installation requirements.

The following rules must be observed when extents are assigned to Autotest work files:

- The extents for IJSYS01, IJSYSAT, and IJSYSLN must always be unique.
- The extent for IJSYSAT and IJSYSLN must be on the same device but need not be contiguous.
- The extents for IJSYSAT may be the same as those for IJSYS02 or IJSYS03.
- When the job is to compile-and-execute, the extents for IJSYSLN must be different from those for IJSYS02 or IJSYS03.

10. Standard labels (OPTION STDLABEL) have been defined on the system distributed by IBM for SYSLNK and SYS001. Appendix G discusses the format of the supplied system volume.

A reply of delete to the following message will destroy the system residence file unless it is encountered during an allocate (ALLOC) run:

```
DOS SYSTEM RESIDENCE FILE
4444A OVERLAP ON UNEXPIRED FILE
```

The core image library allocations on the IBM-supplied volume(s) are not sufficient to contain all of the system components on a 2311. The adequacy of allocations can be determined through the use of Appendix G. Refer to Appendix C for core image phase names, relocatable module names, and source statement macro names. Phases, modules, and macros are identified by component.

Also included in Appendix C are those statements required to linkage edit and delete each component.

11. If the installation-tailored supervisor does not exceed the SEND address of the IBM-supplied supervisor, linkage editor, librarian, and assembler do not need to be linkage edited and cataloged again to the core image library.

IBM BPS Utility Programs

At the end of system generation, the user is advised to copy the system volume for operational volume backup. To restore the volumes to a disk pack, the IBM BPS copy and restore or the distribution program utility programs should be used. The user should be familiar with the BPS utility publications as listed on the front cover of this publication. The following control information must be inserted in the program deck to operate these programs:

Note: The channels used by the BPS supervisors are:

Multiplexor (channel 0)
Selector 1
Selector 2

Copy and Restore

- The following job control cards must be placed in the program deck before the first card containing a D in Column 73.

Copy Disk-to-Tape or Card Utility Programs

```
// JOB CDSK {CD}
// VOL SYSIPT, UIN
// DLAB (must describe the format one label for SYSRES in the
// SYSRES VTOC)
// XTENT
// CONFIG 001
// ASSIGN SYSIPT, X'cuu', dd
// ASSIGN SYSOPT, X'cuu', dd, X'ss'
// ASSIGN SYSRDR, X'cuu', dd, X'ss'
// ASSIGN SYSLST, X'cuu', dd
// ASSIGN SYSLOG, X'cuu', dd
// DATE 68110
// EXEC
```

Restore Card or Tape-to-Disk Utility Programs

```
// JOB R {CD} DSK
// CONFIG 001
// ASSIGN SYSIPT, X'cuu', dd, X'ss'
// ASSIGN SYSOPT, X'cuu', dd
// ASSIGN SYSLST, X'cuu', dd
// ASSIGN SYSRDR, X'cuu', dd
// ASSIGN SYSLOG, X'cuu', dd
// DATE 68110
// EXEC
```

Note: For the BPS description (dd) parameter see Appendix F.

- The following utility modifier card must be placed in the program deck before the first card containing an E in Column 73. This card is used only for the copy programs and must be omitted from the program deck for the restore program.

```
//bUCRlTF,A=(1600),N=(1),OL,IPL,LOG
```

The Copy Disk to Card and Restore Card to Disk programs have the ability to be restarted if required. Refer to the BPS DASD utility publication referenced on the front cover of this publication.

Note: In this control card b indicates one blank space.

The following operating procedures are required for running the IBM-supplied utility object programs:

1. Ready the necessary I/O units.
2. Set the console switches as follows:
 - a. ROS CONTROL, RATE, ADDRESS COMPARE, and CHECK CONTROL TO PROCESS.
 - b. The three Load-Unit switches to the address of the card reader used for loading the program.
3. Loading of the utility program.
 - a. Check the preceding units and settings; then press the System-Reset key.
 - b. Place the object deck with control cards in the reader hopper.
 - c. When the reader unit is ready, press the console Load key.

Distribution Program 360P-UT-208

The distribution program can be used to copy a DOS system to tape for backup. The resulting tape is a self loading tape that is similar to the IBM-supplied system tape. The only difference in the tapes is in the contents of the systems. The tape produced by this program has the following format:

- IPL
- Initialize disk program
- Tapemark
- IPL
- Restore program
- File identification record
- File label information
- Disk file (DOS system)
- Tapemark

When restored to a disk pack, this tape will not only restore the system as it was copied, but will also initialize the pack to which it is being copied. The instructions for restoring the system to a disk are the same instructions for restoring the IBM-supplied system to a disk pack before performing system generation.

COPYING A SYSTEM TAPE TO DISK

To copy a DOS system to tape:

- Mount the DOS system and a tape.
- The following job control cards must be placed in the program deck between the cards containing ID numbers C208 and D208 in columns 73-76:
- Place the deck in the card reader.

```
// JOB DISCPY
// DATE 68110
// ASSGN SYSLOG,X'cuu',dd
// ASSGN SYSIST,X'cuu',dd
// ASSGN SYS000,X'cuu',dd (disk)
// ASSGN SYS001,X'cuu',dd[,X'ss'](tape)
// CONFG 001 (optional, 16K assumed)
// EXEC
```

Note: For the BPS description parameter (dd) see Appendix F.

- The following utility modifier card must be placed immediately following the program deck:

```
//bUDSb'field one of format 1 DASD file label 44-characters' Col.53
```

- Dial on the console the address of the card reader.
- Check the units and settings; then press the System-Reset key.
- Press the console load key.
- When the Wait light comes on, press Start and EOF on the card reader.

RESTORING A SYSTEM TAPE TO DISK

The IBM-supplied system residence tape must be copied onto a disk pack before system generation can be performed. The pack that is to contain the system must be initialized with a volume label and a volume table of contents (VTOC). If the disk pack is not initialized or if the VTOC is not at cylinder 199, the pack must be initialized.

INITIALIZE DISK

The following instructions and control cards will allow the user to properly initialize his disk:

- Mount the distribution tape.
- Place the following control cards in the card reader, in the sequence shown:

Card Col. 1

Card 1 // JOB INTDSK

Card 2 // DATE yyddd yy = 00 to 99 decimal
ddd = 001 to 366 decimal

Card 3 // ASSGN SYSOPT,X'cuu',Dd
cuu = channel and unit of disk drive
Dd = D1 for 2311 or D3 for 2314

Card 4 // ASSGN SYSLOG,X'cuu',C1
cuu = channel unit 1052

Card 5 // EXEC

Card 6 // UIDbIR,C1

Card 7 // VTOC STRTADR=(0199000),EXTENT=(y)
y = number of tracks allotted
to VTOC in decimal (1-10).

Card 8 VOL1nnnnnn nnnnnn = Volume serial number
Columns 42-51 are reserved for user's
identification.

Card 9 // END

- Dial on the console the address of the tape unit containing the distribution tape into the CPU load address switches.
- Press Load.
- When the Wait light comes on, press Start and EOF on the card reader.
- The message EOJ will be printed on the 1052 printer-keyboard when initialization is complete. The system can then be copied on the disk.

BYPASS INITIALIZE DISK

If the disk has previously been properly initialized, the Initialize Disk procedure can be omitted and the following procedure performed to bypass the initialize disk routine:

- Mount and ready the distribution tape.
- Place the following control cards in the card reader in the sequence shown:

Card Col. 1

Card 1 // JOB INTDSK

Card 2 // DATE yyddd yy = 00 to 99 decimal
ddd = 001 to 366 decimal

Card 3 // ASSGN SYSLOG,X'cuu',C1

Card 4 // LOG

Card 5 // ASSGN SYSIPT,X'cuu',Tz[,X'90']
 cuu = channel and unit
 z = 2 for 9-track tape
 z = 1 for 7-track tape
 The X'90' entry is
 required if z = 1.

Card 6 // FILES SYSIPT,1

- Dial the address of the tape drive containing the distribution tape in the CPU load address switches.
- Press Load.
- When the Wait light comes on, ready the card reader containing the control cards by pressing Start and EOF.
- The tape will forward-space past the initialization program and the following message will appear on SYSLOG:

000C
 4 000A

RESTORE A SYSTEM TAPE TO DISK

Following initialization or bypassing initialization of the disk pack, the IBM-supplied system tape can be restored to disk by this procedure:

- Do not rewind the distribution tape.
- Clear the card reader.
- Place the following control cards in the card reader:

Card Col. 1

Card 1 // JOB DISRST

Card 2 // DATE yyddd yy = 00 to 99 decimal
 ddd = 001 to 366 decimal

Card 3 // ASSGN SYS000,X'cuu',Dd
 cuu = channel and unit of
 the initialized disk
 Dd = D1 for 2311 or D3 for 2314

Card 4 // ASSGN SYSLST,X'cuu',L1

Card 5 // ASSGN SYSLOG,X'cuu',C1

Card 6 // EXEC

- IPL from the distribution tape and press Load on the console.
- When the Wait light comes on, ready the card reader by pressing Start and EOF.
- The following message appears in SYSLOG:

4444A

Type in 4 **ⓑ**, and press INTERRUPT to continue.

- If the message END OF VOLUME ON SYSIPT 3777A occurs while restoring a multivolume file, ready the next reel on SYSIPT reply 22 and press interrupt to continue. This message will not be encountered if the second volume of a two-volume system distribution is mounted on an alternate drive assigned to SYS002.

// ASSGN SYS002,X'cuu',TZ

- When the job is finished, the following message is printed on the IBM 1052 Printer-Keyboard and the disk pack is ready for system generation:
DOS SYSTEM RESIDENCE FILE
nnnnnn RECORDS RESTORED FOR ABOVE FILE
3007
END OF JOB
3008

Macro Instructions for Generating a Supervisor

Using the IBM-supplied volume, each installation normally generates a more efficient supervisor using the supervisor generation macro instructions. The macro instructions describe the machine configuration, standard I/O assignments, and standard processing options.

This section defines the ten macro instructions and their parameters required to generate an installation-tailored supervisor for the Disk Operating System. Figure 4 is a consolidated list of the supervisor generation macros discussed.

RULES FOR USING SUPERVISOR GENERATION MACROS

1. The assumed value for an omitted parameter is underlined in the following discussion and in Figure 4. Figure 5 shows device type codes to be used for system generation.
2. Material enclosed in braces { } indicates a programmer option. One of the enclosed values must be selected by the programmer.
3. Bracketed operands are optional, e.g., [n].
4. Replace the letter n in a parameter with a decimal number.
5. The name field must be blank. The operation field always contains the mnemonic operation code. The operand field contains the parameters.
6. Several parameters may be included on one line for all macros. Separate each parameter with a comma. No embedded blanks are permitted. Continuation cards are permitted (nonblank character in column 72; the continue column is column 16).
7. In the expression X'cuu', replace cuu with the hexadecimal number for channel and unit.
8. The macros must be issued in the following sequence: SUPVR, CONFIG, STDJC, FOPT, PIOC, ALLOC, IOTAB, DVCGEN, ASSGN, SEND.
9. The DVCGEN, ASSGN, and ALLOC macros are not required. They are specified if input/output tables (DVCGEN) are being specified, if standard assignments (ASSGN) are being made or if storage is allocated (ALLOC) for MPS at system generation time.
10. An END card and a /* card must follow the SEND macro instruction.

SUPERVISOR

SUPVR This macro instruction and its parameters define the system as disk resident and its ability to perform multiprocessing, MICR or Teleprocessing.

Parameters for SUPVR

SYSTEM=DISK Always used with the SUPVR macro instruction.
SYSTEM=DISK is assumed if this parameter is omitted.

MPS= $\left\{ \begin{array}{c} \text{NO} \\ \text{YES} \\ \text{BJF} \end{array} \right\}$ Specify if there is to be multiprogramming support. When YES or BJF is specified the system generated is capable of supporting two foreground programs. YES or BJF must be specified if TP=QTAM. When BJF is specified, batched job environment will be supported for both foreground partitions. Multiple communication regions are generated only if BJF is specified. MPS=YES is implied if MPS=BJF is supplied.

TP= $\left\{ \begin{array}{c} \text{NO} \\ \text{BTAM} \\ \text{QTAMn} \end{array} \right\}$ Specify if Teleprocessing support is desired and if so, whether Basic or Queued Access Method (BTAM or QTAM) is desired. When QTAM is specified, SVC support for BTAM is also included. n is the maximum number of QTAM message processing programs in the system at one time. n may have any value from 2 to 12.

MICR= $\left\{ \begin{array}{c} \text{NO} \\ 1412 \\ 1419 \\ 1419D \end{array} \right\}$ Specify if the supervisor is to support magnetic ink character readers. If both 1412's and 1419's are present, indicate 1419. If 1259's are to be supported, also indicate 1419. 1419D indicates Dual Address Adapter 1419's. If 1412/1419's are attached to the multiplexor channel, the PIOC'S parameter BMPX=YES is not supported. 1419 support gives 1259 capability.

AP= $\left\{ \begin{array}{c} \text{NO} \\ \text{YES} \end{array} \right\}$ Specify if there is to be multitasking support. Multitasking allows the execution of more than one program within a partition. MPS=YES and WAITM=YES are assumed if AP=YES.

EU= $\left\{ \begin{array}{c} \text{NO} \\ \text{YES} \end{array} \right\}$ Specify if the IBM 1401/1440/1460 Emulator program is to be executed. The MODEL operand in the CONFIG macro can be MODEL=25, or MODEL=30 for IBM Model 2025, and it must be MODEL=30 and MODEL=40 for IBM Models 2030 and 2040, respectively.

CONFIGURATION

CONFIG This macro instruction and its parameters define the system configuration and can be used to specify generation of optional supervisor services. If the assumed options are all satisfactory, the only entry required is the CONFIG macro itself without any parameters.

Parameters for CONFIG

MODEL={30/nn} Specify the model number of the system (nn=30, 40, etc). If MICR support is required on a Model 65, MODEL=65 should be indicated for maximum performance. If 1401/1440/1460 emulator program support is desired for the:

- IBM Model 2025, specify MODEL=25 or MODEL=30.
- IBM Model 2030, specify MODEL=30.
- IBM Model 2040, specify MODEL=40.

SP={NO/YES} Specify if the storage protection feature is available to the system. YES is assumed if the MPS=YES or MPS=BJF parameter is specified in the SUPVR macro.

DEC={NO/YES} Specify if the decimal feature is present.

FP={NO/YES} Specify only if the floating point feature is present.

TIMER={NO/YES} Specify if the timer feature is present. If YES is specified, GETIME support is provided.

JOB CONTROL OPTIONS

STDJC This macro instruction and its parameters specify the standard settings for job control. If the assumed options are all satisfactory, the only entry required is the STDJC macro instruction itself, without any parameters. These standard options can be locally overridden by an OPTION statement.

Parameters for STDJC

DECK={YES/NO} Specify if language translators are to output object modules on SYSPCH.

LIST={YES/NO} Specify if language translators are to write source module listings and diagnostics on SYSLST.

LISTX={NO/YES} Specify if compilers are to write hexadecimal object module listings on SYSLST.

SYM={NO/YES} Specify if assembler is to output symbol tables on SYSPCH. SYM=YES must be specified if the PL/I compiler is to produce a symbol and offset table listing.

XREF={YES/NO} Specify if assembler is to write symbolic cross-reference lists on SYSLST.

ERRS= $\left\{ \begin{array}{l} \text{YES} \\ \text{NO} \end{array} \right\}$ Specify if compilers are to summarize all errors in source programs on SYSLST. Assembler and PL/I always assume ERRS=YES.

CHARSET= $\left\{ \begin{array}{l} 48C \\ 60C \end{array} \right\}$ Specify either the 48- or 60-character set for PL/I translator input on SYSIPT.

LOG= $\left\{ \begin{array}{l} \text{YES} \\ \text{NO} \end{array} \right\}$ Specify for a listing of all control statements on SYSLST. LOG=NO suppresses the listing of all job control statements on SYSLST.

DUMP= $\left\{ \begin{array}{l} \text{YES} \\ \text{NO} \end{array} \right\}$ Specify if a dump of the registers and main storage is to be written on SYSLST in the event of an abnormal program end, cancel, or program check.

LINES= $\left\{ \begin{array}{l} 56 \\ nn \end{array} \right\}$ Specify the number of lines per page on SYSLST. The minimum is 30; the maximum is 99.

DATE= $\left\{ \begin{array}{l} \text{MDY} \\ \text{DMY} \end{array} \right\}$ Specify the format of the date MDY=month/day/year. DMY=day/month/year.

OPTIONAL FEATURES IN THE SUPERVISOR

FOPT This macro and its parameters specify additional optional features that can be included in the supervisor.

Parameters for FOPT

OC= $\left\{ \begin{array}{l} \text{NO} \\ \text{YES} \end{array} \right\}$ Specify if external interruptions (except timer) can be handled by problem programs. If YES is specified, the facility is available to all programs in MPS. The Tape Compare Utility program requires OC=YES. YES is required if emulator program operator services are to be requested through the INTERRUPT key.

IT= $\left\{ \begin{array}{l} \text{NO} \\ \text{BG} \\ \text{F1} \\ \text{F2} \end{array} \right\}$ Specify if the interval timer can be handled by problem programs. When interval timer facilities are available (i.e., IT=BG, F1 or F2) TIMER=YES is assumed for the CONFIG macro. Timer support is available to only one program in MPS. QTAM requires F1.

PC= $\left\{ \begin{array}{l} \text{NO} \\ \text{YES} \end{array} \right\}$ Specify if a user program check routine will be used. Included in supplied supervisor because QTAM, FORTRAN, Basic FORTRAN, COBOL, PL/I, RPG, and Autotest require PC=YES.

TEB= $\left\{ \begin{array}{l} \text{NO} \\ n \end{array} \right\}$ Specify if tape error statistics are to be accumulated and logged where n is the number of tape drives and/or tape cartridge readers attached to the

system. Allow extra TEBs for possible future expansion of the system. The maximum number is 254.

SKSEP= $\left\{ \begin{array}{l} \text{NO} \\ \text{YES} \\ n \end{array} \right\}$ Specify if SEEKS are to be separated from the remainder of channel programs. Seek separation allows other devices on the channel to be accessed (including other seeks) during the seek. YES indicates support for all DASD type devices specified by the DVCGEN macro at system generation time. n is the number of DASD devices to be supported and cannot be less than the number of DASD devices specified at system generation. The maximum is 254.

CE= $\left\{ \begin{array}{l} \text{NO} \\ \text{YES} \\ n \end{array} \right\}$ Specify the number of bytes to be allocated to the customer engineer serviceability routines. The minimum number of bytes that can be specified for n is 600. For the actual number of bytes allocated see Appendix G.

PTO= $\left\{ \begin{array}{l} \text{NO} \\ \text{YES} \end{array} \right\}$ Specify if the Physical Transient Overlap (PTO) feature is to allow the system to select tasks while Fetch is reading a fetched (or loaded) phase from the system residence file, or while I/O operations are being performed during Error Recovery Procedures (ERP). This overlap allows increased throughput. MPS=YES or BJT must be specified.

CBF= $\left\{ \begin{array}{l} \text{NO} \\ n \end{array} \right\}$ Specify I/O requests are to be buffered under the following conditions:

1. The actual record to be written does not exceed 80 characters.
2. Data or command chaining is not performed.
3. The CCB associated with this operation does not indicate the acceptance of unrecoverable I/O errors, posting at device end, or user error routines.
4. The CCB does not request sense information.

Console buffering allows overlap of CPU processing with write operations to SYSLOG by satisfying the requestor's WAIT immediately, rather than at I/O completion time. When this option is selected, the number of CHANQ entries should exceed the number of CBF entries so that the buffering process is not bound by the number of CHANQ entries. If the assumed option is taken for CHANQ and CBF is selected, the number of CHANQ entries will be assumed to be six more than the CBF entry. Numbers 1 through 9 are valid, and one is assumed if the operand is invalid.

CCHAIN= $\left\{ \begin{array}{l} \text{NO} \\ \text{YES} \end{array} \right\}$ Specify if command chaining support for retry on I/O operations is to be handled. When command chaining and an error occurs, CCHAIN allows the user to retry at the last CCW executed. Normal retry would return to the first CCW in the channel program. To make use

of this option the user must have the appropriate bit set in the CCB. CCHAIN=YES must be specified if data or command chaining of IBM 2495 Tape Cartridge Reader input is performed.

TRKHLD=n Specify if the track hold function is to be supported. When processing sequential disk workfiles or updates to direct access files, specify if a hold is to be placed on the track of the record being read. The hold prevents anyone else that is using track hold from accessing that track. The maximum number of tracks that can be held at one time is 255. The default is 10 if n is an invalid parameter (nonnumeric or outside the range 1-255). MPS=YES or BJJ must be specified if TRKHLD=n.

AB= $\left\{ \begin{array}{l} \text{NO} \\ \text{YES} \end{array} \right\}$ Specify if the abnormal termination exit function is to be supported. The abnormal termination exit allows the user to exit to a user's routine before an abnormal end of job causes a program to be cancelled.

WAITM= $\left\{ \begin{array}{l} \text{NO} \\ \text{YES} \end{array} \right\}$ Specify if the multiple wait function is to be supported. This function allows the user to use the WAITM macro to wait for one of a number of events to occur. WAITM=YES is assumed if AP=YES.

*DASDFP= $\left\{ \begin{array}{l} \text{NO} \\ (n, n, \left\{ \begin{array}{l} 2311 \\ 2314 \\ 2321 \end{array} \right\}) \end{array} \right\}$

Specify if supervisory DASD file protection is handled where n,n indicates the range of channels to which DASDs may be attached. Either 2311 or 2314 indicates file protection for both and 2321 indicates file protection for 2311, 2314, and 2321. If 2311, 2314, or 2321 are omitted, both 2311 and 2314 are assumed. DASDFP prevents the user from writing outside the extents of his file in case of program error. Extents are protected to the nearest cylinder except for 2321, where they are protected to the nearest head bank. This feature does not protect the file from being overwritten.

*SYSFIL= $\left\{ \begin{array}{l} \text{NO} \\ (\left\{ \begin{array}{l} 2311 \\ 2314 \end{array} \right\} [n_1, n_2]) \end{array} \right\}$

Specify if system input and system output (SYSRDR, SYSIPT, SYSLST, SYSPCH) files may be assigned to a 2311 or 2314. Specification of either gives support for both. If MPS=BFJ in the SUPVR macro, this parameter supports foreground logical units when running in batched mode. If the emulator program parameter SYSIO=222 or SYSIO=333 is indicated, a value must be specified for SYSFIL.

n₁ = residual capacity for beginning of operator notification when SYSLST assigned to disk.
100 ≤ n₁ ≤ 65535. If n₁ is omitted, 1000 is assumed.

n₂ = residual capacity for beginning of operator notification when SYSPCH assigned to disk.

100 ≤ n₂ ≤ 65535. If n₂ is omitted, 1000 is assumed.

*Valid when 24K bytes of main storage are available. (See PL/I variant for the conditions governing logical units assigned to a disk.)

Note: Information on the macro instructions STXIT, EXIT, and SETIME is contained in the Supervisor and Input/Output Macros publication.

PHYSICAL IOCS

PIOCS This macro instruction and its parameters define the configuration requirements to be supported by physical IOCS. If the assumed options are all satisfactory, the only entry required is the PIOCS macro itself, without any parameters.

Parameters for PIOCS

SELCH = $\left\{ \begin{array}{l} \text{YES} \\ \text{NO} \end{array} \right\}$ Specify if selector channels are attached to the system.

BMPX = $\left\{ \begin{array}{l} \text{NO} \\ \text{YES} \end{array} \right\}$ Specify if burst mode devices will be supported on multiplexor channel. If YES is specified, unbuffered devices will not multiplex. If 1412/1419s are attached to multiplexor channel, BMPX=YES is not supported.

CHANSW = $\left\{ \begin{array}{l} \text{NO} \\ \text{RWTAU} \\ \text{TSWTCH} \end{array} \right\}$ Specify if channel switching tape control unit, RWTAU = 2404 or 2804, TSWTCH = 2816. If either 2403 or 2803 and 2816 is specified, RWTAU must be specified. If a 2804 is specified, RWTAU must be specified. If a 2816 is specified, TSWTCH must be specified.

TAPE = $\left\{ \begin{array}{l} \text{NO} \\ 9 \\ 7 \end{array} \right\}$ Indicates required tape PIOCS support.

9 = nine track only.

7 = seven or nine track.

NO = No tape drives attached. This is the assumed value.

ALLOCATE

ALLOC F1=nK, F2=nK Specifies storage partitioning MPS, where n must be a multiple of 2. This macro is optional. Most IBM components require 10K bytes of background area. Foreground area must be a minimum of 10K to allow BJT processing.

INPUT/OUTPUT TABLES

IOTAB This macro instruction and its parameters define the area for the necessary device tables for the system. If the assumed options are all satisfactory the only entry required is the IOTAB macro itself without any parameters.

Parameters for IOTAB

BGPGR= $\left\{ \begin{array}{c} \underline{10} \\ n \end{array} \right\}$ Specify the number of logical unit blocks (LUBs) for programmer units, i.e., the number of symbolic programmer logical units (SYS000-SYSnnn). The minimum value generated is 10. The maximum value generated is 222.

F1PGR= $\left\{ \begin{array}{c} \underline{5} \\ n \end{array} \right\}$ Specify the number of symbolic units of the class SYSnnn for F1. Valid only for MPS. Otherwise zero is assumed. The maximum value is 222.

F2PGR= $\left\{ \begin{array}{c} \underline{5} \\ n \end{array} \right\}$ Specify the number of symbolic units of the class SYSnnn for F2. Valid only for MPS. Otherwise zero is assumed. The maximum value is 222.

JIB= $\left\{ \begin{array}{c} \underline{5} \\ n \end{array} \right\}$ Specify the number of job information blocks for the system (JIBs). One is required for each logical unit temporarily reassigned by a // ASSGN statement that differs from standard system assignment (i.e., established by the operator at IPL time). One JIB is required for each alternate logical unit assignment. One JIB is required for each open 2311 extent with the DASD file protect feature except for system input/output extents. Two JIBs are required for each open 2321 extent with the DASD file protect feature. The minimum value generated is 5. The maximum value generated is 255.

CHANQ= $\left\{ \frac{6 \text{ or } 6+\text{CBF}}{n} \right\}$

Specify the number of entries in the channel queue. The minimum value generated is 6. If the assumed option is to be taken and CBF is to be specified, the assumed option will be six more than the CBF entry. The number of the channel queue should exceed the total number of I/O requests the user wishes to accumulate simultaneously. The start I/O commands for all channels are stored in this queue. The maximum value is 255.

IODEV= $\left\{ \frac{10}{n} \right\}$

Specify the number of I/O devices attached to the system. The maximum is 255. The minimum value is 5.

Note: The sum of BGPGR + F1PGR + F2PGR LUB's must not exceed 222.

INPUT/OUTPUT UNITS

DVCGEN This macro instruction and its parameters define the physical input and output units attached to the system. This macro instruction is optional.

Parameters for DVCGEN

CHUN=X'cuu' Specify the hexadecimal number of the channel and unit for the device.

DVCTYP=xxxxxx Specify the device type. Figure 2 contains the codes for each IBM-supported device.

CHANSW= $\left\{ \frac{\text{NO}}{\text{YES}} \right\}$ Specify if the device is attached to more than one selector channel. Indicates if the device can be switched (IBM 2816, 2804 or 2404 available).

- MODE=X'ss'
1. 2400T9. MODE is used to specify the tape mode. X'C0' is the default value.
 2. 2400T7. MODE is used to specify the tape mode. X'90' is the default value.
 3. 2702. MODE designates the SADxxx command. X'00' is the default value.
 - X'00' SAD0
 - X'01' SAD1
 - X'02' SAD2
 - X'03' SAD3
 See Appendix A for other values of ss.
 4. 2260 (Local). MODE is used to specify the 1053 printer when CHUN=X'cuu' refers to a 1053 attached to a 2848. The operand must be entered as MODE=X'01'.
 5. 1412/1419/1259. MODE designates the external interrupt bit associated with magnetic ink character readers. The mode X'01' through X'20' correspond to external interrupt PSW bits 31 through 26 respectively. For the dual address adapter 1419, this parameter is needed for both 1419P and 1419S.
 - X'01' Device attached to external line 7.
 - X'02' Device attached to external line 6.
 - X'04' Device attached to external line 5.
 - X'08' Device attached to external line 4.
 - X'10' Device attached to external line 3.
 - X'20' Device attached to external line 2.

Rules for Using DVCGEN

1. A separate DVCGEN macro instruction is required for each device. For a 2314, each individual unit needs a DVCGEN card.
2. The total number must not exceed the total number of devices specified in the IODEV parameter of the IOTAB macro.
3. DVCGEN macros must be specified in ascending channel address sequence.
4. Switchable units (attached to more than one selector channel) must be defined once on the lowest channel by which they are addressable.
5. The sequence of the DVCGEN cards determines the priority of the devices on their channel. SYSRES should be the first DVCGEN card if it is to have the highest priority. Switchable units must be the last devices specified for each channel, and must be on consecutive channels.
6. The specifications of these macros can be altered at IPL by ADD and DEL statements.
7. IBM 1052 Printer-Keyboards that are not on-line but were defined by DVCGEN statements must be deleted by DEL statements when performing IPL from the card reader.

ASSIGNING SYMBOLIC DEVICE NAMES TO ACTUAL I/O DEVICES

ASSGN This macro instruction and its parameters assign symbolic device names (LUBs) to physical I/O devices (PUBs). A separate macro instruction is required for each symbolic device name with a standard system generation assignment. This macro instruction is optional.

Parameters for ASSGN

SYSnnn,X'cuu' Symbolic-name will be any of the system background logical units (SYSIPT, SYSLOG, etc) or programmer logical units (SYS000, SYS001, etc). X'cuu' is the hexadecimal number of the channel and unit to which the symbolic device is attached. A separate macro is required for each standard assignment desired. Programmer assignments are made only for background jobs.

System input/output units (SYSRDR, SYSIPT, SYSLST, or SYSPCH) that are assigned to a tape or DASD when the system is generated will be unassigned by IPL. An unassigned device can cause a job to be canceled.

END OF SUPERVISOR MACRO INSTRUCTIONS

SEND (n) This macro instruction indicates the end of the supervisor. n is a multiple of 8 and cannot be greater than 32,760.

Figure 2 illustrates protected and unprotected supervisor storage generated by various combinations of supervisor options that affect storage protection.

The supervisor consists of two parts:

- the nucleus that extends from the address SYSS00 to NUCEND, and
- the combined transient area, CE Serviceability Programs (CE=YES), and save area that extends from the address YSEND to PPBEG (Figure 2A).

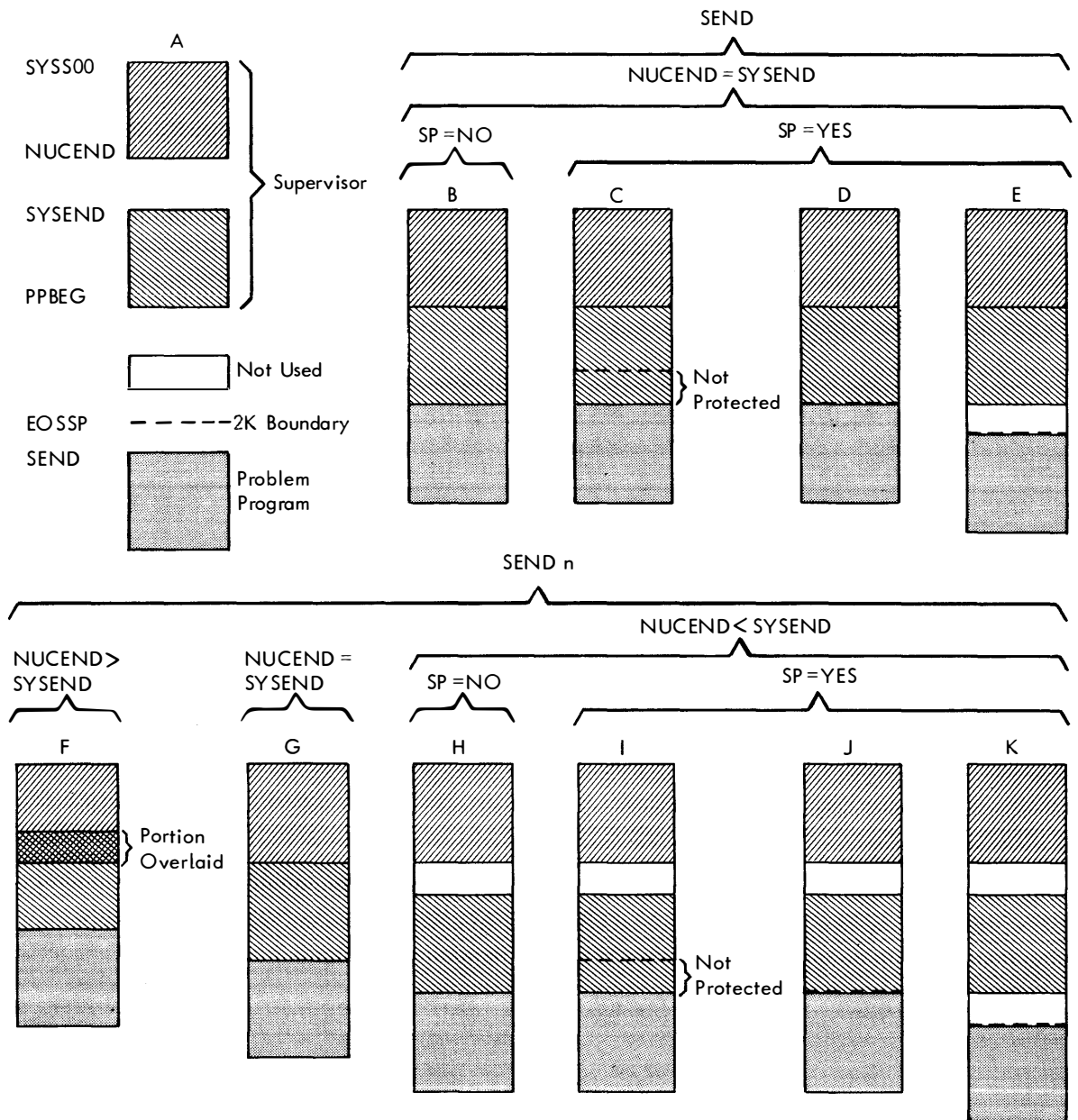

Figure 2. Unprotected Supervisor Storage Generated

SEND, SP=NO (Figure 2B)

If the operand n is not specified (Figure 2B), the address of NUCEND equals the address of SYSEND. Programs that are linkage edited to the end of the supervisor begin at PPBEG (Figure 2B). No space is provided for supervisor expansion, and growth in the supervisor will necessitate re-linkage editing user programs at the end of the supervisor.

SENDn,NUCEND>SYSEND (Figure 2F)/

SENDn,NUCEND=SYSEND (Figure 2G)/

SENDn,NUCEND<SYSEND,SP=NO (Figure 2H)

If the operand n is specified (Figure 2F-2H), the address of NUCEND can be greater than, equal to, or less than the address of SYSEND.

1. If NUCEND is greater than SYSEND (Figure 2F), a portion of the transient area overlays the supervisor nucleus. n must be increased, and the supervisor reassembled.
2. If NUCEND is equal to SYSEND (Figure 2G), the result is identical to the case where n was not specified (see Figure 2B) and the effect is also the same.
3. If NUCEND is less than SYSEND (Figure 2H), the area between SYSEND and NUCEND is not used and is available for future expansion of the supervisor. The difference between SYSEND and NUCEND is the number of bytes the supervisor may expand without having to re-linkage edit programs at the end of the supervisor.

SEND,SP=YES (Figures 2C, 2D, and 2E)

SENDn,NUCEND<SYSEND,SP=YES (Figures 2I, 2J, and 2K)

If Storage-Protect (SP=YES) is specified, the End-Of-Supervisor Storage-Protect (EOSSP) address is the first storage protect boundary after the SYSEND address when MPS=NO. When MPS=YES or BJT, the end of the supervisor will be the first storage protect boundary after the PTA address. The EOSSP address may be less than, equal to, or greater than the PPBEG address (end of supervisor).

1. If the EOSSP address is less than the PPBEG address, the area between these two addresses is not storage-protected. This will happen if the combination of MPS=NO and CE=YES was chosen (Figure 2I), and may happen if the:
 - a. SEND address is not specified (Figure 2C).
 - b. SEND address specified is not a multiple of 2048 bytes (Figure 2I).
2. If the EOSSP address is equal to the PPBEG address, the entire supervisor is storage-protected. This happens if the:
 - a. SEND address is not specified and the PPBEG address is a multiple of 2048 bytes (Figure 2D), or
 - b. SEND address specified is a multiple of 2048 bytes (Figure 2J).

3. If the EOSSP address is greater than the PPBEG address, the entire supervisor is storage-protected. The area between the PPBEG address and the EOSSP address is not used and is available for future expansion of the supervisor. The difference between the EOSSP address and the PPBEG address is the number of bytes the supervisor may expand without having to re-linkage edit programs at the end of the supervisor. This expansion area is in addition to any area between SYSEND and NUCEND. This may happen if the:

- a. SEND address is not specified (Figure 2E), or
- b. SEND address specified is not a multiple of 2048 bytes (Figure 2K).

MAXIMUM UNPROTECTED STORAGE

If SP=YES and a portion of the supervisor is not storage-protected (Figure 2C and 2I), the user should verify that the unprotected area falls within the following limits.

Figure 3 shows the maximum number of bytes in the area between the EOSSP address and the PPBEG address that may be unprotected.

	CE=NO	CE=YES	CE=n
MPS=NO PTO=NO FP=NO/YES	1832	2480	1880+n
MPS=YES/BJF PTO=NO FP= YES	664	1312	712+n
MPS=YES/BJF PTO=NO FP=NO	632	1280	680+n
MPS=YES/BJF PTO=YES FP=YES	120	760	160+n
MPS=YES/BJF PTO=YES FP=NO	88	728	128+n
MPS=NO PTO=YES FP=NO/YES	88	728	128+n

Figure 3. Maximum Unprotected Area between EOSSP and PPBEG (End of Supervisor) Address

Operation	Operand	Explanation
SUPVR		Supervisor macro instruction.
	SYSTEM=DISK	Specify a disk-resident supervisor. SYSTEM=DISK is assumed if this parameter is omitted.
	MPS= $\left\{ \begin{array}{l} \text{NO} \\ \text{YES} \\ \text{BJF} \end{array} \right\}$	Specify if there is to be multiprogramming support. When YES or BJF is specified the system generated is capable of supporting two foreground programs. YES or BJF must be specified if TP=QTAM. BJF must be specified if batched job environment is desired for foreground partitions.
	TP= $\left\{ \begin{array}{l} \text{NO} \\ \text{BTAM} \\ \text{QTAMn} \end{array} \right\}$	Specify if teleprocessing support is desired and if so, whether Basic or Queued Access Method (BTAM or QTAM) is desired. When QTAM is specified, SVC support for BTAM is also included. n is the maximum number of QTAM message processing programs in the system at one time. n may be any value 2 to 12.
	MICR= $\left\{ \begin{array}{l} \text{NO} \\ 1412 \\ 1419 \\ 1419D \end{array} \right\}$	Indicates whether the supervisor is to support magnetic ink character readers. If 1412/1419's are attached to the multiplexor channel, the PIOC parameter BMPX=YES is not supported.
	AP= $\left\{ \begin{array}{l} \text{NO} \\ \text{YES} \end{array} \right\}$	Specify if there is to be multiprogramming within a partition (multitasking) support. Multiprogramming within a partition provides the ability to execute more than one program (multitasking) within a partition. MPS=YES and WAITM=YES are assumed if AP=YES.
	EU= $\left\{ \begin{array}{l} \text{NO} \\ \text{YES} \end{array} \right\}$	Specify if the IBM 1401/1440/1460 Emulator program is to be executed. The MODEL operand in the CONFIG macro can be MODEL=25, 30, or 40.
CONFIG		Describes the hardware features.
	MODEL= $\left\{ \begin{array}{l} 30 \\ nn \end{array} \right\}$	Specify the model number.
	SP= $\left\{ \begin{array}{l} \text{NO} \\ \text{YES} \end{array} \right\}$	Storage protection feature. YES must be specified for MPS or BJF.
	DEC= $\left\{ \begin{array}{l} \text{NO} \\ \text{YES} \end{array} \right\}$	Decimal feature.
	FP= $\left\{ \begin{array}{l} \text{NO} \\ \text{YES} \end{array} \right\}$	Floating point feature.
	TIMER= $\left\{ \begin{array}{l} \text{NO} \\ \text{YES} \end{array} \right\}$	Timer feature.
STDJC		Specify standard settings for job control
	DECK= $\left\{ \begin{array}{l} \text{YES} \\ \text{NO} \end{array} \right\}$	Output of object modules of language translators on SYSPCH.
	LIST= $\left\{ \begin{array}{l} \text{YES} \\ \text{NO} \end{array} \right\}$	Source module listings and diagnostics from language translators on SYSLST.
	LISTX= $\left\{ \begin{array}{l} \text{NO} \\ \text{YES} \end{array} \right\}$	Hexadecimal object module listings from PL/I and COBOL on SYSLST.
	SYM= $\left\{ \begin{array}{l} \text{NO} \\ \text{YES} \end{array} \right\}$	Assembler and PL/I outputs symbol tables on SYSPCH: COBOL compiler outputs DATA DIVISION map on SYSLST.
	XREF= $\left\{ \begin{array}{l} \text{YES} \\ \text{NO} \end{array} \right\}$	Assembler outputs symbolic cross reference lists on SYSLST.
	ERRS= $\left\{ \begin{array}{l} \text{YES} \\ \text{NO} \end{array} \right\}$	COBOL, PL/I, FORTRAN, and Basic FORTRAN summarize all errors in source programs on SYSLST.
	CHARSET= $\left\{ \begin{array}{l} 48C \\ 60C \end{array} \right\}$	Specify the 48- or 60-character set for PL/I input on SYSIPT.

Figure 4. Macro Instructions for Supervisor Generation (Part 1 of 4)

Operation	Operand	Explanation
	LOG = $\left\{ \begin{array}{l} \text{YES} \\ \text{NO} \end{array} \right\}$	Listing of all control statements on SYSLST.
	DUMP = $\left\{ \begin{array}{l} \text{YES} \\ \text{NO} \end{array} \right\}$	Dump of registers and main storage on SYSLST.
	LINES = $\left\{ \begin{array}{l} 56 \\ nn \end{array} \right\}$	Number of lines per page on SYSLST.
	DATE = $\left\{ \begin{array}{l} \text{MDY} \\ \text{DMY} \end{array} \right\}$	Format of the date.
FOPT		Specify optional support in the supervisor.
	OC = $\left\{ \begin{array}{l} \text{NO} \\ \text{YES} \end{array} \right\}$	STXIT option is available for external interrupt (except timer). YES is required for tape compare utility program.
	IT = $\left\{ \begin{array}{l} \text{NO} \\ \text{BG} \\ \text{F1} \\ \text{F2} \end{array} \right\}$	STXIT option is available for interval timer interruption in the area specified. TIMER=YES is assumed.
	PC = $\left\{ \begin{array}{l} \text{NO} \\ \text{YES} \end{array} \right\}$	STXIT option is available for program check interruption. Included in supplied supervisor because FORTRAN, COBOL, RPG, QTAM, PL/I and Autotest require PC=YES.
	TEB = $\left\{ \begin{array}{l} \text{NO} \\ n \end{array} \right\}$	Specify if tape error statistics are to be accumulated and logged where n is the number of tape drives attached to the system. Allow extra TEBs for possible future expansion of system.
	SKSEP = $\left\{ \begin{array}{l} \text{NO} \\ \text{YES} \\ n \end{array} \right\}$	Specify if SEEK's are to be separated from the remainder of channel programs. Seek separation allows other devices on the channel to be accessed (including other seeks) during the seek. YES indicates support for all DASD type devices specified by the DVCGEN macro at system generation time. n is the number of DASD devices to be supported and cannot be less than the number of DASD devices specified at system generation. The maximum number is 254.
	CE = $\left\{ \begin{array}{l} \text{NO} \\ \text{YES} \\ n \end{array} \right\}$	Specify the number of bytes to be allocated to the customer engineer serviceability programs. 600 is the minimum number of bytes that can be specified. For the actual number of bytes allocated, see Appendix G.
	PTO = $\left\{ \begin{array}{l} \text{NO} \\ \text{YES} \end{array} \right\}$	Specify if the physical transient overlap feature is to allow the system to select tasks while Fetch is reading a fetched (or loaded) phase from the system residence file, or while I/O operations are performed during error recovery procedures.
	CBF = $\left\{ \begin{array}{l} \text{NO} \\ n \end{array} \right\}$	Specify if I/O requests are to be appraised for console buffering and indicate the number of buffers (1-9) to be generated.
	CCHAIN = $\left\{ \begin{array}{l} \text{NO} \\ \text{YES} \end{array} \right\}$	Specify if command chaining support for retry on I/O operations is to be handled.
	TRKHL = $\left\{ \begin{array}{l} \text{NO} \\ n \end{array} \right\}$	When processing sequential disk workfiles or updates of direct access files, specify if a hold is to be placed on the track of the record being read. The hold prevents anyone else who is using track hold from accessing that track. The maximum number of tracks that can be held at one time is 255 and the assumed value is 10.
	AB = $\left\{ \begin{array}{l} \text{NO} \\ \text{YES} \end{array} \right\}$	Specify if the abnormal termination exit function is to be supported. The abnormal termination exit allows the user to exit to a user's routine before an abnormal end of job causes a program to be cancelled.
	WAITM = $\left\{ \begin{array}{l} \text{NO} \\ \text{YES} \end{array} \right\}$	Specify if the multiple wait function is to be supported. This function allows the user to use the WAITM macro to wait for one of a number of events to occur.
	*DASDFP = $\left\{ \begin{array}{l} \text{NO} \\ (n, n, \left\{ \begin{array}{l} 2311 \\ 2314 \\ 2321 \end{array} \right\}) \end{array} \right\}$	Specify if supervisory DASD file protection is handled where n,n indicates the range of channels to which DASDs may be attached. Either 2311 or 2314 indicates file protection for 2311 and 2314. 2321 indicates file protection for 2311, 2314 and 2321.
	*SYSFIL = $\left\{ \begin{array}{l} \text{NO} \\ \left\{ \begin{array}{l} 2311 \\ 2314 \end{array} \right\} [n_1, n_2] \end{array} \right\}$	Specify if system input and system output (SYRDR, SYSIPT, SYSLST, SYSPCH) files may be assigned to a 2311 or 2314. Specification for either gives support for both. n ₁ = residual capacity for beginning of operator notification when SYSLST assigned to 2311/2314. 100 ≤ n ₁ ≤ 65535. If n ₁ is omitted, 1000 is assumed. n ₂ = residual capacity for beginning of operation notification when SYSPCH assigned to 2311. 100 ≤ n ₂ ≤ 65535. If n ₂ is omitted, 1000 is assumed.
	*Valid when 24K bytes of main storage are available.	

Figure 4. Macro Instructions for Supervisor Generation (Part 2 of 4)

Operation	Operand	Explanation
PIOCS		Define options and configuration requirements to be included in physical IOCS.
	SELCH= $\left\{ \begin{array}{l} \text{YES} \\ \text{NO} \end{array} \right\}$	Specify if selector channels are attached to the system
	BMPX= $\left\{ \begin{array}{l} \text{NO} \\ \text{YES} \end{array} \right\}$	Specify if burst mode devices on multiplexor channel is supported. If 1412/1419's are attached to the multiplexor channel BMPX=YES is not supported.
	CHANSW= $\left\{ \begin{array}{l} \text{NO} \\ \text{RWTAU} \\ \text{TSWTCH} \end{array} \right\}$	Specify if channel switching.
	TAPE= $\left\{ \begin{array}{l} 9 \\ 7 \\ \text{NO} \end{array} \right\}$	Specify 9- or 7-track tape. 7 indicates support for both.
ALLOC	F1=nK, F2=nK	Specify storage partitioning.
IOTAB		Define the necessary input/output tables for the system.
	BGPGR= $\left\{ \begin{array}{l} 10 \\ n \end{array} \right\}$	Specify the number of logical unit blocks (LUBs) for programmer units, i.e., the number of symbolic programmer logical units (SYS000 - SYSnnn).
	F1PGR= $\left\{ \begin{array}{l} 5 \\ n \end{array} \right\}$	Specify the number of symbolic units of the class SYSnnn for F1.
	F2PGR= $\left\{ \begin{array}{l} 5 \\ n \end{array} \right\}$	Specify the number of symbolic units of the class SYSnnn for F2.
	JIB= $\left\{ \begin{array}{l} 5 \\ n \end{array} \right\}$	Number of JIBs for the system. Minimum value generated is 5.
	CHANQ= $\left\{ \begin{array}{l} 6 \\ n \end{array} \right\}$	Number of entries in the channel queue. Minimum value is 6.
	IODEV= $\left\{ \begin{array}{l} 10 \\ n \end{array} \right\}$	Specify the number of I/O devices attached to the system. The minimum value is 5.
DVCGEN		Specify the physical I/O units attached to the system.
	CHUN=X'cuu'	Hexadecimal number of channel and unit.
	DVCTYP=xxxxxx	Specify the device type. See Figure 2.
	CHANSW= $\left\{ \begin{array}{l} \text{NO} \\ \text{YES} \end{array} \right\}$	YES indicates that the device is attached to more than one selector channel (the device is switchable).
	MODE=X'ss'	<ol style="list-style-type: none"> 1. 2400T9. MODE is used to specify the tape mode. X'C0' is the default value. 2. 2400T7. MODE is used to specify the tape mode. X'90' is the default value. 3. 2702. MODE designates the SADxxx command. X'00' is the default value. X'00' SAD0, X'01' SAD1, X'02' SAD2, X'03' SAD3. 4. 2260 (Local). MODE is used to specify the 1053 printer when CHUN=X'cuu' refers to a 1053 attached to a 2848. This operand must be entered as MODE=X'01'. 5. 1412, 1419, 1259 MODE designates the external interrupt bit associated with magnetic ink character reader. <ul style="list-style-type: none"> X'01' External line 7 X'04' External line 5 X'10' External line 3 X'02' External line 6 X'08' External line 4 X'20' External line 2

Figure 4. Macro Instructions for Supervisor Generation (Part 3 of 4)

Operation	Operand	Explanation
ASSGN		Assign LUBs to PUBs as standard system assignments.
	SYSnnn,X'cuu'	Symbolic unit is assigned a hexadecimal channel and unit number.
SEND	[n]	End of supervisor macro instructions. n = beginning address of the problem program area.

Figure 4. Macro Instructions for Supervisor Generation (Part 4 of 4)

Card Code	Actual Device	Device Type
2400T9	Nine Track Magnetic Tapes	Tapes
2400T7	Seven Track Magnetic Tapes	
1442N1	1442N1 Card Read Punch	Card Readers - Punches
2520B1	2520B1 Card Read Punch	
2501	2501 Card Reader	Card Readers
2540R	2540 Card Reader	
2540P	2540 Card Punch	Card Punches
2520B2	2520B2 Card Punch	
1442N2	1442N2 Card Punch	
2520B3	2520B3 Card Punch	
1403	1403 Printer	Printers
1403U	1403 Printer with UCS Feature	
1404	1404 Printer	
1443	1443 Printer	
1445	1445 Printer	
1050A	1052 Printer- Keyboard	1050 Control Unit
UNSP	Unsupported Device	Unsupported. No Burst Mode on Multiplexor Channel
UNSPB	Unsupported Device	Unsupported with Burst Mode on Multiplexor Channel
2260 (Local)	2260 Display Unit	Display Unit
2260 (Local)	A 1053 attached to a 2848. The mode operand must be entered as MODE=X'01'	Printer

Card Code	Actual Device	Device Type
2311	2311 Disk Drive	DASD
2314	2314 Disk Storage Facility	DASD
2321	2321 Data Cell Drive	DASD
2671	2671 Paper Tape Reader	Paper Tape Reader
2495TC	2495TC Tape Cartridge Reader	Tape Cartridge Reader
1412	1412 Magnetic Character Reader	Magnetic Character Reader
1419	1419 Magnetic Character Reader or 1259 Magnetic Reader	Magnetic Character Reader
1419P	Primary control unit address on 1419 Dual Address Adapter	Magnetic Character Reader
1419S	Secondary control unit address on 1419 Dual Address Adapter	Magnetic Character Reader
2701 *	2701 Line Adapter Unit	Teleprocessing Lines
2702	2702 Transmission Control Unit	
2703	2703 Transmission Control Unit	
2703	IBM System/360 Model 25 with the Integrated Communication attachment.	Teleprocessing Lines
7770	7770 Audio Response Unit	Audio Response
7772	7772 Audio Response Unit	
1285	1285 Optical Reader	Optical Readers
1287	1287 Optical Reader	

* Note: A 2701 Line Adapter Unit attached to an IBM System/360 Model 25 must be placed on the multiplexor channel.

Note: The codes used in DVCGEN macros are identical to those used in IPL statements.

Figure 5. Device Code

Figure 6 shows macro instructions and parameters that generate the supervisors supplied by IBM.

2311 DISK SYSTEM SUPERVISOR		2314 DIRECT ACCESS STORAGE SUPERVISOR	
Operation	Operand	Operation	Operand
SUPVR	SYSTEM = DISK	SUPVR	SYSTEM = DISK
CONFG		CONFG	
STDJC		STDJC	
FOPT	PC = YES	FOPT	PC = YES, SYSFIL = 2314
PIOCS	BMPX = YES, TAPE = 7	PIOCS	BMPX = YES, CHANSW = RWTAU, TAPE = 7
IOTAB		IOTAB	
SEND	6144	SEND	8192
END		END	

● **Figure 6.** IBM-Supplied Supervisor for 2311 Disk Systems and 2314 Direct Access Storage Facility

Two IBM 2311 Disk Drives

The system is supplied in two volumes. The first volume consists of a core image library and a relocatable library. The second volume is composed of a core image library and a source statement library. Depending upon the user's configuration, these packs are used in varying order.

The following is an example of one of the many possible methods for generating a system. Figure 7 illustrates the system configuration upon which Example One (Figure 8) is based. The following steps are keyed to Example One:

Step 1 Disk-only users receive the system on disk. Disk users with at least one tape unit available unit receive the system on tape.

Before generating a system, disk-only users should have at least one initialized disk pack (VTOC on cylinder 199).

Users with two disk drives and at least one tape unit should have at least two initialized disk packs (VTOC on cylinder 199).

Mount the IBM-supplied core image and relocatable library volume. Users with tape must also mount a disk pack to which the tape is to be restored.

Before restoring the tape, the user must take the necessary action to perform or bypass the initialize disk routine.

- a. If the disk packs have not been initialized, the IBM-supplied volume, a self-loading tape, is capable of initializing the packs (see Figure 8). The DLBL cards used in the following steps must contain the volume serial number appearing in the VOL card of the initialize disk control cards. Any volume serial number used in the EXTENT cards for the following steps must agree with the volume serial number in the VOL card for initialize disk control cards.
- b. If the disk packs have been previously initialized, the initialize disk routine can be bypassed (see Figure 8). Any volume serial number used in the EXTENT cards for the following steps must agree with the volume serial number used when the packs were initialized.

Step 2 After step 1 is completed, the user must restore the system from the self-loading tape to the initialized disk pack. This step is omitted when a system is received on disk.

Step 3 When the tape has been restored, dial the address of the system residence disk drive into the load unit switches, and IPL to pass control to the DOS supervisor. See Appendix A for the IPL control statements.

Step 4 Perform a DSERV to display the directories. After determining which components are never to be used, perform a DELETR to delete any relocatable component never to be used.

Step 5 Copy the relocatable library to a second initialized disk, defining it as a private relocatable library. During this

copying, the user can allocate the private library to the desired size. When allocating the size of the private library, consider the workfile requirements discussed in step 9. To compute the minimum size of a library, see Allocating Library Sizes for 2311 and 2314 Disk Systems.

For techniques on copying libraries (MERGE), see Maintenance Procedures.

Step 6 Disk only users, remove the IBM-supplied core image and relocatable library volume, and mount the IBM-supplied core image and source statement library volume.

Disk users that received the IBM-supplied systems on tape should mount the IBM-supplied core image and source statement library system tape, and can either:

- a. replace the system residence pack mounted in step 1, and initialize it, or
- b. bypass initialization (because the system residence pack mounted in step 1 is already initialized).

Step 7 After the previous step is performed, the user must restore the system from the self-loading tape to the initialized pack. This step is omitted when a system is received on disk.

Step 8 When the tape has been restored, dial the address of the system residence disk drive into the load unit switches and IPL to pass control to the DOS supervisor.

Perform a DSERV to display the directories. Then SSERV (display and punch) all the desired sample problems from the source statement library into cards. Punched output includes the sample problems with BKEND and CATALS cards. Four other books in the source statement library that should be punched out at this time (Z.LINKEDIT, Z.DELETECL, Z.DELETERL, and Z.DELETESL) contain the necessary control statements to selectively linkage edit and delete all IBM components. The sample problem program names, and the linkage edit and the delete book names can be chosen and punched into the DSPCH statement(s). The sample problem program names and the linkage edit and delete book names are shown in Appendix C.

After these sample problems and books have been punched, they can be deleted from the source statement library, along with unwanted macros (e.g., those macros never to be used).

Step 9 Define workfiles for SYSLNK, SYS001, SYS002, and SYS003 to the second drive. The workfiles SYSLNK, SYS001, SYS002, and SYS003 are defined by use of the DLBL and EXTENT cards. These cards must be preceded by the OPTION STDLABEL or OPTION PARSTD card.

Step 10 Perform all necessary assemblies. The assemblies for the supervisor, IOCS modules, and emulator should be performed as separate jobs. For the information required to assemble Emulator Programs, refer to the Emulator Program manual listed in the Preface. The user must be careful to keep all assemblies in order.

Step 11 Assemble all user-required IOCS modules. By assigning SYSPCH to a tape unit, the IOCS modules can be cataloged to the relocatable library without punching them on cards. The IOCS modules required by COBOL, PL/I, and RPG, as defined in Appendix B, are supplied in the relocatable library by IBM.

Close the tape assigned to SYSPCH and reassign SYSPCH to its permanent assignment by using the CLOSE command. The assembly listings should be checked for errors before proceeding.

- Step 12 Delete unwanted macros from the source statement library, and then create a private source statement library. If space allows, this copy could be made to a free area of the pack to which the relocatable library was copied.

For techniques on creating a new library, see Maintenance Procedures.

- Step 13 This step defines the creation of the core image library of the user's operational pack.

The user can either delete the source statement library and reallocate the system to create a large core image library, or reallocate to create a large core image and a small system source statement library on the operational pack.

For techniques on creating a new library, see Maintenance Procedures.

- Step 14 During this step the user must have the core image library of his operational pack that he is building on line, as well as his relocatable library.

If linkage edit work files are not assigned, they must be assigned now.

Linkage edit and catalog the assembled supervisor (object module from step 10) to the core image library. If the SEND address is larger than the one used by the supervisor being replaced, certain key programs must also be linkage edited and cataloged to the core image library in the same job step with the new supervisor. These key programs are IPL, linkage editor, and librarian. The LINKEDIT deck punched out in step 8 contains all of the necessary control statements to linkage edit all IBM components shipped on the system. If the SEND address is not exceeded, only the supervisor need be cataloged. The new supervisor is not cataloged until a /& statement is read. The user must not attempt any other operation from the time the supervisor and these preceding programs are cataloged until IPL time.

- Step 15 Re-IPL and set the date (and clock if the Timer Feature is present).

Linkage edit and catalog any additional components desired to the core image library. See Appendix C for a complete list of control cards for all IBM components to be cataloged. Before the next step is performed, check the linkage editor listings, and make all necessary corrections.

- Step 16 Reload the tape that was assigned to SYSPCH in step 11 and assign it to SYSIPT. With this tape the MAINT program catalogs the IOCS modules to the relocatable library by the control card // EXEC MAINT. The user may set new standard labels (OPTION STDLABEL), reallocate library sizes, and set automatic condense limits, if required. Backup for the operational disk can be obtained by copying the operational disk pack to tape by using the copy disk-to-tape utility program.

INPUT/OUTPUT DEVICE CONFIGURATION FOR EXAMPLE ONE (SEE FIGURE 7)

<u>Device</u>	<u>Channel</u>	<u>Unit</u>	<u>Use</u>
2540R	0	0C	Card Reader (SYSRDR, SYSIPT)
2540P	0	0D	Card Punch (SYSPCH)
1403	0	0E	Printer (SYSLST)
1052	0	1F	Printer-Keyboard (SYSLOG)
2311	1	91	Disk (SYSLNK, SYS001, SYS002, SYS003, SYS004, SYSRLB, SYSSLB)
2311	1	90	Disk (SYSRES)
2321	1	92	Data Cell (SYS007)
2400T7	1	80	Magnetic tape with the data conversion feature (switchable to channel 2)
2400T9	1	81	Magnetic tape (switchable to channel 2)

Example One: Results of System Generation

When system generation is completed for example one (see Figure 8), the operational disk of the installation contains: Assembler, Basic FORTRAN, COBOL, RPG, PL/I, Autotest, all utilities, and the disk sort/merge programs in its core image library together with the installation's tailored supervisor, job control, linkage editor, and librarian programs. The tape shipped by IBM is retained as a backup tape. It is a selfloading tape capable of being restored onto disk.

The sample problems are punched out during step 8.

The private relocatable and source statement libraries contain all modules and macro definitions shipped from IBM (except teleprocessing, OLTEP, Assembler F, Tape Sort/Merge, and the Vocabulary file utility).

The core image library of the operational pack is built to contain those IBM programs chosen by the user.

At this point, the private libraries are condensed, and user IOCS modules are assembled and cataloged to the private relocatable library.

When system generation is completed, the sample problems should be run against the operational pack to ensure correct creation of all system programs.

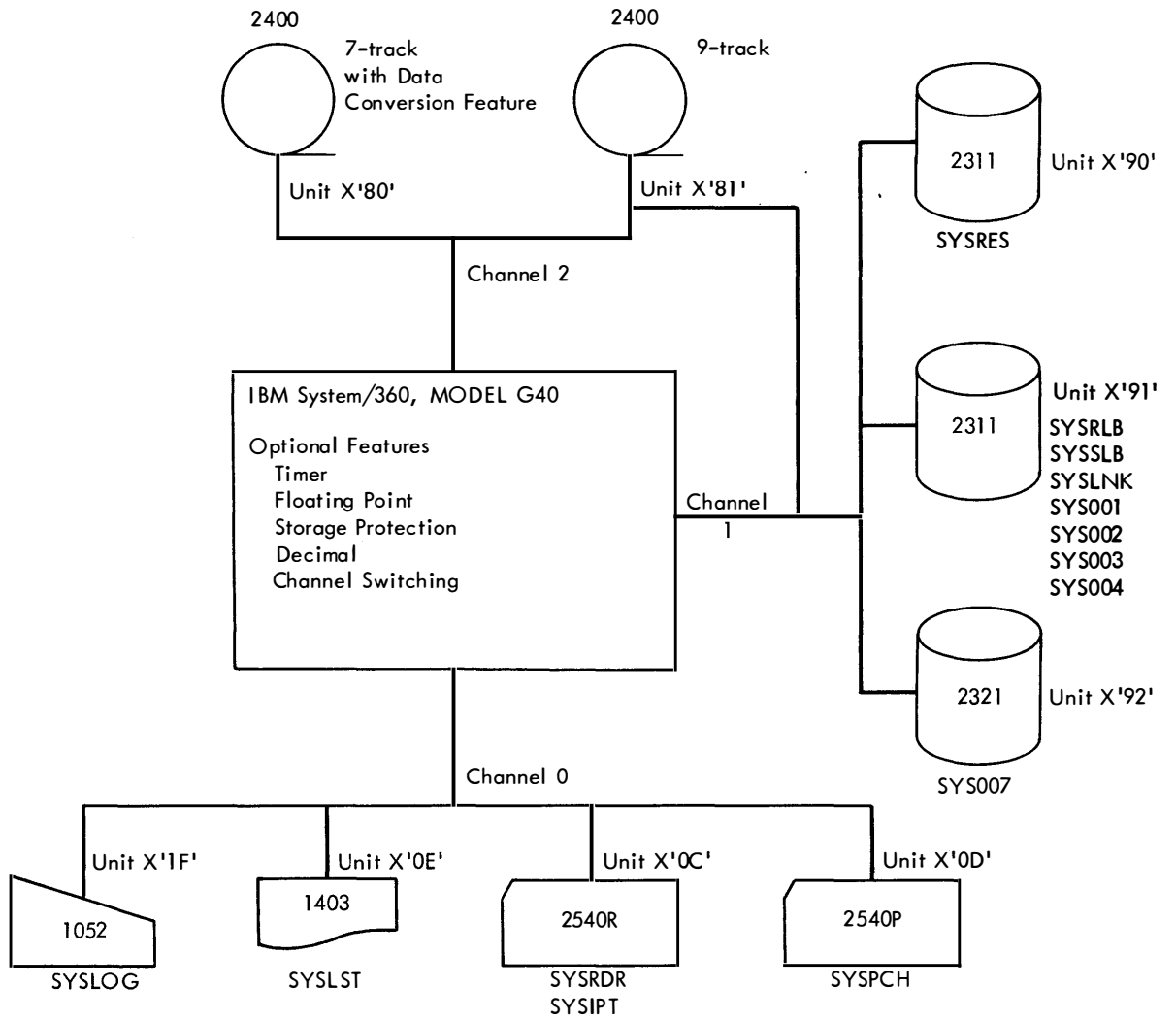

Figure 7. System Configuration for Example One

IBM	IBM System/360 Assembler Coding Form	PAGE	OF
PROGRAM	EXAMPLE ONE: TWO DISK DRIVES	PUNCHING INSTRUCTIONS	GRAPHIC PUNCH
PROGRAMMER	STEP 1a	DATE	CARD ELECTRO NUMBER
Name		Operation	Statement
1	8	10	14
16	20	25	30
35	40	45	50
55	60	65	70
75	80	85	90
<p>The user may optionally bypass the initialize routine. However, if initialization is required mount a pack on unit 190, mount a second pack on unit 191. Mount IBM-supplied tape on unit 181 (9-track drive). Place the following cards in the card reader. Dial 181 in the load unit switches and press load. When system enters the wait state press start and EOF on the card reader. To initialize the second pack, change the assignment for SYSLOG to // ASSGN SYSOPT, X'191',D1; rewind the IBM-supplied tape mounted on 181, reload the card reader with the following cards, and press load. When the system enters the wait state press start and EOF on the card reader. Use of multi-part forms is suggested as copies of the linkage editor maps and the supervisor listing will be required by your IBM customer engineer for maintenance purposes.</p>			
//	JOB	INTDSK	
//	DATE	69032	
//	ASSGN	SYSLOG, X'01F', C1	
//	ASSGN	SYSOPT, X'191', D1	
//	EXEC		
//	UID	IR, C1	
//	VTOC	STR TADR = (0199000), EXTENT = (9)	
VOL	1111111		
//	END		

IBM	IBM System/360 Assembler Coding Form	PAGE	OF
PROGRAM	EXAMPLE ONE: TWO DISK DRIVES	PUNCHING INSTRUCTIONS	GRAPHIC PUNCH
PROGRAMMER	STEP 1b	DATE	CARD ELECTRO NUMBER
Name		Operation	Statement
1	8	10	14
16	20	25	30
35	40	45	50
55	60	65	70
75	80	85	90
<p>To bypass initialize disk program on IBM-supplied tape. Mount IBM-supplied tape on unit 181 (9-track drive). Mount initialized disk on unit 190 (VTOC on cyl 199). Mount work pack on 191 insert the following control cards in the reader. Dial 181 in load unit switches. Press load key. When system enters wait state, press start and EOF on the card reader. Job is complete when 00C and 4000A messages are logged.</p>			
//	JOB	INTDSK	
//	DATE	69032	
//	ASSGN	SYSLOG, X'01F', C1	
//	FILES	SYSIPT, 1	

Figure 8. Example One (Part 1 of 14)

PROGRAM		EXAMPLE ONE: TWO DISK DRIVES		PUNCHING INSTRUCTIONS		GRAPHIC PUNCH		PAGE OF		CARD ELECTRO NUMBER											
PROGRAMMER		STEP 2		DATE		STATEMENT		Comments		Identification Sequence											
1	Name	8	10	Operation	14	16	20	Operation	24	30	35	40	45	50	55	Comments	60	65	71	73	80
<p>**** Caution **** Do not rewind unit 181. To load the tape onto disk, place the following cards in the reader. Dial 181 in load switches. Press load. When the system enters the wait state, press start and EOF on card reader. The following message appears on SYSLOG: 4444A. Type in 4 (B) and press INTERRUPT to continue.</p>																					
// JOB DISRST																					
// DATE 69032																					
// ASSGN SYS000,X'190',D1																					
// ASSGN SYSLOG,X'01F',C1																					
// ASSGN SYSLSST,X'00E',L1																					
// EXEC																					

PROGRAM		EXAMPLE ONE: TWO DISK DRIVES		PUNCHING INSTRUCTIONS		GRAPHIC PUNCH		PAGE OF		CARD ELECTRO NUMBER											
PROGRAMMER		STEP 3		DATE		STATEMENT		Comments		Identification Sequence											
1	Name	8	10	Operation	14	16	20	Operation	24	30	35	40	45	50	55	Comments	60	65	71	73	80
<p>After the system is loaded onto disk generate the installation system. Dial 190 in load unit switches. Press load key on console. When system enters the wait state, press start on the card reader. The following cards are in the card reader (SYSRDR/ SYSIPT).</p>																					
ADD X'00C',2540R																					
ADD X'00D',2540P																					
ADD X'00E',1403																					
ADD X'01F',1050A																					
ADD X'190',2311																					
ADD X'191',2311																					
SET DATE=02/01/69,CLOCK=00/00/00																					
ASSGN SYSLOG,X'01F'																					
LOG																					
ASSGN SYSRDR,X'00C'																					
ASSGN SYSIPT,X'00C'																					
ASSGN SYSPCH,X'00D'																					
ASSGN SYSLSST,X'00E'																					

Figure 8. Example One (Part 2 of 14)

IBM	IBM System 360 Assembler Coding Form	326-400P Printed in U.S.A.	
PROGRAM	EXAMPLE ONE: TWO DISK DRIVES	PAGE	OF
PROGRAMMER	STEP 4	DATE	
	FUNCTIONING INSTRUCTIONS	GRAPHIC RUNCH	
			CARD ELECTED NUMBER

1	Name	8	10	Operation	14	16	20	Operand	23	30	35	Statement	40	45	50	Comments	60	65	71	73	Identification Sequence	80	
	//	J	O	B	D	S	E	R	V	R	L	B											
	//	E	X	E	C	D	S	E	R	V													
		D	S	P	L	Y	A	L	L														
	//	*																					
	//	E	X	E	C	M	A	I	N	T													
		D	E	L	E	T	R	I	J	L	.	A	L	L	,	I	J	N	.	A	L	L	
		D	E	L	E	T	R	I	J	P	.	A	L	L	,	I	J	Y	.	A	L	L	,
		D	E	L	E	T	R	I	J	K	S	Y	S	A	,	I	J	K	S	Y	S	I	
		R	E	N	A	M	R	I	J	X	S	Y	S	A	,	I	J	X	S	Y	S	I	,
	//	*																					
	//	&																					

IBM	IBM System 360 Assembler Coding Form	326-400P Printed in U.S.A.	
PROGRAM	EXAMPLE ONE: TWO DISK DRIVES	PAGE	OF
PROGRAMMER	STEP 5	DATE	
	FUNCTIONING INSTRUCTIONS	GRAPHIC RUNCH	
			CARD ELECTED NUMBER

1	Name	8	10	Operation	14	16	20	Operand	23	30	35	Statement	40	45	50	Comments	60	65	71	73	Identification Sequence	80	
		If a small private relocatable library is to be built on the operational system, remove the pack from 191 and mount the initialized pack that the operational system is to be built on. Then, repeat this job with the proper EXTENT and NEWVOL statements.																					
	//	J	O	B	P	V	T	R	L	B													
	//	A	S	S	G	N	S	Y	S	R	L	B	.	X	'	1	9	1					
	//	D	L	B	L	I	J	S	Y	S	R	L	.	'	D	O	S	P	V	T	R	E	L
	//	E	X	T	E	N	T	S	Y	S	R	L	B	.	n	n	n	n	n	.	1	.	1
	//	E	X	E	C	C	O	R	G	Z													
		N	E	W	V	O	L	R	L	=	n	n	(n)								
		C	O	P	Y	R	A	L	L														
	//	*																					
	//	&																					
	//	P	A	U	S	E																	

Figure 8. Example One (Part 3 of 14)

IBM		IBM System/360 Assembler Coding Form						IBM-400 Printed in U.S.A.											
PROGRAM	EXAMPLE ONE: TWO DISK DRIVES	PUNCHING INSTRUCTIONS	GRAPHIC PUNCH	PAGE	OF	CARD ELECTRO NUMBER													
PROGRAMMER	STEP 6a	DATE	STATEMENT	Comments		Identification-Sequence													
1	Name	8	10	Operation	14	16	20	25	30	35	40	45	50	55	60	65	70	75	80
<p>The user may optionally bypass the initialize routine. However, if initialization is required mount a pack on unit 190, mount a second pack on unit 191. Mount IBM-supplied tape on unit 181 (9-track drive). Place the following cards in the card reader. Dial 181 in the load unit switches and press load. When system enters the wait state press start and EOF on the card reader. Use of multi-part forms is suggested as copies of the linkage editor maps and the supervisor listing will be required by your IBM customer engineer for maintenance purposes.</p>																			
// JOB INTOSK																			
// DATE 69032																			
// ASSGN SYSLOG,X'01F',C1																			
// ASSGN SYSOPT,X'190',D1																			
// EXEC																			
// UID IR,C1																			
// VTOC STRTADR=(0199000),EXTENT=(9)																			
VOL1111111																			
// END																			

IBM		IBM System/360 Assembler Coding Form						IBM-400 Printed in U.S.A.											
PROGRAM	EXAMPLE ONE: TWO DISK DRIVES	PUNCHING INSTRUCTIONS	GRAPHIC PUNCH	PAGE	OF	CARD ELECTRO NUMBER													
PROGRAMMER	STEP 6b	DATE	STATEMENT	Comments		Identification-Sequence													
1	Name	8	10	Operation	14	16	20	25	30	35	40	45	50	55	60	65	70	75	80
<p>To bypass initialize disk program on IBM-supplied tape. Mount IBM-supplied tape on unit 181 (9-track drive). Mount initialized disk on unit 190 (VTOC on cyl 199). Mount work pack on 191 insert the following control cards in the reader. Dial 181 in load unit switches. Press load key. When system enters wait state, press start and EOF on the card reader. Job is complete when 00C and 4000A messages are logged.</p>																			
// JOB INTOSK																			
// DATE 69032																			
// ASSGN SYSLOG,X'01F',C1																			
// FILES SYSOPT,1																			

Figure 8. Example One (Part 4 of 14)

IBM	IBM System/360 Assembler Coding Form	PAGE	OF
PROGRAM	EXAMPLE ONE: TWO DISK DRIVES	DATE	
PROGRAMMER	STEP 7	FUNCHING INSTRUCTIONS	GRAPHIC PUNCH
STATEMENT		Comments	Identification-Sequence
1	Name	8	10
	Operation	14	16
	Operand	20	25
		30	35
		40	45
		50	55
		60	65
		70	75
		80	85
		90	95
<p>**** Caution **** Do not rewind unit 181. To load the tape onto disk, place the following cards in the reader. Dial 181 in load switches. Press load. When the system enters the wait state, press start and EOF on card reader. The following message appears on SYSLOG: 4444A. Type in 4 (E) and press INTERRUPT to continue.</p> <pre>// JOB DISRST // DATE 69032 // ASSGN SYS000,X'190',D1 // ASSGN SYSLOG,X'01F',C1 // ASSGN SYSLST,X'00E',L1 // EXEC</pre>			

IBM	IBM System/360 Assembler Coding Form	PAGE	OF
PROGRAM	EXA PLE ONE: TWO DISK DRIVES	DATE	
PROGRAMMER	STEP 8	FUNCHING INSTRUCTIONS	GRAPHIC PUNCH
STATEMENT		Comments	Identification-Sequence
1	Name	8	10
	Operation	14	16
	Operand	20	25
		30	35
		40	45
		50	55
		60	65
		70	75
		80	85
		90	95
<p>After the system is loaded onto disk,generate the installation system. Dial 190 in load unit switches. Press load key on console. When system enters the wait state, press start on the card reader. The following cards are in the card reader (SYSRDR/SYSIPT).</p> <pre>ADD X'00C',2540R ADD X'00D',2540P ADD X'00E',1403 ADD X'01F',1050A ADD X'190',2311 ADD X'191',2311 ADD X'181',2400T9</pre>			

Figure 8. Example One (Part 5 of 14)

IBM		IBM System/360 Assembler Coding Form										PAGE OF																					
PROGRAM		EXAMPLE ONE: TWO DISK DRIVES										PAGE		OF																			
PROGRAMMER		STEP 8 (continued)										CARD ELECTRO NUMBER																					
NAME		OPERATION										COMMENTS		IDENTIFICATION																			
1		25										30		35		40		45		50		55		60		65		70		75		80	
SET		DATE=02/01/69,CLOCK=00/00/00																															
ASISGN		SYSLOG,X'01F'																															
LOG																																	
ASISGN		SYSRDIR,X'00C'																															
ASISGN		SYSIPT,X'00C'																															
ASISGN		SYSPCH,X'00D'																															
ASISGN		SYSLSL,X'00E'																															
ASISGN		SYS001,X'191'																															
ASISGN		SYS002,X'191'																															
ASISGN		SYS003,X'191'																															

IBM		IBM System/360 Assembler Coding Form										PAGE OF																					
PROGRAM		EXAMPLE ONE: TWO DISK DRIVES										PAGE		OF																			
PROGRAMMER		STEP 8 (continued)										CARD ELECTRO NUMBER																					
NAME		OPERATION										COMMENTS		IDENTIFICATION																			
1		25										30		35		40		45		50		55		60		65		70		75		80	
//		JOB DSERVSLB																															
//		EXEC DSERV																															
DISP		LY ALL																															
//		*																															
//		EXEC SSERV																															
DISP		LY A.DOSCHLV										Display the change level.																					
DISP		CH Z.ALL										Display and punch sample problems, delete, and link edit books. See Appendix C for names.																					
//		*																															
//		PAUSE REMOVE CARDS FROM SYSPCH. PRESS EOB TO CONTINUE.																															
//		&																															

Figure 8. Example One (Part 6 of 14)

IBM		IBM System 360 Assembler Coding Form										PAGE		OF						
PROGRAM		EXAMPLE ONE: TWO DISK DRIVES										PAGE		OF						
PROGRAMMER		STEP 9										CARD ELECTRO NUMBER								
1	Name			Operation			Operand			Comments			71		72		Identification Sequence		80	
//	JOB	ASSEMBLY																		
//	OPTION	DECK,LIST,LOG,STDLABEL																		
//	DLBL	IJSYS01,'SYSTEM WORK FILE NO. 1',99/365,SD																		
//	EXTENT	SYS001,nnnnnn,1,n,nnnn,nnnn																		
//	DLBL	IJSYS02,'SYSTEM WORK FILE NO. 2',99/365,SD																		
//	EXTENT	SYS002,nnnnnn,1,n,nnnn,nnnn																		
//	DLBL	IJSYS03,'SYSTEM WORK FILE NO. 3',99/365,SD																		
//	EXTENT	SYS003,nnnnnn,1,n,nnnn,nnnn																		
//	DLBL	IJSYSRL,'DOS PVT REL LIB',99/365,SD																		
//	EXTENT	SYSRLB,nnnnnn,1,1,nnnn,nnnn																		

IBM		IBM System 360 Assembler Coding Form										PAGE		OF						
PROGRAM		EXAMPLE ONE: TWO DISK DRIVES										PAGE		OF						
PROGRAMMER		STEP 10										CARD ELECTRO NUMBER								
1	Name			Operation			Operand			Comments			71		72		Identification Sequence		80	
//	EXEC	ASSEMBLY																		
		SUPVR	SYSTEM=DISK,MPS=YES																	
		CONFG	MODEL=40,SP=YES,DIEC=YES,FP=YES,TIMER=YES																	
		STDJC	LISTX=YES,LINES=46																	
		FOPT	IT=BG,PC=YES,OC=YES,CCHAIN=YES,DASDFP=(1,2,2321),																	
			SYSFIL=(2311),TEB=4																	
		PIOC	CHANSW=RWTAU,TAPE=7,BMPX=YES																	
		ALLOC	F1=6K,F2=6K																	
		IOTAB	JIB=10,CHANQ=10,F1PGR=8,F2PGR=8,IODEV=10,BGPGR=10																	
		DVCGEN	CHUN=X'00C',DVCTYP=2540R																	
		DVCGEN	CHUN=X'00D',DVCTYP=2540P																	
		DVCGEN	CHUN=X'00E',DVCTYP=1403																	
		DVCGEN	CHUN=X'01F',DVCTYP=1050A																	
		DVCGEN	CHUN=X'190',DVCTYP=2311																	
		DVCGEN	CHUN=X'191',DVCTYP=2311																	
		DVCGEN	CHUN=X'192',DVCTYP=2321																	
		DVCGEN	CHUN=X'180',DVCTYP=2400T7,CHANSW=YES																	
		DVCGEN	CHUN=X'181',DVCTYP=2400T9,CHANSW=YES																	

Figure 8. Example One (Part 7 of 14)

IBM		IBM System 360 Assembler Coding Form		PAGE 08	
PROGRAM		EXAMPLE ONE: TWO DISK DRIVES		PAGE 08	
PROGRAMMER		STEP 14		CARD ELECTRO NUMBER	
1	2	3	4	5	6
7	8	9	10	11	12
13	14	15	16	17	18
19	20	21	22	23	24
25	26	27	28	29	30
31	32	33	34	35	36
37	38	39	40	41	42
43	44	45	46	47	48
49	50	51	52	53	54
55	56	57	58	59	60
61	62	63	64	65	66
67	68	69	70	71	72
73	74	75	76	77	78
79	80	81	82	83	84
85	86	87	88	89	90
91	92	93	94	95	96
97	98	99	100	101	102
103	104	105	106	107	108
109	110	111	112	113	114
115	116	117	118	119	120
121	122	123	124	125	126
127	128	129	130	131	132
133	134	135	136	137	138
139	140	141	142	143	144
145	146	147	148	149	150
151	152	153	154	155	156
157	158	159	160	161	162
163	164	165	166	167	168
169	170	171	172	173	174
175	176	177	178	179	180
181	182	183	184	185	186
187	188	189	190	191	192
193	194	195	196	197	198
199	200	201	202	203	204
205	206	207	208	209	210
211	212	213	214	215	216
217	218	219	220	221	222
223	224	225	226	227	228
229	230	231	232	233	234
235	236	237	238	239	240
241	242	243	244	245	246
247	248	249	250	251	252
253	254	255	256	257	258
259	260	261	262	263	264
265	266	267	268	269	270
271	272	273	274	275	276
277	278	279	280	281	282
283	284	285	286	287	288
289	290	291	292	293	294
295	296	297	298	299	300
301	302	303	304	305	306
307	308	309	310	311	312
313	314	315	316	317	318
319	320	321	322	323	324
325	326	327	328	329	330
331	332	333	334	335	336
337	338	339	340	341	342
343	344	345	346	347	348
349	350	351	352	353	354
355	356	357	358	359	360
361	362	363	364	365	366
367	368	369	370	371	372
373	374	375	376	377	378
379	380	381	382	383	384
385	386	387	388	389	390
391	392	393	394	395	396
397	398	399	400	401	402
403	404	405	406	407	408
409	410	411	412	413	414
415	416	417	418	419	420
421	422	423	424	425	426
427	428	429	430	431	432
433	434	435	436	437	438
439	440	441	442	443	444
445	446	447	448	449	450
451	452	453	454	455	456
457	458	459	460	461	462
463	464	465	466	467	468
469	470	471	472	473	474
475	476	477	478	479	480
481	482	483	484	485	486
487	488	489	490	491	492
493	494	495	496	497	498
499	500	501	502	503	504
505	506	507	508	509	510
511	512	513	514	515	516
517	518	519	520	521	522
523	524	525	526	527	528
529	530	531	532	533	534
535	536	537	538	539	540
541	542	543	544	545	546
547	548	549	550	551	552
553	554	555	556	557	558
559	560	561	562	563	564
565	566	567	568	569	570
571	572	573	574	575	576
577	578	579	580	581	582
583	584	585	586	587	588
589	590	591	592	593	594
595	596	597	598	599	600
601	602	603	604	605	606
607	608	609	610	611	612
613	614	615	616	617	618
619	620	621	622	623	624
625	626	627	628	629	630
631	632	633	634	635	636
637	638	639	640	641	642
643	644	645	646	647	648
649	650	651	652	653	654
655	656	657	658	659	660
661	662	663	664	665	666
667	668	669	670	671	672
673	674	675	676	677	678
679	680	681	682	683	684
685	686	687	688	689	690
691	692	693	694	695	696
697	698	699	700	701	702
703	704	705	706	707	708
709	710	711	712	713	714
715	716	717	718	719	720
721	722	723	724	725	726
727	728	729	730	731	732
733	734	735	736	737	738
739	740	741	742	743	744
745	746	747	748	749	750
751	752	753	754	755	756
757	758	759	760	761	762
763	764	765	766	767	768
769	770	771	772	773	774
775	776	777	778	779	780
781	782	783	784	785	786
787	788	789	790	791	792
793	794	795	796	797	798
799	800	801	802	803	804
805	806	807	808	809	810
811	812	813	814	815	816
817	818	819	820	821	822
823	824	825	826	827	828
829	830	831	832	833	834
835	836	837	838	839	840
841	842	843	844	845	846
847	848	849	850	851	852
853	854	855	856	857	858
859	860	861	862	863	864
865	866	867	868	869	870
871	872	873	874	875	876
877	878	879	880	881	882
883	884	885	886	887	888
889	890	891	892	893	894
895	896	897	898	899	900
901	902	903	904	905	906
907	908	909	910	911	912
913	914	915	916	917	918
919	920	921	922	923	924
925	926	927	928	929	930
931	932	933	934	935	936
937	938	939	940	941	942
943	944	945	946	947	948
949	950	951	952	953	954
955	956	957	958	959	960
961	962	963	964	965	966
967	968	969	970	971	972
973	974	975	976	977	978
979	980	981	982	983	984
985	986	987	988	989	990
991	992	993	994	995	996
997	998	999	1000	1001	1002

Steps 14 and 15 contain the coding for including the IBM components selected for this example. The LINKEDIT book displayed and punched in step 8 contains all the necessary job control statements to linkage edit any of the IBM components shipped on the system. The user is encouraged to use this book to tailor a job stream to include any IBM components desired.

Need not be linkage edited if the shipped supervisor is not exceeded.

IBM		IBM System 360 Assembler Coding Form		PAGE 09	
PROGRAM		EXAMPLE ONE: TWO DISK DRIVES		PAGE 09	
PROGRAMMER		STEP 14 (continued)		CARD ELECTRO NUMBER	
1	2	3	4	5	6
7	8	9	10	11	12
13	14	15	16	17	18
19	20	21	22	23	24
25	26	27	28	29	30
31	32	33	34	35	36
37	38	39	40	41	42
43	44	45	46	47	48
49	50	51	52	53	54
55	56	57	58	59	60
61	62	63	64	65	66
67	68	69	70	71	72
73	74	75	76	77	78
79	80	81	82	83	84
85	86	87	88	89	90
91	92	93	94	95	96
97	98	99	100	101	102
103	104	105	106	107	108
109	110	111	112	113	114
115	116	117	118	119	120
121	122	123	124	125	126
127	128	129	130	131	132
133	134	135	136	137	138
139	140	141	142	143	144
145	146	147	148	149	150
151	152	153	154	155	156
157	158	159	160	161	162
163	164	165	166	167	168
169	170	171	172	173	174
175	176	177	178	179	180
181	182	183	184	1	

IBM		IBM System 360 Assembler Coding Form										PAGE OF								
PROGRAM	EXAMPLE ONE: TWO DISK DRIVES	PLANNING	DATE	FINISH	DATE	FINISH	DATE	FINISH	DATE	FINISH	DATE	CARD ELECTRIC NUMBER								
PROGRAMMER	STEP 15																			
Name	8	10	Operation	14	16	20	25	30	35	40	45	50	55	Comments	60	65	70	75	80	Identification Sequence
//			JOB	CATAL	CLB															
*	AT THIS POINT LINKAGE EDIT COBOL BASIC FORTRAN DISK SORT MERGE																			
*	UTILITIES AUTOTEST PL/I RPG 14K ASSEMBLER																			
//			OPTION	CATAL																
			ACTION	CLEAR																
			INCLUDE	IJ	VPT															
//			EXEC	LNKEDT																
			INCLUDE	IJ	SCBD															
//			EXEC	LNKEDT																
			INCLUDE	IJ	SODB															
//			EXEC	LNKEDT																
			INCLUDE	IJ	TFO															
//			EXEC	LNKEDT																
			INCLUDE	IJ	XPLID															
//			EXEC	LNKEDT																
			INCLUDE	IJ	RIG															
//			EXEC	LNKEDT																
			INCLUDE	IJ	OSM															
//			EXEC	LNKEDT																
			INCLUDE	IJ	QD32															
//			EXEC	LNKEDT																

IBM		IBM System 360 Assembler Coding Form										PAGE OF								
PROGRAM	EXAMPLE ONE: TWO DISK DRIVES	PLANNING	DATE	FINISH	DATE	FINISH	DATE	FINISH	DATE	FINISH	DATE	CARD ELECTRIC NUMBER								
PROGRAMMER	STEP 15 (continued)																			
Name	8	10	Operation	14	16	20	25	30	35	40	45	50	55	Comments	60	65	70	75	80	Identification Sequence
			INCLUDE	IJ	WTM															
			PHASE	TP	DC5															
			INCLUDE	IJ	WLAB															
//			LBLTYP	TAPE																
//			EXEC	LNKEDT																
			INCLUDE	IJ	WTD															
			PHASE	TP	DK5															
			INCLUDE	IJ	WLAB															
//			LBLTYP	TAPE																
//			EXEC	LNKEDT																
			INCLUDE	IJ	WTP															
			PHASE	TP	PR5															
			INCLUDE	IJ	WLAB															
//			LBLTYP	TAPE																
//			EXEC	LNKEDT																
			INCLUDE	IJ	WTC															
			PHASE	TP	CD5															
			INCLUDE	IJ	WLAB															
//			LBLTYP	TAPE																
//			EXEC	LNKEDT																

Figure 8. Example One (Part 12 of 14)

Name		Operation	Operand	Comments	Identification Sequence
1	INCLUDE	IJWCT		CARD TO TAPE UTILITY	
	PHASE	CDTP5, IJWCTCS2, NOAUTO			
	INCLUDE	IJWLAB			
	//	LBLTYP TAPE			
	//	EXEC LNKEDT			
	INCLUDE	IJWCD		CARD TO DISK UTILITY	
	PHASE	CDK5, IJWCDCS2, NOAUTO			
	INCLUDE	IJWLAB			
	//	EXEC LNKEDT			
	INCLUDE	IJWCP		CARD TO PRINTER/PUNCH UTILITY	
	PHASE	CDPP5, IJWCPCS2, NOAUTO			
	INCLUDE	IJWLAB			
	//	EXEC LNKEDT			
	INCLUDE	IJWDP		DISK TO PRINTER UTILITY	
	PHASE	DKPR5, IJWDPSCS2, NOAUTO			
	INCLUDE	IJWLAB			
	//	EXEC LNKEDT			
	INCLUDE	IJWDC		DISK TO CARD UTILITY	
	PHASE	DKCD5, IJWDCSCS2, NOAUTO			
	INCLUDE	IJWLAB			
	//	EXEC LNKEDT			

Name		Operation	Operand	Comments	Identification Sequence
1	INCLUDE	IJWDT		DISK TO TAPE UTILITY	
	PHASE	DKTP5, IJWDTCS2, NOAUTO			
	INCLUDE	IJWLAB			
	//	LBLTYP TAPE			
	//	EXEC LNKEDT			
	INCLUDE	IJWDM		DISK TO DATA CELL UTILITY	
	PHASE	DKDC5, IJWDMCS2, NOAUTO			
	INCLUDE	IJWLAB			
	//	EXEC LNKEDT			
	INCLUDE	IJWDD		DISK TO DISK UTILITY	
	PHASE	DKDK5, IJWDDCS2, NOAUTO			
	INCLUDE	IJWLAB			
	//	EXEC LNKEDT			
	INCLUDE	IJWMD		DATA CELL TO DISK UTILITY	
	PHASE	DCDK5, IJWMDCS2, NOAUTO			
	INCLUDE	IJWLAB			
	//	EXEC LNKEDT			
	INCLUDE	IJWMT		DATA CELL TO TAPE UTILITY	
	PHASE	DCTP5, IJWMTCS2, NOAUTO			
	INCLUDE	IJWLAB			
	//	LBLTYP TAPE			
	//	EXEC LNKEDT			

Figure 8. Example One (Part 13 of 14)

IBM		IBM System 360 Assembler Coding Form				PAGE OF	
PROGRAM	EXAMPLE ONE: TWO DISK DRIVES			PUNCHING INSTRUCTIONS	GRAPHIC PUNCH	CARD ELECTRO NUMBER	
PROGRAMMER	STEP 15 (continued)			DATE	START TIME		
Name	Operation	Comment	Comments	Comments	Comments	Comments	Identification
1	I	INCLUDE	IJWMP		DATA CELL TO PRINTER UTILITY		
		PHASE	DCPR5,IJWMP,CS2,NOAUTO				
		I	INCLUDE	IJWLAB			
		//	EXEC	LNKEDT			
		I	INCLUDE	IJWMM	DATA CELL TO DATA CELL UTILITY		
		PHASE	DCDC5,IJWMM,CS2,NOAUTO				
		I	INCLUDE	IJWLAB			
		//	EXEC	LNKEDT			
		I	INCLUDE	IJWCLD	CLEAR DISK UTILITY		
		//	EXEC	LNKEDT			
		I	INCLUDE	IJWCLM	CLEAR DATA CELL UTILITY		
		//	EXEC	LNKEDT			
		PHASE	TPCP,*,NOAUTO		TAPE COMPARE UTILITY		
		I	INCLUDE	IJWTCP			
		I	INCLUDE	IJJCPD1			
		I	INCLUDE	IJWXIT			
		I	INCLUDE	IJWTPCP			
		//	LBLTYP	TAPE			
		//	EXEC	LNKEDT			
		//	*				
		//	&				
		//	JOB	CATALRLIB			

IBM		IBM System 360 Assembler Coding Form				PAGE OF	
PROGRAM	EXAMPLE ONE: TWO DISK DRIVES			PUNCHING INSTRUCTIONS	GRAPHIC PUNCH	CARD ELECTRO NUMBER	
PROGRAMMER	STEP 16			DATE	START TIME		
Name	Operation	Comment	Comments	Comments	Comments	Comments	Identification
1	//	ASSIGN	SYSIPT,X'181'				
	*	CATALOG	MODULES TO RELOCATABLE LIBRARY				
	//	EXEC	MAINT				
	//	*					
	*	THE FOLLOWING	DELETIONS ARE OPTIONAL.				
	//	PAUSE	PLACE REMAINING CARDS IN READER. PRESS EOB TO CONTINUE				
	//	EXEC	MAINT				
		Place any desired deletes here.					
		CONDS	RL,SL				
	//	*					
	//	&					
	*	THE BASIC	SYSGEN IS COMPLETE. THE USER MAY SET NEW STANDARD				
	*	LABELS, RE-ALLOCATE	LIBRARY SIZES, AND SET AUTOMATIC CONDENSE				
	*	LIMITS IF REQUIRED, COPY	THE OPERATIONAL PACK TO TAPE FOR BACK-UP.				
	*	USE THE IDENTICAL	UTILITY DECK SETUP AS AFTER FIRST SYSGEN JOB.				
	*	THE FINAL	CONDENSE OPERATION SUPPLIED THE CURRENT STATUS				
	*	OF THE SYSTEM	LIBRARIES.				
	//	PAUSE	EOJ SYSGEN----				

Figure 8. Example One (Part 14 of 14)

One IBM 2311 Disk Drive

The system is supplied in two volumes. The first volume consists of a core image library and a relocatable library. The second volume is composed of a core image library and a source statement library. Depending upon the user's configuration, these packs are used in varying order.

IBM supplies the 10K background variant of the disk work file assembler in the core image library of the source statement library pack. The following procedure employs this assembler variant for system generation. If the user wishes to use another variant, he must:

- Linkage edit and catalog the desired assembler to the core image library of the relocatable library system.
- CSERV the assembler just cataloged.
- Delete the supplied assembler from the core image library of the source statement library system, and condense this library.
- Catalog the assembler obtained through the previous CSERV to the core image library of the source statement library volume.

The user can now perform system generation as described. Figure 9 illustrates the system configuration upon which Example Two (Figure 10) is based. The following steps are keyed to Example Two:

Step 1 Disk-only users receive the system on disk. Disk users with at least one tape unit available receive the system on tape.

Mount the IBM-supplied core image and source statement library volume. Users with tape must also mount a disk pack to which the tape is to be restored.

Before generating a system with at least one tape unit the user should have an initialized disk pack (VTOC on cylinder 199).

- a. If the disk pack has not been initialized, the IBM-supplied volume, a self-loading tape, is capable of initializing the pack (see Figure 10). The DLBL cards used in the following steps must contain the volume serial number appearing in the VOL card of the initialize disk control cards. Any volume serial number used in the EXTENT cards for the following steps must agree with the volume serial number in the VOL card for the initialize disk control card.
- b. If the disk pack has been previously initialized, the initialize disk routine can be bypassed (see Figure 10). Any volume serial number used in the EXTENT cards for the following steps must agree with the volume serial number used when the pack was initialized.

Step 2 After step 1 is completed, the user must restore the system from the self-loading tape to the initialized pack. This step is omitted when a system is received on disk.

Step 3 When the tape has been restored, dial the address of the system residence disk drive into the load unit switches, and IPL to pass control to the DOS supervisor. Then perform a DSERV to display the directories. See Appendix A for the IPL control statements.

Step 4 SSERV (display and punch) all the desired sample problems from the source statement library into cards. Punched output includes the sample problems with BKEND and CATALS cards. Four other books in the source statement library that should be punched out at this time (Z.LINKEDIT, Z.DELETECL, Z.DELETERL, and Z.DELETESL) contain the necessary control statements to selectively linkage edit and delete all IBM components. The sample problem program names, the linkage edit, and the delete book names can be chosen and punched using the DSPCH statement(s). The sample problem program names and the linkage edit and delete book names are shown in Appendix C.

After these sample problems and books have been punched, they can be deleted from the source statement library along with unwanted macros (e.g., those components never to be used).

Step 5 If additional space is needed for workfiles to perform assemblies, (SYS001, SYS002 and SYS003) the user can re-allocate the system to take advantage of the space gained by the deletes from the previous step.

Step 6 The workfiles SYSLNK, SYS001, SYS002, and SYS003 are defined by use of the DLBL and EXTENT cards. These cards must be preceded by the OPTION STDLABEL or OPTION PARSTD card.

Step 7 Perform all necessary assemblies. The assemblies for the supervisor, and IOCS modules should be performed as separate job steps. The user must be careful to keep all assemblies in order.

If the user's operational system is to contain a minimum source statement library with selected macros, they should be obtained through an SSERV. The macros obtained in this step will later be placed on SYSIPT and cataloged to a system source statement library.

Step 8 Disk users without tape must remove the IBM-supplied core image and source statement library pack, and replace it with the IBM-supplied core image and relocatable library pack. The pack removed should be retained for backup.

Users with tape can either replace the core image and source statement library pack, or they can restore the IBM-supplied core image and relocatable library tape to this same initialized disk pack.

Before restoring the tape, the user must take the necessary action to perform or bypass the initialize disk routine.

Step 9 After step 8 is completed, the user must restore the system from the self-loading tape to the initialized pack. This step is omitted when a system is received on disk.

Step 10 Dial the address of the system residence disk drive into the load unit switches, and IPL to pass control to the DOS supervisor.

Step 11 Perform a DSERV to display the directories. Delete all relocatable library components not to be used.

Step 12 Reallocate library sizes, assigning all free space with the exception of linkage editor work files, to the core image library. If room is available at this time, the user can also allocate the small source statement library to contain those macros punched in step 7. Otherwise, this allocation can be done in step 15. The linkage editor work files (SYSLNK and SYS001) are already defined

on this pack. The user need only assign SYSLNK and SYS001 to this drive. (See step 10 in Figure 10.)

- Step 13 Linkage edit and catalog the assembled supervisor (from step 7) to the core image library. Certain key programs must also be linkage edited and cataloged in the same job step with the new supervisor if the SEND address is larger than the one used by the supervisor being replaced. These key programs are IPL, linkage editor, and librarian. The control statements to linkage edit these programs are in the linkage edit deck punched out in step 4. The SSERV and assembler components illustrated in Figure 10, step 13, should be included as part of this job only if the user's operational system is to contain a minimum source statement library.

The new supervisor is not cataloged until a /& statement is read. The user must not attempt any other operations from the time when the supervisor and preceding programs are cataloged and the subsequent IPL.

- Step 14 After these key programs have been cataloged, re-IPL, and set the date (set the clock if the timer feature is present).

Linkage edit and catalog any additional components desired to the core image library. See Appendix C for a complete, list of control cards for all components. The LINKEDIT deck punched out in step 4 contains all of the necessary control statements to linkage edit all components shipped on the system.

Before the next step is performed check the linkage editor listings and make all necessary corrections before deleting the modules from the relocatable library.

- Step 15 If the components deleted in step 11 did not provide adequate space for the final allocation of system libraries, a new allocation can be performed by deleting components previously cataloged to the core image library. More than one deletion and allocation may be required during linkage edit jobs. Users desiring a small source statement library should now allocate space for one.

Catalog the modules assembled in step 7 to the system relocatable library. If your decision was to have a source statement library on this pack, catalog the source statement macros punched in step 7 to the system source statement library.

The user may set new standard labels, re-allocate library sizes, and set automatic condense limits. Backup for the operational system should also be obtained.

INPUT/OUTPUT DEVICE CONFIGURATION FOR EXAMPLE TWO (SEE FIGURE 9)

<u>Device</u>	<u>Channel</u>	<u>Unit</u>	<u>Use</u>
2540R	0	0C	Card Reader (SYSRDR/SYSIPT)
2540P	0	0D	Card Punch (SYSPCH)
1403	0	0E	Printer (SYSLST)
1052	0	1F	Printer-Keyboard (SYSLOG)
2400T7	1	81	Magnetic Tape with data conversion feature
2311	1	90	Disk (SYSRES, SYSLNK, SYS001, SYS002, SYS003)

Example Two: Results of System Generation

When system generation is completed for Example Two (see Figure 10), the operational disk contains COBOL, PL/I, Basic FORTRAN, Tape Sort/Merge and Utilities together with the installation's tailored supervisor, job control, linkage editor, and librarian programs in the core image library. The tape shipped by IBM is retained as a backup tape. The relocatable library contains all those components shipped by IBM except those that were deleted in steps 11 and 15. There is no source statement library on this operational pack. This is a user option, and was indicated as such in the example. Thus, the user may either utilize the source statement library shipped by IBM on the source statement library volume, or he may build a source statement library on the operational pack by allocating space and cataloging his desired macro definitions.

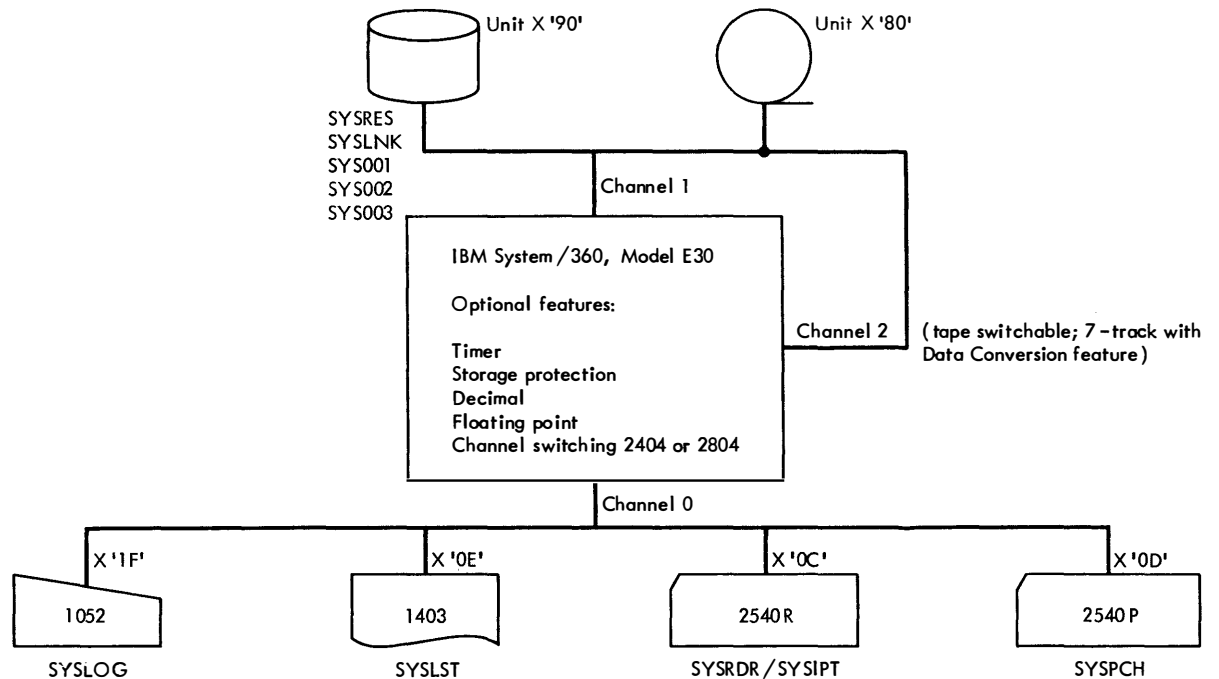

Figure 9. System Configuration for Example Two

IBM System 360 Assembler Coding Form										PAGE OF											
PROGRAM EXAMPLE TWO: ONE DISK DRIVE										CARD ELECTRIC NUMBER											
PROGRAMMER STEP 1a										DATE											
STATEMENT										IDENTIFICATION											
1	Name	8	10	Operation	14	16	Operand	22	30	35	40	45	50	55	Comments	60	65	70	75	Sequence	80
	The user may optionally bypass the initialize routine. However, if initialization is required mount a pack on unit 190. Mount IBM-supplied tape on unit 180 (7-track drive). Place the following cards in the card reader. Dial 180 in the load unit switches and press load. When system enters the wait state press start and EOF on the card reader. Use of multi-part forms is suggested as copies of the linkage editor maps and the supervisor listing will be required by your IBM customer engineer for maintenance purposes.																				
	// LOG																				
	// JOB INTDSK																				
	// DATE 69032																				
	// ASSGN SYSLOG,X'01F',C1																				
	// ASSGN SYSIOPT,X'190',D1																				
	// EXEC																				
	// UID IR,C1																				
	// VTOC STRTADR=(0199000),EXTENT=(9)																				
	VOL11111111																				
	// END																				

IBM System 360 Assembler Coding Form										PAGE OF											
PROGRAM EXAMPLE TWO: ONE DI K DRIVE										CARD ELECTRIC NUMBER											
PROGRAMMER STEP 1b										DATE											
STATEMENT										IDENTIFICATION											
1	Name	8	10	Operation	14	16	Operand	22	30	35	40	45	50	55	Comments	60	65	70	75	Sequence	80
	To bypass initialize disk program on IBM-supplied tape, mount IBM-supplied tape on unit 180 (7-track drive). Mount initialized disk on unit 190 (VTOC on CYL 199). Insert the following control cards in the reader. Dial 180 in load unit switches. Press load key. When system enters wait state, press start and EOF on the card reader. Job is complete when 00C and 4000A messages are logged.																				
	// LOG																				
	// JOB INTDSK																				
	// DATE 69032																				
	// ASSGN SYSLOG,X'01F',C1																				
	// FILES SYSIPT,1																				

Figure 10. Example Two (Part 1 of 12)

IBM		IBM System 360 Assembler Coding Form										PAGE OF																																																																					
PROGRAM	EXAMPLE TWO: ONE DISK DRIVE										CARD ELECTRO NUMBER																																																																						
PROGRAMMER	STEP 2										DATE																																																																						
Name	8	9	10	11	12	13	14	15	16	17	18	19	20	21	22	23	24	25	26	27	28	29	30	31	32	33	34	35	36	37	38	39	40	41	42	43	44	45	46	47	48	49	50	51	52	53	54	55	56	57	58	59	60	61	62	63	64	65	66	67	68	69	70	71	72	73	74	75	76	77	78	79	80								
<p>**** Caution **** Do not rewind unit 180. To load the tape onto disk, place the following cards in the reader. Dial 180 in load switches. Press load. When the system enters the wait state, press start and EOF on card reader. The following message appears on SYSLOG: 4444A. Type in 4 (B) and press INTERRUPT to continue.</p>																																																																																	
//	J	O	B	D	I	S	R	S	T																																																																								
//	D	A	T	E	6	9	0	3	2																																																																								
//	A	S	S	G	N	S	Y	S	'	0	0	,	X	'	1	9	0	'	,	D	1																																																												
//	A	S	S	G	N	S	Y	S	'	L	O	G	,	X	'	0	1	F	'	,	C	1																																																											
//	A	S	S	G	N	S	Y	S	'	L	S	T	,	X	'	0	0	E	'	,	L	1																																																											
//	E	X	E	C																																																																													

IBM		IBM System 360 Assembler Coding Form										PAGE OF																																																																			
PROGRAM	EXAMPLE TWO: ONE DISK DRIVE										CARD ELECTRO NUMBER																																																																				
PROGRAMMER	STEP 3										DATE																																																																				
Name	8	9	10	11	12	13	14	15	16	17	18	19	20	21	22	23	24	25	26	27	28	29	30	31	32	33	34	35	36	37	38	39	40	41	42	43	44	45	46	47	48	49	50	51	52	53	54	55	56	57	58	59	60	61	62	63	64	65	66	67	68	69	70	71	72	73	74	75	76	77	78	79	80						
<p>After the system is loaded onto disk generate the installation system. Dial 190 in load unit switches. Press load key on console. When system enters the wait state, press start and EOF on the card reader. The following cards are in the card reader.</p>																																																																															
ADD	X	'	0	0	C	'	,	2	5	4	0	R																																																																			
ADD	X	'	0	0	D	'	,	2	5	4	0	P																																																																			
ADD	X	'	0	0	E	'	,	1	4	0	3																																																																				
ADD	X	'	0	1	F	'	,	1	0	5	0	A																																																																			
ADD	X	'	1	9	0	'	,	2	3	1	1																																																																				
ADD	X	'	1	8	0	'	,	2	4	0	0	T	7																																																																		

Figure 10. Example Two (Part 2 of 12)

IBM	IBM System 360 Assembler Coding Form										PAGE OF	
PROGRAM	EXAMPLE TWO: ONE DISK DRIVE										PAGE	
PROGRAMMER	STEP 3										CARD ELECTRIC NUMBER	
Name	Operation	Operation	Operation	Operation	Operation	Operation	Operation	Operation	Operation	Operation	Comments	Identification-Sequence
SET	DATE	=02/01/69	CLOCK	=00/00/00								
ASSGN	SYSLOG	X'01F'										
LOG												
ASSGN	SYSRDR	X'00C'										
ASSGN	SYSIPT	X'00C'										
ASSGN	SYSLST	X'00E'										
ASSGN	SYSPCH	X'00D'										
ASSGN	SYS001	X'190'										
ASSGN	SYS002	X'190'										
ASSGN	SYS003	X'190'										
//	JOB	DSERVSLB										
//	EXEC	DSERV										
	DISP	ALL										
//	*											
//	&											

IBM	IBM System 360 Assembler Coding Form										PAGE OF		
PROGRAM	EXAMPLE TWO: ONE DISK DRIVE										PAGE		
PROGRAMMER	STEP 4										CARD ELECTRIC NUMBER		
Name	Operation	Operation	Operation	Operation	Operation	Operation	Operation	Operation	Operation	Operation	Comments	Identification-Sequence	
//	JOB	DELETE											
*	THIS	JOB	PUNCHES	AND	DELETES	SAMPLE	PROGRAMS,	DELETE	BOOKS	AND	THE	LINK	
*	EDIT	BOOK											
*	IT	ALSO	DELETES	PAPER	TAPE	IOCS	MACROS	AND	EMULATOR	MACROS.			
//	EXEC	SSERV									See Appendix C for a list of all names.		
	DISP	Z	ALL										
//	*												
//	PAUSE	REMOVE	SAMPLE	PROGRAM	CARDS	FROM	SYSPCH,	PRESS	EJOB	TO	CONT.		
//	EXEC	MAINT											
	DELET	Z	ALL										
	DELET	A	DTFPT	A	PTMOD								
	DELET	A	EU3CG	A	EU3DK	A	EU3EJ	A	EU3ER	A	EU3FT	A	EU3MS
	DELET	A	EU3OS	A	EU3PH	A	EU3PT	A	EU3RD	A	EU3TP	A	EU3O
//	*												

Figure 10. Example Two (Part 3 of 12)

IBM		IBM System 360 Assembler Coding Form										PAGE 02								
PROGRAM		EXAMPLE TWO: ONE DISK DRIVE <td colspan="2">PAGE</td>										PAGE								
PROGRAMMER		STEP 5										CARD ELECTRO NUMBER								
NAME		OPERATION										IDENTIFICATION SEQUENCE								
1	DLBL	IJSYSRS	'DOS SYSTEM RESIDENCE FILE'	'99/365,SD																
2	EXTENT	SYSRES	,111111,1,n,nnnn,nn9																	
3	EXEC	MAINT																		
4	ALLOC	CL=nn(n),SL=nn(n)																		
5	/*																			
6	/&																			

IBM		IBM System 360 Assembler Coding Form										PAGE 03							
PROGRAM		EXAMPLE TWO: ONE DISK DRIVE										PAGE							
PROGRAMMER		STEP 6										CARD ELECTRO NUMBER							
NAME		OPERATION										IDENTIFICATION SEQUENCE							
1	* SYSRES NOW CONTAINS THE ORIGINAL CORE IMAGE LIBRARY, ORIGINAL SOURCE																		
2	* STATEMENT LIBRARY (LESS DELETED SAMPLE PROBLEM, PAPER TAPE																		
3	* MACROS AND EMULATOR)																		
4	* AT THIS POINT, GENERATE THE TAILORED SUPERVISOR																		
5	// JOB ASSEM																		
6	// OPTION DECK, LIST, LOG, STD LABEL																		
7	DLBL	IJSYS01	'SYSTEM WORK FILE NO. 1'	'99/365,SD															
8	EXTENT	SYS001	,111111,8,n,nnn0,nnn,2																
9	DLBL	IJSYS02	'SYSTEM WORK FILE NO. 2'	'99/365,SD															
10	EXTENT	SYS002	,111111,8,n,nnn3,nnn,5																
11	DLBL	IJSYS03	'SYSTEM WORK FILE NO. 3'	'99/365,SD															
12	EXTENT	SYS003	,111111,8,n,nnn6,nnn,9																

Figure 10. Example Two (Part 4 of 12)

1	Name		Card no.													Comments		Identification	
8	13	14	15	20	21	22	23	24	25	26	27	28	29	30	31	32	33	34	
//	EXEC	ASSEMBLY																	
		SUPVR	SYSTEM=DISK																
		CONFIG	MODEL=30,SP=YES,DEC=YES,FP=YES,TIMER=YES																
		STDJC	LISTX=YES,LINES=46																
		FOPT	IT=BG,PC=YES,OC=YES,TEB=6																
		PIOC	CHANSW=RWTAU,TAPE=7,BMPX=YES																
		IOTAB	IODEV=10,JIB=8,CHANQ=6																
		DVCGEN	CHUN=X'00C',DVCTYP=2540R																
		DVCGEN	CHUN=X'00D',DVCTYP=2540P																
		DVCGEN	CHUN=X'00E',DVCTYP=1403																
		DVCGEN	CHUN=X'01F',DVCTYP=1050A																
		DVCGEN	CHUN=X'190',DVCTYP=2311																
		DVCGEN	CHUN=X'180',DVCTYP=2400T7,CHANSW=YES,MODE=X'90'																

1	Name		Card no.													Comments		Identification	
8	13	14	15	20	21	22	23	24	25	26	27	28	29	30	31	32	33	34	
		ASSGN	SYSRDR,X'00C'																
		ASSGN	SYSIPT,X'00C'																
		ASSGN	SYSPCH,X'00D'																
		ASSGN	SYSLST,X'00E'																
		ASSGN	SYSLOG,X'01F'																
		ASSGN	SYSLNK,X'190'																
		ASSGN	SYS001,X'190'																
		ASSGN	SYS002,X'190'																
		ASSGN	SYS003,X'190'																
		SEND	8192																
		END																	
		/*																	
		/*	CHECK ASSEMBLY LISTINGS FOR ERRORS. IF CORRECT																
		/*	REMOVE ASSEMBLED SUPERVISOR FROM SYSPCH, INSERT IN READER																
		/*	FOLLOWING THE INCLUDE CARD IN STEP 13																
		//&																	

Figure 10. Example Two (Part 5 of 12)

IBM		IBM System 360 Assembler Coding Form		PAGE	OF
PROGRAM	EXAMPLE TWO: ONE DISK DRIVE	REVISION			
PROGRAMMER	STEP 7 (continued)	DATE		CARD ELECTRIC NUMBER	
1	2	3	4	5	6
<p>* AT THIS POINT ASSEMBLE IOCS MODULES TO BE CATALOGED TO THE * RELOCATABLE LIBRARY, MOUNT AND READY A SCRATCH TAPE ON 180. * THE FOLLOWING IS AN EXAMPLE. MODULES SHOULD BE ASSEMBLED ON AN * AS REQUIRED BASIS.</p>					
// PAUSE TO CONTINUE PRESS EOB					
// JOB ASSEM2					
// OPTION DECK, LIST, LOG					
// ASSGN SYSPCH, X'180'					
// EXEC ASSEMBLY					
CDMOD RECFORM=FIXUNB, CONTROL=YES, TYPEFILE=INPUT, DEVICE=2540, X					
SEPASMB=YES					
END					
// *					
// EXEC ASSEMBLY					
MTMOD RECFORM=VARUNB, CKPTREC=YES, WORKA=YES, SEPASMB=YES					
END					
// *					
CLOSE SYSPCH, X'000'					
// &					
// PAUSE					

IBM		IBM System 360 Assembler Coding Form		PAGE	OF
PROGRAM	EXAMPLE TWO: ONE DISK DRIVE	REVISION			
PROGRAMMER	STEP 8a	DATE		CARD ELECTRIC NUMBER	
1	2	3	4	5	6
<p>The user may optionally bypass the initialize routine. However, if initialization is required mount a pack on unit 190. Mount IBM-supplied tape on unit 180 (7-track drive). Place the following cards in the card reader. Dial 180 in the load unit switches and press load. When system enters the wait state press start and EOF on the card reader. Use of multi-part forms is suggested as copies of the linkage editor maps and the supervisor listing will be required by your IBM customer engineer for maintenance purposes.</p>					
// LOG					
// JOB INT DSK					
// DATE 69032					
// ASSGN SYSLOG, X'01F', C1					
// ASSGN SYSOPT, X'190', D1					
// EXEC					
// UID IR, C1					
// VTOC STRTADR=(0199000), EXTENT=(9)					
VOL1111111					
// END					

Figure 10. Example Two (Part 6 of 12)

IBM	IBM System 360 Assembler Coding Form										178-509 Printed in U.S.A.											
PROGRAM	EXAMPLE TWO: ONE DISK DRIVE										PUNCHING INSTRUCTIONS	GRAPHIC PUNCH	PAGE	OF								
PROGRAMMER	STEP 8b										DATE		CARD ELECTRO NUMBER									
1	Name	8	10	Operation	14	16	20	Operand	25	30	35	40	45	50	55	Comments	60	65	70	73	Identification Sequence	80
To bypass initialize disk program on IBM-supplied tape, mount IBM-supplied tape on unit 180 (7-track drive). Mount initialized disk on unit 190 (VTOC on CYL 199). Insert the following control cards in the reader. Dial 180 in load unit switches. Press load key. When system enters wait state, press start and EOF on the card reader. Job is complete when 00C and 4000A messages are logged.																						
// LOG																						
// JOB INTDSK																						
// DATE 69032																						
// ASSGN SYSLOG,X'01F',C1																						
// FILES SYSIPT,1																						

IBM	IBM System 360 Assembler Coding Form										178-509 Printed in U.S.A.											
PROGRAM	EXAMPLE TWO: ONE DISK DRIVE										PUNCHING INSTRUCTIONS	GRAPHIC PUNCH	PAGE	OF								
PROGRAMMER	STEP 9										DATE		CARD ELECTRO NUMBER									
1	Name	8	10	Operation	14	16	20	Operand	25	30	35	40	45	50	55	Comments	60	65	70	73	Identification Sequence	80
**** Caution **** Do not rewind unit 180. To load the tape onto disk, place the following cards in the reader. Dial 180 in load switches. Press load. When the system enters the wait state, press start and EOF on card reader. The following message appears on SYSLOG: 4444A. Type in 4 (E) and press INTERRUPT to continue.																						
// JOB DISRST																						
// DATE 69032																						
// ASSGN SYS000,X'190',D1																						
// ASSGN SYSLOG,X'01F',C1																						
// ASSGN SYSLSL,X'00E',L1																						
// EXEC																						

Figure 10. Example Two (Part 7 of 12)

IBM	IBM System 360 Assembler Coding Form										PAGE OF			
PROGRAM	EXAMPLE TWO: ONE DISK DRIVE										FUNCTION	GRAPHIC	PAGE	OF
PROGRAMMER	STEP 10										DATE	FUNCTION	CARD ELECTRO NUMBER	
Name	8	10	Character	4	16	Character	20	32	44	56	68	80	92	104
After the system is loaded onto disk generate the installation system. Dial 190 in load unit switches. Press load key on console. When system enters the wait state, press start and EOF on the card reader. The following cards are in the card reader.														
ADD	X'	00C'	,	2540R										
ADD	X'	00D'	,	2540P										
ADD	X'	00E'	,	1403										
ADD	X'	01F'	,	1050A										
ADD	X'	190'	,	2311										
ADD	X'	180'	,	2400T7										

IBM	IBM System 360 Assembler Coding Form										PAGE OF			
PROGRAM	EXAMPLE TWO: ONE DISK DRIVE										FUNCTION	GRAPHIC	PAGE	OF
PROGRAMMER	STEP 10										DATE	FUNCTION	CARD ELECTRO NUMBER	
Name	8	10	Character	4	16	Character	20	32	44	56	68	80	92	104
SET	DATE=	02/01/69,	CLOCK=	00/00/00										
ASSGN	SYSL	LOG,	X'	01F'										
LOG														
ASSGN	SYSR	D,R,	X'	00C'										
ASSGN	SYSI	P,T,	X'	00C'										
ASSGN	SYSL	S,T,	X'	00E'										
ASSGN	SYSP	C,H,	X'	00D'										
ASSGN	SYSL	N,K,	X'	190'										
ASSGN	SYSO	01,	X'	190'										

Figure 10. Example Two (Part 8 of 12)

IBM		IBM System 360 Assembler Coding Form										IBM-4000 Printed in U.S.A.												
PROGRAM	EXAMPLE TWO: ONE DISK DRIVE										PUNCHING INSTRUCTIONS	GRAPHIC PUNCH	PAGE	OF										
PROGRAMMER	STEPS 11 and 12										DATE	STATEMENT	CARD ELECTRO NUMBER											
1	Name	8	10	Operation	4	16	20	Operation	25	30	35	40	45	50	55	Comments	60	65	70	75	78	80	Identification Sequence	
	//	JOB	DSERVRLB																					
	//	EXEC	DSERV																					
		DISPLY	ALL																					
	//	*																						
	*	THIS JOB DELETES ALL UNWANTED RELOCATABLE MODULES																						
	//	EXEC	MAINT																					
		DELETR	IJL	ALL																				
		DELETR	IJH	ALL																				
		DELETR	IJKSYSI																					
		RENAMR	IJXSYSI																					
	//	*																						
	//	DLBL	IJSYSRS																					
		EXTENT	SYSRES																					
		EXEC	MAINT																					
		ALLOC	CL	=nn(n)																				
	//	*																						
	//	&																						
	//	PAUSE	PRESS	EOB																				

IBM		IBM System 360 Assembler Coding Form										IBM-4000 Printed in U.S.A.												
PROGRAM	EXAMPLE TWO: ONE DISK DRIVE										PUNCHING INSTRUCTIONS	GRAPHIC PUNCH	PAGE	OF										
PROGRAMMER	STEP 13										DATE	STATEMENT	CARD ELECTRO NUMBER											
1	Name	8	10	Operation	4	16	20	Operation	25	30	35	40	45	50	55	Comments	60	65	70	75	78	80	Identification Sequence	
	Steps 13 and 14 contain the coding for including the IBM components selected for this example. The LINKEDIT book displayed and punched in step 4 contains all the necessary job control statements to linkage edit any of the IBM components shipped on the system. The user is encouraged to use this book to tailor a job stream to include any IBM components desired.																							
	//	JOB	CATAL																					
	//	OPTION	CATAL																					
		ACTION	CLEAR																					
		INCLUDE																						
		Supervisor object deck here.																						
	//	*																						

Figure 10. Example Two (Part 9 of 12)

IBM	IBM System 360 Assembler Coding Form										PAGE 02											
PROGRAM	EXAMPLE TWO: ONE DISK DRIVE										PAGE											
PROGRAMMER	STEP 14 (continued)										CARD ELECTRO NUMBER											
DATE																						
PUNCHING INSTRUCTIONS																						
GRAPHIC PUNCH																						
1	Name	8	10	Operation	14	16	20	Operation	25	30	35	40	45	50	55	Comments	60	65	70	73	Identification - Sequence	80
				INCLUDE	IJWTP											TAPE TO PRINTER UTILITY						
				PHASE	T PPR5, IJWTPCS2, NDAUTO																	
				INCLUDE	IJWLAB																	
				//	LBLTYP TAPE																	
				//	EXEC LNKEDT																	
				INCLUDE	IJWTC											TAPE TO CARD UTILITY						
				PHASE	T PCD5, IJWTC CS2, NDAUTO																	
				INCLUDE	IJWLAB																	
				//	LBLTYP TAPE																	
				//	EXEC LNKEDT																	

IBM	IBM System 360 Assembler Coding Form										PAGE 03											
PROGRAM	EXAMPLE TWO: ONE DISK DRIVE										PAGE											
PROGRAMMER	STEP 14 (continued)										CARD ELECTRO NUMBER											
DATE																						
PUNCHING INSTRUCTIONS																						
GRAPHIC PUNCH																						
1	Name	8	10	Operation	14	16	20	Operation	25	30	35	40	45	50	55	Comments	60	65	70	73	Identification - Sequence	80
				INCLUDE	IJWCT											CARD TO TAPE UTILITY						
				PHASE	CDTP5, IJWCTCS2, NDAUTO																	
				INCLUDE	IJWLAB																	
				//	LBLTYP TAPE																	
				//	EXEC LNKEDT																	
				INCLUDE	IJWCD											CARD TO DISK UTILITY						
				PHASE	CDDK5, IJWCDCS2, NDAUTO																	
				INCLUDE	IJWLAB																	
				//	EXEC LNKEDT																	
				INCLUDE	IJWCP											CARD TO PRINTER/PUNCH UTILITY						
				PHASE	CDPP5, IJWCPCS2, NDAUTO																	
				INCLUDE	IJWLAB																	
				//	EXEC LNKEDT																	

Figure 10. Example Two (Part 11 of 12)

IBM		IBM System 360 Assembler Coding Form										PAGE OF										
PROGRAM: EXAMPLE TWO: ONE DISK DRIVE		DATE:		RUNNING INSTRUCTIONS		GRAPHIC SYMBOLS		PAGE OF		CARD ELECTRO NUMBER												
PROGRAMMER: STEP 14 (continued)		STATEMENT										IDENTIFICATION										
1	Name	8	10	Operation	14	16	20	Operation	24	30	32	40	45	50	55	Comments	60	65	71	73	Identification	80
				INCLUDE	IJWDC											DISK-TO-CARD UTILITY						
				PHASE	OKCD5,IJWDCCS2,NOAUTO																	
				INCLUDE	IJWLAB																	
				//	EXEC LINKEDT																	
				PHASE	TPCP,*,NOAUTO											TAPE COMPARE UTILITY						
				INCLUDE	IJWTCF																	
				INCLUDE	IJJCPD1																	
				INCLUDE	IJWXIT																	
				INCLUDE	IJWTCF																	
				//	LBLTYP TAPE																	
				//	EXEC LINKEDT																	
				/*																		
				//	PAUSE	CHECK LINKEDT LISTINGS FOR ERRORS. IF CORRECT PRESS EOB.																

IBM		IBM System 360 Assembler Coding Form										PAGE OF										
PROGRAM: EXAMPLE TWO: ONE DISK DRIVE		DATE:		RUNNING INSTRUCTIONS		GRAPHIC SYMBOLS		PAGE OF		CARD ELECTRO NUMBER												
PROGRAMMER: STEP 15		STATEMENT										IDENTIFICATION										
1	Name	8	10	Operation	14	16	20	Operation	24	30	32	40	45	50	55	Comments	60	65	71	73	Identification	80
				*	AT THIS POINT, DELETE THE COMPONENT PROGRAMS FROM THE RELOCATABLE																	
				*	LIBRARY: COBOL, PL/I AND FORTRAN OBJECT SUBROUTINES REMAIN IN																	
				*	RELOCATABLE LIBRARY AS WELL AS PREASSEMBLED MODULES.																	
				//	EXEC MAINT																	
				DELETR	IJS.ALL,IJTFO,IJTFO1,IJTFO2,IJTFO3,IJTFO4																	
				DELETR	IJO.ALL,IJW.ALL,IJP.ALL,IJB.ALL,IJX.ALL																	
				CONOS	RL																	
				/*																		
				/&																		
				//	JOB CATAL																	
				*	RELOAD 180 WITH THE TAPE CREATED IN STEP 7.																	
				*	CHECK ASSEMBLY LISTING FOR ERRORS. IF CORRECT,																	
				//	PAUSE TYPE EOB TO CONTINUE																	
				//	ASSGN SYSIPT,X'180'																	
				*	CATALOG MODULES TO RELOCATABLE LIBRARY																	
				//	EXEC MAINT																	
				/*																		
				/&																		
				*	SYSTEM GENERATION COMPLETE																	
				*	THE BASIC SYSGEN IS COMPLETE. THE USER MAY SET NEW STANDARD																	
				*	LABELS, RE-ALLOCATE LIBRARY SIZES, AND SET AUTOMATIC CONDENSE																	
				*	LIMITS IF REQUIRED																	
				*	COPY THE OPERATIONAL PACK TO TAPE FOR BACK-UP.																	
				//	PAUSE EOJ SYSTEM GENERATION																	

Figure 10. Example Two (Part 12 of 12)

IBM 2314 Direct Access Storage Facility

The system is supplied on two magnetic tapes. These two tapes contain DOS in a format suitable for restoring them to one 2316 disk pack.

Example three is one of the many possible methods for generating a system. Figure 11 illustrates the system configuration upon which Example Three (Figure 12) is based. The following steps are keyed to Example Three.

Before generating a system, users should have at least one initialized disk pack (VTOC on cylinder 199).

Step 1 Mount the IBM-supplied magnetic tapes and a disk pack to which the tapes are to be restored.

Before restoring the first tape, the user must take the necessary action to perform or bypass the initialize disk routine.

- a. If the disk pack has not been initialized, the IBM-supplied volume, a self-loading tape, is capable of initializing the packs (see Figure 12). The DLBL cards in the following steps must contain the volume serial number appearing in the VOL card of the initialize disk control cards. Any volume serial number used in the EXTENT cards for the following steps must agree with the volume serial number in the VOL card for the initialize disk control cards.
- b. If the disk pack was previously initialized, the initialize disk routine can be bypassed (see Figure 12). Any volume serial number used in the EXTENT cards for the following steps must agree with the volume serial number used when the packs were initialized.

Step 2 After step 1 is completed, the user must restore the system from the self-loading tapes to the initialized pack.

Step 3 When the tapes are restored, dial the address of the system residence disk drive into the load unit switches, and IPL to pass control to the DOS supervisor. See Appendix A for the IPL control statements.

Step 4 Perform a DSERV to display the directories. Then SSERV (display and punch) all the desired sample problems from the source statement library into cards. Punched output includes the sample problems with BKEND and CATALS cards. Four other books in the source statement library that should be punched out at this time (Z.LINKEDIT, Z.DELETECL, Z.DELETERL, and Z.DELETESL) contain the necessary control statements to selectively linkage edit and delete all IBM components. The sample problem program names, and the linkage edit and the delete book names can be chosen and punched into the DSPCH statement(s). The sample problem program names and the linkage edit and delete book names are shown in Appendix C.

Step 5 Define workfiles for SYSLNK, SYS001, SYS002, and SYS003. The workfiles SYSLNK, SYS001, SYS002, and SYS003 are defined by use of the DIBL and EXTENT cards. These cards must be preceded by the OPTION STDLABEL or OPTION PARSTD card.

Step 6 Perform all necessary assemblies. The assemblies for the supervisor, IOCS modules, and emulators should be performed as separate jobs. For the information required to assemble Emulator Programs, refer to the Emulator Program manual listed in the

Preface. The user must be careful to keep all assemblies in order.

Step 7 Assemble all user-required IOCS modules. By assigning SYSPCH to a tape unit, the IOCS modules can be cataloged to the relocatable library without punching them on cards. The IOCS modules required by COBOL, PL/I, and RPG, as defined in Appendix B, are supplied in the relocatable library by IBM.

Close the tape assigned to SYSPCH and reassign SYSPCH to its permanent assignment by using the CLOSE command. The assembly listings should be checked for errors before proceeding.

Step 8 Linkage edit and catalog the assembled supervisor (object module from step 6) to the core image library. If the SEND address is larger than the one used by the supervisor being replaced, certain key programs must also be linkage edited and cataloged to the core image library in the same job step with the new supervisor. These key programs are IPL, linkage editor, and librarian. The LINKEDIT deck punched out in step 4 contains all the necessary control statements to linkage edit all IBM components shipped on the system. If the SEND address is not exceeded, only the supervisor is cataloged. The new supervisor is not cataloged until a /& statement is read. The user must not attempt any other operation from the time the supervisor and these preceding programs are cataloged until IPL time.

Step 9 Re-IPL and set the date (and clock if the Timer Feature is present).

Linkage edit and catalog any additional components desired to the core image library. See Appendix C for a complete list of control cards for all IBM components to be cataloged. Before the next step is performed, check the linkage editor listings, and make all necessary corrections.

Step 10 Reload the tape that was assigned to SYSPCH in step 7 and assign it to SYSIPT. With this tape the MAINT program catalogs the IOCS modules to the relocatable library by the control card // EXEC MAINT. The user may set new standard labels (OPTION STDLABEL), reallocate library sizes, and set automatic condense limits, if required. Backup for the operational disk can be obtained by copying the operational disk pack to tape by using the copy disk-to-tape utility program.

INPUT/OUTPUT DEVICE CONFIGURATION FOR EXAMPLE THREE (SEE FIGURE 11)

<u>Device</u>	<u>Channel</u>	<u>Unit</u>	<u>Use</u>
2540R	0	0C	Card Reader (SYSRDR, SYSIPT)
2540P	0	0D	Card Punch (SYSPCH)
1403	0	0E	Printer (SYSLST)
1052	0	1F	Printer-Keyboard (SYSLOG)
2314	1	30	Disk (SYSRES, SYSLNK, SYS001, SYS002, SYS003, SYS004)
2400T9	1	80	Magnetic Tape

Example Three: Results of System Generation

When system generation is completed for Example One (see Figure 12), the operational disk of the installation contains: Assembler, Basic FORTRAN, COBOL, RPG, PL/I, and the disk sort/merge programs in its core image library, together with the installation's tailored supervisor, job control, linkage editor, and librarian programs. The tapes shipped by IBM are retained as backup tapes. They are self-loading tapes capable of being restored on disk.

The sample problems are punched out during step 4.

Libraries contain all modules and macro definitions shipped from IBM.

The core image library is built to contain those IBM programs chosen by the user.

At this point, the libraries are condensed, and user IOCS modules are assembled and cataloged to the relocatable library.

When system generation is completed, the sample problems should be run against the operational pack to ensure correct creation of all system programs.

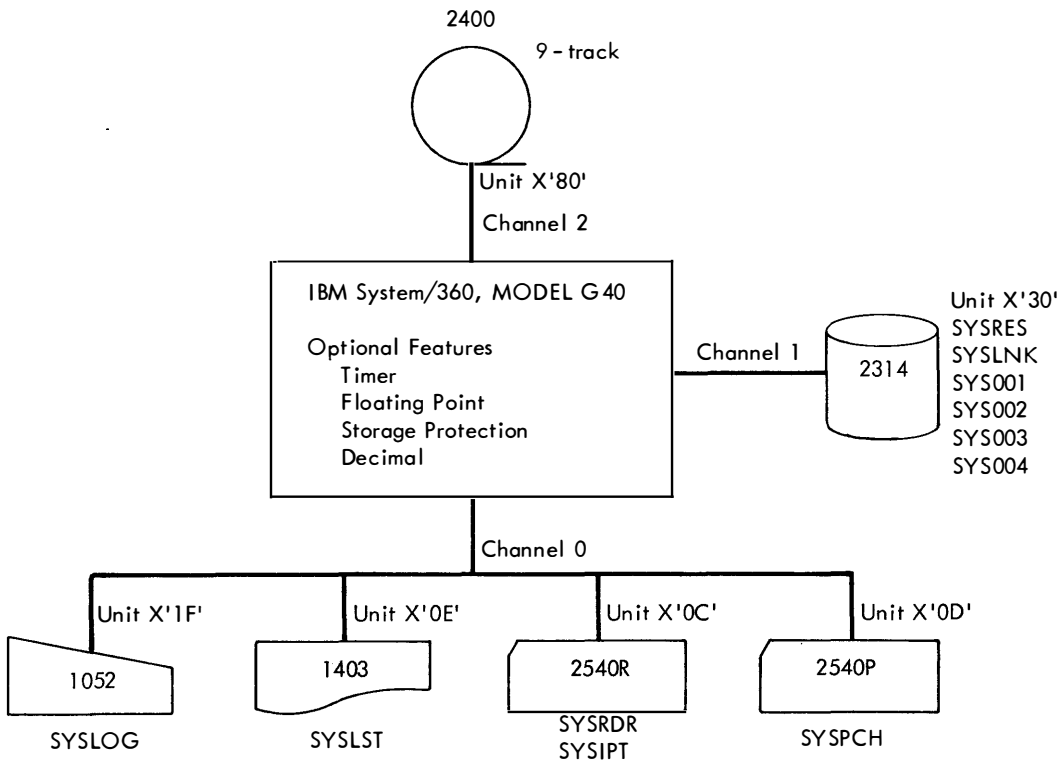

Figure 11. System Configuration for Example Three

IBM	IBM System 360 Assembler Coding Form	PAGE	OF
PROGRAM	EXAMPLE THREE: 2314 DIRECT ACCESS STORAGE		
PROGRAMMER	STEP 1a		CARD ELECTRIC NUMBER
Name	Comments		Identification Reference
<p>The user may optionally bypass the initialized routine. However, if initialization is required mount a pack on unit 130. Mount IBM-supplied tape on unit 180 (9-track drive). Place the following cards in the card reader. Dial 180 in the load unit switches and press load. When system enters the wait state press start and EOF on the card reader. Use of multi-part forms is suggested as copies of the linkage editor maps and the supervisor listing will be required by your IBM customer engineer for maintenance purposes.</p>			
///	JOB	INTDISK	
///	DATE	69032	
///	ASSGN	SYSLOG,X'01F',C1	
///	ASSGN	SYSOPT,X'130',D3	
///	EXEC		
///	UID	IR,C1	
///	VTOC	STRADR=(0199000),EXTENT=(20)	
///	VOL	111111	
///	END		

IBM	IBM System 360 Assembler Coding Form	PAGE	OF
PROGRAM	EXAMPLE THREE: 2314 DIRECT ACCESS STORAGE		
PROGRAMMER	STEP 1b		CARD ELECTRIC NUMBER
Name	Comments		Identification Reference
<p>To bypass initialize disk program on IBM-supplied tape. Mount IBM-supplied tape on unit 130 (9-track drive). Mount initialized disk on unit 130 (VTOC on cyl 199). Insert the following control cards in the reader. Dial 130 in load unit switches. Press load key. When system enters wait state, press start and EOF on the card reader. Job is complete when 00C and 4000A messages are lagged.</p>			
///	JOB	INTDISK	
///	DATE	69032	
///	ASSGN	SYSLOG,X'01F',C1	
///	FILES	SYSIPT,1	

Figure 12. Example Three (Part 1 of 7)

IBM		IBM System 360 Assembler Coding Form										PAGE 01							
PROGRAM	EXAMPLE THREE: 2314 DIRECT ACCESS STORAGE	PLACING INSTRUCTIONS	DATE	DATE	DATE	DATE	DATE	DATE	DATE	DATE	DATE	DATE	CARD ELECTRO NUMBER						
PROGRAMMER	STEP 2																		
Name	8	12	Operation	14	16	20	Operation	22	24	28	32	36	Comments	60	65	71	73	Identification Sequence	80
**** Caution **** Do not rewind unit 180. To load the tape onto disk, place the following cards in the reader. Dial 180 in load switches. Press load. When the system enters the wait state, press start and EOF on card reader. The following message appears on SYSLOG: 4444A. Type in 4 ⑥ and press INTERRUPT to continue.																			
///	JOB	DISRST																	
///	DATE	69032																	
///	ASSGN	SYS000	X	130									D3						
///	ASSGN	SYSLOG	X	01F									C1						
///	ASSGN	SYSLIST	X	00E									L1						
///	EXEC																		

IBM		IBM System 360 Assembler Coding Form										PAGE 01							
PROGRAM	EXAMPLE THREE: 2314 DIRECT ACCESS STORAGE	PLACING INSTRUCTIONS	DATE	DATE	DATE	DATE	DATE	DATE	DATE	DATE	DATE	DATE	CARD ELECTRO NUMBER						
PROGRAMMER	STEP 3																		
Name	8	12	Operation	14	16	20	Operation	22	24	28	32	36	Comments	60	65	71	73	Identification Sequence	80
After the system is loaded onto disk generate the installation system. Dial 130 in load unit switches. Press load key on console. When system enters the wait state, press start on the card reader. The following cards are in the card reader (SYSRDR/SYSIPT).																			
ADD	X	00C											2540R						
ADD	X	00D											2540P						
ADD	X	00E											1403						
ADD	X	01F											1050A						
ADD	X	130											2314						
ADD	X	180											2400T9						
SET	DATE	=02/01/69											CLOCK=00/00/00						
ASSGN	SYSLOG	X	01F																
LOG																			
ASSGN	SYSRDR	X	00C																
ASSGN	SYSIPT	X	00C																
ASSGN	SYSPCH	X	00D																
ASSGN	SYSLIST	X	00E																
ASSGN	SYS001	X	130																
ASSGN	SYS002	X	130																
ASSGN	SYS003	X	130																
ASSGN	SYSLNK	X	130																

Figure 12. Example Three (Part 2 of 7)

IBM		IBM System 360 Assembler Coding Form		PAGE 01														
PROGRAM EXAMPLE THREE: 2314 DIRECT ACCESS STORAGE				CARD ELECTED NUMBER														
PROGRAMMER STEP 4				DATE														
Name	8	10	Operation	14	16	20	25	30	35	40	45	50	55	60	65	70	75	80
//	JOB	DISERV.																
//	EXEC	DISERV.																
	DISPLY	ALL																
//	*																	
//	EXEC	MAINT																
	DELETR	IJL	ALL	,	IJN	ALL												
	DELETR	IJP	ALL	,	IJY	ALL	,	IJZ	ALL									
	DELETR	IJKSYS	A	,	IJKSYS	I												
	RENAMR	IJKSYS	A	,	IJKSYS	A	,	IJKSYS	I	,	IJKSYS	I						
//	*																	
//	&																	

IBM		IBM System 360 Assembler Coding Form		PAGE 01														
PROGRAM EXAMPLE THREE: 2314 DIRECT ACCESS STORAGE				CARD ELECTED NUMBER														
PROGRAMMER STEP 5				DATE														
Name	8	10	Operation	14	16	20	25	30	35	40	45	50	55	60	65	70	75	80
//	JOB	LABEL																
//	OPTIGN	DECK	,	LIST	,	LOG	,	STDLABEL										
//	DLBL	IJSYSLN	,	'SYSTEM	WORK	FILE	NO.	0'	,	99/365	,	SD						
//	EXTENT	SYSLNK	,	nnnnnn	,	1	,	n	,	nnnn	,	nnnn						
//	DLBL	IJSYS01	,	'SYSTEM	WORK	FILE	NO.	1'	,	99/365	,	SD						
//	EXTENT	SYS001	,	nnnnnn	,	1	,	n	,	nnnn	,	nnnn						
//	DLBL	IJSYS02	,	'SYSTEM	WORK	FILE	NO.	2'	,	99/365	,	SD						
//	EXTENT	SYS002	,	nnnnnn	,	1	,	n	,	nnnn	,	nnnn						
//	DLBL	IJSYS03	,	'SYSTEM	WORK	FILE	NO.	3'	,	99/365	,	SD						
//	EXTENT	SYS003	,	nnnnnn	,	1	,	n	,	nnnn	,	nnnn						
//	&																	

Figure 12. Example Three (Part 3 of 7)

Name		Operation		Comments		Identification Sequence	
PROGRAM: EXAMPLE THREE: 2314 DIRECT ACCESS STORAGE							
PAGE: 04							
CARD ELECTRONIC NUMBER:							
PROGRAM: STEP 6							
//	JOB	SUPVR					
//	EXEC	ASSEMBLY					
	SUPVR	SYSTEM=DISK	MPS=YES				
	CONFG	MODEL=40	SP=YES	DEC=YES	FP=YES	TIMER=YES	
	STDJC	LISTX=YES	LINES=46				
	FOPT	IT=BG	PC=YES	OC=YES	CCHAIN=YES	DASDFP=(1,2,2314)	X
		SYSFIL=(2314)	TEB=4				
	PIOCS	TAPE=9	BMPX=YES				
	ALLOC	F1=6K	F2=6K				
	IOTAB	JIB=10	F1PGR=8	F2PGR=8	IODEV=10	BGPGR=10	
	DVCGEN	CHUN=X'00C'	DVCTYP=2540R				
	DVCGEN	CHUN=X'00D'	DVCTYP=2540P				
	DVCGEN	CHUN=X'00E'	DVCTYP=1403				
	DVCGEN	CHUN=X'01F'	DVCTYP=1050A				
	DVCGEN	CHUN=X'130'	DVCTYP=2314				
	DVCGEN	CHUN=X'180'	DVCTYP=2400T9				

Name		Operation		Comments		Identification Sequence	
PROGRAM: EXAMPLE THREE: 2314 DIRECT ACCESS STORAGE							
PAGE: 04							
CARD ELECTRONIC NUMBER:							
PROGRAM: STEP 6 (continued)							
	ASSGN	SYSRDR	X'00C'				
	ASSGN	SYSIPT	X'00C'				
	ASSGN	SYSpch	X'00D'				
	ASSGN	SYSLST	X'00E'				
	ASSGN	SYSLOG	X'01F'				
	ASSGN	SYSLNK	X'130'				
	ASSGN	SYS001	X'130'				
	ASSGN	SYS002	X'130'				
	ASSGN	SYS003	X'130'				
	SEND	10240					
	END						
//	*	CHECK ASSEMBLY LISTING FOR ERRORS. IF CORRECT					
	*	REMOVE ASSEMBLED SUPERVISOR FROM SYSPCH. INSERT IN READER					
	*	FOLLOWING THE INCLUDE CARD OF JOB CATALSUP					
//		PAUSE TO CONTINUE PRESS EOB					
//	&						

Figure 12. Example Three (Part 4 of 7)

IBM		IBM System 360 Assembler Coding Form										PAGE 01														
PROGRAM	EXAMPLE THREE: 2314 DIRECT ACCESS STORAGE	DATE	TIME	DATE	TIME	DATE	TIME	DATE	TIME	DATE	TIME	CARD ELECTRIC NUMBER														
PROGRAMMER	STEP 9 (continued)																									
Name	8	10	Character	4	16	Character	20	32	44	56	68	80	92	104	Comments	112	124	Character	128	140	152	164	176	188	200	
//	JOB	CATAL	CLB																							
*	AT THIS POINT LINKAGE EDIT, COBOL, BASIC, FORTRAN,																									
*	PL/I, RPG, DISK SORT MERGE, 14K ASSEMBLER																									
//	OPTION	CATAL																								
	ACTION CLEAR																									
	INCLUDE	IJSCBD																								
//	EXEC	LNKEDT																								
	INCLUDE	IJSDDDB																								
//	EXEC	LNKEDT																								
	INCLUDE	IJTFO																								
//	EXEC	LNKEDT																								
	INCLUDE	IJXPLID																								
//	EXEC	LNKEDT																								
	INCLUDE	IJRRG																								
//	EXEC	LNKEDT																								
	INCLUDE	IJOSM																								
//	EXEC	LNKEDT																								
	INCLUDE	IJOD32																								
//	EXEC	LNKEDT																								
//	*																									
//	&																									

IBM		IBM System 360 Assembler Coding Form										PAGE 01														
PROGRAM	EXAMPLE THREE: 2314 DIRECT ACCESS STORAGE	DATE	TIME	DATE	TIME	DATE	TIME	DATE	TIME	DATE	TIME	CARD ELECTRIC NUMBER														
PROGRAMMER	STEP 10																									
Name	8	10	Character	4	16	Character	20	32	44	56	68	80	92	104	Comments	112	124	Character	128	140	152	164	176	188	200	
//	JOB	CATAL	R	L	B																					
//	ASSGN	SYS	I	P	T	,	X	'	1	8	0															
*	CATALOG MODULES TO RELOCATABLE LIBRARY																									
//	EXEC	MAINT																								
//	*																									
*	THE FOLLOWING DELETIONS ARE OPTIONAL.																									
//	PAUSE	PLACE	REMAINING	CARDS	IN	READER.	PRESS	EOB	TO	CONTINUE																
//	EXEC	MAINT																								
	Place any desired deletes here.																									
	CONDS	RL	SL																							
//	*																									
//	&																									
*	THE BASIC SYSGEN IS COMPLETE. THE USER MAY SET NEW STANDARD																									
*	LABELS, RE-ALLOCATE LIBRARY SIZES, AND SET AUTOMATIC CONDENSE																									
*	LIMITS IF REQUIRED. COPY THE OPERATIONAL PACK TO TAPE FOR BACK-UP																									
*	USE THE IDENTICAL UTILITY DECK SETUP AS AFTER FIRST SYSGEN JOB.																									
*	THE FINAL CONDENSE OPERATION SUPPLIED THE CURRENT STATUS																									
*	OF THE SYSTEM LIBRARIES.																									
//	PAUSE	EOJ	SYS	GEN	-	-	-	-																		

Figure 12. Example Three (Part 7 of 7)

Maintenance Procedures

The maintenance of Disk Operating System libraries can be performed with the MERGE function of the CORGZ librarian program. The MERGE function allows complete libraries to be merged into one library, or entire components, selected individual phases, modules, or books to be transferred from one existing library to another. When the MERGE function is used, space availability is always a consideration.

Using the MERGE Function of the CORGZ Librarian Program

The MERGE function provides the facility to replace identical entries of a library, or add unique entries to a library. In either case, executing a copy (MERGE) requires that space be available in the library to accommodate the added information.

REPLACING IDENTICAL ENTRIES USING MERGE FUNCTION

When transferring information that is named identically as existing entries of a library, the old entry (phase, module, or book name) is deleted from the library's directory, and the name of the new entry is added to the end of the library's directory. The new entry is the name of the new information. The information itself (phase, module, or book) is added to the end of the library.

ADDING UNIQUE ENTRIES USING MERGE FUNCTION

When uniquely named entries (phase, module, or book name) are transferred to an existing library, the names of the entries are added to the end of the library's directory, and the information itself is added to the end of the library.

General Library Updating Techniques Using the MERGE Function of the CORGZ Librarian Program

The techniques presented here apply to the examples given. They are intended as a guide for the user, and do not necessarily satisfy all user requirements. The method that a user applies to maintain his libraries will depend upon the user's library structure, and his special requirements concerning the maintenance of his library.

COPYING SELECTIVELY TO MERGE LIBRARIES

When there are many more entries desired in an existing library than another, it is usually faster to selectively copy (MERGE) to the library containing the most number of desired entries. Thus, the number of entries

transferred are kept to a minimum to save time. Copying to a library necessarily expands the library. If there is insufficient space in a library to accommodate additional entries, unwanted entries can be deleted, the library condensed, and the new entries then added to the library.

DELETING UNWANTED ENTRIES AND MERGING AN ENTIRE LIBRARY WITH ANOTHER LIBRARY

A second technique is to apply the IBM-supplied DELETERL or DELETESL book to delete all unwanted entries from a library and copy the entire library to another library, thus merging the two libraries. Using this technique requires that the library being copied to contains enough space to accommodate the entire library being copied. If there is insufficient space, the library being copied to can be condensed or reallocated.

COPYING SELECTIVELY, MERGING TWO LIBRARIES TO CREATE A THIRD LIBRARY

If there is insufficient space to accommodate a merge of two libraries, a third library can be created to contain selected entries from the two libraries being merged. This technique eliminates the need for condensing or reallocating an existing library. Note that this technique can be applied by using only two disk drives.

DELETING UNWANTED ENTRIES FROM TWO LIBRARIES AND MERGING BOTH LIBRARIES TO CREATE A THIRD LIBRARY

Another technique for merging two libraries is to delete unwanted entries from the two existing libraries, and merging the two libraries, in their entirety, by copying them to create a third library. Note that this technique can be applied by using only two disk drives.

Conventions for Merge Examples

The following conventions are used in the maintenance examples given here. If a macro definition called *m* is an entry in a library called *L* (*L* being any library and *m* being any macro definition entry in any library *L*) then any macro definition entry *m* in any library *L* can be designated as *Lm*.

Assume that there are two libraries *L* called *A* and *B*, and that the macro definition entries 1, 2, and 3 in library *A* are IBM-supplied, and 8 and 9 are user-defined macro definitions. Further, assume that the user receives a new release of DOS with a source statement library, called library *B*, containing IBM-supplied macro definitions 1, 2, 3, 4, and 5. Thus, library *A* and library *B* can be represented as follows:

Library A-- A1, A2, A3, A8, A9

Library B-- B1, B2, B3, B4, B5

For the libraries defined, macro-definition entries 1, 2, and 3 in library *B* are identical in name to 1, 2 and 3 in library *A*, but a later version or update. Macro definitions 4 and 5 in library *B* are new IBM-supplied macro definitions for the release received, and macro definitions 8 and 9 are

user defined. The structures of the libraries defined here are used in the examples that follow.

Maintenance Examples Using MERGE Function

For each example that follows:

- The macro definitions updated are selected arbitrarily,
- Library A is assumed to reside on disk drive A, and library B on disk drive B,
- Library A is assumed to be the existing user library, and library B the IBM-supplied maintenance update (new release),
- The techniques described can be applied by using only two disk drives.

The following examples illustrate several ways to update an existing library.

EXAMPLE 1A: COPYING SELECTIVELY TO MERGE TWO LIBRARIES

If the majority of the macro definitions desired are in library A, and it is desired to update macro definitions A2 and A3, selectively copy (merge) macro definitions B2 and B3 from IBM-supplied library B to library A. Thus, when there are many more macro definitions in one library than the other, it is faster to selectively copy to the library with the greatest number of entries, if there is enough space in the library being enlarged. If there is not enough space in library A, the unwanted macro definitions A2 and A3 must first be deleted from library A, and library A condensed before the transfer can be attempted.

A representation of the results of selectively copying macro definitions B2 and B3 from library B to library A follows:

Library A-- A1, __, __, A8, A9, B2, B3

Library B-- B1, B2, B3, B4, B5

Note that the macro definitions B2 and B3 are added to the end of the library updated (library A).

EXAMPLE 1B: VARIATION OF SELECTIVE COPYING TO MERGE TWO LIBRARIES

A variation of the technique described in Example 1A demonstrates the capability of transferring in any direction. Thus, if the majority of macro definitions are in library B, and it is desired to update macro definitions A1, A2, and A3, selectively copy macro definitions A8 and A9 from library A to library B.

A representation of selectively copying macro definitions A8 and A9 from library A to library B follows:

Library A-- A1, A2, A3, A8, A9

Library B-- B1, B2, B3, B4, B5, A8, A9

Note that macro definitions A8 and A9 are added to the end of the library updated (library B).

EXAMPLE 2A: DELETING UNWANTED ENTRIES FROM A LIBRARY AND MERGING LIBRARIES BY COPYING ONE TO THE OTHER

Assuming that the majority of macro definitions are in library A, an alternate method of accomplishing an update similar to that described in Example 1A follows.

Delete macro definitions B1, B4, and B5 from library B, and completely copy library B to library A. Thus, the IBM-supplied DELETESL book can delete all unwanted macro definitions from the source statement library, and the library transferred in its entirety.

A representation of the results of deleting macro definitions B1, B4, and B5 from library B, and copying library B follows:

Library A-- A1, __, __, A8, A9, B2, B3

Library B-- __, B2, B3, __, __

Note that library B is added to the end of library A, and that library A in Example 1A is identical to library A in this example.

EXAMPLE 2B: VARIATION OF DELETING UNWANTED ENTRIES FROM A LIBRARY AND COPYING (MERGING) ONE TO THE OTHER

A variation of the technique described in Example 2A that demonstrates the capability of transferring in any direction follows.

Thus, to add macro definitions A8 and A9 to library B, delete macro definitions A1, A2, and A3 in library A and then completely copy library A to library B. Again, the IBM-supplied DELETESL book can delete all unwanted IBM-supplied macro definitions from the source statement library.

A representation of the results of deleting macro definitions A1, A2, and A3 from library A and copying library A to library B follows.

Library A-- __, __, __, A8, A9

Library B-- B1, B2, B3, B4, B5, A8, A9

Note that user macro-definitions A8 and A9 are added to the end of the library being updated (library B), and library B in Example 1B is identical to library B in this example.

EXAMPLE 3: COPYING SELECTIVELY, MERGING TWO LIBRARIES TO CREATE A THIRD LIBRARY

If space is a problem, a third library called C can be created to be a combination of selected macro definitions from both library A and library B. Thus, if the desired macro definitions in library A are A8 and A9 (the user's macro definitions), and B1, B2, and B3 in library B (IBM-supplied), then user macro definitions A8 and A9 can be selectively copied (merged) from library A to library C, and IBM-supplied macro definitions B1, B2, and B3 can be selectively copied (merged) from library B to library C. The advantage of this technique is that the need for a condense or reallocation of an existing library is eliminated, and time is saved. However, the time required to initialize a third disk pack must be taken into consideration. A representation of the results of selectively copying library A and library B (merging) to create library C follows:

Library A-- A1, A2, A3, A8, A9

Library B-- B1, B2, B3, B4, B5

Library C-- B1, B2, B3, A8, A9

Note that library C requires less space than if either library A or library B were merged with each other.

EXAMPLE 4: DELETING UNWANTED ENTRIES FROM TWO LIBRARIES AND MERGING BOTH LIBRARIES TO CREATE A THIRD LIBRARY

A variation of selectively copying from two libraries to form a third library follows.

To retain user macro definitions A8 and A9 in library A, and update IBM-supplied macro definitions A1, A2, and A3 in library A, delete A1, A2, and A3 from library A, and B4 and B5 from library B. Then completely copy (merge) library A and library B to create a third library C.

A representation of the results of deleting unwanted macro definitions from library A and library B, and copying (merging) both libraries to create a third library C follows:

Library A-- __, __, __, A8, A9

Library B-- B1, B2, B3, __, __

Library C-- B1, B2, B3, A8, A9

Note that library C requires less space than if either library A or B were merged with each other. Also note that library C in Example 3 is identical to library C in this example.

Considerations for Merging

The DIBL and EXTENT file definition statements must precede the MERGE control statement. When defining files, use the following rules:

In merging to or from a modified, or duplicate system residence file, the modified or duplicate file name must be IJSYSRS, the logical unit must be SYS002, and the file ID (identification) must be identical to the ID supplied when the file was created.

In merging to a private relocatable library file, the file name must be IJSYSRL, the logical unit must be SYSRLB, and the file ID must be identical to the ID supplied when the file was created.

In copying from a private relocatable library file, the file name must be IJSYSPR, the logical unit must be SYS001, and the file ID must be identical to the ID supplied when the file was created.

In merging to a private source statement library file, the file name must be IJSYSSL, the logical unit must be SYSSLB, and the file ID must be identical to the ID supplied when the file was created.

In copying from a private source statement library file, the file name must be IJSYSPS, the logical unit must be SYS000, and the file ID must be identical to the ID supplied when the file was created. The file name, logical unit, and direction of transfer for each of the MERGE operations is indicated in the Figure 13. Any combination of the indicated operations can be performed in one job step.

File Name Logical unit	IJSYSRS SYSRES	IJSYSRS SYS002	IJSYSRL SYSRLB	IJSYSPR SYS001	IJSYSSL SYSSLB	IJSYSPS SYS000
Merge RES to NRS	from	to				
Merge NRS to RES	to	from				
Merge RES to PRV	from		to		to	
Merge NRS to PRV		from	to		to	
Merge PRV to RES	to			from		from
Merge PRV to NRS		to		from		from
Merge PRV to PRV			to	from	to	from

Figure 13. Merge Operation File Name and Logical Unit Identification

Diagnostic messages for erroneous assignments, file definitions, etc., are provided on SYSLST.

The following is an example of a job set up for the MERGE function. The sections of the job are bracketed and numbered 1 through 8. The explanations that follow the job are keyed to the job sections. The example assumes two disk drives with addresses of 190 and 191 that:

1. the MERGE function of the CORGZ librarian program is on SYSRES which is on 190 by virtue of an IPL
2. SYSRLB and SYSSLB are assigned to 191, SYS000 and SYS001 to 190, and SYS002 to 191.

// JOB EXAMPLE

// ASSGN SYSRLB,X'191'

```

// ASSGN SYSSLB,X'191'
// ASSGN SYS000,X'190'
// ASSGN SYS001,X'190'
// ASSGN SYS002,X'191'
1[// DLBL IJSYSRL,'PRIVATE RL',69/365
  // EXTENT SYSRLB,111111,1,0,1500,10
2[// DLBL IJSYSSL,'PRIVATE SL',69/365
  // EXTENT SYSSLB,111111,1,0,1600,10
3[// DLBL IJSYSR,'PRIVATE RL TEST',69/365
  // EXTENT SYS001,111111,1,0,1300,10
4[// DLBL IJSYSPS,'PRIVATE SL TEST',69/365
  // EXTENT SYS000,111111,1,0,1400,10
5[// DLBL IJSYSRS,'SYSTEM RESIDENCE',69/365
  // EXTENT SYS002,111111,1,0,1,170
// EXEC CORGZ
6[NEWVOL RL=10(2),SL=10(2)
  COPYR ALL
  COPYS ALL
7[MERGE PRV,PRV
  COPYR ALL
  COPYS ALL
8[MERGE NRS,PRV
  COPYR ALL
  COPYS ALL
/*
/ε

```

The following explanations are keyed to the sections of the job:

1. File definition statements for a private relocatable library file which is created and updated.
2. File definition statements for a private source statement library file which is created and updated.
3. File definition statements for a private relocatable library file from which modules are copied.
4. File definition statements for a private source statement library file from which books are copied.
5. File definition statements for a modified, or duplicate system residence file from which modules and books are copied. Note that this file is the old SYSRES (with user programs).
6. Creates private relocatable and source statement libraries on SYSRLB and SYSSLB and copies the relocatable and source statement libraries from the system residence file on SYSRES into them.
7. Merges all modules and books from private relocatable and source statement libraries on SYS001 and SYS000 into the appropriate private libraries created on SYSRLB and SYSSLB.

8. Merges all modules and books from the relocatable and source statement libraries of a modified, or duplicate system residence file on SYS0 into private libraries created on SYSRLB and SYSSLB.

For a more detailed description of the MERGE function see the System Control and System Service manual listed on the front cover.

Disk Operating System Sample Problems

The sample problems provided with the Disk Operating System (DOS) demonstrate to the user, particularly the operator, each component of the programming system. Although the problems are general and illustrative rather than detailed and exhaustive, they nevertheless serve as a minimal test of each user's programming system. The user's programming system is built from the more general system supplied by IBM.

The sample problems are designed to be run on a minimum system configuration including at least one 2311 disk drive (the system residence volume), a card reader/punch, printer, and a 1052 Printer-Keyboard. The minimum background partition storage capacity required for each sample problem is given in Background Partitions Storage Requirements for Disk Operating System IBM-Supplied Programs.

No data is required for any of the sample problems, except RPG, PL/I, Autotest, and multiprogramming. The requirements for each problem are described in the examples that follow.

All sample problems, except those for multiprogramming, are included in the IBM-supplied core image and source statement library volume. The multiprogramming sample problem is prepared by the user. Those sample problems included in the source statement library volume are retrieved as card decks by the SSERV librarian program. Each card deck is either a source program or a set of control cards. Individual decks are preceded by a CATALS card and a BKEND card and followed by a BKEND card. Once the sample problems have been retrieved, they can be deleted from the user's operational system disk during system generation.

Retrieving the Sample Problems

The sample problems are retrieved from the second volume (core image and source statement library volume) during system generation. Although the order for retrieving the problems from the disk is optional, it is recommended that they be retrieved in the order of intended execution. This facilitates the task of preparing the job stream. The following job steps are necessary to retrieve all of the sample problems:

```
// JOB SAMPLPRB
// EXEC SSERV
  DSPCH Z.FO1,Z.CB1,Z.RG1,Z.PL1,Z.AS1
  DSPCH Z.SM1,Z.UTPPR1,Z.AS2,Z.SM2
  DSPCH Z.UTDKPR1,Z.AS3,Z.UTDCPR1
  DSPCH Z.AS4,Z.SM4,Z.UTPPR2
  DSPCH Z.AS5,Z.SM5,Z.UTDKPR2
  DSPCH Z.AS6,Z.SM6,Z.UTDKPR3
  DSPCH Z.MCR1,Z.MCR2,Z.EU3SPRGM,Z.EU4SPRGM
  DSPCH Z.AT1,Z.ORDC,Z.ORJT,Z.VFU1
```

/E

If you do not wish to retrieve a particular problem from the source statement library volume, delete the appropriate operand from the preceding DSPCH statement. All of the sample problems are in the Z sub-library and all of that sub-library can be retrieved with the DSPCH Z.ALL statement.

Card columns 73-80 in each sample problem deck (except RPG) contain an identification number and a sequence number. The identification number for the RPG sample problem deck is punched in columns 75-78. Card columns 1-5 contain the sequence number for RPG. Although these numbers can be used to identify individual sample problems, it is recommended that the cards be machine-interpreted.

Figure 14 shows the arrangement and identification and sequence numbers of each of the sample problem card decks produced by the SSERV librarian program during system generation. These decks are punched in the order in which they are retrieved from the source statement library volume (preferably the intended order of program execution). To prepare each sample problem for execution, the user must:

- Remove all CATALS and BKEND cards shown in Figure 14. If the RPG or PL/I sample problem is retrieved, remove the *END SOURCE DECK/BEGIN INPUT CARDS card from the programs.
- Punch and insert the necessary job control cards for each program to be run, as shown in the examples.

The programs are compiled or assembled, linkage edited, and executed with a minimum of operator intervention.

Cards Retrieved		Card Cols. 73 - 76	Card Cols. 77 - 80
CATALS Z.FO1 BKEND Z.FO1 FORTRAN Source Deck (22 cards) BKEND	} }	FORTRAN Sample Problem \$451	0001 - 0022
CATALS Z.IILFSAMPL BKEND Z.IILFSAMPL FORTRAN Source Deck (22 Cards) BKEND	} }	FORTRAN IV Sample Problem \$479	0001 - 0022
CARALS Z.CB1 BKEND Z.CB1 COBOL Source Deck (81 cards) BKEND	} }	COBOL Sample Problem \$452	0001 - 0081
CATALS Z.RG1 BKEND Z.RG1 RPG Source Deck (45 Cards) * END SOURCE DECK/BEGIN INPUT DATA RPG Data (13 Cards) BKEND	} }	RPG Sample Problem \$460	
CATALS Z.PL1 BKEND Z.PL1 PL/I Source Deck (38 Cards) * END SOURCE DECK/BEGIN INPUT DATA PL/I Data (1 Card) BKEND	} }	PL/I Sample Problem \$464	0001 - 0038
CATALS Z.AS1 BKEND Z.AS1 Assembler Source Deck (23 Cards) BKEND	} }	Assembler Sample Problem 1 (Generate input for Tape Sort/Merge) \$465	0001 - 0023
CATALS Z.SM1 BKEND Z.SM1 S/M Control Cards (6 Cards) BKEND	} }	Sort/Merge Sample Problem (Generate input for Tape - to - Printer Utility) \$400	0001 - 0006
CATALS Z.UTTPR1 BKEND Z.UTTPR1 T - P Control Cards (2 Cards) BKEND	} }	Tape - to - Printer Utility Sample Problem \$452	0001 - 0002
CATALS Z.AS2 BKEND Z.AS2 Assembler Source Deck (23 Cards) BKEND	} }	Assembler Sample Problem 2 (Generate input for Disk Sort/Merge) \$465	0101 - 0123
CATALS Z.SM2 BKEND Z.SM2 S/M Control Cards (6 Cards) BKEND	} }	Disk Sort/Merge Sample Problem (Generate input for Disk - to - Printer Utility) \$450	0001 - 0006
CATALS Z.UTDKPR1 BKEND Z.UTDKPR1 D - P Control Cards (2 Cards) BKEND	} }	Disk - to - Printer Utility Sample Problem \$461	0001 - 0002

Figure 14. Sample Problem Card Decks Retrieved from IBM-Supplied Core Image and Source Statement Library Volumes (Part 1 of 3)

Cards Retrieved		Card Cols. 73 - 76	Card Cols. 77 - 80
CATALS Z.AS3 BKEND Z.AS3 Assembler Source Deck (23 Cards) BKEND	} Assembler Sample Problem 3 (Generate input for Data Cell-to-Printer Utility)	\$465	0201 - 0223
CATALS Z.UTDCPR1 BKEND Z.UTDCPR1 DC - P Control Cards (2 Cards) BKEND	} Data Cell-to-Printer Utility Sample Problem	\$463	0001 - 0002
CATALS Z.AS4 BKEND Z.AS4 Assembler Source Deck (23 Cards) BKEND	} Assembler Sample Problem 4 (Generate input for Tape and Disk Sort/Merge)	\$465	0402 - 0423
CATALS Z.SM4 BKEND Z.SM4 S/M Control Cards (6 Cards) BKEND	} Tape and Disk Sort/Merge 2400 Sample Problem (Generate input for Tape-to-Printer Utility)	\$483	0001 - 0006
CATALS Z.UTTPR2 BKEND Z.UTTPR2 T - P Control Cards (2 Cards) BKEND	} Tape-to-Printer Utility Sample Problem	\$462	0101 - 0102
CATALS Z.AS5 BKEND Z.AS5 Assembler Source Deck (23 Cards) BKEND	} Assembler Sample Problem 5 (Generate input for Tape and Disk Sort/Merge)	\$465	0502 - 0523
CATALS Z.SM5 BKEND Z.SM5 S/M Control Cards (6 Cards) BKEND	} Tape and Disk Sort/Merge 2311 Sample Problem (Generate input for Disk-to-Printer Utility)	\$483	0101 - 0106
CATALS Z.UTDKPR2 BKEND Z.UTDKPR2 D - P Control Cards (2 Cards) BKEND	} Disk-to-Printer Utility Sample Problem	\$461	0101 - 0102
CATALS Z.AS6 BKEND Z.AS6 Assembler Source Deck (23 Cards) BKEND	} Assembler Sample Problem 6 (Generate input for Tape and Disk Sort/Merge)	\$465	0602 - 0623
CATALS Z.SM6 BKEND Z.SM6 S/M Control Cards (6 Cards) BKEND	} Tape and Disk Sort/Merge 2314 Sample Problem (Generate input for Disk-to-Printer Utility)	\$483	0201 - 0206
CATALS Z.UTDKPR3 BKEND Z.UTDKPR3 D - P Control Cards (2 Cards) BKEND	} Disk-to-Printer Utility Sample Problem	\$461	0201 - 0202
CATALS Z.AT1 BKEND Z.AT1 Autotest Source Deck (27 Cards) Autotest Data Deck (5 Cards) BKEND	} Autotest Sample Problem	\$459	0001 - 0027

Figure 14. Sample Problem Card Decks Retrieved from IBM-Supplied Core Image and Source Statement Library Volumes (Part 2 of 3)

Cards Retrieved		Card Cols. 73 - 76	Card Cols. 77 - 80
CATALS Z.VFU1 BKEND Z.VFU1 VFU1 Source Deck (65 Cards) BKEND	} Vocabulary File Utility Sample Problem		Refer to the Vocabulary File Utility Program publication listed on the front cover of this manual.
CATALS Z.MCR1 BKEND Z.MCR1 MCR1 Source Deck (71 Cards) BKEND	} Magnetic Character Recognition Devices (1412/1419)	\$477	0001 - 0071
CATALS Z.MCR2 BKEND Z.MCR2 MCR2 Source Deck (115 Cards) BKEND		\$477	0001 - 0115
CATALS Z.ORDC BKEND Z.ORDC Optical Reader Source Deck (179 Cards) BKEND	} 1287 Sample Problem Document Mode	\$478	0001 - 9179
CATALS Z.ORJT BKEND Z.ORJT Source Deck (81 Cards) BKEND	} 1285/1287 Sample Problem for Journal Tape	\$478	1001 - 1081
CATALS Z.EU3SPRGM BKEND Z.EU3SPRGM EU 1400 object decks and source decks BKEND	} 1401/1440/1460 Emulator Programs for IBM Model 2025/2030		
CATALS Z.EU4SPRGM BKEND Z.EU4SPRGM EU 1400 object decks and source decks BKEND		} 1401/1440/1460 Emulator Programs for IBM Model 2040	

Figure 14. Sample Problem Card Decks Retrieved from IBM-Supplied Core Image and Source Statement Library Volumes (Part 3 of 3)

The sample problems can be run as separate jobs; but, when possible should be run as successive job steps within an operating system environment. A PAUSE card placed at the end of each sample problem to be run in successive job steps allows the operator to make any necessary changes in device assignments. The order for running the sample problems is not completely arbitrary. The assembler, sort/merge, and utility programs should be run consecutively; the output of one program becomes the input to the next program. The FORTRAN, Basic FORTRAN COBOL, PL/I, VFU1, MICR, OCR, and RPG sample problems can either precede or follow the other programs. The sample problems for Autotest and multiprogramming should be run last when the programs are run as successive job steps.

Physical and Logical I/O Assignments

It is assumed that the user has made assignments for these logical I/O functions:

```
SYSLOG   SYSPCH   SYS001
SYSRDR   SYSLST   SYS002
SYSIPT   SYSLNK   SYS003
```

The preceding assignments are for the background problem program area only. The assignments necessary for the multiprogramming sample problem are included in the input test data for that problem.

Unique disk extents must be assigned initially to SYSLNK, SYS001, SYS002, and SYS003.

These extents can be assigned to the system residence pack as follows:

```
SYSLNK
  // XTENT 1,0,000166000,000170009,'111111',SYSLNK

SYS001
  // XTENT 128,0,000171000,000198002,'111111',SYS001

SYS002
  // XTENT 128,0,000171003,000198006,'111111',SYS002

SYS003
  // XTENT 128,0,000171007,000198009,'111111',SYS003
```

If standard assignments are missing, the necessary ASSGN cards should be inserted at the beginning of the job stream. After each job step of a sample problem, certain additional logical I/O assignments or reassignments may be required. Examples of such reassignments are shown in Figures 15 and 16. When reassignments are necessary, the user must furnish:

- The channel and unit number (X'cuu') for each tape or disk extent.
- The proper disk pack serial number and data cell volume number in all DLAB and XTENT cards.

Tape, Disk, and Data Cell Configurations

In addition to the minimum system configuration, three tape drives are required to run the Tape Sort/Merge sample problem, and five tape drives are required to run the Tape and Disk Sort/Merge sample problem (2400 application). A 2314 direct access storage facility is required to run the Tape and Disk Sort/Merge sample problem (2314 application). For installations with 7-track drives, convert feature OFF and translate ON (X'B8' as third operand of ASSGN) must be specified. Where 9-track tape drives are used, the third operand (X'B8') can be omitted. The logical I/O assignments for tape are shown in Figure 15 and those for disk and data cell are shown in Figure 16.

In addition to checking the proper function of each sample problem, the programs also test job control and linkage editor functions. They are helpful in verifying the correct generation of the user's operational system. The main purposes of the sample problems, however, are demonstration and instruction.

A listing of the source program and job control cards is written on SYSLST for each problem. If LOG is keyed into the 1052 Printer-Keyboard at the beginning of the job, a listing of all job control cards and operator messages is written on SYSLOG (Figures 17, 18, 19, and 20). Detailed setup procedures, including job control cards, are given for each sample problem.

Note that the SYSLOG output for the 1401/1440/1460 Emulator Programs can be found in the Emulator Program manual listed in the Preface.

Sample Problem:	Disk Extent No. 1	Tape Drive No. 1 ¹	Tape Drive No. 2 ¹	Tape Drive No. 3 ¹	Tape Drive No. 4	Tape Drive No. 5
Tape Sort/Merge Execute	SYSRES	SYS004	SYS001 ² SYS003 ³	SYS002 ² SYS005 ³		
Tape and Disk Sort/Merge (2400 Application)	SYSRES	SYS001	SYS002	SYS003	SYS004	SYS005
Tape -to -Printer Utility Execute	SYSRES	-----	SYS004	-----		

1. Tape drive number refers to X'cuu' operand in ASSGN card.

2. If a 7-track tape drive is used, the third operand (X'B8') is required to turn byte convert off.

3. For Tape Sort/Merge, SYS001 and SYS003 must be assigned to the same tape drive, as must SYS002 and SYS005.

Figure 15. Sequence of Logical I/O Assignments for Tape Sort/Merge and Tape-to-Printer Utility Sample Problems

Sample Problem	Disk Extent No. 1	Disk Extent No. 2	Disk Extent No. 3	Disk Extent No. 4
FORTRAN or Basic FORTRAN:				
Compile	SYSLNK	SYS001	SYS002**	-----
Link Edit	SYSLNK	SYS001	-----	-----
Execute	-----	-----	-----	-----
COBOL, RPG, Assembler:				
Compile	SYSLNK	SYS001	SYS002	SYS003
Link Edit	SYSLNK	SYS001	-----	-----
Execute	-----	-----	-----	-----
AUTOTEST:				
Assemble	SYSLNK	SYS001	SYS002	SYS003
Link Edit	SYSLNK	SYS001	-----	-----
Execute	SYSLNK*	-----	-----	-----
Disk Sort/Merge Execute	SYS002	SYS004	-----	-----
Tape and Disk Sort/Merge (2311 Application)	SYS001	SYS002	SYS003	-----
Tape and Disk Sort/Merge (2314 Application)	SYS001	SYS002	SYS003	-----
Disk -to -Printer Utility Execute	SYS004	SYS005	-----	-----
Data Cell -to -Printer Utility Execute	SYS004	-----	-----	-----
1285, 1287, 1412/1419:				
Assemble	SYSLNK	SYS001	SYS002	SYS003
Link Edit	SYSLNK	SYS001	-----	-----
Execute	-----	-----	-----	-----

* This is the Autotest work file (IJSYSAT).

** FORTRAN IV only.

Figure 16. Sequence of Logical I/O Assignments for Disk/Data-Cell Sample Problems

```

// JOB FORTRAN
EOJ FORTRAN
// JOB FORTRAN IV
EOJ FORTRAN4
// JOB COBOL
EOJ COBOL
// JOB RPG
EOJ RPG
// JOB PL/I
EOJ PL/I
// JOB ASSEMBLE
// PAUSE ASSGN SYS002 TO A 9 TRACK TAPE DRIVE
EOJ ASSEMBLE
// JOB SORT
// PAUSE ASSGN SYS002 TO SAME TAPE DRIVE AS IN PREVIOUS JOB
// PAUSE ASSGN SYS001, SYS003, SYS004, SYS005 TO DIFF TAPES
EOJ SORT
// JOB TPRR
// PAUSE ASSGN SYS004 TO SYS001 OF PREVIOUS JOB
// PAUSE ASSGN SYS005 TO THE PRINTER
8001D IS IT EOF
EOJ TPRR
// JOB ASSEMBLE
// PAUSE ASSGN SYS002 TO SCRATCH PACK
EOJ ASSEMBLE
// JOB DSORT
// PAUSE ASSGN SYS002 AND SYS004 TO SCRATCH PACK
EOJ DSORT
// JOB DKPR
// PAUSE ASSGN SYS004 TO SCRATCH PACK
// PAUSE ASSGN SYS005 TO THE PRINTER
EOJ DKPR
// JOB ASSEMBLE
// PAUSE ASSGN SYS004 TO DATA CELL
// PAUSE MOUNT CELL nnnnnn ON STATION 3
EOJ ASSEMBLE
// JOB DCPR
// PAUSE ASSGN SYS004 TO DATA CELL
// PAUSE ASSGN SYS005 TO THE PRINTER
EOJ DCPR
BG // JOB ASSEMBLY SAMPLE 4
BG // PAUSE ASSGN SYS002 TO A 9 TRACK TAPE DRIVE
BG
BG EOJ ASSEMBLY
BG // JOB SORT 2400
BG // PAUSE ASSGN SYS002 TO SAME DRIVE AS PREVIOUS JOB
BG
BG // PAUSE ASSGN SYS001, SYS003, SYS004, SYS005 TO DIFF TAPES
BG
BG 7905I RCD IN 0002000, OUT 0002000, ESTIMATED 0000000
BG 7101I END SCRT PH
BG 7905I RCD IN 0002000, OUT 0002000, ESTIMATED 0000000
BG 7201I END MERGE PH

```

Figure 17. SYSLOG Output for all Sample Problems Except Multiprogramming and Vocabulary File Utility Problems (Part 1 of 3)

```

|BG 7905I RCD IN 0002000, OUT 0002000, ESTIMATED 0000000
|BG 7302I EOJ
|BG EOJ SORT
|BG // JOB TPPR 2400 TO PRINTER
|BG // PAUSE ASSGN SYS004 TO SYS001 OF PREVIOUS JOB
|BG
|BG // PAUSE ASSGN SYS005 TO THE PRINTER
|BG
|BG 8001D IS IT EOF
|Y
|BG EOJ TPPR
|BG 1C00A ATTN. 0 0C.
|BG
|BG // JOB ASSEMBLY SAMPLE 5
|BG // PAUSE ASSGN SYS002 TO SCRATCH PACK
|BG
|BG EOJ ASSEMBLY
|BG // JOB SORT 2311
|BG // PAUSE ASSGN SYS001,SYS002,SYS003 TO SCRATCH PACK
|BG
|BG 7905I RCD IN 0002000, OUT 0002000, ESTIMATED 0002000
|BG 7101I END SORT PH
|BG 7905I RCD IN 0002000, OUT 0002000, ESTIMATED 0002000
|BG 7201I END MERGE PH
|BG 7905I RCD IN 0002000, OUT 0002000, ESTIMATED 0002000
|BG 7302I EOJ
|BG EOJ SORT
|BG // JOB DKPR 2311 TO PRINTER
|BG // PAUSE ASSGN SYS004 TO SCRATCH PACK
|BG
|BG // PAUSE ASSGN SYS005 TO THE PRINTER
|BG
|BG 1C00A ATTN. 0 0C.
|BG
|BG // JOB ASSEMBLY SAMPLE 6
|BG // PAUSE ASSGN SYS002 TO SCRATCH PACK
|BG
|BG EOJ ASSEMBLY
|BG // JOB SORT 2314
|BG // PAUSE ASSGN SYS001,SYS002,SYS003 TO SCRATCH PACK
|BG
|BG 7905I RCD IN 0003000, OUT 0003000, ESTIMATED 0003000
|BG 7101I END SORT PH
|BG 7905I RCD IN 0003000, OUT 0003000, ESTIMATED 0003000
|BG 7201I END MERGE PH
|BG 7905I RCD IN 0003000, OUT 0003000, ESTIMATED 0003000
|BG 7302I EOJ
|BG EOJ SORT
|BG // JOB DKPR 2314 TO PRINTER
|BG // PAUSE ASSGN SYS004 TO SCRATCH PACK
|BG
|BG // PAUSE ASSGN SYS005 TO THE PRINTER
|BG
|BG 1C00A ATTN. 0 0C.
|BG

```

Figure 17. SYSLOG Output for All Sample Problems Except Multiprogramming and Vocabulary File Utility Problems (Part 2 of 3)

```

// JOB AUTOTEST
EOJ AUTOTEST
BG // JOB MCR SAMPLE PROBLEMS
BG // PAUSE   END OF MCR1 SAMPLE PROBLEM
BG
BG INTERVENTION REQUIRED ON FILE2
BG EOJ MCR
BG // PAUSE   END OF MCR SAMPLE PROBLEMS
BG
// JOB OPTICAL READER SAMPLE PROBLEM
EOJ OPTICAL
// PAUSE END OF OPTICAL READER SAMPLE PROBLEM
Note: If a multiprogramming system, the message will be preceded by
      the appropriate prefix (BG, F1, F2 or AR).

```

- Figure 17. SYSLOG Output for All Sample Problems except Multiprogramming and Vocabulary File Utility Problems (Part 3 of 3)

The SYSLOG output reproduces much of the SYSLOG output. In addition, SYSLOG displays the source programs, storage maps, sort/merge and utility program control cards, problem results, and other information. If SYSLOG is a 1403 Printer equipped with the Universal Character Set (UCS) feature, see UCS command in the Disk Operating System Operating Guide. If this specification is not made, the issuance of a control command by job control causes a command reject, resulting in job cancellation.

```

BG // JOB CATALOG SAMPLE FOREGROUND/BACKGROUND PROGRAM
BG EOJ CATALOG

BG // JOB EXECUTE SAMPLE FOREGROUND/BACKGROUND PROGRAM
BG // PAUSE CARD READER END-OF-FILE SIGNALS END OF CARD INPUT
BG
BG 0P08A   INTERV REQ SYSRDR=00C
          CCSW=021000224002000000 SNS=400000000000 CCB=002220
BG EOJ EXECUTE
BG // PAUSE REFER TO PRINTER FOR ADDITIONAL INSTRUCTIONS
BG assgn sysrdr,ua
BG assgn sysipt,ua
BG assgn syslst,ua
BG stop
AR 1I60A   READY FOR COMMUNICATIONS.
AR start f1
F1 assgn  ~/s001,x'00c'
F1 assgn  sys0^ ,x'00e'
F1 exec cardprnt
F1 0S10I   PROGRAM CARDPRT COMPLETED

```

Figure 18. SYSLOG Output for Multiprogramming Sample Problem

Any Store

12345678 L

Month	Day
-------	-----

S NAME
 O ADDRESS
 I CITY-STATE
 T
 O

DESCRIPTION	QUANTITY	ITEM NUMBER	SERVICE NO.	CODE	AMOUNT
	05	24680	357	98	2500
	01	36925	468	10	498
	02	13579	205	24	349
	01	72546	763	63	129
	03	56384	920	57	147
	01	42679	431	76	995
	04	66392	117	33	3960
	7				SUB TOTAL 8578
					Cash Charge COD Layaway SALES TAX 150
	13579				TOTAL 8728
					Sold by Auth. No. Void
					FORMAT 0
					021057
					Delivery Date

Figure 19. Optical Reader Sample Input Document for Document Mode Processing

012	3456	789C
123	4567	890S
234	5678	901T
345	6789	012N
456	7890	123S
567	8901	234X
678	9012	345C
789	0123	456T
890	1234	567Z
901	2345	678/
012	3456	789C
123	4567	890S
234	5678	901T
345	6789	012N
456	7890	123S
567	8901	234X
678	9012	345C
789	0123	456T
890	1234	567Z
901	2345	678/
012	3456	789C
123	4567	890S
234	5678	901T
345	6789	012N
456	7890	123S
567	8901	234X
678	9012	345C
789	0123	456T
890	1234	567Z
901	2345	678/

Figure 20. Optical Reader Sample Input for Journal Tape Mode Processing

Examples of Sample Problem Execution and Output

Basic FORTRAN

Program Name is Z.F01. The Basic FORTRAN sample problem generates all prime numbers between 0 and 1000. To execute the Basic FORTRAN sample problem the following job control cards are needed:

```
// JOB FORTRAN SAMPLE
// OPTION LINK,LIST,LOG
// EXEC FORTRAN
    Basic FORTRAN SOURCE DECK (22 cards)
/*
```

```
// EXEC LNKEDT
// EXEC
/ &
```

SYSLOG output is shown in Figure 17.

The following list summarizes the SYSLST output shown in Figure 21:

- Job control cards
- Source program listing
- Object program storage map
- Linkage editor storage map
- List of prime numbers generated by the program

```
// JOB FORTRAN SAMPLE
// OPTION LINK,LIST,LUG
// EXEC FORTRAN

DISK OPERATING SYSTEM/360 FORTRAN 360N-FO-451 30

C PRIME NUMBER PROBLEM $4510001
100 WRITE (3,8) $4510002
8 FORMAT (52H FOLLOWING IS A LIST OF PRIME NUMBERS FROM 1 TO 1000/ $4510003
/19X,1H1/19X,1H2/19X,1H3) $4510004
101 I=5 $4510005
3 A=I $4510006
102 A=SQRT(A) $4510007
103 J=A $4510008
104 DO 1 K=3,J,2 $4510009
105 L=I/K $4510010
106 IF(L*K-I)1,2,4 $4510011
1 CONTINUE $4510012
107 WRITE (3,5)I $4510013
5 FORMAT (120) $4510014
2 I=I+2 $4510015
108 IF(1000-I)7,4,3 $4510016
4 WRITE (3,9) $4510017
9 FORMAT (14H PROGRAM ERROR) $4510018
7 WRITE (3,6) $4510019
6 FORMAT (31H THIS IS THE END OF THE PROGRAM) $4510020
109 STOP $4510021
END $4510022

01/01/68 FORTMAIN 0002

SCALARS
SYMBOL LOCATION SYMBOL LOCATION SYMBOL LOCATION SYMBOL LOCATION
I C06C A 0070 J 0074 K 0078 L 007C

CALLED SUBROUTINES
IJTAPST IJTACOM IJTSSWT SQRT

LABEL LOCATION LABEL LOCATION LABEL LOCATION LABEL LOCATION LABEL LOCATION
C01GC 0078 00008 0088 00101 0008 00003 00E0 00102 0100
00103 010E 00104 012C 00105 0134 00106 0144 00001 015E
00107 0172 00005 0190 00002 019A 00108 01A6 00004 018C
00009 010C 00007 01E8 00006 01FC 00109 0226
COMPILATION COMPLETE AMOUNT OF COMMON 000000 AMOUNT OF CORE 000696 ADDRESS BASE TABLE 0200

// EXEC LNKEDT
```

Figure 21. SYSLST Output for Basic FORTRAN Sample Problems (Part 1 of 2)

```

JOB FORTRAN                DISK LINKAGE EDITOR DIAGNOSTIC OF INPUT
ACTION TAKEN      MAP
LIST  AUTOLINK    IJTACOM
LIST  AUTOLINK    IJTACOM
LIST  AUTOLINK    IJTAPST
LIST  AUTOLINK    IJTFIOS
LIST  AUTOLINK    IJTSSQT
LIST  ENTRY

-----

01/01/68  PHASE XFR-AD  LOCORE  HICORE  DSK-AD  ESD TYPE  LABEL      LOADED  REL-FR
          PHASE*** 002000  002000  C0429F  15 9 1  CSECT     FORTMAIN  002000  002000
                                     CSECT     IJTAPST  003510  003510
                                     CSECT     IJTACOM  002288  002288
                                     ENTRY     IJTSAVE  002820
                                     CSECT     IJTSSQT  0041F8  0041F8
                                     ENTRY     SQRT    0041FE
                                     CSECT     IJTACOM  002880  002880
                                     * ENTRY  FCVFI  002880
                                     * ENTRY  FCVFO  002884
                                     * ENTRY  FCVEI  002888
                                     * ENTRY  FCVEO  00288C
                                     * ENTRY  FCVII  002890
                                     * ENTRY  FCVIO  002894
                                     * ENTRY  FCVDI  002D3E
                                     * ENTRY  FCVDO  002F46
                                     CSECT     IJTFIOS  0035A0  0035A0
                                     ENTRY     UNITABE 003F86
                                     * ENTRY  DGI0XXE 003D8A
                                     * ENTRY  GETUNTE 00396A
                                     * ENTRY  QPEMUNE 003988
                                     * ENTRY  SETLGUE 003C26
                                     * ENTRY  CCHNDIE 003F58
                                     * ENTRY  DSKMTME 003E60
                                     * ENTRY  ASNBUFE 003FF4
                                     * ENTRY  FILTAGE 003EE8
                                     * ENTRY  BUFINNT 004142
                                     * ENTRY  NRFSWE  003D88
                                     * ENTRY  CLOSUNE  003856

-----

// EXEC
FOLLOWING IS A LIST OF PRIME NUMBERS FROM 1 TO 1000
  1
  2
  3
  5
  7
 11

          977
          983
          991
          997
THIS IS THE END OF THE PROGRAM

-----

EOJ FORTRAN

```

Figure 21. SYSLST Output for Basic FORTRAN Sample Problems (Part 2 of 2)

FORTRAN

Program Name is Z.IIFSAMPL. This sample problem generates all prime numbers between 2 and 1000. To execute it, the following job control statements are needed:

```

// JOB FORTRAN4 SAMPLE
// OPTION LINK,LIST,LOG
// EXEC FFORTAN

```

```
FORTRAN IV SOURCE DECK (22 cards)
/*
// EXEC LNKEDT
// EXEC
/*
```

SYSLOG output is shown in Figure 17.

The following list summarizes the SYSLST output shown in Figure 22.

- Job control cards
- Source program listing
- Object program storage map
- Linkage editor storage map
- List of prime numbers generated by the program

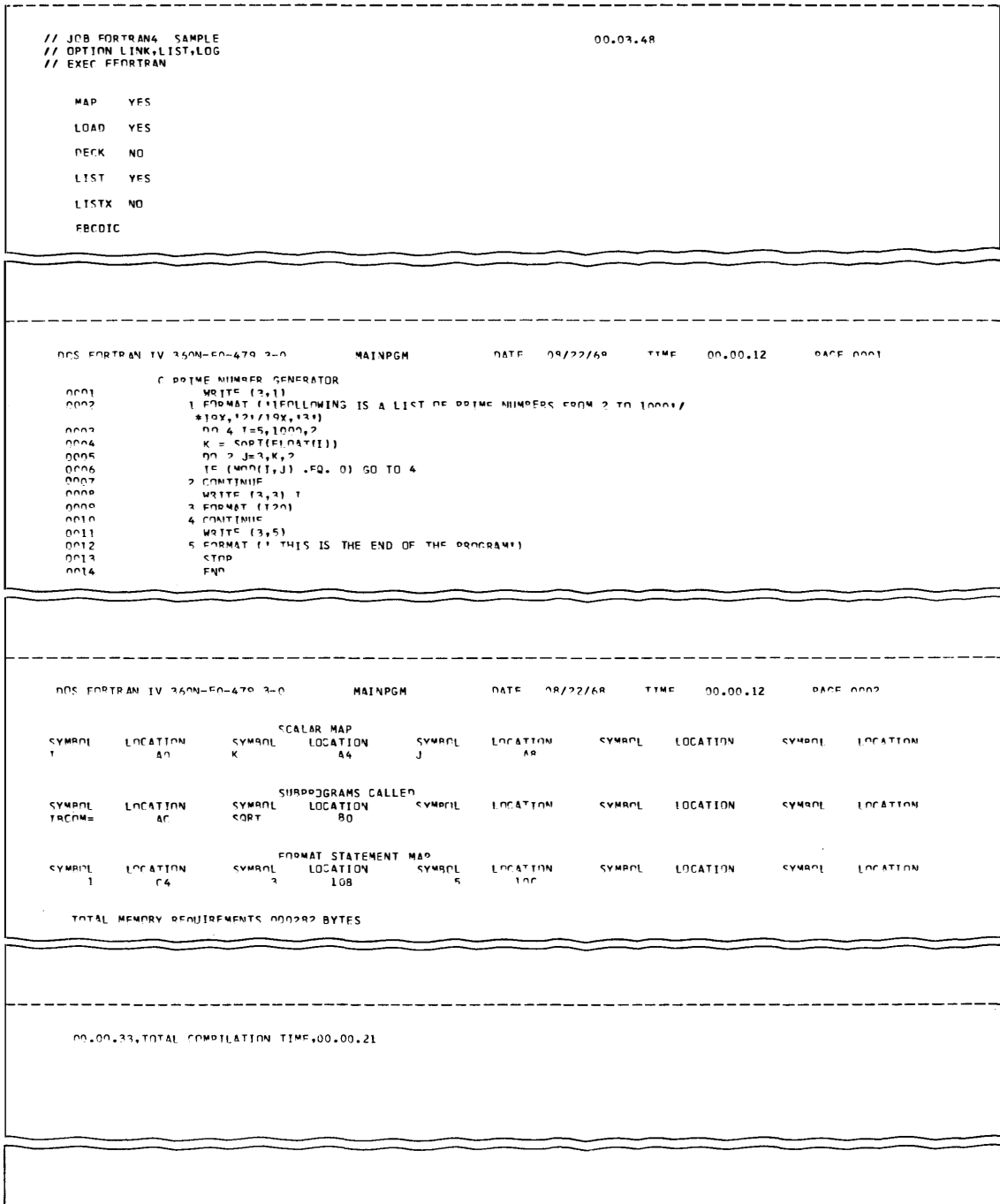

Figure 22. SYSLIST Output for FORTRAN 4 Sample Problems (Part 1 of 3)

```

// EXEC LINKED

JOB FORTRAN4 08/22/68 DISK LINKAGE EDITOR DIAGNOSTIC OF INPUT

ACTION TAKEN MAP
LIST AUTOLINK ILETRCON
LIST AUTOLINK ILEFCON
LIST AUTOLINK ILEFINT
LIST AUTOLINK ILEFIOCS
LIST AUTOLINK IJJCOIN
LIST AUTOLINK ILEFIOCS
LIST AUTOLINK ILESSORT
LIST AUTOLINK ILEINTAB
LIST ENTRY

08/22/68 PHASE XER-AD LOCORE HICORE OSK-AD FSD TYPE LABEL LADDED REL-FR
PHASE*** 002800 002800 005FEE 33 05 2 CSECT MAINDCH 002800 002800
CSECT ILETRCON 002888 002888
ENTRY TRCON= 002888
* ENTRY OPSYS 003720
ENTRY INTCM 003881
ENTRY PDBR 003680
ENTRY NUMDCW= 003635
* ENTRY IJTINTSW 003881
CSECT ILESSORT 005F40 005F40
ENTRY SORT 005F40
CSECT ILEFINT 004880 004880
ENTRY SAVERP 004880
CSECT ILEFCON 003000 003000
ENTRY ILEFCVEN 00448E
ENTRY ILEFCVLO 003062
ENTRY ILEFCVLO 003080
ENTRY ILEFCVLO 00468F
ENTRY ILEFCVAP 003802
ENTRY ILEFCVZQ 003820
ENTRY INT6SW 004888
CSECT ILEFIOCS 005070 005070
ENTRY ILEFIOCS 0058C4
ENTRY ILEFIOCS 0058C0
ENTRY IJYSVLO 0058A0
ENTRY ADIIOCS= 005828
CSECT ILEINTAB 005FF0 005FF0
CSECT ILEFIOCS 005C08 005C08
ENTRY ILEFIOCS 005C92
* ENTRY DIIOCS= 005C08
CSECT IJJCOIN 005A78 005A78
* ENTRY IJJCO3 005A78
CSECT IJ2L0905 005A08 005A70

// EXEC

```

Figure 22. SYSLST Output for FORTRAN 4 Sample Problems (Part 2 of 3)

```

FOLLOWING IS A LIST OF PRIME NUMBERS FROM 2 TO 1000
2
3
5
7
11
13
17
19
23
29
31
37
41
43
47
53
59
67
71
73
79
83
89
97
101
103
107
113
127
131
137
149
151
157
163
167
173
179
181
187
191
193
197
211
223
227
229
233
239
241
251
257
263
269
271
277
281
283
293
307
311
313
317
331
337
347
349
353
359
367
373
379
383
389
397
401
409
419
421
431
433
439
443
449
457
461
463
467
479
487
491
499
503
509
521
541
547
557
563
569
577
583
589
593
599
607
611
613
617
619
623
629
631
637
641
647
653
659
667
671
677
683
689
691
697
701
707
711
719
727
731
733
737
739
743
749
751
757
761
767
771
773
779
787
791
797
801
809
811
817
821
823
827
829
833
839
847
851
853
857
859
863
869
871
877
881
883
887
891
893
897
901
907
911
913
917
919
923
929
931
937
941
943
947
953
959
967
971
973
977
981
983
989
991
997

```

THIS IS THE END OF THE PROGRAM

END FORTRAN4

00.02.17, DMRAT 174 00.02.11

Figure 22. SYSLSLST Output for FORTRAN 4 Sample Problems (Part 3 of 3)

COBOL

Program Name is Z.CB1. The COBOL sample problem generates and prints a table of weekly, monthly, and annual salaries based on ten dollar increments in monthly salary from \$500 to \$1000. To execute the COBOL sample problem the following job control cards are needed:

```
// JOB COBOL SAMPLE
// OPTION LINK,LIST,IOG,LISTX,DUMP,SYM,ERRS
// EXEC COBOL
// CCBOL SOURCE DECK (81 cards)
/*
// EXEC LNKEDT
// ASSGN SYS004,X'cuu' (SYS004 must be assigned to printer designated as
// SYSLST during system generation)
// EXEC
/£
```

SYSLIST output is shown in Figure 17.

The following list summarizes the SYSLST output shown in Figure 23:

- Job control cards
- Source program listing
- Data division storage map
- Procedure division storage map
- Diagnostics
- Linkage editor storage map
- Table of salaries generated by the program

Note: Output is on SYS004 (same as printer).

```
// JOB COBOL SAMPLE
// OPTION LINK,LIST,LOG,LISTX,DUMP,SYM,ERRS
// EXEC COBOL
```

LINE NO.	SEQ. NO.	SOURCE STATEMENT	CBD CL3-0
1	001010	IDENTIFICATION DIVISION.	\$4520001
2	001020	PROGRAM-ID. 'C360SAMP'.	\$4520002
3	001030	REMARKS.	\$4520003
4	001040	EXAMPLE OF A 360 COBOL PROGRAM TO	\$4520004
5	001050	COMPUTE SALARIES.	\$4520005
6	001060	ENVIRONMENT DIVISION.	\$4520006
7	001070	CONFIGURATION SECTION.	\$4520007
8	001080	SOURCE-COMPUTER. IBM-360.	\$4520008
9	001090	OBJECT-COMPUTER. IBM-360.	\$4520009
10	001100	INPUT-OUTPUT SECTION.	\$4520010
11	001110	FILE-CONTROL.	\$4520011
12	001120	SELECT SALARY-FILE	\$4520012
13	001130	ASSIGN TO 'SYS004' UNIT-RECORD 1403.	\$4520013
14	001140		\$4520014
15	001150	DATA DIVISION.	\$4520015
16	001160	FILE SECTION.	\$4520016
17	001170	FD SALARY-FILE	\$4520017
18	001180	LABEL RECORDS ARE OMITTED	\$4520018
19	001185	RECORDING MODE IS F	\$4520019
20	001190	DATA RECORD IS SALARY-RECORD.	\$4520020
21	001200	01 SALARY-RECORD	\$4520021
22	001210	PICTURE X(100).	\$4520022
23	001220	WORKING-STORAGE SECTION.	\$4520023
24	001230	77 TOTAL-A PICTURE 9(6)V99 VALUE ZERO.	\$4520024
25	001240	77 TOTAL-B PICTURE 9(6)V99 VALUE ZERO.	\$4520025
26	001250	77 TOTAL-C PICTURE 9(6)V99 VALUE ZERO.	\$4520026
27	002010	77 WEEKLY-PAY PICTURE 999V99.	\$4520027
28	002020	77 MONTHLY-PAY PICTURE 9999V99.	\$4520028
29	002030	77 ANNUAL-PAY PICTURE 99999V99.	\$4520029
30	002040	77 CUN-A PICTURE 9(6)V99 VALUE IS 008826.69.	\$4520030
31	002050	77 CUN-B PICTURE 9(6)V99 VALUE IS 038250.00 .	\$4520031
32	002060	77 CUN-C PICTURE 9(6)V99 VALUE IS 459000.00 .	\$4520032
33	002070	01 SALARIES.	\$4520033
34	002080	02 FILLER PICTURE A(46) VALUE SPACE.	\$4520034
35	002090	02 WEEKLY PICTURE ZZZ.99 .	\$4520035
36	002100	02 FILLER PICTURE AAA VALUE SPACE.	\$4520036
37	002110	02 MONTHLY PICTURE ZZZ.99 .	\$4520037
38	002120	02 FILLER PICTURE AAA VALUE SPACE.	\$4520038
39	002130	02 ANNUAL PICTURE ZZZZ.99 .	\$4520039
40	002140	02 FILLER PICTURE A(27) VALUE SPACE.	\$4520040
41	002150	01 MESSAGES.	\$4520041
42	002160	02 FILLER PICTURE A(40) VALUE SPACES.	\$4520042
43	002170	02 SHOW PICTURE A(26).	\$4520043
44	002180	01 DISPLAY.	\$4520044
45	002190	02 FILLER PICTURE A(40) VALUE SPACES.	\$4520045
46	002200	02 PRINT PICTURE A(33).	\$4520046
47	002210	01 HEADING.	\$4520047
48	002220	02 FILLER PICTURE A(46) VALUE SPACES.	\$4520048
49	002230	02 WEEKLY PICTURE A(6) VALUE IS 'WEEKLY'.	\$4520049
50	002240	02 FILLER PICTURE A(3) VALUE IS SPACES.	\$4520050
51	002250	02 MONTHLY PICTURE A(7) VALUE IS 'MONTHLY'.	\$4520051
52	003010	02 FILLER PICTURE A(3) VALUE IS SPACES.	\$4520052
53	003020	02 ANNUAL PICTURE A(6) VALUE IS 'ANNUAL'.	\$4520053
54	003030	02 FILLER PICTURE A(29) VALUE IS SPACES.	\$4520054

Figure 23. SYSLST Output for COBOL Sample Problems (Part 1 of 5)

LINE NO.	SEQ. NO.	SOURCE STATEMENT	
55	00304C		\$4520055
56	003050	PROCEEDURE DIVISION.	\$4520056
57	00306C	START.	\$4520057
58	00307G	OPEN OUTPUT SALARY-FILE.	\$4520058
59	00308G	WRITE SALARY-RECORD FROM HEADING AFTER ADVANCING 0 LINES.	\$4520059
60	003090	PERFORM CALCULATIONS	\$4520060
61	003100	VARYING MONTHLY-PAY FROM 500 BY 10	\$4520061
62	003110	UNTIL MONTHLY-PAY IS GREATER THAN 1000.	\$4520062
63	003120	IF TOTAL-A = CUM-A AND TOTAL-B = CUM-B AND TOTAL-C = CUM-C	\$4520063
64	00313C	MOVE *TABLE VALUES ARE CORRECT* TO SHOW	\$4520064
65	00314C	WRITE SALARY-RECORD FROM MESH AFTER ADVANCING 2 LINES	\$4520065
66	003150	ELSE	\$4520066
67	003160	MOVE *TABLE VALUES ARE NOT CORRECT* TO PRSNT	\$4520067
68	00317G	WRITE SALARY-RECORD FROM D\$PY AFTER ADVANCING 2 LINES.	\$4520068
69	003180	CLOSE SALARY-FILE.	\$4520069
70	00319C	STOP RUN.	\$4520070
71	00320C		\$4520071
72	003210	CALCULATIONS.	\$4520072
73	003220	COMPUTE WEEKLY-PAY = 3 * MONTHLY-PAY / 13	\$4520073
74	00323C	COMPUTE ANNUAL-PAY = 12 * MONTHLY-PAY	\$4520074
75	003240	MOVE WEEKLY-PAY TO WEEKLY IN SALARIES	\$4520075
76	00325C	MOVE MONTHLY-PAY TO MONTHLY IN SALARIES	\$4520076
77	004010	MOVE ANNUAL-PAY TO ANNUAL IN SALARIES	\$4520077
78	004020	ADD WEEKLY-PAY TO TOTAL-A	\$4520078
79	00403G	ADD MONTHLY-PAY TO TOTAL-B	\$4520079
80	004040	ADD ANNUAL-PAY TO TOTAL-C	\$4520080
81	00405C	WRITE SALARY-RECORD FROM SALARIES AFTER ADVANCING 1 LINES.	\$4520081

DATA DIVISION MAP

TYPE	LOCATION	DATA NAME
FILE		SALARY-FILE
REC	0000000	SALARY-RECORD
	0000000	TOTAL-A
	0000008	TOTAL-B
	0000010	TOTAL-C
	0000018	WEEKLY-PAY
	000001D	MONTHLY-PAY
	0000023	ANNUAL-PAY
	000002A	CUM-A
	0000032	CUM-B
	000003A	CUM-C
REC	0000048	SALARIES
	0000076	WEEKLY
	000007F	MONTHLY
	0000089	ANNUAL
REC	0000090	MESH
	0000098	SHOW
REL	00000F8	D\$PY
	0000120	PRSNT
REC	0000148	HEADING
	0000176	WEEKLY
	000017F	MONTHLY
	0000189	ANNUAL

Figure 23. SYSLST Output for COBOL Sample Problems (Part 2 of 5)

PROCEDURE DIVISION MAP								
LINE/POS	ADDR	INSTRUCTION	LINE/POS	ADDR	INSTRUCTION	LINE/POS	ADDR	INSTRUCTION
00057	01	000508	0A	10				
00058	01	000514	50	00	A	10C		
00058	01	000522	50	00	A	1CC		
00058	01	000530	41	10	A	320		
00058	01	00053A	41	10	A	310		
00058	01	000544	58	90	A	1E0		
00059	01	000552	12	02	3	011	A	1F1
00059	01	000566	50	10	3	018		
00059	01	000578	5C	10	3	018		
00059	01	000586	06	10				
00059	01	000590	50	00	A	108		
00059	01	00059C	41	10	A	1C8		
00059	01	000584	0A	07				
00059	01	0005C2	58	90	A	1E0		
00060	01	0005D2	92	F0	A	01D		
00060	01	0005E2	03	00	A	022	A	020
00062	01	0005F0	F2	35	3	038	A	010
00062	01	000602	01	01	3	03A	A	200
00062	01	000614	47	20	3	326		
00060	01	000620	47	F0	3	4C0		
00060	01	000630	D3	01	3	00D	A	2DA
00060	01	000642	FA	FF	3	168	3	000
00060	01	000652	47	FJ	3	2C0		
00063	01	000662	F2	47	3	054	A	02A
00063	01	000672	F2	47	3	03E	A	008
00063	01	000684	47	70	3	40A		
00063	01	000694	F9	44	3	03E	3	054
00063	01	000704	92	40	A	0F0		
00063	01	000714	92	40	A	042		
00063	01	000724	D2	02	3	011	A	1F1
00063	01	000732	50	10	3	018		
00063	01	000740	50	10	3	018		
00063	01	000750	50	10	3	018		
00063	01	000760	06	10				
00063	01	000770	50	00	A	108		
00063	01	000780	41	10	A	1C8		
00063	01	000790	50	00	A	108		
00063	01	000802	0A	07				
00063	01	000812	58	90	A	1E0		
00063	01	000824	50	00	3	010		
00063	01	000834	F2	F5	3	178	A	010
00063	01	000844	F2	F0	3	000	A	023
00063	01	000854	92	F6	3	000	A	017
00063	01	000864	D2	02	3	011	A	1F1
00063	01	000874	50	10	3	018		
00063	01	000884	50	10	3	018		
00063	01	000894	06	10				
00063	01	000904	50	00	A	108		
00063	01	000914	41	10	A	1C8		
00063	01	000924	50	00	A	108		
00063	01	000934	41	10	A	1C8		
00063	01	000944	0A	07				
00063	01	000954	58	90	A	1E0		
00063	01	000964	58	90	A	1E0		

PROCEDURE DIVISION MAP								
LINE/POS	ADDR	INSTRUCTION	LINE/POS	ADDR	INSTRUCTION	LINE/POS	ADDR	INSTRUCTION
00073	01	000812	01	00	3	16E	3	187
00073	01	000824	D3	00	3	024	3	025
00073	01	000834	F2	F5	3	168	A	010
00073	01	000844	96	F0	A	029		
00073	01	000854	0E	06	3	038	3	010
00073	01	000864	D2	08	3	038	A	183
00073	01	000874	F2	36	3	010	A	023
00073	01	000884	D2	07	A	089	3	039
00073	01	000894	FA	FF	3	168	3	000
00073	01	0008A4	F2	F7	3	168	A	008
00073	01	0008B4	F3	7F	A	008	3	168
00073	01	0008C4	F3	7F	A	008	3	168
00073	01	0008D4	F2	F6	3	000	A	023
00073	01	0008E4	92	F0	A	017		
00073	01	0008F4	D2	02	3	011	A	1F1
00073	01	000904	50	10	3	018		
00073	01	000914	50	10	3	018		
00073	01	000924	06	10				
00073	01	000934	50	00	A	108		
00073	01	000944	41	10	A	1C8		
00073	01	000954	0A	07				
00073	01	000964	58	90	A	1E0		

Figure 23. SYSLST Output for COBOL Sample Problems (Part 3 of 5)

```

                                DIAGNOSTICS

LINE/PGS ER CODE  CLAUSE                MESSAGE
21- 1 IJS063I W ALIGNMENT  TO ALIGN BLOCKED RECORDS ADD 4 BYTES TO THE 01 CONTAINING DATANAME SALARY-RECORD.
33- 1 IJS053I W ALIGNMENT  FOR PROPER ALIGNMENT, A 6 BYTE LONG FILLER ENTRY IS INSERTED PRECEDING SALARIES.
41- 1 IJS053I W ALIGNMENT  FOR PROPER ALIGNMENT, A 4 BYTE LONG FILLER ENTRY IS INSERTED PRECEDING MSG.
44- 1 IJS053I W ALIGNMENT  FOR PROPER ALIGNMENT, A 6 BYTE LONG FILLER ENTRY IS INSERTED PRECEDING DSPY.
47- 1 IJSC53I W ALIGNMENT  FOR PROPER ALIGNMENT, A 7 BYTE LONG FILLER ENTRY IS INSERTED PRECEDING HEADING.

                                DIAGNOSTICS

5 LEVEL W DIAGNOSTICS

// EXEC LNKEBT

JOB C06GL 01/01/68 DISK LINKAGE EDITOR DIAGNOSTIC OF INPUT
ACTION TAKEN MAP
LIST INCLUDE IH003300 C3600001
LIST AUTOLINK IJDFAPIZ
LIST ENTRY

01/01/68 PHASE XFR-AD LOGORE HICORE DSK-AD ESD TYPE LABEL LOADED REL-FR
PHASE*** 0025C0 002000 002B58 1D 2 1 CSECT IH003300 002000 002000
* ENTRY IH003301 002054
ENTRY IH003302 002000
CSECT C360SAMP 0020E8 0020E8
CSECT IJDFAPIZ 002A50 002A50
* ENTRY IJDFAZIZ 002A50

// ASSEN SYSC04,X*00E*
// EXEC

```

Figure 23. SYSLST Output for COBOL Sample Problems (Part 4 of 5)

WEEKLY	MONTHLY	ANNUAL
115.38	500.00	6000.00
117.69	510.00	6120.00
120.00	520.00	6240.00
122.30	530.00	6360.00
124.61	540.00	6480.00
126.92	550.00	6600.00
129.23	560.00	6720.00
131.53	570.00	6840.00
133.84	580.00	6960.00
136.15	590.00	7080.00
138.46	600.00	7200.00
140.76	610.00	7320.00
143.07	620.00	7440.00
145.38	630.00	7560.00
147.69	640.00	7680.00
150.00	650.00	7800.00
152.30	660.00	7920.00
154.61	670.00	8040.00
156.92	680.00	8160.00
159.23	690.00	8280.00
161.53	700.00	8400.00
163.84	710.00	8520.00
166.15	720.00	8640.00
168.46	730.00	8760.00
170.76	740.00	8880.00
173.07	750.00	9000.00
175.38	760.00	9120.00
177.69	770.00	9240.00
180.00	780.00	9360.00
182.30	790.00	9480.00
184.61	800.00	9600.00
186.92	810.00	9720.00
189.23	820.00	9840.00
191.53	830.00	9960.00
193.84	840.00	10080.00
196.15	850.00	10200.00
198.46	860.00	10320.00
200.76	870.00	10440.00
203.07	880.00	10560.00
205.38	890.00	10680.00
207.69	900.00	10800.00
210.00	910.00	10920.00
212.30	920.00	11040.00
214.61	930.00	11160.00
216.92	940.00	11280.00
219.23	950.00	11400.00
221.53	960.00	11520.00
223.84	970.00	11640.00
226.15	980.00	11760.00
228.46	990.00	11880.00
230.76	1000.00	12000.00

TABLE VALUES ARE CORRECT

END COBOL

Figure 23. SYSLIST Output for COBOL Sample Problems (Part 5 of 5)

RPG

Program Name is Z.RG1. The RPG sample problem produces an accounts receivable register. Both the RPG source deck and data deck are retrieved from the maintenance volume under Retrieving the Sample Problems. To execute the RPG sample problem the following job control cards are needed:

```
// JOB RGP SAMPLE
// OPTION LINK,DUMP
// EXEC RPG
  RPG SOURCE DECK (45 cards)
/*
// EXEC LNKEDT
// EXEC
  RPG DATA (13 cards)
/*
/£
```

SYSLOG output is shown in Figure 17.

The following list summarizes the SYSLST output shown in Figure 24.

- Job control cards
- Source program listing
- Symbol tables
- Memory map
- Linkage editor storage map
- Accounts receivable register generated by program

```

DSN/360*RP9CL 3-D          RPG
                                SYMBOL TABLE
RESULTING INDICATORS
ADDRESS R1      ADDRESS R1      ADDRESS R1      ADDRESS R1      ADDRESS R1      ADDRESS R1      ADDRESS R1
CG0011 0F      000014 1P      000015 1R      000016 0U      000017 0I      00007A L6      00007B L1
CG0085 0G      000086 0H      000087 0Z      000088 03      000089 04      00008A 05      00008B 06
00008C 07      00008D 08      00008E 09
FIELD NAMES
ADDRESS FIELD      ADDRESS FIELD      ADDRESS FIELD      ADDRESS FIELD      ADDRESS FIELD
CG0011 NAME        CG0014 MONTH      CG0015 DAY         CG0016 INVOICE    CG0017 INVOICE
CG0012 STATE       CG0018 FEE        CG0019 INVOICE     CG0020 TOTAL      CG007A INVOICE
CG0013 **          CG0019 **         CG0019 **         CG0019 **         CG0019 **

LITERALS
ADDRESS LITERAL      ADDRESS LITERAL      ADDRESS LITERAL
00015B A C C U N T S R  CG016B E C E I V A B L E R E  000183 G I S T E R
00018E CUSTOMER          000196 LOCATION INVOICE      000184 INVOICE DATE INVOICE
0001C3 NUMBER           CUSTOMER  00010B NAME                   00010F STATE CITY INVOICE
0001F7 MO DAY AMOUNT    00020C , .                     000217 $
000218 **

                                MEMORY
INPUT/OUTPUT INTERCEPT  000218
TABLE (INPUT AND OUTPUT)  000219
DETERMINE RECORD TYPE     00021A
DATA SPECIFICATION        00021B
GET INPUT RECORD          00021C
DETAIL CALCULATIONS        00021D
TOTAL CALCULATIONS        00021E
DETAIL LINES               00021F
TOTAL LINES               000220
INPUT/OUTPUT REQUEST BLOCKS POINTER  000221
LOCATION OF DIF TABLE POINTERS  000222
INPUT/OUTPUT INTERFACE POINTERS  000223
WORK AREA POINTER        000224
OVERFLOW BYPASS          000225
LINKAGE LEVEL            000226
TABLE (ASSEMBLE 4)       000227
TEST ZONE (DCU)          000228
OVERFLOW LINES           000229
LINKAGE PROGRAM           000230

PROGRAM LENGTH 000230

```

Figure 24. SYSLST Output for RPG Sample Problems (Part 2 of 3)

JOB RPG		DISK LINKAGE EDITOR DIAGNOSTIC OF INPUT						
ACTION TAKEN	MAP						\$4600119	
LIST	INCLUDE	IJCFI1ZO					\$4600120	
LIST	INCLUDE	IJDFYPZZ						
LIST	ENTRY							

01/01/68	PHASE	XFR-AD	LUCORE	HICORE	DSK-AD	ESD TYPE	LABEL	LOADED	REL-FR
	PHASE***	003518	C02000	0038EB	19 4 1	CSECT	\$460	002000	002000
						CSECT	IJCFI1ZO	003708	003708
						* ENTRY	IJCFI1ZO	003708	
						CSECT	IJDFYPZZ	003870	003870
						* ENTRY	IJDFYZZZ	003870	

// EXEC

ACCOUNTS RECEIVABLE REGISTER							
CUSTOMER NUMBER	CUSTOMER NAME	LOCATION STATE	CITY	INVOICE NUMBER	INVOICE NO	DATE DAY	INVOICE AMOUNT
10712	AMALGAMATED CORP	53	61	11603	11	10	\$ 389.25
							\$ 389.25*
11315	BROWN WHOLESale	30	231	12324	12	28	\$ 802.08
11315	BROWN WHOLESale	30	231	99588	12	14	\$ 261.17
							\$ 1,063.25*
11897	FARM IMPLEMENTS	47	77	10901	10	18	\$ 27.63
							\$ 27.63*
18530	BLACK OIL	16	67	11509	11	8	\$ 592.95
18530	BLACK OIL	16	67	12292	12	23	\$ 950.97
							\$ 1,543.92*
20716	LEATHER BELT CO	36	471	11511	11	8	\$ 335.63
20716	LEATHER BELT CO	36	471	12263	12	17	\$ 121.75
							\$ 457.38*
29017	GENERAL MFG CO	6	63	11615	11	14	\$ 440.12
29017	GENERAL MFG CO	6	63	11676	11	23	\$ 722.22
							\$ 1,162.34*
29054	A-B-C DIST CO	25	39	9689	9	11	\$ 645.40
29054	A-B-C DIST CO	25	39	11605	11	11	\$ 271.69
29054	A-B-C DIST CO	25	39	12234	12	14	\$ 559.33
							\$ 1,476.42*
							\$ 6,120.19**

EOJ RPG

Figure 24. SYSLST Output for RPG Sample Problems (Part 3 of 3)

PL/I

Program Name is Z.PL1. The PL/I sample problem produces a table of mathematical functions: $\text{SQRT}(x^2+1)$, x^2 , x^3 , $\text{SIN}(x)$, $\text{COS}(x)$, $\text{SQRT}(x)$, and $\text{SQRT}(x^3)$. To execute the PL/I sample problem the following job control cards are needed:

```
// JOB PL/I SAMPLE
// OPTION LINK,NODECK,SYM,LISTX,48C,XREF
// EXEC PL/I
// PROCESS STMT
//   PL/I source deck (38 cards)
/*
// EXEC LNKEDT
// EXEC
//   PL/I data (1 card)
/*
/£
```

SYSLIST output is shown in Figure 17.

The following list summarizes the SYSLIST output shown in Figure 25.

- Job control cards
- Source program listing
- Symbol table listing
- Offset table listing
- Object program listing
- External symbol table
- Block table (automatic storage requirements)
- Linkage editor storage map
- Table produced by object program

```
// JOB PL/I SAMPLE
// OPTION LINK,LIST,LISTX,SYM,NODECK,48C
// EXEC PL/I
```

DOS PL/I COMPILER 360N-PL-464 CL3-4 PL/I 02/26/69 PAGE 001

OPT I O N S L I S T

```
* PRCESS STMT,OPT,XREF
OPTIONS TAKEN ARE LIST,LISTX,SYM,XREF,EPDS,48C,OPT,STMT.
```

DOS PL/I COMPILER 360N-PL-464 CL3-4 PL/I 02/26/69 PAGE 002

```
/*PL/I SAMPLE PROGRAM FOR DOS/TOS */
```

```

1          /*PL/I SAMPLE PROGRAM FOR DOS/TOS */          $4640001
2          PL1..PROCEDURE OPTIONS (MAIN) ..              $4640002
              DECLARE ( X, BEGIN, END, STEP, A(5), B(2) ) $4640003
                  FLOAT BINARY (21) ..                  $4640004
              /* THIS PROGRAM COMPUTES A SMALL TABLE CONTAINING A FEW $4640005
                  MATH. FUNCTIONS.                      $4640006
                  INPUT DATA.. BEGIN - START POINT OF TABLE , $4640007
                  END - END POINT TABLE ,              $4640008
                  STEP - STEP WIDTH IN TABLE ,         $4640009
                  THE ABSOLUTE VALUES OF BEGIN AND END MAY NOT BE GREATER $4640010
                  THAN 999.999, THE ABSOLUTE VALUE OF STEP MAY NOT BE LESS $4640011
                  THAN 0.001 .                            $4640012
              */ $4640013
3          GET EDIT (BEGIN, END, STEP) ( F(8,3) ) ..    $4640014
4          PUT EDIT ('X SQRT(X**2+1) X**2,'X**3','SIN(X) $4640015
              SQRT(X) SQRT(X**3) (X(4),A(4),A(14),A(61)) .. $4640016
5          COS(X) IF ABS(BEGIN) GE 1000 OR ABS(STEP) LT .000999 $4640017
                  THEN GO TO INPUTERROR ..             $4640018
6          DO X=BEGIN TO END+STEP/IE3 BY STEP ..       $4640019
7          A(2)=X*X ..                                  $4640020
8          A(1)=SQRT(A(2)+1) ..                          $4640021
9          A(3)=A(2)*X ..                                $4640022
10         A(4)=SIN(X) ..                                $4640023
11         A(5)=COS(X) ..                                $4640024
12         PUT EDIT (X,A) ( F(8,3),F(13,3),2 E(16,5),2 F(13,6) ) .. $4640025
13         IF X LT 0 THEN GO TO NEG ..                   $4640026
14         B(1)=SQRT(X) ..                                $4640027
15         B(2)=SQRT(A(3)) ..                             $4640028
16         PUT EDIT (B,' ') ( F(12,4), E(16,5),A(13) ) .. $4640029
17         GO TO ENDL00P ..                               $4640030
18         NEG.. PUT EDIT ('--','--') (X(7), A(15), A(19)) .. $4640031
19         ENDL00P.. END /* DO LOOP */ ..                $4640032
20         PUT SKIP EDIT (' NORMAL END')(A) ..           $4640033
21         RETURN /* NORMAL END */ ..                   $4640034
22         INPUTERROR..                                  $4640035
23         PUT EDIT ('INPUT DATA ERROR')(A(12)) ..     $4640036
24         STOP /* END ON WRONG INPUT */ ..              $4640037
25         END /* TABLE */ ..                          $4640038
```

DOS PL/I COMPILER 360N-PL-464 CL3-4 PL/I 02/26/69 PAGE 003

S Y M B O L T A B L E L I S T I N G

PL1	0100 00 0	ENTRY	ARITHM.	DECIMAL	FLOAT	6	EXT
X	0101 01 1		ARITHM.	BINARY	FLOAT	21	AUTOM. INT
BEGIN	0102 01 1		ARITHM.	BINARY	FLOAT	21	AUTOM. INT
END	0103 01 1		ARITHM.	BINARY	FLOAT	21	AUTOM. INT
STEP	0104 01 1		ARITHM.	BINARY	FLOAT	21	AUTOM. INT
A	0105 01 1	ARRAY	ARITHM.	BINARY	FLOAT	21	AUTOM. INT
B	0106 01 1	ARRAY	ARITHM.	BINARY	FLOAT	21	AUTOM. INT
NEG	0107 01 1		LABEL	CONST.			INT
ENDL00P	0108 01 1		LABEL	CONST.			INT
INPUTERROR	0109 01 1		LABEL	CONST.			INT

Figure 25. SYSLST Output for PL/I Sample Programs (Part 1 of 4)

DOS PL/I COMPILER 360N-PL-464 CL3-4		PL/I	02/26/69	PAGE 004
CROSS REFERENCE LISTING				
A	0105 01	7	8	8 9 10 11 12 15
B	0106 01	14	15	16
BEGIN	01C2 01	3	5	6
END	0103 01	3	6	
ENDLCOP	0108 01	17	19	
INPUTERRCR	0109 01	5	23	
NEG	0107 01	13	18	
PL1	0100 00	1		
STEP	0104 01	3	5	6 6 10 11 12 13 14
X	0101 01	6	7	7 9 10 11 12 13 14

DOS PL/I COMPILER 360N-PL-464 CL3-4		PL/I	02/26/69	PAGE 005
INTERNAL NAME	OFFSET	TYPE	MODULE OFFSET	OFFSET TABLE
0100	001C	STATIC	00042C	
0101	011C	AUTOMATIC		
0102	0120	AUTOMATIC		
0103	0124	AUTOMATIC		
0104	0128	AUTOMATIC		
0105	0130	AUTOMATIC		
0106	0148	AUTOMATIC		

DOS PL/I COMPILER 360N-PL-464 CL3-4		PL/I	02/26/69	PAGE 006
LOC.	OBJECT CODE	LABEL	OP.	OPERANDS
000000	05F0		BALR	F,0
000002		L'0100'	BEGIN	OF BLOCK 01
000002	0700		BCR	0,0
000004	45E0 F00A		BAL	E,X'00A'(F)
000008	00000410		DC	A(N'FFFF')
00000C	58C0 E000		L	C,X'000'(E)
000010	189F		LR	9,F
000012	1831		LR	3,1
000014	58F0 C05C		L	F,N'0011'
000018	05E0		BALR	E,0
00001A	41E0 E00E		LA	E,X'00E'(E)
00001E	051F		BALR	1,F
000020	83		DC	X'83'
000021	000428		DC	AL3(N'010A')
000024	00000150		DC	LENGTH OF DSA OF BLOCK 01
000028	4110 C02C		LA	1,X'02C'(C)
00002C	58F0 C054		L	F,N'0016'
000030	05EF		BALR	E,F
000032	0203 0050 3000		MVC	X'050'(04,D),X'000'(3)
000038	4700 0001		BC	0,X'001'

STATEMENT NUMBER 1

DOS PL/I COMPILER 360N-PL-464 CL3-4		PL/I	02/26/69	PAGE 014	
SYMBOL	TYPE	FSID	ADDR	LENGTH ESID	EXTERNAL SYMBOL TABLE
PL1	SD	0001	000000	000568	
IJKS2CA	ER	0002			
IJKS2CH	ER	0003			
IJKS2CT	ER	0004			
IJKS2LM	ER	0005			
IJKTFDM	ER	0006			
IJKTFPM	ER	0007			
IJKTSTM	ER	0008			
IJKVTCM	ER	0009			
IJKVECM	ER	000A			
IJKTSTR	ER	000B			
IJKVCTM	ER	000C			
IJKVCEM	ER	000D			
IJKSYSI	ER	000E			
IJKSYSA	ER	000F			
IJKQSQM	ER	0010			
IJKQSSD	ER	0011			
IJKQSSB	ER	0012			
IJKS2BA	ER	0013			

Figure 25. SYSLST Output for PL/I Sample Programs (Part 2 of 4)

```

DOS PL/I COMPILER 360N-PL-464 CL3-4          PL/I          02/26/69          PAGE 015
BLOCK      LENGTH OF DSA      BLOCKTABLE
01         0150

-----

DOS PL/I COMPILER 360N-PL-464 CL3-4          PL/I          02/26/69          PAGE 016
DW011     SUCCESSFUL  COMPILATION

-----

// EXEC LNKEDT

-----

JGB PL/I          02/26/69  DISK LINKAGE EDITOR DIAGNOSTIC OF INPUT
ACTION TAKEN      MAP
LIST  AUTOLINK    IJKQSQM
LIST  AUTOLINK    IJKQSSD
LIST  AUTOLINK    IJKSYSA
LIST  AUTOLINK    IJJCPIN
LIST  AUTOLINK    IJKSYSI
LIST  AUTOLINK    IJKSZBA
LIST  AUTOLINK    IJKSZLM
LIST  AUTOLINK    IJKTFFM
LIST  AUTOLINK    IJKTFFM
LIST  AUTOLINK    IJKTSTM
LIST  AUTOLINK    IJKTxcf
LIST  AUTOLINK    IJKVCEM
LIST  AUTOLINK    IJKVCTM
LIST  AUTOLINK    IJKVECM
LIST  AUTOLINK    IJKVTCM
LIST  AUTOLINK    IJKXTBM
LIST  ENTRY

```

Figure 25. SYSLST Output for PL/I Sample Programs (Part 3 of 4)

```

12/26/69 PHASE XFR-AD LOCORE HICORE DSK-AD ESD TYPE LABEL LOADED REL-FR
PHASE*** 002800 002800 004717 28 06 2 CSECT PL1 002800 002800
CSECT IJKSZLM 003878 003878
CSECT IJKTFDM 003888 003888
CSECT IJKTFMM 003A98 003A98
ENTRY IJKTFMR 003AAC
CSECT IJKTSTM 003B60 003B60
ENTRY IJKTSTR 003D64
ENTRY IJKTSTN 003B0A
CSECT IJKVTCM 004578 004578
CSECT IJKVECM 0043E0 0043E0
CSECT IJKVCTM 004258 004258
CSECT IJKVCEM 003E80 003E80
CSECT IJKSYSI 0030F0 0030F0
CSECT IJKSYSA 002F48 002F48
CSECT IJKQSM 002D68 002D68
CSECT IJKQSSA 002E18 002E18
ENTRY IJKQSSD 002E40
ENTRY IJKQSSB 002E20
* ENTRY IJKQSSC 002E38
CSECT IJJCPIN 003018 003018
ENTRY IJJCP3 003018
CSECT IJKTXCF 003E08 003E08
* ENTRY IJKTXCR 003E30
* ENTRY IJKTXCW 003E42
CSECT IJKSZCN 003188 003188
ENTRY IJKSZCA 003386
ENTRY IJKSZCM 00338E
ENTRY IJKSZCT 0033DA
ENTRY IJKSZBA 0033BA
ENTRY IJKZWSA 003468
ENTRY IJKSZCS 00323E
* ENTRY IJKSZCI 00321A
* ENTRY IJKSZCP 003348
* ENTRY IJKTCLM 0033FC
ENTRY IJKTOPM 0033EC
* ENTRY IJKZWSI 00358C
CSECT IJKXTBM 004698 004698

```

```

// EXEC

```

```

X      SQRT(X**2+1)      X**2      X**3      SIN(X)      COS(X)      SQRT(X)      SQRT(X**3)
.000      1.000      .00000E+00      .00000E+00      .000000      1.000000      .0000      .00000E+00
.100      1.005      9.99999E-03      9.99999E-04      .099833      .995004      .3162      3.16228E-02
.200      1.020      4.00000E-02      7.99999E-03      .198669      .980067      .6472      8.94426E-02
.300      1.044      8.99999E-02      2.70000E-02      .295520      .955337      .95477      1.64317E-01
.400      1.077      1.60000E-01      6.39999E-02      .389418      .921061      .6325      2.52982E-01
.500      1.118      2.50000E-01      1.25000E-01      .479425      .877583      .7071      3.53553E-01
.600      1.166      3.60000E-01      2.16000E-01      .564642      .825336      .7746      4.64758E-01

```

```

2.500      2.693      6.24996E+00      1.56248E+01      .598479      -.801139      1.5811      3.95283E+00
2.600      2.786      6.75995E+00      1.75758E+01      .515509      -.856884      1.6124      4.19235E+00
2.700      2.879      7.28995E+00      1.96828E+01      .427389      -.904068      1.6432      4.43653E+00
2.800      2.973      7.83994E+00      2.19518E+01      .334998      -.942219      1.6733      4.68527E+00
2.900      3.068      8.40994E+00      2.43887E+01      .239260      -.970956      1.7029      4.93849E+00
3.000      3.162      8.99993E+00      2.69997E+01      .141131      -.989991      1.7320      5.19612E+00
NORMAL END

```

```

EGJ PL/I 14.06.55,DURATION 00.02.19

```

Figure 25. SYSLST Output for PL/I Sample Programs (Part 4 of 4)

Assembler 1

Program Name is Z.AS1. The Assembler 1 sample problem generates numbers from 2000 to 0001 in descending order and writes them on tape as 15 character unblocked records (11 blanks followed by 4 zone digits, unsigned). To execute the Assembler 1 sample problem the following job control cards are needed:

```
// JOB ASSEMBLE SAMPLE 1.  
// OPTION LINK,LIST,LOG,NOXREF  
// EXEC ASSEMBLY  
    ASSEMBLER SOURCE DECK (23 cards)  
/*  
// EXEC LNKEDT  
// PAUSE ASSGN SYS002 TO A 9 TRACK TAPE DRIVE  
// ASSGN SYS002,X'cuu'  
// MTC REW,SYS002  
// EXEC  
/E
```

SYSLLOG output is shown in Figure 17.

The following list summarizes the SYSLST output shown in Figure 26:

- Job control cards
- External symbol dictionary
- Source program listing
- Relocation dictionary
- Linkage editor storage map

```
// JOB ASSEMBLE SAMPLE 1
// OPTION LINK,LIST,LOG,NOXREF
// EXEC ASSEMBLY
```

EXTERNAL SYMBOL DICTIONARY

SYMBOL	TYPE	ID	ADDR	LENGTH	LD	ID
	PC	C1	C00000	000124		
IJFFZZZZ	ER	O2				
IJFFZZZZ	SD	O3	000128	00028A		

SMPL DUS ASSEMBLER TEST

LOC	OBJECT CODE	ADDR1	ADDR2	STMT	SOURCE STATEMENT	DOS CL3-0
				2	PRINT NOGEN	\$4650002
				3	START 0	\$4650003
000000	0580			4	TESTGEN BALR 8,0	\$4650004
				5	USING *,8	\$4650005
000002	41D0 80C6		000C8	6	LA 13,SAVEAREA	\$4650006
				7	OPEN OUTFILE	\$4650007
000016	4130 07D0		007D0	15	LA 3,2000	\$4650008
00001A	4E30 80BE		000C0	16	NEXT CVD 3,DWD	\$4650009
00001E	F337 2008 80bE 00G08		000C0	17	UNPK 11(4,2),DWD	\$4650010
000024	96F0 200E		0000E	18	OI 14(2),X*FO'	\$4650011
				19	PUT OUTFILE	\$4650012
000034	4630 8018		0001A	24	BCT 3,NEXT	\$4650013
				25	CLOSE OUTFILE	\$4650014
				33	EUJ	\$4650015
				36	OUTFILE DTFMT BLKSIZE=15,DEVADDR=SYS002,FILABL=NO,IOAREA1=A1,IOAREA2=A2,IOREG=(2),TYPEFL=OUTPUT	\$4650016
				68	MTMOD RECFORM=FIXUNB	\$4650017
00005E	4040404040404040			292	A1 DC 15C' '	\$4650018
0000AD	4040404040404040			293	A2 DC 15C' '	\$4650019
0000C0				294	DWD DS 0	\$4650020
0000C8				295	SAVEAREA DS 9D	\$4650021
0000D0				296	END	\$4650022
000110	5b58c2d6d7c5d540			297	TESTGEN	\$4650023
000118	5858c2c3d3d6e2c5			298	=C' \$\$\$BOPEN'	
000120	CC00CC48			299	=C' \$\$\$BCLUSE'	
					=A(OUTFILE)	

RELOCATION DICTIONARY

POS.ID	REL.ID	FLAGS	ADDRESS
01	01	0C	00001C
01	01	0C	000040
01	01	0C	000050
01	02	18	000059
01	01	C8	000060
01	01	08	000081
01	01	0C	000088
01	01	0C	00008C
01	01	0C	000094
01	01	0C	000120

NO STATEMENTS FLAGGED IN THIS ASSEMBLY

Figure 26. SYSLST Output for Assembler (AS1) Sample Programs (Part 1 of 2)

```
// EXEC LNKEBT
```

```
JOB ASSEMBLE          DISK LINKAGE EDITOR DIAGNOSTIC OF INPUT
ACTION TAKEN      MAP
LIST ENTRY
```

```
PHASE  XFR-AD  LUCORE  HICORE  DSK-AD  ESD TYPE  LABEL    LOADED  REL-FR
PHASE*** 002000  002000  0023E1  20 3 1  CSECT      002000  002000
                                     CSECT      1JFFZZZZ  00212B  002000
```

```
// PAUSE // ASSGN SYS002 TO A 9 TRACK TAPE DRIVE
// ASSGN SYS002,X*180*
// MTC REM,SYS002
// EXEC
```

```
EOJ ASSEMBLE
```

Figure 26. SYSLST Output for Assembler (AS1) Sample Programs (Part 2 of 2)

Tape Sort/Merge

Program Name is Z.SM1. The tape sort/merge sample problem rearranges the records produced by the Assembler 1 program in ascending sequence and writes then on another tape, five records per block. To execute the Tape Sort/Merge sample problem the following job control cards are needed:

```
// JOB SORT
// PAUSE ASSGN SYS002 TO SAME TAPE DRIVE AS IN PREVIOUS JOB
// ASSGN SYS002,X'cuu'
// PAUSE ASSGN SYS001,SYS003,SYS004,SYS005 TO DIFF TAPES
// ASSGN SYS001,X'cuu'
// ASSGN SYS003,X'cuu'
// ASSGN SYS004,X'cuu'
// ASSGN SYS005,X'cuu'
// EXEC TSRT
  S/M CONTROL CARDS (6 cards)
/*
/ε
```

SYSLOG output is shown in Figure 17.

The following list summarizes the SYSLSLST output shown in Figure 27.

- Job control cards
- Sort control cards
- Sort parameters
- Computed constants

```

// JOB SORT
// PAUSE // ASSIGN SYS002 TO SAME TAPE DRIVE AS IN PREVIOUS JOB
// ASSIGN SYS002,X*180*
// PAUSE // ASSIGN SYS001///SYS003///SYS004///SYS005 TO DIFF TAPES
// ASSIGN SYS001,X*180*
// ASSIGN SYS002,X*180*
// ASSIGN SYS004,X*180*
// ASSIGN SYS005,X*180*
// EXEC ISRT

-----

71011          **TAPE AND DISK OPERATING SYSTEM SORT/MERGE PROGRAM**

71007          **CONTROL CARD TESTING **

**CONTROL CARD 01 SORT      FORMAT=01, FIELDS=(1,2,3,4) MARKS 5
**CONTROL CARD 02 RECORD   TYPE=F, LENGTH=15
**CONTROL CARD 03 INPFIL   VOLUME=1, LENGTH=1 (1,5), OPEN=RWD
**CONTROL CARD 04 OUTFIL   BLKSIZE=75, CLOSE=FWD
**CONTROL CARD 05 OPTION   PRINT, LABEL=U, U, U
**CONTROL CARD 06 END

71001          **SORT PARAMETERS**

INPUT 1 VOLUME IS      1      THE OUTPUT BLOCKSIZE IS  75      THE INPUT BLOCKSIZE IS  15
INPUT BLOCK FORMAT IS  X      OPEN INPUT FILE           RWD      CLOSE OUTPUT FILE     FWD
THE RECORD TYPE IS    F      THE RECORD LENGTH 1 IS  15
THE OI OF LOCATION IS 12     THE OI OF LENGTH IS  4      THE OI OF SEQUENCE IS  A
WORK DRIVES AVAILABLE 3      THE DATA FORMAT IS  BI     INPUT LABELS ARE      U
WORK LABELS ARE       U      OUTPUT LABELS ARE      U

71001 **COMPUTED CONSTANTS**
MFS = 1471025
BLZ = 0010875
N   = 0000005
U   = 0001750
A   = 0000002

71001 ** END OF ASSIGNMENT PHASE **

-----

END SORT

```

Figure 27. SYSLST Output for Tape Sort/Merge Sample Problems

Tape-to-Printer Utility

Program Name is Z.UTTPR1. The Tape-to-Printer Utility sample problem lists the numbers handled by the assembler 1 and tape sort/merge sample problems, allowing the user to check for proper functioning of all three programs. To execute the tape to printer utility sample problem, the following job control cards are needed:

```
// JOB TPRR
// PAUSE ASSGN SYS004 TO SYS001 OF PREVIOUS JOB
// ASSGN SYS004,X'cuu'
// PAUSE ASSGN SYS005 TO THE PRINTER
// ASSGN SYS005,X'cuu'
// UPSI 1000
// EXEC TPRR
  T-P CONTROL CARDS (2 cards)
/*
/ε
```

The user must reply 1T IS EOF to the logged message by entering ⓑ (alternate code 5) from the IBM 1052 printer-keyboard.

SYSLOG output is shown in Figure 17.

A summary of the SYSIST output shown in Figure 28 follows:

- Job control cards
- Tape-to-printer control cards
- Utility parameter statements (11 lines)
- Numbers 0001-2000 (400 lines)
- IS IT EOF
- REPLY Y (ⓑ is not printed)
- END OF DATA
- NUMBER OF INPUT BLOCKS PROCESSED 000400
- NUMBER OF OUTPUT BLOCKS PROCESSED 000400
- END OF JOB

```

// JOB TPRR
// PAUSE // ASSGN SYS004 TO SYSGCI OF PREVIOUS JOB
// ASSGN SYS004,X*103*
// PAUSE // ASSGN SYS005 TO THE PRINTER
// ASSGN SYS005,X*00E*
// UPSE 1000
// EXEC TPRR

```

```

// UTP TL,FF,A=(75,75),B=(120),IR,GC,S1,PY
// END
$4620001
$4620002
TAPE TO PRINT UTILITY
INPUT RECORD LENGTH 0075
OUTPUT RECORD LENGTH 0120
INPUT BLOCK LENGTH 00075
OUTPUT BLOCK LENGTH 00120
INPUT OPTION REWIND
OUTPUT OPTION PRINT CHARACTER
2 INPUT,2 OUTPUT AREAS ASSIGNED
RECORD FORMAT FIXED
TYPE LIST
STARTING RECORD NUMBER 00000001

```

0001	0002	0003	0004	0005
0006	0007	0008	0009	0010
0011	0012	0013	0014	0015
0016	0017	0018	0019	0020
0021	0022	0023	0024	0025
0026	0027	0028	0029	0030
0031	0032	0033	0034	0035
0036	0037	0038	0039	0040
0041	0042	0043	0044	0045
0046	0047	0048	0049	0050
0051	0052	0053	0054	0055
0056	0057	0058	0059	0060
0061	0062	0063	0064	0065
0066	0067	0068	0069	0070
0071	0072	0073	0074	0075
0076	0077	0078	0079	0080
0081	0082	0083	0084	0085
0086	0087	0088	0089	0090
0091	0092	0093	0094	0095
0096	0097	0098	0099	0100
0101	0102	0103	0104	0105
0106	0107	0108	0109	0110
0111	0112	0113	0114	0115
0116	0117	0118	0119	0120
0121	0122	0123	0124	0125
0126	0127	0128	0129	0130
0131	0132	0133	0134	0135
0136	0137	0138	0139	0140
0141	0142	0143	0144	0145
0146	0147	0148	0149	0150
0151	0152	0153	0154	0155
0156	0157	0158	0159	0160
0161	0162	0163	0164	0165
0166	0167	0168	0169	0170
0171	0172	0173	0174	0175
0176	0177	0178	0179	0180
0181	0182	0183	0184	0185
0186	0187	0188	0189	0190

1911	1912	1913	1914	1915
1916	1917	1918	1919	1920
1921	1922	1923	1924	1925
1926	1927	1928	1929	1930
1931	1932	1933	1934	1935
1936	1937	1938	1939	1940
1941	1942	1943	1944	1945
1946	1947	1948	1949	1950
1951	1952	1953	1954	1955
1956	1957	1958	1959	1960

Figure 28. SYSLST Output for TP-PR Sample Problems (Part 1 of 2)

```
1961      1962      1963      1964      1965
1966      1967      1968      1969      1970
1971      1972      1973      1974      1975
1976      1977      1978      1979      1980
1981      1982      1983      1984      1985
1986      1987      1988      1989      1990
1991      1992      1993      1994      1995
1996      1997      1998      1999      2000

80010 IS IT EOF
REPLY Y
END OF DATA

NUMBER OF INPUT BLOCKS PROCESSED C00400
NUMBER OF OUTPUT BLOCKS PROCESSED C00400
END OF JOB

EQJ TPRR
```

Figure 28. SYSLST Output for TP-PR Sample Problems (Part 2 of 2)

Assembler 2

Program Name is Z.AS2. The Assembler 2 sample problem generates numbers from 2000 to 0002 in descending order and writes them on disk. To execute the Assembler 2 sample problem, the following job control cards are needed:

```

// JOB ASSEMBLE SAMPLE 2
// OPTION LINK,LIST,LOG,NOXREF
// EXEC ASSEMBLY
// ASSEMBLER SOURCE DECK (23 cards)
/*
// EXEC LNKEDT
// PAUSE ASSGN SYS002 to SCRATCH PACK
// ASSGN SYS002,X'cuu'
// VOL SYS002,OUTFILE
// DLAB 'SAMPLE PROBLEM FILE OF 2000 RECORDS      1hhhhhh',    C
// XTENT 1,000,000180000,000184002,'hhhhh',SYS002

Note:  Replace hhhhhh in the DLAB and XTENT cards with the volume serial
       number of the disk pack.

// EXEC
/£
```

SYSLOG output is shown in Figure 17.

The following list summarizes the SYSLST output shown in Figure 29:

- Job control cards
- External symbol dictionary
- Source program listing
- Relocation dictionary
- Linkage editor storage map

```
// JOB ASSEMBLE SAMPLE 2
// CPTIUN LINK,LIST,LOG,NUXREF
// EXEC ASSEMBLY
```

```
EXTERNAL SYMBOL DICTIONARY

SYMBOL TYPE ID ADDR LENGTH LU ID

      PC 01 0000C 00017C
1J6FUZZZ BK 02
1J6FUZZZ SD 03 00018C 00020C
```

DDS ASSEMBLER TEST

LOC	OBJECT CODE	ADDR1	ADDR2	STMT	SOURCE STATEMENT	DDS CL3-0
				2	PRINT NUGEN	\$4650102
000000				3	START 0	\$4650103
000000	0580			4	TESTGEN BALR 8,0	\$4650104
000002				5	USING *98	\$4650105
000002	4100 811E		00120	6	LA 13,SAVEAREA	\$4650106
				7	OPEN OUTFILE	\$4650107
000010	4130 0700		00700	15	LA 3,2000	\$4650108
00001A	4E30 8116		00118	16	NEXT LVD 3,0000	\$4650109
00001E	F337 2008 8116 00005		00118	17	UNPK 11(4,2),0000	\$4650110
000024	96FC 200E		0000E	18	UI 14(2),X*FO*	\$4650111
				19	PUT OUTFILE	\$4650112
000034	4630 8018		0001A	24	BCT 3,NEXT	\$4650113
				25	CLOSE OUTFILE	\$4650114
				33	EIJ	\$4650115
				36	OUTFILE UTFSD BLKSIZE=23,LUAREA1=A1,LUAREA2=A2,TYPEFLD=OUTPUT,LUAREA3=A3,RECFORM=FIXED,DEVICE=2311	\$4650116
				85	SUMUDFD	\$4650117
0000E8	4C40404040404040			264	A1 DC 23C' *	\$4650118
0000FF	4C40404040404040			265	A2 DC 23C' *	\$4650119
000118				266	DWD US U	\$4650120
000120				267	SAVEAREA DS 50	\$4650121
000000				268	END TESTGEN	\$4650122
000108	5B5B206D7C5D54C			269	=C'\$\$OPEN'	
000170	5B5B206D7C5D54C			270	=C'\$\$CLOSE'	
000178	0000048			271	=A(OUTFILE)	

Figure 29. SYSLST Output for Assembler (AS2) Sample Problems (Part 1 of 2)

```

                                RELOCATION DICTIONARY

POS.ID  REL.ID  FLAGS  ADDRESS
01      01      0C      000010
01      01      0C      000040
01      01      0C      000050
01      02      1B      000059
01      01      08      000071
01      01      0C      000074
01      01      0C      0000A0
01      01      0C      0000A8
01      01      08      0000B1
01      01      08      0000B9
01      01      08      0000C1
01      01      08      0000C9
01      01      08      000001
01      01      08      000009
01      01      08      0000E1
01      01      0C      000178

NO STATEMENTS FLAGGED IN THIS ASSEMBLY

// EXEC LINKEDT

JOB  ASSEMBLE          DISK LINKAGE EDITOR DIAGNOSTIC OF INPUT
ACTION TAKEN  MAP
LIST  ENTRY

      PHASE  XFR-AD  LOGCORE  HICORE  DSK-AD  ESD TYPE  LABEL      LOADED  REL-FR
PHASE***  002000  002000  002388  22 1 2  CSECT      '002000  002000
                                CSECT      IJGFOZZZ  002180  002000

// PAUSE // ASSGN SYS002 TO SCRATCH PACK
// ASSGN SYS002, X*291*
// VOL SYS002,OUTFILE
// DLAB 'SAMPLE PROBLEM FILE OF 2000 RECORDS      1111111',      C
//          0001,66080,66080,' SAMPLE TEST '
// XTENT 1,000,000180000,000184002,*111111',SYS002
// EXEC

EOJ ASSEMBLE

```

Figure 29. SYSLST Output for Assembler (AS2) Sample Problems (Part 2 of 2)

Disk Sort/Merge

Program Name is Z.SM2. The disk sort/merge sample problem rearranges in ascending sequence the numbers generated by the Assembler 2 problem. To execute the disk sort/merge sample problem the following job control cards are needed:

```

// JOB DSORT
// PAUSE ASSGN SYS002 AND SYS004 to SCRATCH PACK
// ASSGN SYS002,X'cuu'
// ASSGN SYS004,X'cuu'
// VOL SYS002,FILEA
// DLAB 'SAMPLE PROBLEM FILE OF 2000 RECORDS      1hhhhh',    C
//          Col. 16
//          0001,66080,66080,' SAMPLE TEST '
// XTENT 1,000,000180000,000184002,'hhhhh',SYS002
// VOL SYS002,FILEW
// DLAB 'SAMPLE PROBLEM WORK AREA FOR SORT RUN    1hhhhh',    C
//          Col. 16
//          0001,66080,66080,' SAMPLE TEST ',DA
// XTENT 1,000,000184003,000186005,'hhhhh',SYS002
// VOL SYS004,FILEO
// DLAB 'SORTED FILE OF 2000 RECORDS FOR UTILITIES 1hhhhh',    C
//          Col. 16
//          0001,66080,66080,' SAMPLE TEST '
// XTENT 1,000,000180000,000184002,'hhhhh',SYS004
```



Note: Replace hhhhhh in the DLAB and XTENT cards with the volume serial number of the disk pack.

```
// EXEC DSORT
S/M CONTROL CARDS (6 cards)
/*
/ε
```

SYSLOG output is shown in Figure 17.

The following list summarizes the SYSLST output shown in Figure 30:

- Job control cards
- Sort control cards
- Sort parameters
- Computed constants

```

// JOB DSURT
// PAUSE // ASSGN SYS002 AND SYS004 TO SCRATCH PALK
// ASSGN SYS002,X'291'
// ASSGN SYS004,X'291'
// VOL SYS002,FILEA
// DLAB *SAMPLE PROBLEM FILE OF 2000 RECORDS          1111111',      C
//          0001,66080,66080,* SAMPLE TEST '
// XTENT 1,000,000180000,000184002,*111111',SYS002
// VOL SYS002,FILEA
// DLAB *SAMPLE PROBLEM WORK AREA FOR SORT RUN          1111111',      C
//          0001,66080,66080,* SAMPLE TEST ',DA
// XTENT 1,000,000184003,000186005,*111111',SYS002
// VOL SYS004,FILEA
// DLAB *SORTED FILE OF 2000 RECORDS FOR UTILITIES     1111111',      C
//          0001,66080,66080,* SAMPLE TEST '
// XTENT 1,000,000180000,000184002,*111111',SYS004
// EXEC DSURT

```

```

70631      ** JOB DSURT      **      *** CONTROL CARD INFORMATION ***      ** 01/01/68 **

          *** CONTROL CARDS ***

SORT FIELDS=(12,4,A),FORMAT=BI,SIZE=2000                $4500001
RECORD TYPE=F,LENGTH=(15,,15)                          $4500002
INPFIL BLKSIZE=(15,X),INPUT=D                          $4500003
GUTFIL BLKSIZE=75,OUTPUT=D                             $4500004
OPTION PRINT,LABEL=(S,S)                               $4500005
END                                                       $4500006

SORT FIELD      C1      LOCATION 0012 LENGTH 004 SEQUENCE A FORMAT BI FILES 1 SIZE 00002000
RECORD TYPE FIXED LENGTH 1 0015 LENGTH 2 NONE LENGTH 3 0015
INPUT BLOCKSIZE 00015 TYPE FIXED
INPUT FILEA
TYPE DISK
LABELS STD
OUTPUT BLOCKSIZE 00075 LABEL STD TYPE DISK

OPTIONS SPECIFIED

OPTION 01 PRINT
OPTION 02 STORAGE 00065536

          *** COMPUTED CONSTANTS ***

70571 MAXIMUM FILE SIZE 00002410
70581 NUMBER OF FILE TRACKS SPECIFIED 00023
70601 OUTPUT BLOCKS PER TRACK 26
70611 SORT/MERGE PROGRAM ORIGIN 08192
70651 3615 MAXIMUM B3.
70651 3615 MAXIMUM B1.

```

```

EUJ DSURT

```

```

```

Figure 30. SYSLST Output for Disk Sort/Merge Sample Problems

Disk-to-Printer Utility

Program Name is Z.UTDKPR1. The disk-to-printer utility sample problem lists the numbers handled by the Assembler 2 and disk sort/merge sample problems. To execute the disk-to-printer utility sample problem, the following job control cards are needed:

```

                                         Col. 54      Col. 72
                                         ↓           ↓
// JOB DKPR
// PAUSE ASSGN SYS004 TO SCRATCH PACK
// ASSGN SYS004,X'cuu'
// PAUSE ASSGN SYS005 TO THE PRINTER
// ASSGN SYS005,X'cuu'
// UPSI 0000
// VOL SYS004, UIN
// DLAB 'SORTED FILE OF 2000 RECORDS FOR UTILITIES 1hhhhh', C
           Col. 16
           0001,66080,66080,' SAMPLE TEST '
// XTENT 1,000,000180000,000184002,'hhhhh',SYS004
```

Note: Replace hhhhhh in the DLAB and XTENT cards with the volume serial number of the disk pack.

```
// EXEC DKPR
   D-P CONTROL CARDS (2 cards)
/*
/ &
```

SYSLOG output is shown in Figure 17.

The following list summarizes the SYSLST output shown in Figure 31 :

- Job control cards
- Disk-to-printer control cards
- Utility parameter statements (10 lines)
- Numbers 0001-2000 (400 lines)
- NUMBER OF INPUT BLOCKS PROCESSED 000400
- NUMBER OF OUTPUT BLOCKS PROCESSED 000400
- END OF JOB

```

// JOB DKPR
// PAUSE // ASSGN SYS004 TO SCRATCH PACK
// ASSGN SYS004,X'291'
// PAUSE // ASSGN SYS005 TO THE PRINTER
// ASSGN SYS005,X'00E'
// UPSI 0000
// VOL SYS004,UIIN
// DLAB *SORTED FILE OF 2000 RECURS FOR UTILITIES 111111', C
// XTENT 1,000,0001800C0,00018400Z,'111111',SYS004
// EXEC DKPR

```

```

// UDP TL,FF,A=(75,75),B=(120),GC,S1,PY $4610001
// END $4610002
LIST TO PRINT UTILITY
INPUT RECORD LENGTH 0075
OUTPUT RECORD LENGTH 0120
INPUT BLCK LENGTH 00075
OUTPUT BLCK LENGTH 00120
OUTPUT OPTION PRINT CHARACTER
2 INPUT,2 OUTPUT AREAS ASSIGNED
RECORD FORMAT FIXED
TYPE LIST
STARTING RECORD NUMBER 00000001
INPUT DEVICE TYPE 2311

```

0001	0002	0003	0004	0005
0006	0007	0008	0009	0010
0011	0012	0013	0014	0015
0016	0017	0018	0019	0020
0021	0022	0023	0024	0025
0026	0027	0028	0029	0030
0031	0032	0033	0034	0035
0036	0037	0038	0039	0040
0041	0042	0043	0044	0045
0046	0047	0048	0049	0050
0051	0052	0053	0054	0055
0056	0057	0058	0059	0060
0061	0062	0063	0064	0065
0066	0067	0068	0069	0070
0071	0072	0073	0074	0075
0076	0077	0078	0079	0080
0081	0082	0083	0084	0085
0086	0087	0088	0089	0090
0091	0092	0093	0094	0095
0096	0097	0098	0099	0100
0101	0102	0103	0104	0105
0106	0107	0108	0109	0110
0111	0112	0113	0114	0115
0116	0117	0118	0119	0120
0121	0122	0123	0124	0125
0126	0127	0128	0129	0130
0131	0132	0133	0134	0135
0136	0137	0138	0139	0140
0141	0142	0143	0144	0145
0146	0147	0148	0149	0150
0151	0152	0153	0154	0155
0156	0157	0158	0159	0160
0161	0162	0163	0164	0165
0166	0167	0168	0169	0170
0171	0172	0173	0174	0175
0176	0177	0178	0179	0180
0181	0182	0183	0184	0185
0186	0187	0188	0189	0190
0191	0192	0193	0194	0195
0196	0197	0198	0199	0200
0201	0202	0203	0204	0205
0206	0207	0208	0209	0210
0211	0212	0213	0214	0215
0216	0217	0218	0219	0220
0221	0222	0223	0224	0225
0226	0227	0228	0229	0230
0231	0232	0233	0234	0235
0236	0237	0238	0239	0240
0241	0242	0243	0244	0245
0246	0247	0248	0249	0250
0251	0252	0253	0254	0255
0256	0257	0258	0259	0260
0261	0262	0263	0264	0265
0266	0267	0268	0269	0270

Figure 31. SYSLST Output for DK-PR Sample Problems (Part 1 of 2)

1866	1867	1868	1869	1870
1871	1872	1873	1874	1875
1876	1877	1878	1879	1880
1881	1882	1883	1884	1885
1886	1887	1888	1889	1890
1891	1892	1893	1894	1895
1896	1897	1898	1899	1900
1901	1902	1903	1904	1905
1906	1907	1908	1909	1910
1911	1912	1913	1914	1915
1916	1917	1918	1919	1920
1921	1922	1923	1924	1925
1926	1927	1928	1929	1930
1931	1932	1933	1934	1935
1936	1937	1938	1939	1940
1941	1942	1943	1944	1945
1946	1947	1948	1949	1950

1951	1952	1953	1954	1955
1956	1957	1958	1959	1960
1961	1962	1963	1964	1965
1966	1967	1968	1969	1970
1971	1972	1973	1974	1975
1976	1977	1978	1979	1980
1981	1982	1983	1984	1985
1986	1987	1988	1989	1990
1991	1992	1993	1994	1995
1996	1997	1998	1999	2000
END OF DATA				

NUMBER OF INPUT BLOCKS PROCESSED 000400				
NUMBER OF OUTPUT BLOCKS PROCESSED 000400				
END OF JOB				

EDJ DKPR				

Figure 31. SYSIST Output for DK-PR Sample Problems (Part 2 of 2)

Assembler 3

Program Name is Z.AS3. The Assembler 3 sample problem generates numbers from 100 to 001, in descending order, and writes them on a data cell. To execute the Assembler 3 sample problem the following job control cards are needed:

```

// JOB ASSEMBLE SAMPLE 3
// OPTION LINK,LIST,LOG,NOXREF
// EXEC ASSEMBLY
// ASSEMBLER SOURCE DECK (23 cards)
/*
// EXEC LNKEDT
// PAUSE ASSGN SYS004 TO DATA CELL
// ASSGN SYS004,X'cuu'
// VOL SYS004,OUTFILE
// DLAB 'SAMPLE PROBLEM FILE OF 100 RECORDS          1hhhhhh',    C
// XTENT 1,0,310002000,310001019,'hhhhhh',SYS004

Note:  Replace hhhhhh in the DLAB and XTENT cards with the volume serial
       number of the data cell.

// PAUSE MOUNT CELL hhhhhh ON STATION 3
// EXEC
/;&
```

SYSLOG output is shown in Figure 17.

The following list summarizes the SYSLST output shown in Figure 32:

- Job control cards
- External symbol dictionary
- Source program listing
- Relocation dictionary
- Linkage editor storage map

```
// JOB ASSEMBLE SAMPLE 3
// OPTIGN LINK,LIST,LOG,NUXREF
// EXEC ASSEMBLY
```

EXTERNAL SYMBOL DICTIONARY

SYMBGL	TYPE	ID	ADDR	LENGTH	LD	ID
	PC	01	000000	00C17C		
1JGFDZZ	ER	02				
1JGFUZZ	SD	G3	0G018C	G0020C		

DOS ASSEMBLER TEST

LOC	OBJECT CODE	ADDK1	AUDR2	STMT	SOURCE STATEMENT	DOS CL3-0
				2	PRINT NUGEN	\$4650202
000000				3	START 0	\$4650203
000000	0580			4	WALR 8,0 LOAD THE BASE REGISTER.	\$4650204
000002				5	USING *8	\$4650205
000002	41D0 811E		00120	6	LA 13,SAVEAREA	\$4650206
				7	OPEN OUTFILE	\$4650207
000016	4130 0064		00064	15	LA 3,100 GET STARTING RECORD VALUE.	\$4650208
00001A	4E30 8116		00118	16	NEXT CVD 3,DWD CONVERT THE VALUE TO DECIMAL.	\$4650209
00001E	F337 200B 8116	0000B	00118	17	UNPK 11(4,2),DWD UNPACK THE VALUE.	\$4650210
000024	96FG 200E		0000E	18	OI 14(2),X'F0' MASK THE SIGN BIT.	\$4650211
				19	PJT OUTFILE WRITE A RECORD ON THE DATA CELL.	\$4650212
000034	4630 8018		0001A	24	BCT 3,NEXT TEST FOR TASK COMPLETE.	\$4650213
				25	CLUSE OUTFILE CLOSE THE DATA CELL FILE.	\$4650214
				33	EOJ RETURN TO THE CONTROL PROGRAM.	\$4650215
				36	OUTFILE DTFSD BLKSIZE=23,IOAREA1=A1,IOAREA2=A2,TYPEFL=OUTPUT, IUREG=(2),RECFM=FIXUNB,DEVICE=2321,VERIFY=YES	\$4650216
				85	SDMUDFD	\$4650217
0000E8	4C40404040404040			264	A1 UC 23C' '	\$4650218
0000FF	4040404040404040			265	A2 DC 23C' '	\$4650219
000118				266	DWD US 0	\$4650220
000120				267	SAVEAREA DS 9D	\$4650221
000000				268	END TESTGEN	\$4650222
000168	5B5H C2D6D7C5D540			269	=C'\$\$BOPEN'	\$4650223
000170	5H5HC2C3D3D6E2C5			270	=C'\$\$CLUSE'	
000178	CC0G048			271	=A(OUTFILE)	

RELOCATION DICTIONARY

POS.ID	REL.ID	FLAGS	ADDRESS
01	01	0C	000010
01	01	0C	000040
01	01	0C	000050
01	02	18	000059
01	01	08	000071
01	01	0C	000074
01	01	0C	0000A0
01	01	0C	0000AB
01	01	08	0000B1
01	01	08	0000B9
01	01	08	0000C1
01	01	08	0000C9
01	01	08	0000D1
01	01	08	0000D9
01	01	08	0000E1
01	01	0C	000178

NO STATEMENTS FLAGGED IN THIS ASSEMBLY

Figure 32. SYSLST Output for Assembler (AS3) Sample Problems (Part 1 of 2)

```

// EXEC LNKEDT

JOB ASSEMBLE          DISK LINKAGE EDITOR DIAGNOSTIC OF INPUT
ACTION TAKEN  MAP
LIST  ENTRY

PHASE  XFR-AD  LOGCORE  HICORE  OSK-AD  ESD TYPE  LABEL      LOADED  REL-FR
PHASE** 002000  002000  002388  1E 5 2  CSECT          002000  002000
                                CSECT    IJGF0ZZZ  002180  002000

// PAUSE // ASSGN SYS004 TO DATA CELL
// ASSGN SYS004,X*292*
// VOL SYS004,OUTFILE
// OLAB *SAMPLE PROBLEM FILE OF 100 RECORDS          1111111', C
//          0001,66080,66080,' SAMPLE TEST '
// XTENT 1,0,310001000,310001019,'111111',SYS004
// PAUSE MOUNT CELL 111111 ON STATION 3
// EXEC

EOJ ASSEMBLE

```

Figure 32. SYSLST Output for Assembler (AS3) Sample Problems (Part 2 of 2)

Data Cell-to-Printer

Program Name is Z.UTDCPR1. The data cell-to-printer sample problem lists the numbers that the Assembler 3 sample problem wrote on the data cell. To execute the data cell-to-printer sample problem the following job control cards are needed:

```

// JOB DCPR
// PAUSE ASSGN SYS004 TO DATA CELL
// ASSGN SYS004,X'cuu'
// PAUSE ASSGN SYS005 TO THE PRINTER
// ASSGN SYS005,X'cuu'
// UPSI 0000
// VOL SYS004,UIN
// DLAB 'SAMPLE PROBLEM FILE OF 100 RECORDS      1hhhhh',      C
//          Col. 16
//          0001,66080,66090,' SAMPLE TEST '
// XTENT 1,0,310001000,310001019,'hhhhh',SYS004
```

Col. 54 Col. 72
↓ ↓

Note: Replace hhhhhh in the DLAB and XTENT cards with the volume serial number of the data cell.

```
// EXEC DCPR
DC-P CONTROL CARDS (2 cards)
/*
/ε
```

SYSIOG output is shown in Figure 17.

The following list summarizes the SYSLST output shown in Figure 33:

- Job control cards
- Data cell-to-printer control cards
- Utility parameter statements (10 lines)
- Number 0100-0001 (100 lines)
- NUMBER OF INPUT BLOCKS PROCESSED 000100
- NUMBER OF OUTPUT BLOCKS PROCESSED 000100
- END OF JOB

```

// Job DCPR
// PAUSE // ASSIGN SYS004 TO DATA CELL
// ASSIGN SYS004,X'292'
// PAUSE // ASSIGN SYS005 TO THE PRINTER
// ASSIGN SYS005,X'00E'
// UPSI C000
// VUL SYS004,UIN
// DLAB *SAMPLE PROBLEM FILE OF 100 RECORDS      1111111',      C
//          0001,66080,66080,' SAMPLE TEST '
// XTENT 1,0,310001000,310001019,'1111111',SYS004
// EXEC DCPR

// UMP IL,FF,A=(15,15),B=(120),S1,PY              $4630001
// END                                             $4630002
DATA CELL TO PRINT UTILITY
INPUT RECORD LENGTH 0015
OUTPUT RECORD LENGTH 0120
INPUT BLOCK LENGTH 00015
OUTPUT BLOCK LENGTH 00120
OUTPUT CPTJUN PRINT CHARACTER
Z INPUT,Z OUTPUT AREAS ASSIGNED
RECORD FORMAT FIXED
TYPE LIST
STACKING RECORD NUMBER 00000001
INPUT DEVICE TYPE 2321

0100
0099
0098
0097
0096
0095
0094
0093
0092
0091
0090
0089
0088
0087
0086
0085
0084
0083
0082
0081
0080
0079
0078
0077
0076
0075
0074
0073
0072
0071
0070
0069
0068
0067
0066
0065
0064
0063
0062
0061

```

Figure 33. SYSLST Output for DC-PR Sample Problems (Part 1 of 2)

```

G015
G014
G013
G012
G011
G010
G009
G008
G007
G006
G005
G004
G003
G002
G001
END OF DATA

NUMBER OF INPUT BLOCKS PROCESSED 000100
NUMBER OF OUTPUT BLOCKS PROCESSED 000100
END OF JOB

E0J DCPK
```

Figure 33. SYSLST Output for DC-PR Sample Problems (Part 2 of 2)

Assembler 4

Program Name is Z.AS4. The Assembler 4 sample problem generates numbers from 2000 to 0001 in descending order and writes them on tape as 15 character unblocked records (11 blanks followed by 4 zoned digits, unsigned). To execute the Assembler 4 sample problem the following job control cards are needed:

```
// JOB ASSEMBLY SAMPLE 4
// OPTION LINK,LIST,LOG,NOXREF
// EXEC ASSEMBLY
    Assembler source deck (23 cards)
/*
// EXEC INKEDT
// PAUSE ASSGN SYS002 TO A 9 TRACK TAPE DRIVE
// ASSGN SYS002,X'cuu'
// MTC REW,SYS002
// EXEC
/ε
```

SYSLOG output is shown in Figure 17.

The following list summarizes the SYSLST output shown in Figure 34:

- Job control cards
- External symbol dictionary
- Source program listing
- Relocation dictionary
- Linkage editor storage map

```
// JOB ASSEMBLY SAMPLE 4
// OPTION LINK,LIST,LOG,NGXREF
// EXEC ASSEMBLY
```

EXTERNAL SYMBOL DICTIONARY

PAGE 1

```
SYMBOL TYPE ID ADDR LENGTH LD ID
PC 01 000000 00012C
IJFFZZZZ ER 02
IJFFZZZZ SD 03 00013C 0002D2
```

SMPL DOS ASSEMBLER TEST

PAGE 1

UOS CL3-1 01/01/61

LOC	OBJECT CODE	ADDR1	ADDR2	STMT	SOURCE STATEMENT	
				2	PRINT NGXEN	\$4650402
000000				3	START J	\$4650403
000000	0580			4	TESTGEN BALR 8,C	\$4650404
000002				5	USING *,8	\$4650405
000002	4100 800E		0000C	6	LA 13,SAVEAREA	\$4650406
				7	OPEN OUTFILE	\$4650407
000016	4130 0700		CC700	15	LA 3,2000	\$4650408
00001A	4E30 80C6		00008	16	NEXT CVD 3,DWD	\$4650409
00001E	F337 200B 80C6 0000B		00008	17	UNPK 11(4,2),DWD	\$4650410
000024	96F0 200E		0000E	18	UI 14(2),X*FD*	\$4650411
				19	PUI OUTFILE	\$4650412
000034	4630 8018		0001A	24	BCT 3,NEXT	\$4650413
				25	CLUSE OUTFILE	\$4650414
				33	EOJ	\$4650415
				36	OUTFILE DTFTM BLKSIZE=18,DEVADDR=SYS002,FILEBL=NG,ISAREAL=A1,IOAREAZ=A2,IUREG={2},TYPEFLE=OUTPUT	\$4650416
				67	MTMDD RECFORM=FIXUNB	\$4650418
00009E	4040404040404040			295	A1 DC 18C*	\$4650419
0000B0	4040404040404040			296	A2 DC 18C*	\$4650420
0000C8				297	DWD DS D	\$4650421
0000D0				298	SAVEAREA DS 9D	\$4650422
000000				299	END TESTGEN	\$4650423
000118	5B5BC2D6D7C5D540			300	=C* \$\$BUPEN *	
000120	5B5BC2C3D3D6E2C5			301	=C* \$\$BCLOSE*	
000128	0C000048			302	=A(OUTFILE)	

RELOCATION DICTIONARY

PAGE 1

POS.ID	REL.ID	FLAGS	ADDRESS
01	01	0C	000010
01	01	0C	000040
01	01	0C	000050
01	02	18	000059
01	01	08	000060
01	01	08	000081
01	01	0C	000088
01	01	0C	00008C
01	01	0C	000094
01	01	0C	000128

NO STATEMENTS FLAGGED IN THIS ASSEMBLY

// EXEC LNKEDT

Figure 34. SYSLST Output for Assembler (AS4) Sample Problems (Part 1 of 2)

```

JOB ASSEMBLY          DISK LINKAGE EDITOR DIAGNOSTIC OF INPUT
ACTION TAKEN          MAP
LIST   ENTRY

01/01/01  PHASE  XFR-AD  LOGRE  HICORE  USK-AD  ESD TYPE  LABEL    LOAUED  REL-FR
          PHASE*** 002800 002800 002C01 28 06 2  CSECT    002800 002800
                                   CSECT    1JFF2222 002930 002800

// PAUSE ASSGN SYS002 TO A 9 TRACK TAPE DRIVE
// ASSGN SYS002,X*282*
// HTC REM,SYS002
// EXEC

EQJ ASSEMBLY

```

Figure 34. SYSLIST Output for Assembler (AS4) Sample Problems (Part 2 of 2)

Tape and Disk Sort/Merge -- 2400 Application

Program Name is Z.SM4. The Tape and Disk Sort/Merge sample problem rearranges in ascending sequence the records produced by the Assembler 4 program and writes them on another tape, five records per block. To execute the Tape and Disk Sort/Merge sample problem the following job control cards are needed:

```
// JOB SORT 2400
// PAUSE ASSGN SYS002 TO SAME DRIVE AS PREVIOUS JOB
// PAUSE ASSGN SYS001,SYS003,SYS004,SYS005 TO DIFF TAPES
// ASSGN SYS001,X'cuu'
// ASSGN SYS002,X'cuu'
// ASSGN SYS003,X'cuu'
// ASSGN SYS004,X'cuu'
// ASSGN SYS005,X'cuu'
// TLBL SORTOUT,,64/001
// TLBL SORTIN1,,64/001
// TLBL SORTWK1,,64/001
// TLBL SORTWK2,,64/001
// TLBL SORTWK3,,64/001
// IBITYP TAPE
// EXEC SORT
Sort/merge control cards (6 cards)
/£
```

SYSLOG output is shown in Figure 17.

The following list summarizes the SYSLST output shown in Figure 35.

- Job control cards
- Sort control cards
- Sort parameters
- Computed constants

```

// JOB SORT 2400
// PAUSE ASSIGN SYS002 TO SAME DRIVE AS PREVIOUS JOB
// PAUSE ASSIGN SYS001, SYS003, SYS004, SYS005 TO DIFF TAPES
// ASSIGN SYS001,X'280'
// ASSIGN SYS002,X'282'
// ASSIGN SYS003,X'287'
// ASSIGN SYS004,X'284'
// ASSIGN SYS005,X'285'
// TLBL SORTOUT,64/001
// TLBL SORTIN1,64/001
// TLBL SORTWK1,64/001
// TLBL SORTWK2,64/001
// TLBL SORTWK3,64/001
// LBLTYP TAPE
// EXEC SORT

70001  SORT  FORMAT=BI, FIELDS=(12,4,A),WORK=3           $4830001
70001  RECCRD  TYPE=F,LENGTH=18                          $4830002
70001  OPTION  PRINT=ALL, LABEL=10,0,01                 $4830003
70001  INPR  IL  VOLUME=1, BLKSIZE=18                    $4830004
70001  OUTF  IL  BLKSIZE=90                               $4830005
70001  END
70501  NMAX=001144876
70511  B=      000009991
70521  G=      000006041
70011  PHASE 0 END,NO DETECTED ERRORS

```

```

EQU SORT

```

Figure 35. SYSLST Output for Tape and Disk Sort/Merge Sample Problem

Tape-to-Printer Utility

Program Name is Z.UTTPPR2. The Tape-to-Printer Utility sample problem lists the numbers handled by the Assembler 4 and tape and disk sort/merge (2400 application) sample programs. To execute the tape to printer utility sample problem, the following job control cards are needed:

```
// JOB TPPR 2400 TO PRINTER
// PAUSE ASSGN SYS004 TO SYS001 OF PREVIOUS JOB
// ASSGN SYS004,X'cuu'
// PAUSE ASSGN SYS005 TO THE PRINTER
// ASSGN SYS005,X'cuu'
// UPSI 1000
// EXEC TPPR
    Tape-to-printer utility control cards (2 cards)
/*
/ε
```

The user must reply IT IS EOF to the logged message by entering ⓑ (alternate code 5) from the IBM 1052 printer-keyboard.

SYSLOG output is shown in Figure 17.

The following list summarizes the SYSLST output shown in Figure 36:

- Job control cards
- Tape-to-printer control cards
- Utility parameter statements (11 lines)
- Numbers 0001-2000 (400 lines)
- IS IT EOF
- REPLY Y (ⓑ is not printed)
- END OF DATA
- NUMBER OF INPUT BLOCKS PROCESSED 000400
- NUMBER OF OUTPUT BLOCKS PROCESSED 000400
- END OF JOB

```

// JOB TPRR 2400 TU PRINTER
// PAUSE ASSGN SYSG04 TO SYS001 OF PREVIOUS JOB
// ASSGN SYSG04,X'286'
// PAUSE ASSGN SYSG05 TO THE PRINTER
// ASSGN SYSG05,X'00E'
// UPSI 1000
// EXEC TPRR

```

```

// UTP TL,FF,A=(9C,90),B=(144),IR,OC,S1,PY
// END
TAPE TO PRINT UTILITY
INPUT RECORL LENGTH 0090
OUTPUT RECORL LENGTH 0144
INPUT BLOCK LENGTH 00C90
OUTPUT BLOCK LENGTH 00144
INPUT OPTIUN REWIND
OUTPUT OPTIUN PRINT CHARACTER
2 INPUT,2 OUTPUT AREAS ASSIGNED
RECORL FORMAT FIXED
TYPE LIST
STARTING RECORD NUMBER 0000001

```

\$4630101
\$4630102

0001	0002	0003	0004	0005
0006	0007	0008	0009	0010
0011	0012	0013	0014	0015
0016	0017	0018	0019	0020
0021	0022	0023	0024	0025
0026	0027	0028	0029	0030
0031	0032	0033	0034	0035
0036	0037	0038	0039	0040
0041	0042	0043	0044	0045
0046	0047	0048	0049	0050
0051	0052	0053	0054	0055
0056	0057	0058	0059	0060
0061	0062	0063	0064	0065
0066	0067	0068	0069	0070
0071	0072	0073	0074	0075
0076	0077	0078	0079	0080
0081	0082	0083	0084	0085
0086	0087	0088	0089	0090
0091	0092	0093	0094	0095
0096	0097	0098	0099	0100
0101	0102	0103	0104	0105
0106	0107	0108	0109	0110
0111	0112	0113	0114	0115
0116	0117	0118	0119	0120
0121	0122	0123	0124	0125
0126	0127	0128	0129	0130
0131	0132	0133	0134	0135
0136	0137	0138	0139	0140
0141	0142	0143	0144	0145
0146	0147	0148	0149	0150
0151	0152	0153	0154	0155
0156	0157	0158	0159	0160
0161	0162	0163	0164	0165
0166	0167	0168	0169	0170
0171	0172	0173	0174	0175
0176	0177	0178	0179	0180
0181	0182	0183	0184	0185
0186	0187	0188	0189	0190
0191	0192	0193	0194	0195
0196	0197	0198	0199	0200
0201	0202	0203	0204	0205
0206	0207	0208	0209	0210
0211	0212	0213	0214	0215
0216	0217	0218	0219	0220
0221	0222	0223	0224	0225
0226	0227	0228	0229	0230
0231	0232	0233	0234	0235
0236	0237	0238	0239	0240
0241	0242	0243	0244	0245
0246	0247	0248	0249	0250
0251	0252	0253	0254	0255
0256	0257	0258	0259	0260
0261	0262	0263	0264	0265
0266	0267	0268	0269	0270
0271	0272	0273	0274	0275
0276	0277	0278	0279	0280

PAGE 1

Figure 36. SYSLST Output for Tape-to-Printer Sample Problems
(Part 1 of 4)

	0281	0282	0283	0284	0285
	0286	0287	0288	0289	0290
	0291	0292	0293	0294	0295
	0296	0297	0298	0299	0300
	0301	0302	0303	0304	0305
	0306	0307	0308	0309	0310
	0311	0312	0313	0314	0315
	0316	0317	0318	0319	0320
	0321	0322	0323	0324	0325
	0326	0327	0328	0329	0330
	0331	0332	0333	0334	0335
	0336	0337	0338	0339	0340
PAGE 2	0536	0537	0538	0539	0540
	0541	0542	0543	0544	0545
	0546	0547	0548	0549	0550
	0551	0552	0553	0554	0555
	0556	0557	0558	0559	0560
	0561	0562	0563	0564	0565
	0566	0567	0568	0569	0570
	0571	0572	0573	0574	0575
	0576	0577	0578	0579	0580
	0581	0582	0583	0584	0585
	0586	0587	0588	0589	0590
	0591	0592	0593	0594	0595
	0596	0597	0598	0599	0600
	0601	0602	0603	0604	0605
	0606	0607	0608	0609	0610
	0611	0612	0613	0614	0615
	0616	0617	0618	0619	0620
	0621	0622	0623	0624	0625
	0626	0627	0628	0629	0630
	0631	0632	0633	0634	0635
	0636	0637	0638	0639	0640
PAGE 3	0841	0842	0843	0844	0845
	0846	0847	0848	0849	0850
	0851	0852	0853	0854	0855
	0856	0857	0858	0859	0860
	0861	0862	0863	0864	0865
	0866	0867	0868	0869	0870
	0871	0872	0873	0874	0875
	0876	0877	0878	0879	0880
	0881	0882	0883	0884	0885
	0886	0887	0888	0889	0890
	0891	0892	0893	0894	0895
	0896	0897	0898	0899	0900
	0901	0902	0903	0904	0905
	0906	0907	0908	0909	0910
	0911	0912	0913	0914	0915
	0916	0917	0918	0919	0920
PAGE 4	1101	1102	1103	1104	1105
	1106	1107	1108	1109	1110
	1111	1112	1113	1114	1115
	1116	1117	1118	1119	1120

Figure 36. SYSIST Output for Tape-to-Printer Sample Problems (Part 2 of 4)

	1121	1122	1123	1124	1125
	1126	1127	1128	1129	1130
	1131	1132	1133	1134	1135
	1136	1137	1138	1139	1140
	1371	1372	1373	1374	1375
	1376	1377	1378	1379	1380
	1381	1382	1383	1384	1385
	1386	1387	1388	1389	1390
	1391	1392	1393	1394	1395
PAGE 5	1396	1397	1398	1399	1400
	1401	1402	1403	1404	1405
	1406	1407	1408	1409	1410
	1411	1412	1413	1414	1415
	1416	1417	1418	1419	1420
	1656	1657	1658	1659	1660
	1661	1662	1663	1664	1665
	1666	1667	1668	1669	1670
	1671	1672	1673	1674	1675
PAGE 6	1676	1677	1678	1679	1680
	1681	1682	1683	1684	1685
	1686	1687	1688	1689	1690
	1691	1692	1693	1694	1695
	1696	1697	1698	1699	1700
	1701	1702	1703	1704	1705
	1946	1947	1948	1949	1950
	1951	1952	1953	1954	1955
PAGE 7	1956	1957	1958	1959	1960

Figure 36. SYSLST Output for Tape-to-Printer Sample Problems
(Part 3 of 4)

1961	1962	1963	1964	1965
1966	1967	1968	1969	1970
1971	1972	1973	1974	1975
1976	1977	1978	1979	1980
1981	1982	1983	1984	1985
1986	1987	1988	1989	1990
1991	1992	1993	1994	1995
1996	1997	1998	1999	2000

BGOOD IS IT EOF
 REPLY Y
 END OF DATA

 PAGE 8

NUMBER OF INPUT BLOCKS PROCESSED 000400
 NUMBER OF OUTPUT BLOCKS PROCESSED 000400
 END OF JOB

EOJ TPRR

Figure 36. SYSLST Output for Tape-to-Printer Sample Problem
(Part 4 of 4)

Assembler 5

Program Name is Z.AS5. The Assembler 5 sample problem generates numbers from 2000 to 0001 in descending order and writes them to a 2311 disk storage device. To execute the Assembler 5 sample problem, the following job control cards are needed:

```

// JOB ASSEMBLY SAMPLE 5
// OPTION LINK, LIST, LOG, NOXREF
// EXEC ASSEMBLY
//          Assembler source deck (23 cards)
/*
// EXEC LNKEDT
// PAUSE ASSGN SYS002 TO SCRATCH PACK
// ASSGN SYS002, X'cuu'
// VOL SYS002, OUTFILE
// DLAB 'SAMPLE PROBLEM FILE OF 2000 RECORDS      1hhhhh',      X
//          Col. 16
//          0001,66060,66080, ' SAMPLE TEST '
// XTENT 1,000,000180000,000184002,' hhhhhh',SYS002
// EXEC
//&
```

Col. 54 Col. 72
↓ ↓

Note: Replace hhhhhh in the DLAB and XTENT cards with the volume serial number of the disk pack.

SYSLOG output is shown in Figure 17.

Following is a summary of the SYSLST output shown in Figure 37:

- Job control cards
- External symbol dictionary
- Source program listing
- Relocation dictionary
- Linkage editor storage map

```
// JOB ASSEMBLY SAMPLE 5
// OPTION LINK,LIST,LOG,NOXREF
// EXEC ASSEMBLY
```

EXTERNAL SYMBOL DICTIONARY

PAGE 1

SYMBOL	TYPE	ID	ADDR	LENGTH	LD	ID
	PC	01	00000C	0C017C		
IJGF0ZZZ	ER	02				
IJGF0ZZZ	SD	03	000180	000202		

DOS ASSEMBLER TEST

PAGE 1

LOC	OBJECT CODE	ADDR1	ADDR2	STMT	SOURCE STATEMENT	DOS CL3-1 08/10/68
				2	PRINT NOGEN	\$4650502
				3	START 0	\$4650503
000000				4	TESTGEN BALR 8,0	\$4650504
000000	0580			5	USING *,8	\$4650505
000002				6	LA 13,SAVEAREA	\$4650506
000002	41D0 811E		00120	7	OPEN OUTFILE	\$4650507
000016	4130 07D0		007D0	15	LA 3,2000	\$4650508
00001A	4E30 8116		00118	16	NEXT CVD 3,0WD	\$4650509
00001E	F337 2C08	8116	00008	17	UNPK 11(4,2),0WD	\$4650510
000024	96F0 200E		0000E	18	OI 14(2),X*FO*	\$4650511
				19	PUT OUTFILE	\$4650512
000034	4630 8018		0001A	24	BCT 3,NEXT	\$4650513
				25	CLOSE OUTFILE	\$4650514
				33	EOJ	\$4650515
				36	OUTFILE DTFSD BLKSIZE=23, IOAREA1=A1, IOAREA2=A2, TYPEFL=OUTPUT, IOREG=(2), RECFORM=FIXUNB, DEVICE=2311	\$4650516
				86	SOMODFO	\$4650517
0000E8	4040404040404040			263	A1 DC 23C' *	\$4650518
0000FF	4040404040404040			264	A2 DC 23C' *	\$4650519
000118				265	0WD DS 0	\$4650520
000120				266	SAVEAREA US 9D	\$4650521
00000C				267	END TESTGEN	\$4650522
000168	5858C2D6D7C5D540			268	=C'\$\$8OPEN'	\$4650523
000170	5858C2C3J3D6E2C5			269	=C'\$\$8CLOSE'	
000178	00000048			270	=A(OUTFILE)	

RELOCATION DICTIONARY

PAGE 1

POS.ID	REL.ID	FLAGS	ADDRESS
01	01	0C	000010
01	01	0C	000040
01	01	0C	000050
01	02	18	000059
01	01	08	000071
01	01	0C	000074
01	01	0C	0000A0
01	01	0C	0000A8
01	01	08	000081
01	01	08	000089
01	01	08	0000C1
01	01	08	0000C9
01	01	08	0000D1
01	01	08	0000D9
01	01	08	0000E1
01	01	0C	000178

NO STATEMENTS FLAGGED IN THIS ASSEMBLY

Figure 37. SYSIST Output for Assembler (AS5) Sample Problems (Part 1 of 2)

```

// EXEC LNKEDT

JOB ASSEMBLY 08/10/68 DISK LINKAGE EDITOR DIAGNOSTIC OF INPUT
ACTION TAKEN MAP
LIST ENTRY

08/10/68 PHASE XFR-AD LOCORE HICORE DSK-AD ESD TYPE LABEL LOADED REL-FR
          PHASE*** 002800 002800 002881 2B 06 2 CSECT          002800 002800
                                     CSECT IJGF0ZZZ 002980 002800

// PAUSE ASSGN SYS002 TO SCRATCH PACK
// ASSGN SYS002,X*191*
// VOL SYS002,OUTFILE
// DLAB 'SAMPLE PROBLEM FILE GF 2000 RECORDS          1191191*', X
//          0001.66066.66080,' SAMPLE TEST '
// XTENT 1,000,000180000,000184002,'191191',SYS002
// EXEC

EDJ ASSEMBLY

```

Figure 37. SYSLST Output for Assembler (AS5) Sample Problems (Part 2 of 2)

Tape and Disk Sort/Merge -- 2311 Application

Program Name is Z.SM5. The tape and disk sort/merge sample problem rearranges in ascending sequence the records produced by the Assembler 5 program and writes them back to a 2311 disk storage device. To execute the tape and disk sort/merge sample problem the following job control cards are needed:

```

// JOB SORT 2311
// PAUSE ASSGN SYS001,SYS002,SYS003 TO SCRATCH PACK
// ASSGN SYS001,X'cuu'
// ASSGN SYS002,X'cuu'
// ASSGN SYS003,X'cuu'
// VOL SYS001, SORTCUT
// DLAB 'SORTED FILE OF 2000 RECORDS FOR UTILITIES 1hhhhh', X
//          Col. 16
//          0001,66080,66080 'SAMPLE TEST '
// XTENT 1,000,000171000,000174002,'hhhhh',SYS001
// VOL SYS002, SORTIN1
// DLAB 'SAMPLE PROBLEM FILE OF 2000 RECORDS 1hhhhh', X
//          Col. 16
//          0001,66080,66080,'SAMPLE TEST '
// XTENT 1,000,000180000,000184002,'hhhhh',SYS002
// VOL SYS003, SORTWK1
// DLAB 'SAMPLE PROGRAM WORK AREA FOR SORT RUN 1hhhhh', X
//          Col. 16
//          0001,66080,66080,'SAMPLE TEST '
// XTENT 1,000,000184003,000187005,'hhhhh',SYS003
// EXEC SORT
// Sort/merge control cards (6 cards)
/ε
```

Note: Replace hhhhhh in the DLAB and XTENT cards with the volume serial number of the disk pack.

SYSIOG output is shown in Figure 17.

The following list summarizes the SYSLST output shown in Figure 38:

- Job control cards
- Sort control cards
- Sort parameters
- Computed constants

```

// JOB SORT 2311
// PAUSE ASSIGN SYS001, SYS002, SYS003 TO SCRATCH PACK
// ASSIGN SYS001, X*191*
// ASSIGN SYS002, X*191*
// ASSIGN SYS003, X*191*
// VCL SYS001, SORTOUT
// DLAB 'SORTED FILE OF 2000 RECORDS FOR UTILITIES      1191191',      X
//          GG01.66080,66080,' SAMPLE TEST '
// XTENT 1,000,000171000,GG0174002,'191191',SYS001
// VOL SYS002,SORTIN1
// DLAB 'SAMPLE PROBLEM FILE OF 2000 RECORDS          1191191',      X
//          GG01.66080,66080,' SAMPLE TEST '
// XTENT 1,000,000180000,GG0184002,'191191',SYS002
// VOL SYS003,SORTMK1
// DLAB 'SAMPLE PROGRAM WORK AREA FOR SORT RUN      1191191',      X
//          GG01.66080,66080,' SAMPLE TEST '
// XTENT 1,000,000184000,GG0187005,'191191',SYS003
// EXEC SORT

70001 SORT FIELDS=(11,4,A),FORMAT=BI,SIZE=2000,WORK=1          $4830101
70001 RECORD TYPE=F,LENGTH=(15,,15)                          $4830102
70001 INPFI BLKSIZE=75                                       $4830103
70001 OUTFI BLKSIZE=75                                       $4830104
70001 OPTION PRINT=ALL,LABEL=(S,S),STORAGE=10240             $4830105
70001 END                                                       $4830106
70501 NMAX = 00003432
70511 B = 00000828
70521 G = 00000112
70011 PHASE G END,NO DETECTED ERRORS

```

```

EOJ SORT

```

Figure 38. SYSLST Output for Tape and Disk Sort/Merge Sample Problem

Disk-to-Printer Utility

Program Name is Z.UTDKPR2. The disk-to-printer utility sample problem lists the numbers handled by the Assembler 5 and tape and disk sort/merge (2311 application) sample problems. To execute the disk-to-printer utility sample problem, the following job control cards are needed:

```

// JOB DKPR 2311 TO PRINTER
// PAUSE ASSGN SYS004 TO SCRATCH PACK
// ASSGN SYS004,X'cuu'
// PAUSE ASSGN SYS005 TO THE PRINTER
// ASSGN SYS005,X'cuu'
// UPSI 000
// VOL SYS004, UIN
// DLAB 'SORTED FILE OF 2000 RECORDS FOR UTILITIES 1hhhhh', X
// XTENT 1,000,000171000,000174002,'hhhhh',SYS004
// EXEC DKPR
// Disk-to-printer utility control cards (2 cards)
/*
```

Col. 54 Col. 72
↓ ↓

Note: Replace hhhhh in the DLAB and XTENT cards with the volume serial number of the disk pack.

SYSLOG output is shown in Figure 17.

The following list summarizes the SYSLST output shown in Figure 39:

- Job control cards
- Utility parameter statements (10 lines)
- Numbers 0001-2000 (400 lines)
- NUMBER OF INPUT BLOCKS PROCESSED 000400
- NUMBER OF OUTPUT BLOCKS PROCESSED 000400
- END OF JOB

```

// JOB DKPR 2311 TO PRINTER
// PAUSE ASSIGN SYS004 TO SCRATCH PACK
// ASSIGN SYS004,X*191*
// PAUSE ASSIGN SYS005 TO THE PRINTER
// ASSIGN SYS005,X*0GE*
// UPSI 000
// VOL SYS004, UIN
// DLAB *SORTED FILE OF 2000 RECORDS FOR UTILITIES 1191191*, X
// ATENT 1,000,000171000,000174002,*191191*,SYS004
// EXEC DKPR

```

```

// UCP TL,FF,A=(75,75),B=(120),UC,S1,PY $*19101
// END $*19102
DISK TO PRINT UTILITY
INPUT RECORD LENGTH 0075
OUTPUT RECORD LENGTH 0120
INPUT BLOCK LENGTH 00075
OUTPUT BLOCK LENGTH 00120
OUTPUT OPTION PRINT CHARACTER
2 INPUT,2 OUTPUT AREAS ASSIGNED
RECORD FORMAT FIXED
TYPE LIST
STARTING RECORD NUMBER 0000001
INPUT DEVICE TYPE 2311

```

```

0001      0002      0003      0004      0005
0006      0007      0008      0009      0010
0011      0012      0013      0014      0015
0016      0017      0018      0019      0020
0261      0262      0263      0264      0265
0266      0267      0268      0269      0270

```

PAGE 1

```

0271      0272      0273      0274      0275
0276      0277      0278      0279      0280
0281      0282      0283      0284      0285
0286      0287      0288      0289      0290
0530      0531      0532      0533      0534
0535      0536      0537      0538      0539
0540      0541      0542      0543      0544
0545      0546      0547      0548      0549

```

PAGE 2

Figure 39. SYSIST Output for Disk-to-Printer Sample Problems (UTDKPR2) (Part 1 of 3)

0551	0552	0553	0554	0555
0556	0557	0558	0559	0568
0567	0566	0565	0564	0563
0562	0561	0560	0569	0570
0571	0572	0573	0574	0575
0576	0577	0578	0579	0580
0802	0801	0800	0807	0806
0811	0812	0813	0814	0815
0816	0817	0818	0819	0820
0821	0822	0823	0824	0825
0826	0827	0828	0829	0830
PAGE 3				
0831	0832	0833	0834	0835
0836	0837	0838	0839	0840
0841	0842	0843	0844	0845
0846	0847	0848	0849	0850
0851	0852	0853	0854	0855
0856	0857	0858	0859	0860
1096	1097	1098	1099	1100
1101	1102	1103	1104	1105
1106	1107	1108	1109	1110
PAGE 4				
1111	1112	1113	1114	1115
1116	1117	1118	1119	1120
1121	1122	1123	1124	1125
1126	1127	1128	1129	1130
1366	1367	1368	1369	1370
1371	1372	1373	1374	1375
1376	1377	1378	1379	1380
1381	1382	1383	1384	1385
1386	1387	1388	1389	1390
PAGE 5				

Figure 39. SYSLST Output for Disk-to-Printer Sample Problems (UTDKPR2)
(Part 2 of 3)

Assembler 6

Program Name is Z.AS6. The Assembler 6 sample problem generates numbers from 3000 to 0001 in descending order and writes them to a 2314 direct access storage facility. To execute the Assembler 6 sample problem, the following job control cards are needed:

```

// JOB ASSEMBLY SAMPLE 6
// OPTION LINK,LIST,LOG,NOXREF
// EXEC ASSEMBLY
// Assembler source deck (23 cards)
/*
// EXEC INKEDT
// PAUSE ASSGN SYS002 TO SCRATCH PACK
// ASSGN SYS002,X'cuu'
// VOL SYS002,OUTFILE
// DLAB 'SAMPLE PROBLEM FILE OF 2000 RECORDS      1hhhhh',      X
//                               Col. 16
//                               0001,66060,66080,' SAMPLE TEST '
// XTENT 1,000,000180000,000184002,' hhhhhh',SYS002
// EXEC
/ε
```

Note: Replace hhhhhh in the DLAB and XTENT cards with the volume serial number of the disk pack.

SYSLOG output is shown in Figure 17.

The following list summarizes the SYSLST output shown in Figure 40:

- Job control cards
- External symbol dictionary
- Source program listing
- Relocation dictionary
- Linkage editor storage map

```
// JOB ASSEMBLY SAMPLE 6
// OPTION LINK,LIST,LOG,NOXREF
// EXEC ASSEMBLY
```

```
SYMBOL TYPE ID ADDR LENGTH LO IO
```

EXTERNAL SYMBOL DICTIONARY

PAGE 1

```
IJGFUZZ PC 01 00000 00017C
IJGFUZZ ER 02
IJGFZZZ SD 03 00018C 000202
```

DOS ASSEMBLER TEST

PAGE 1

LOC	OBJECT CODE	ADDR1	ADDR2	STMT	SOURCE STATEMENT	DOS CL3-1 08/10/68
				2	PRINT NOGEN	\$4650602
000000				3	START 0	\$4650603
000000	0580			4	TESTGEN BALR 8,0	\$4650604
000002				5	USING +,8	\$4650605
000002	4100 811E		0012C	6	LA 13,SAVEAREA	\$4650606
				7	OPEN OUTFILE	\$4650607
000016	4130 0888		G0888	15	LA 3,3000	\$4650608
00001A	4E30 8116		GG118	16	NEXT CVD 3,DWD	\$4650609
00001E	F337 2GG8 8116	C0008	00118	17	UNPK 11(4,2),DWD	\$4650610
000024	96F0 200E		0000E	18	OI 14(2),X'FG'	\$4650611
				19	PUT OUTFILE	\$4650612
000034	4630 8018		00G1A	24	BCT 3,NEXT	\$4650613
				25	CLOSE OUTFILE	\$4650614
				33	EDJ	\$4650615
				36	OUTFILE OTFSO	\$4650616
				86	SDMO0FO	\$4650617
0000E8	4040404040404040			263	A1 DC 23C' *	\$4650618
0000FF	4040404040404040			264	A2 DC 23C' *	\$4650619
000118				265	DWD OS 0	\$4650620
000120				266	SAVEAREA OS 0	\$4650621
000000				267	END TESTGEN	\$4650622
000168	5858C2D6D7C5D540			268	=C' \$BOPEN *	\$4650623
000170	5858C2C3D3D6E2C5			269	=C' \$BCLOSE *	
000178	00000048			270	=A(OUTFILE)	

RELOCATION DICTIONARY

PAGE 1

POS.10	REL.ID	FLAGS	ADDRESS
01	01	0C	000010
01	01	0C	000040
01	01	0C	000050
01	02	18	000059
01	01	08	000071
01	01	0C	000074
01	01	0C	0000A0
01	01	0C	0000A8
01	01	08	0000B1
01	01	08	0000B9
01	01	08	0000C1
01	01	08	0000C9
01	01	08	0000D1
01	01	08	0000D9
01	01	08	0000E1
01	01	0C	000178

NO STATEMENTS FLAGGED IN THIS ASSEMBLY

Figure 40. SYSLST Output for Assembler (AS6) Sample Problems (Part 1 of 2)

```

// EXEC LNKEDT

JOB ASSEMBLY 08/10/68 DISK LINKAGE EDITOR DIAGNOSTIC OF INPUT
ACTION TAKEN MAP
LIST ENTRY

08/10/68 PHASE XFR-AD LGCORE HICORE DSK-AD ESD TYPE LABEL LOADED REL-FR
PHASE*** 002800 002800 002801 2B 06 2 CSECT 002800 002800
CSECT IJGFQZZZ 002980 002800

// PAUSE ASSGN SYS002 TO SCRATCH PACK
// ASSGN SYS002,X*230*
// VOL SYS002,OUTFILE
// DLAB *SAMPLE PROBLEM FILE OF 3000 RECORDS 1X30X30*, X
// XTENT 1,000,000180000,000184002,*X30X30*,SYS002
// EXEC

EOJ ASSEMBLY

```

Figure 40. SYSLST Output for Assembler (AS6) Sample Problems (Part 2 of 2)

Tape and Disk Sort/Merge -- 2314 Application

Program Name is Z.SM6. The tape and disk sort/merge sample problem rearranges the records produced by the Assembler 6 program in ascending sequence and writes them back to a 2314 direct access storage facility. To execute the tape and disk sort/merge sample problem the following job control cards are needed:

```

                                                                    Col. 54      Col. 72
                                                                    ↓           ↓
// JOB SORT 2314
// PAUSE ASSGN SYS001,SYS002,SYS003 TO SCRATCH PACK
// ASSGN SYS001,S'cuu'
// ASSGN SYS002,X'cuu'
// ASSGN SYS003,X'cuu'
// VOL SYS001, SORTOUT
// DLAB 'SORTED FILE OF 2000 RECORDS FOR UTILITIES 1hhhhhh', X
           Col. 16
           0001,66080,66080,' SAMPLE TEST '
// XTENT 1,000,000171000,000174002,'hhhhhh',SYS001
// VOL SYS002, SORTIN1
// DLAB 'SAMPLE PROBLEM FILE OF 2000 RECORDS      1hhhhhh', X
           Col. 16
           0001,66080,66080,' SAMPLE TEST '
// XTENT 1,000,000180000,000184002,'hhhhhh',SYS002
// VOL SYS003, SORTWK1
// DLAB 'SAMPLE PROGRAM WORK AREA FOR SORT RUN    1hhhhhh', X
           Col. 16
           0001,66080,66080,' SAMPLE TEST ,
// XTENT 1,000,000184003,000187005,'hhhhhh',SYS003
// EXEC SORT
           Sort/merge control cards (6 cards)
/£
```

Note: Replace hhhhhh in the DLAB and XTENT cards with the volume serial number of the disk pack.

SYSLLOG output is shown in Figure 17.

The following list summarizes the SYSLST output shown in Figure 41:

- Job control cards
- Sort control cards
- Sort parameters
- Computed constants

```

// JOB SORT 2314
// PAUSE ASSGN SYS001,SYS002,SYS003 TO SCRATCH PACK
// ASSGN SYS001,X'230'
// ASSGN SYS002,X'230'
// ASSGN SYS003,X'231'
// VOL SYS001,SORTOUT
// DLAB 'SORTED FILE OF 3000 RECORDS FOR UTILITIES 1X30X30', X
//          0001,66080,66080,' SAMPLE TEST '
// XTENT 1,000,000171000,000174002,'X30X30',SYS001
// VOL SYS002,SORTINI
// DLAB 'SAMPLE PROBLEM FILE OF 3000 RECORDS 1X30X30', X
//          0001,66080,66080,' SAMPLE TEST '
// XTENT 1,000,000180000,000184002,'X30X30',SYS002
// VOL SYS003,SORTWK1
// DLAB 'SAMPLE PROGRAM WORK AREA FOR SORT RUN 1X31X31', X
//          0001,66080,66080,' SAMPLE TEST '
// XTENT 1,000,000184003,000187005,'X31X31',SYS003
// EXEC SORT

7000I SORT FIELDS=(11,4,A),FORMAT=BI,SIZE=3000,WORK=1 $4830201
7000I RECORD TYPE=F,LENGTH=(15,,15) $4830202
7000I INPFIL BLKSIZE=75 $4830203
7000I DUTFIL BLKSIZE=75 $4830204
7000I OPTION PRINT=ALL,LABEL=(S,S),STORAGE=22528 $4830205
7000I END $4830206
7050I NMAX = 00013540
7051I B = 00001683
7052I G = 0000443
7001I PHASE 0 END,NO DETECTED ERRORS

```

```

EQJ SORT

```

Figure 41. SYSLST Output for Tape and Disk Sort/Merge Sample Problem (SM6)

Disk-to-Printer Utility

Program Name is Z.UTDKPR3. The disk-to-printer utility sample problem lists the numbers handled by the Assembler 6 and tape and disk sort/merge (2314 application) sample problems. To execute the disk-to-printer utility sample problem, the following job control cards are needed:

```

// JOB DKPR 2314 TO PRINTER
// PAUSE ASSGN SYS004 TO SCRATCH PACK
// ASSGN SYS004,X'cuu'
// PAUSE ASSGN SYS005 TO THE PRINTER
// ASSGN SYS005,X'cuu'
// UPSI 000
// VOL SYS004, UIN
// DLAB 'SORTED FILE OF 2000 RECORDS FOR UTILITIES 1hhhhh', X
//          Col. 16
//          0001,66080,66080,' SAMPLE TEST '
// XTENT 1,000,000171000,000174002,'hhhhh',SYS004
// EXEC DKPR
//          Disk-to-printer utility control cards (2 cards)
/*

```

Col. 54 Col. 72
↓ ↓

Note: Replace hhhhhh in the DLAB and XTENT cards with the volume serial number of the disk pack.

SYSLLOG output is shown in Figure 17.

The following list summarizes the SYSLST output shown in Figure 42:

- Job control cards
- Disk-to-printer control cards
- Utility parameter statements (10 lines)
- Numbers 0001-3000 (600 lines)
- NUMBER OF INPUT BLOCKS PROCESSED 000600
- NUMBER OF OUTPUT BLOCKS PROCESSED 000600
- END OF JOB

```

// JOB DKPR 2314 TO PRINTER
// PAUSE ASSIGN SYSG04 TO SCRATCH PACK
// ASSIGN SYSG04,X'230'
// PAUSE ASSIGN SYSG05 TO THE PRINTER
// ASSIGN SYSG05,X'00E'
// UPST 000
// VOL SYSG04, UJM
// DLAB *SORTED FILE OF 3000 RECORDS FOR UTILITIES 1X30X30*, X
//          G001,6608C,06080,' SAMPLE TEST '
// XTENT 1,G00,00017100G,000174002,*X30X30',SYSG04
// EXEC DKPR

```

```

// UDP TL,FF,A=(175,75),B=(120),OC,S1,PY,E=(2314)          $4610201
// END                                                       $4610202
DISK TO PRINT UTILITY
INPUT RECORD LENGTH 0075
OUTPUT RECORD LENGTH 0120
INPUT BLOCK LENGTH 00075
OUTPUT BLOCK LENGTH 00120
OUTPUT OPTION PRINT CHARACTER
2 INPUT,2 OUTPUT AREAS ASSIGNED
RECORD FORMAT FIXED
TYPE LIST
STARTING RECORD NUMBER C00G0001
INPUT DEVICE TYPE 2314

```

0001	0002	0003	0004	0005
0006	0007	0008	0009	0010
0011	0012	0013	0014	0015
0016	0017	0018	0019	0020
0251	0252	0253	0254	0255
0256	0257	0258	0259	0260
0261	0262	0263	0264	0265
0266	0267	0268	0269	0270

PAGE 1

Figure 42. SYSLST Output for Disk-to-Printer Sample Problems (UTDKPR3)
(Part 1 of 5)

	0271	0272	0273	0274	0275
	0276	0277	0278	0279	0280
	0281	0282	0283	0284	0285
	0286	0287	0288	0289	0290
	0291	0292	0293	0294	0295
	0296	0297	0298	0299	0300
	0301	0302	0303	0304	0305
	0306	0307	0308	0309	0310
	0311	0312	0313	0314	0315
	0316	0317	0318	0319	0320
	0321	0322	0323	0324	0325
	0326	0327	0328	0329	0330
PAGE 2	0331	0332	0333	0334	0335
	0336	0337	0338	0339	0340
	0341	0342	0343	0344	0345
	0346	0347	0348	0349	0350
	0351	0352	0353	0354	0355
	0356	0357	0358	0359	0360
	0361	0362	0363	0364	0365
	0366	0367	0368	0369	0370
	0371	0372	0373	0374	0375
	0376	0377	0378	0379	0380
	0381	0382	0383	0384	0385
	0386	0387	0388	0389	0390
	0391	0392	0393	0394	0395
	0396	0397	0398	0399	0400
	0401	0402	0403	0404	0405
	0406	0407	0408	0409	0410
	0411	0412	0413	0414	0415
	0416	0417	0418	0419	0420
	0421	0422	0423	0424	0425
	0426	0427	0428	0429	0430
PAGE 3	0431	0432	0433	0434	0435
	0436	0437	0438	0439	0440
	0441	0442	0443	0444	0445
	0446	0447	0448	0449	0450
	0451	0452	0453	0454	0455
	0456	0457	0458	0459	0460
	0461	0462	0463	0464	0465
	0466	0467	0468	0469	0470
	0471	0472	0473	0474	0475
	0476	0477	0478	0479	0480
	0481	0482	0483	0484	0485
	0486	0487	0488	0489	0490
	0491	0492	0493	0494	0495
	0496	0497	0498	0499	0500
	0501	0502	0503	0504	0505
	0506	0507	0508	0509	0510
	0511	0512	0513	0514	0515
	0516	0517	0518	0519	0520
	0521	0522	0523	0524	0525
	0526	0527	0528	0529	0530
PAGE 4	0531	0532	0533	0534	0535
	0536	0537	0538	0539	0540
	0541	0542	0543	0544	0545
	0546	0547	0548	0549	0550
	0551	0552	0553	0554	0555
	0556	0557	0558	0559	0560
	0561	0562	0563	0564	0565
	0566	0567	0568	0569	0570
	0571	0572	0573	0574	0575
	0576	0577	0578	0579	0580
	0581	0582	0583	0584	0585
	0586	0587	0588	0589	0590
	0591	0592	0593	0594	0595
	0596	0597	0598	0599	0600
	0601	0602	0603	0604	0605
	0606	0607	0608	0609	0610
	0611	0612	0613	0614	0615
	0616	0617	0618	0619	0620
	0621	0622	0623	0624	0625
	0626	0627	0628	0629	0630
	0631	0632	0633	0634	0635
	0636	0637	0638	0639	0640
	0641	0642	0643	0644	0645
	0646	0647	0648	0649	0650
	0651	0652	0653	0654	0655
	0656	0657	0658	0659	0660
	0661	0662	0663	0664	0665
	0666	0667	0668	0669	0670
	0671	0672	0673	0674	0675
	0676	0677	0678	0679	0680
	0681	0682	0683	0684	0685
	0686	0687	0688	0689	0690
	0691	0692	0693	0694	0695
	0696	0697	0698	0699	0700
	0701	0702	0703	0704	0705
	0706	0707	0708	0709	0710

Figure 42. SYSLST Output for Disk-to-Printer Sample Problems (UTDKPR3)
(Part 2 of 5)

	1111	1112	1113	1114	1115
	1116	1117	1118	1119	1120
	1121	1122	1123	1124	1125
	1126	1127	1128	1129	1130
	1366	1367	1368	1369	1370
	1371	1372	1373	1374	1375
	1376	1377	1378	1379	1380
	1381	1382	1383	1384	1385
PAGE 5	1386	1387	1388	1389	1390
	1391	1392	1393	1394	1395
	1396	1397	1398	1399	1400
	1401	1402	1403	1404	1405
	1406	1407	1408	1409	1410
	1411	1412	1413	1414	1415
	1646	1647	1648	1649	1650
	1651	1652	1653	1654	1655
	1656	1657	1658	1659	1660
	1661	1662	1663	1664	1665
PAGE 6	1666	1667	1668	1669	1670
	1671	1672	1673	1674	1675
	1676	1677	1678	1679	1680
	1681	1682	1683	1684	1685
	1686	1687	1688	1689	1690
	1926	1927	1928	1929	1930
	1931	1932	1933	1934	1935
	1936	1937	1938	1939	1940
	1941	1942	1943	1944	1945
PAGE 7	1946	1947	1948	1949	1950

Figure 42. SYSLST Output for Disk-to-Printer Sample Problems (UTDKPR3)
(Part 3 of 5)

	1951	1952	1953	1954	1955
	1956	1957	1958	1959	1960
	1961	1962	1963	1964	1965
	1966	1967	1968	1969	1970
	2211	2212	2213	2214	2215
	2216	2217	2218	2219	2220
	2221	2222	2223	2224	2225
	2226	2227	2228	2229	2230
PAGE 8					
	2231	2232	2233	2234	2235
	2236	2237	2238	2239	2240
	2241	2242	2243	2244	2245
	2246	2247	2248	2249	2250
	2251	2252	2253	2254	2255
	2486	2487	2488	2489	2490
	2491	2492	2493	2494	2495
	2496	2497	2498	2499	2500
	2501	2502	2503	2504	2505
	2506	2507	2508	2509	2510
PAGE 9					
	2511	2512	2513	2514	2515
	2516	2517	2518	2519	2520
	2521	2522	2523	2524	2525
	2526	2527	2528	2529	2530
	2766	2767	2768	2769	2770
	2771	2772	2773	2774	2775
	2776	2777	2778	2779	2780
	2781	2782	2783	2784	2785
	2786	2787	2788	2789	2790
PAGE 10					

Figure 42. SYSLSL Output for Disk-to-Printer Sample Problem (UTDKPR3)
(Part 4 of 5)

2791	2792	2793	2794	2795
2796	2797	2798	2799	2800
2801	2802	2803	2804	2805
2806	2807	2808	2809	2810
2811	2812	2813	2814	2815
2816	2817	2818	2819	2820
2821	2822	2823	2824	2825
2826	2827	2828	2829	2830
2831	2832	2833	2834	2835
2836	2837	2838	2839	2840
2841	2842	2843	2844	2845
2846	2847	2848	2849	2850
2851	2852	2853	2854	2855
2856	2857	2858	2859	2860
2861	2862	2863	2864	2865
2866	2867	2868	2869	2870
2871	2872	2873	2874	2875
2876	2877	2878	2879	2880
2881	2882	2883	2884	2885
2886	2887	2888	2889	2890
2891	2892	2893	2894	2895
2896	2897	2898	2899	2900
2901	2902	2903	2904	2905
2906	2907	2908	2909	2910
2911	2912	2913	2914	2915
2916	2917	2918	2919	2920
2921	2922	2923	2924	2925
2926	2927	2928	2929	2930
2931	2932	2933	2934	2935
2936	2937	2938	2939	2940
2941	2942	2943	2944	2945
2946	2947	2948	2949	2950
2951	2952	2953	2954	2955
2956	2957	2958	2959	2960
2961	2962	2963	2964	2965
2966	2967	2968	2969	2970
2971	2972	2973	2974	2975
2976	2977	2978	2979	2980
2981	2982	2983	2984	2985
2986	2987	2988	2989	2990
2991	2992	2993	2994	2995
2996	2997	2998	2999	3000

END OF DATA
PAGE 11

NUMBER OF INPUT BLOCKS PROCESSED 000600
NUMBER OF OUTPUT BLOCKS PROCESSED 000600
END OF JOB

EUJ DKPR

Figure 42. SYSLST Output for Disk-to-Printer Sample Problem (UTDKPR3)
(Part 5 of 5)

Autotest

Program Name is Z.AT1. The Autotest sample problem demonstrates to the problem programmer some of the more useful features of Autotest. Basically, the program is a two-step loop that:

1. Reads a data card, and
2. Moves certain fields of the card to designated storage areas.

This simple loop is repeated five times before the end-of-job routine is entered. The Autotest sample problem source program listing is shown in Figure 43.

If the Autotest sample problem is run in a multiprogramming system, no core may be allocated to the foreground area (F1 and F2=0K).

All Autotest control cards have a ./ punched in columns 1 and 2, respectively. The first and second Autotest control cards perform any phase and control section qualification included in the test deck. Because the example has only a single phase and one control section, no modification is required and these two cards could be eliminated.

Autopatch capabilities are demonstrated by the next six control cards, resulting in the following action:

- A new instruction is added to the program between two other existing instructions.
- One instruction is exchanged for another.
- The assembled value of a constant is changed.

Another important function of Autotest is demonstrated by the test request cards (./ TR). The first of these cards initiates test request Number 001, and the following continuation card initiates test request Number 002. These two cards result in the following:

- The 16 general registers and the two areas of storage at SYMA and SYMC+3 are displayed prior to executing the instruction at THERE. (Because there are five data cards, this request will be executed five times.)
- The storage locations IN+75 and IN+76 are displayed for only the second and fourth data cards as specified by the ON parameters.

The ./ PCC card (program control card) gives a normal end-of-job storage printout. This printout can have one or more formats.

The user installation must define the work area for Autotest if nonstandard labels are used. In the case of nonstandard labels, the job control cards required are: DLBL and EXTENT. The file name in the VOL card must be IJSYSAT. Twenty tracks are required in the EXTENT card. Only one work area may be assigned and it must be continuous unless the split-cylinder concept is used. If this concept is used, refer to IBM System/360 Disk Operating System, System Control and System Service Programs, Form C24-5036. For additional information concerning Autotest work files, refer to IBM System/360 Disk Operating System, Autotest, Form C24-5062.

The job control cards used in executing the Autotest sample problem are:

```
// JOB AUTOTEST
// OPTION SYM,LINK
// EXEC ASSEMBLY
AUTOTEST SOURCE DECK (27 cards)
/*
// EXEC ATLEDT
./ PHQ AAAAAAAAA
./ CSQ CSECT1
./ ADD THERE -6,40
      MVC      SYMB,SYMA  *D203A08EA086
./ EXC BC2,2
* 4710A034
./ CON SYMA,2
* 0000000000000000
./ TR THERE,,CPL,SYMA,SYMC+3,,C,G
      Col. 16
      DSP,IN+75,IN+76,(2,4,2),B
./ PCC AMS,AMS,2000
// EXEC
AUTOTEST DATA DECK (5 cards)
/*
./ ATEOF
```

SYSLOG output is shown in Figure 17.

The following list summarizes the SYSLST output shown in Figure 43:

- Job control cards
- External symbol dictionary
- Source program listing
- Relocation dictionary
- Cross-reference
- Linkage editor input diagnostic
- ./ Autotest control cards (11 cards)
- Autotest data (5 cards)
- Test requests
- Normal EOF storage dump
- EOJ AUTOTEST

Autotest Problem Test Results

For the following discussion, refer to the circled letters on the SYSLST output for the Autotest sample problem, Figure 43. The Autopatch control card (./ ADD THERE-6,40) inserts an additional instruction between statement numbers 10 and 11 (see A). The core dump at the end of the program shows that the instruction at MVC2 (see E) has been replaced by a supervisor call (SVC 254). This instruction forms a link to the patch area in storage. The actual patch is displayed at (F) and consists of two MVC instructions and SVC 255 which forms the return link

to the instruction located at THERE. The instruction (./ EXC BC2,2) causes the instruction at BC2 (see B) to be replaced by SVC 253. The core dump shows the resulting patch at points G and H. Finally, the constant at C is changed from one to zero before program execution. The test requests at location THERE (see D) are shown on a separate page of the listing (Figure 43). Test request Number 1 is displayed a total of five times, once for each data card. Test request Number 2 appears only for the second and fourth data cards. The rest of the printout contains the normal EOJ core dump.

```

// JOB AUTOTEST
// OPTION SYM,LINK
// EXEC ASSEMBLY

```

EXTERNAL SYMBOL DICTIONARY

```

SYMBOL TYPE ID ADDR LENGTH LD ID
CSECT1  S0 01 000000 000084

```

LOC	OBJECT CODE	ADDR1	ADDR2	STMT	SOURCE STATEMENT	DOS CL3-0	
				1	REPRD	\$4590001	
				2	PHASE AAAAAAA,S	\$4590002	
C0000C				3	CSECT1	\$4590003	
000002				4	R2 EQU 2	\$4590004	
000003				5	R3 EQU 3	\$4590005	
C0000A				6	R10 EQU 10	\$4590006	
C00000	05A0			7	HERE BALK R10,0	\$4590007	
C00002				8	USING *,R10	\$4590008	
000002	4520	A018	0001A	9	BAL1 BAL R2,READ	\$4590009	
C00006	E203	A086	A040	00088	00042	10 MVC1 MVC SYMA(4),IN+10	\$4590010
C0000C	D203	A092	A081	00094	00083	11 MVC2 MVC SYMC(4),IN+75	\$4590011
000012	4830	AC92		00094	12 THERE LH R3,SYMC	\$4590012	
000016	47F0	A000		00002	13 BC1 BC 15,HERE+2	\$4590013	
00001A				14	READ EQU *	\$4590014	
				15	CHAN EXCP CARDCCB	\$4590015	
				16	** 360N-CL-453 EXCP CHANGE LEVEL 3-0		
00001A	5810	A0AE	000B0	17	CHAN L 1,=(CARDCCB)		
00G01E	CAGG			18	SVC 0		
				19	WAIT1 WAIT CARDCCB	\$4590016	
				20	** 360N-CL-453 WAIT CHANGE LEVEL 3-0		
000020	5810	A0AE	000B0	21	WAIT1 L 1,=(CARDCCB)		
G00024	9180	1002	00002	22	TM 2(1),X*80*		
0L0028	471C	A02C	0G02E	23	B0 **0		
00002C	CA07			24	SVC 7		
00002E	9101	A09A	0009C	25	TEST2 TM CARDCCI+4,1	\$4590017	
0C0032	0712			26	BC2 BCR 1,R2	\$4590018	
000034	07F2			27	BCR1 BCR 15,R2	\$4590019	
				28	EOJ EQU	\$4590020	
				29	** 360N-CL-453 EQU CHANGE LEVEL 3-0		
000036	CA0E			30	EOJ SVC 14		
000038	4040404040404040			31	IN DC CL80*	\$4590021	
000038	CCCCC01000000001			32	SYMA DC 2F'1'	\$4590022	
000050	CC0C0000			33	SYMB DC F'0'	\$4590023	
000094	CC0C0000			34	SYMC DC 2H'0'	\$4590024	
				35	CARDCCB CCB SYSIPT,CARDCCW	\$4590025	
				36	** 360N-CL-453 CCB CHANGE LEVEL 3-0		
L00098	0000			37	CARDCCB DC XL2'0' RESIDUAL CUUNT		
L0CC9A	CC0C			38	DC XL2'0' COMMUNICATIONS BYTES		
00009C	0000			39	DC XL2'0' CSM STATUS BYTES		
00009E	0C			40	DC AL1(0) LOGICAL UNIT CLASS		
0L009F	01			41	DC AL1(1) LOGICAL UNIT		
0000A0	00			42	DC XL1'0'		
0000A1	C000A8			43	DC AL3(CARDCCW) CCW ADDRESS		
G000A4	C0			44	DC B'00000000' STATUS BYTE		
G00CA5	CC0000			45	DC AL3(0) CSM CCW ADDRESS		
0000A8	G200G0382C0G0050			46	CARDCCW CCW 2,IN,32,80	\$4590026	
C00000				47	END HERE	\$4590027	
GCC0B0	C00C0098			48	=A(CARDCCB)		

RELOCATION DICTIONARY

PUS-ID	REL-ID	FLAGS	ADDRESS
01	01	08	0000A1
01	01	08	0000A9
01	01	0C	0000B0

Figure 43. SYSLST Output for Autotest Sample Problems (Part 1 of 4)

```

                                CROSS-REFERENCE

SYMBOL  LEN  VALUE  DEFN
BAL1    0C0C4 0C00C2 0009
BLK1    0C0C2 000034 0C27
BL1     0C0C4 000016 0013
BL2     0C0C2 000032 0026
CARDCCB 0C002 000058 0037   0017 0021 0025 0048
CARDCCM 0C008 0000A8 0046   0043
CHAN    00004 00001A 0C17
CSECT1  0C0C1 000000 0003
ECJ     0C0C2 000036 0030
HERE    000C2 0000C0 0007   0013 0047
IN      0C0C0 000038 0031   0010 0011 0046
MVC1    000C6 000006 0010
MVC2    0C0C6 00000C 0011
READ    00001 00001A 0014   0009
R10     0C0C1 00000A 0006   00C7 0008
R2      000C1 000002 0004   0009 0026 0027
R3      00001 000003 0005   0012
SYMA    0C0C4 000088 0032   001C
SYMB    0C0C4 000090 0033
SYML    0C002 000094 0034   0011 0012
TEST2   0C0C4 00002E 0025
THERE   0C0C4 000012 0012
WAIT1   0C0C4 0C0020 0021

NO STATEMENTS FLAGGED IN THIS ASSEMBLY

// EXEC ATLEDT

JOB  AUTOTEST          AUTOTEST DISK LINKAGE EDITOR DIAGNOSTIC OF INPUT
ACTION TAKEN  MAP
LIST          PHASE AAAAAAAA,S          $4590002
LIST  ENTRY

          PHASE  XFR-AD  LCCCKE  HICORE  DSK-AD  ESD TYPE  LABEL  LOADED  REL-FR
          AAAAAAA 00200C  002000  0020B3  21 5 2  CSECT  CSECT1  002000  002000

SVC= TR=          CARD-IMAGE          PPA-TPA  ERROR/S
      -/ PHQ AAAAAAAA
      -/ CSW CSECT1
254   -/ ADD THERE-6,40          00200C
      -/ EXC BL2,2          002032
255   -/ *4710A034
      -/ LUN SYMA,2          002088
      -/ *000G000000000000
252   001 -/ TK THERE,,DPL,SYMA,SYMC+3,,C,G          C          002012
      002 -/ DSP,IN+75,IN+76,(2,4,2),B
      -/ PLC AMS,AMS,2000

```

Figure 43. SYSLST Output for Autotest Sample Problems (Part 2 of 4)

// EXEC

```
TEST REQUEST ID 001 UN 00001
REGO 0000F890 00002098 9C002006 00002000 0000FF8C 0000FC15 A000213C C0000002
REG8 00000043 0C000000 50002002 00002000 0C002C38 00003C38 00000180 00C0008B
002088 G O O 1 0 0 0 1 A A A A

TEST REQUEST ID 001 UN 00002
REGO 0000F890 00002098 8C002006 FFFFC1C1 0000FF8C 0000FC15 A000213C 00000002
REG8 00000043 00000000 5C002002 00002000 00002C38 00003C38 00000180 0000008B
002C88 C O O 2 0 0 0 2 B B B B

TEST REQUEST ID 002 UN 00002
002083 C2C2
B B

TEST REQUEST ID 001 UN 00003
REGO 0000F890 0C002098 80002006 FFFFC2C2 0000FF8C 0000FC15 A000213C C0000002
REG8 00000043 00000000 50002002 00002000 00002C38 00003C38 00000180 0000008B
002088 C O O 3 0 0 0 3 C C C C

TEST REQUEST ID 001 UN 00004
REGO 0000F890 0C002098 80002006 FFFFC3C3 0000FF8C 0000FC15 A000213C C0000002
REG8 00000043 0C000000 5C002002 00002000 00002C38 00003C38 00000180 0000008B
002088 O O O 4 0 0 0 4 D D D D

TEST REQUEST ID 002 UN 00004
002083 C4C4
D D

TEST REQUEST ID 001 UN 00005
REGO 0C00F890 00002098 8C002006 FFFFC4C4 0C00FF8C 0000FC15 A000213C 00000002
REG8 00000043 0C000000 50002002 00002000 00002C38 00003C38 00000180 0000008B
002088 C O O 5 0 0 0 5 E E E E
```

LIST OF PHASE-NAMES

AAAAAAA FETCH 002000 002083

```
NORMAL END OF JOB
USER PSM - FF150C0E700C2038

GR 0-7 0000F890 00002098 80002006 FFFFC5C5 0000FF8C 0000FC15 A000213C 00000002
GR 8-F 00000043 00000000 50002002 00002000 00002C38 00003C38 00000180 0000008B
FR 0-6 4131998D1F000000 4152350604000000 8E7C2000E9886200 0000000000000000

CUMREL F0F161F0 F161F6F8 20002000 00000000 00000000 00000000 C1E4E3D6 E3C5E2E3 0000FFFF 000020B3 00002083 0000
```

Figure 43. SYSLST Output for Autotest Sample Problems (Part 3 of 4)

-LABEL LENGTH- 0000											
S2	BAL1			MVC1	MVC2		THERE	BCL	READ		
S1	CSECT1			A0180203	A086A040	GAFE0700	002010	07000AFC	070047F0	A0005810	AOAE0A00
CH	05A04520			K					0		
MN	BALR&AL			MVC		SVC BCR		BCR SVC	BCR BC	L	SVC
S2	WAIT1					TEST2		BC2	EOJ		
S1	5810A0AE	91801002	4710A02C	0A079101	002030	A09A0AFD	BCR1	BCR1	IN	615C4040	40404040
CH	002020						07F20A0E	2	/ *		
MN	L	TM LPR	BC	SVC TM		SVC	BCR SVC		STH	STH	STH
CH	002040	40404040	40404040	40404040	002050	40404040	40404040	40404040	40404040	40404040	
MN	STH	STH	STH	STH	STH	STH	STH	STH	STH	STH	STH
CH	002060	DITTO									
CH	00FFA0	07C1FF00	22FC120C	0002C1C1	C1C1C1C1	00FFB0	C1C11200	04001200	04101400	09001400	
MN	A	BCR	LTURLTR	A A	A A A A	A A	LTR	SPM LTR	SPM NR	ISK NR	
CH	00FFC0	09011400	02000000	20830020	38090000	00FFD0	00000100	00000000	00FF0000	20B30000	
MN	ISK NR		LPDR	LER						LPDR	
CH	00FFE0	12000100	12000103	12000200	12000201	00FFF0	12000300	12000300	00000000	00000000	
MN	LTR	LTR	LTR	LTR		LTR	LTR				
END											
EOJ AUTOTEST											

Figure 43. SYSLST Output for Autotest Sample Problems (Part 4 of 4)

Multiprogramming

Multiprogramming capabilities are demonstrated by the multiprogramming sample problem. A control program supporting multiprogramming is required. A card-to-printer utility macro lists fifteen test cards containing the instructions and necessary operator commands to initiate the job in the foreground-one (F1) area. The card-to-printer utility macro is first cataloged and then assembled and executed as a background job. The fifteen test cards are listed on the printer. When the last card in the reader has been read and processed, the following message will be printed on SYSLOG:

```
OP08A INTERV REQ SYSRDR ...
```

To clear the intervention required condition on the reader, the operator should enter the following two cards in the reader and ready the device:

```
/E
```

```
// PAUSE REFER TO PRINTER FOR ADDITIONAL INSTRUCTIONS
```

The operator can now initiate this same program in the foreground area by following the instructions previously listed on SYSLST when the job was run in the background problem area.

The same data previously used for the background execution (fifteen test cards) is used as input data for the foreground execution. The data cards must, therefore, be removed from the card reader output stacker and they must be replaced in the input hopper. Then the card reader is made ready. The operator should now follow the instructions contained in the test data to initiate the job in the foreground area.

Several assumptions have been made in the multiprogramming sample problem. The first assumption is that a foreground-one area has previously been allocated. If this has not been done, the operator should refer to the DOS Operating Guide referenced on the cover of this publication.

The second assumption is that SYSRDR or SYSIPT is assigned to 00C and SYSIST assigned to 00E and that there are no other logical units assigned to these devices. If this is not the case, message

1A13D CONFLICTING I/O ASSIGNMENTS

will be issued on SYSLOG when the operator tries to initiate the program in the foreground area. To recover from this condition, the operator should reply CANCEL to the preceding message. The message

F1 0S02I JOB FG INIT. CANCELED DUE TO PROGRAM REQUEST

will then be issued. The operator should then press the Request key on the 1052-Printer-Keyboard. The message

1I60A READY FOR COMMUNICATIONS

will be issued. The operator should next enter the START command followed by

ASSGN SYSxxx,UA

where xxx is the unit(s) retaining a background assignment for the indicated device. The operator can now initiate the job in the foreground-one area as previously described. To execute the multiprogramming sample problem the following cards must be entered:

```
// JOB CATALOG SAMPLE FOREGROUND/BACKGROUND PROGRAM
// OPTION CATAL
  PHASE CARDPRNT,+0
// EXEC ASSEMBLY
  Column 10
  PRINT NOGEN
  START 0
  INCARD
  OUTPRT BUFSIZ=80
  END

/*
// EXEC LNKEDT
// &
// JOB EXECUTE SAMPLE FOREGROUND/BACKGROUND PROGRAM
// ASSGN SYS001,X'00C'          (Note 1)
// ASSGN SYS002,X'00E'          (Note 2)
// PAUSE CARD READER END-OF-FILE SIGNALS END OF CARD INPUT
// EXEC CARDPRNT
* THESE COMMENTS AND THE FOLLOWING STATEMENTS ARE TEST INPUT
* NOW IN A PAUSE STATUS, UNASSIGN THE PRINTER (X'00E') AND THE CARD
* READER (X'00C') TO PERMIT SUBSEQUENT ASSIGNMENT TO FOREGROUND
* AREA. TO DO THIS, TYPE THE FOLLOWING
ASSGN SYSRDR,UA
ASSGN SYSIPT,UA                      (Note 3)
ASSGN SYSIST,UA
* TO SUSPEND BACKGROUND (BG) AREA PROCESSING TYPE
STOP
* TO INITIATE PROGRAM NAMED CRDPRNT IN FOREGROUND1 (F1) AREA,
* THE FOLLOWING FOUR STATEMENTS ARE TO BE TYPED ON SYSLOG (1052)
START F1                              (Note 4)
ASSGN SYS001,X'00C'                    (Note 1)
```

ASSGN SYS002,X'00E'
EXEC CARDPRNT

(Note 2)

Note 1: SYS001 must be assigned to a card reader.

Note 2: SYS002 must be assigned to a printer.

Note 3: These cards are required only if SYS001 or SYS002 retain a background assignment. A device used by a foreground program cannot be assigned to a background area at the same time.

Note 4: This command is processed by the ATTN routine (Refer to DOS Operating Guide referenced on the cover of this publication.)

The test cards for the multiprogramming sample problem are output on SYS002, which was previously assigned to the system printer. LOG must be keyed on the 1052 Printer-Keyboard at the beginning of the job to obtain a complete listing of all job control cards and messages. The SYSLOG output is shown in Figure 18. The SYSLST output in Figure 44 contains:

- Job control cards
- External symbol dictionary
- Source program listing
- Relocation dictionary
- Diagnostics
- Linkage editor storage map
- List of test cards processed by card-to-printer utility program

```
// JOB CATALOG SAMPLE FCREGROUND/BACKGROUND PROGRAM
// OPTION CATAL
// PHASE CARDPRINT,+0
// EXEC ASSEMBLY
```

EXTERNAL SYMBOL DICTIONARY						PAGE 1
SYMBOL	TYPE	ID	ADDR	LENGTH	LD ID	
PC	01	000C00	00034A			

SOURCE STATEMENT						PAGE 1
LOC	OBJECT CODE	ADDR1	ADDR2	STMT	SOURCE STATEMENT	
000000				1	PRINT NOGEN	
				2	START 0	
				3	INCARD	
				109	OUTPRT BUFSIZ=80	
				237	END	

RELOCATION DICTIONARY				PAGE 1
POS.ID	REL.ID	FLAGS	ADDRESS	
01	01	CC	000050	
01	01	C8	0000C1	
01	01	C8	0000C9	
01	01	C8	0000D9	
01	01	C8	0000E1	
01	01	CC	0001CC	
01	01	C8	000269	
01	01	C8	000271	
01	01	C8	000281	
01	01	C8	000289	
01	01	C8	000299	
01	01	C8	0002A1	

Figure 44. SYSLST Output for Multiprogramming Sample Problems (Part 1 of 5)

				CRGSS-REFERENCE										PAGE 1									
SYMBOL	LEN	VALUE	DEFN																				
CDA0001	00004	000004	0009	0030	0044	0046	0093																
CDAG0001	00004	000050	0030	0014	0028																		
CDAD0001	00080	00000C	0032	0056																			
CDAE0001	00080	00005C	0033	0066																			
CDAF0001	00002	000080	0043	0099	0102	0104																	
CDAG0001	00002	000084	0045	0103																			
CDAH0001	00002	000088	0047	0016	0018	0044																	
CDAJ0001	00008	0000C8	0056	0019	0021	0053																	
CDAK0001	00002	000000	0057	0022	0024	0046																	
CDAL0001	00008	0000EC	0066	0025	0027	0063																	
CDAN0001	00004	0000F8	0069	0015	0029	0096																	
CDAP0001	00004	00010C	0071	0097																			
CDAQ0001	00004	00010A	0074	0072																			
CDAR0001	00004	00011E	0080	0075																			
CDAS0001	00004	00012E	0084	0079																			
CDAT0001	00004	000160	0099	0069	0083																		
CDAU0001	00002	000166	0101																				
CDBA0001	00004	00000C	0011	0031																			
CDBM0001	00004	000158	0098	0084	0085	0091	0092																
CDCM0001	00004	0000E8	0067	0012	0095	0106																	
CDEN0001	00004	00017E	0106	0087																			
CDRE0001	00002	00013C	0089	0010																			
CDRZ0001	00004	00014E	0096	0070	0078																		
CDK00001	00001	00000G	0034	0076	0076	0081																	
CDR10001	00001	000001	0035	0071	0074	0080	0084	0086	0091	0099	0100												
CDR20001	00001	000002	0036	0012	0013	0014	0017	0020	0023	0026	0077	0077	0080	0081	0082	0086	0095	0106					
CDR30001	00001	000003	0037	0016	0017	0018	0019	0020	0021	0022	0023	0024	0025	0026	0027	0069	0083	0105					
CDR40001	00001	000004	0038	0102	0103																		
CDR50001	00001	000005	0039	0012	0095	0102	0104	0106															
CDSW0001	00004	000008	0010	0011																			
CDXX0001	00001	00017A	0108																				
CD140001	00001	00000E	0040	0087																			
CD150001	00001	0000CF	0041	0007	0008	0009	0009	0013	0028	0085	0089	0090	0092	0093	0094	0094	0100	0107					
PRAA0002	00004	00017C	0115	0138	0153	0154																	
PRA00002	00004	000188	0118	0139																			
PRA00002	00004	0001CC	0138	0120																			
PRAE0002	00080	000188	0140	0163																			
PRAF0002	00080	0001D8	0141	0171																			
PRAH0002	00004	000238	0153	0200	0202	0203																	
PRAJ0002	00004	00023C	0154	0189	0201	0228																	
PRAK0002	00004	000240	0155	0116	0224	0231																	
PRAQ0002	00082	0002AC	0184	0117	0121	0137																	
PRAR0002	00004	0002C0	0191																				
PRAU0002	00001	0002DC	0199	0195																			
PRAV0002	00004	0002E8	0203																				

Figure 44. SYSLST Output for Multiprogramming Sample Problems (Part 2 of 5)

CROSS-REFERENCE													PAGE 2					
SYMBOL	LEN	VALUE	DEFN															
PRAW0002	00001	00031E	0216	0207														
PRA20002	00004	0C031A	0218															
PRB10002	00006	000260	0156	0122	0124	0154												
PRB20002	00006	000278	0164	0125	0127	0153												
PRB30002	00006	00029C	0172	0134	0136	0196												
PRDA0002	00004	0C0320	0220															
PRDB0002	00006	0C0324	0221	0220														
PRDC0002	00002	0C032A	0222															
PRDD0002	00004	00032E	0224	0187	0233													
PRDE0002	00001	0C0334	0227	0185														
PREM0002	00008	00C23C	0152	0212														
PRENG002	00001	00034A	0236															
PRFB0002	00004	0002A8	0182	0206														
PRMH0002	00004	000228	0151	0210	0214													
PRSV0002	00002	00032C	0223															
PRSW0002	00004	000184	0117	0118														
PRS10002	00004	0002FA	0208	0209														
PRS30002	00004	000314	0215	0208														
PRT90002	00004	0C02CA	0194															
PRWA0002	00008	000270	0163	0128	0130	0160												
PRWB0002	00008	000288	0171	0131	0133	0168												
PRW10002	00001	0C02A0	0179															
PRW200C2	00001	0002AC	0180															
PRW30002	00008	0002A0	0181	0176	0197													
PRO00002	00001	0C0000	0142	0184	0184	0210	0211	0214	0217									
PRO10002	00001	C00001	0143	0186	0186	0188	0189	0190	0191	0194	0196	0210	0212	0214	0217	0221	0222	0228
				0229	0230	0231	0232	0232										
PRO20002	000C1	C00002	0144	0119	0120	0123	0126	0129	0132	0135	0188	0206	0215	0218	0219	0220		
PRO30002	00001	000003	0145	0122	0123	0124	0125	0126	0127	0128	0129	0130	0131	0132	0133	0134	0135	0136
PRO40002	00001	C000C4	0146	0116	0224													
PR130002	000C1	C00000	0147	0116	0200	0201	0205	0221	0224									
PR140002	00001	00000E	0148	0200	0202	0203	0204	0205	0218	0222	0225							
PR150002	00001	C0000F	0149	0113	0114	0115	0115	0119	0190	0204	0229	0235						
NO STATEMENTS FLAGGED IN THIS ASSEMBLY																		

Figure 44. SYSLST Output for Multiprogramming Sample Problems (Part 3 of 5)

```

// EXEC LNKEDT

JOB CATALOG          DISK LINKAGE EDITOR DIAGNOSTIC OF INPUT
ACTION TAKEN        MAP
LIST PHASE CARUPRNT,+0
LIST ENTRY

      PHASE  XFR-AD  LUCORE  HICORE  DSK-AD  ESD TYPE  LABEL      LOADED  REL-FR
      CARDPRT 000000  000000  000349  28 0 1  CSECT      000000  000000

SYSTEM DIRECTORY          CORE-IMAGE          RELOCATABLE          SOURCE-STATEMENT
-----
                                C H R E          C H R E          C H R E
DIRECTORY STARTING ADDRESS    01 00 01          64 00 01          101 00 01
DIRECTORY NEXT ENTRY         01 02 07 11          64 01 02 00          101 00 14 06
DIRECTORY LAST ENTRY         01 04 08 17          64 04 09 22          101 01 16 09

LIBRARY STARTING ADDRESS     01 05 01          64 05 01          101 02 01
LIBRARY NEXT AVAILABLE ENTRY  43 00 02          83 08 09          142 06 07
LIBRARY LAST AVAILABLE ENTRY  63 09 02          100 09 09          149 09 16

-----STATUS INFORMATION-----
DIRECTORY ENTRIES ACTIVE     403                230                136
LIBRARY BLOCKS ALLCCATED    1250                3285                7808
LIBRARY BLOCKS ACTIVE       827                1745                6630
LIBRARY BLOCKS DELETED       04                 00                 00
LIBRARY BLOCKS AVAILABLE    419                1540                1178

AUTOMATIC CONDENSE LIMIT     00                 4000                6000

LIBRARY ALLOCATED CYLINDERS   63                 37                 49
DIRECTORY ALLOCATED TRACKS    05                 05                 02

EDJ CATALOG

```

Figure 44. SYSLST Output for Multiprogramming Sample Problems (Part 4 of 5)

```

// JOB EXECUTE SAMPLE FCREGROUND/BACKGROUND PROGRAM
// ASSGN SYS001,X'00C' CARD READER
// ASSGN SYS002,X'00E' PRINTER
// PAUSE CARD READER END-OF-FILE SIGNALS END OF CARD INPUT
// EXEC CARDPRNT

```

```

* THESE COMMENTS AND THE FOLLOWING STATEMENTS ARE TEST INPUT
* NOW IN A PAUSE STATUS, UNASSIGN THE PRINTER (X'00E') AND THE CARD
* READER (X'00C') TO PERMIT SUBSEQUENT ASSIGNMENT TO FOREGROUND
* AREA. TO DO THIS, TYPE THE FOLLOWING
ASSGN SYSRDR,UA (REQUIRED ONLY IF SYSRDR ASSIGNED TO X'00C')
ASSGN SYSIPT,UA (REQUIRED ONLY IF SYSIPT ASSIGNED TO X'00C')
ASSGN SYSLSST,UA (REQUIRED ONLY IF SYSLSST ASSIGNED TO X'00E')
* TO SUSPEND BACKGROUND (BG) AREA PROCESSING, TYPE
STOP
* TO INITIATE PROGRAM NAMED CARDPRNT IN FOREGROUND 1 (F1) AREA, THE
* FOLLOWING FOUR STATEMENTS ARE TO BE TYPED ON SYSLOG (1052)
START F1 (THIS COMMAND IS PROCESSED BY THE 1052 ATTENTION ROUTINE)
ASSGN SYS001,X'00C' CARD READER
ASSGN SYS002,X'00E' PRINTER
EXEC CARDPRNT

```

```

EOJ EXECUTE

```

```

// PAUSE REFER TO PRINTER FOR ADDITIONAL INSTRUCTIONS
ASSGN SYSRDR,UA
ASSGN SYSIPT,UA
ASSGN SYSLSST,UA

```

```

* THESE COMMENTS AND THE FOLLOWING STATEMENTS ARE TEST INPUT
* NOW IN A PAUSE STATUS, UNASSIGN THE PRINTER (X'00E') AND THE CARD
* READER (X'00C') TO PERMIT SUBSEQUENT ASSIGNMENT TO FOREGROUND
* AREA. TO DO THIS, TYPE THE FOLLOWING
ASSGN SYSRDR,UA (REQUIRED ONLY IF SYSRDR ASSIGNED TO X'00C')
ASSGN SYSIPT,UA (REQUIRED ONLY IF SYSIPT ASSIGNED TO X'00C')
ASSGN SYSLSST,UA (REQUIRED ONLY IF SYSLSST ASSIGNED TO X'00E')
* TO SUSPEND BACKGROUND (BG) AREA PROCESSING, TYPE
STOP
* TO INITIATE PROGRAM NAMED CARDPRNT IN FOREGROUND 1 (F1) AREA, THE
* FOLLOWING FOUR STATEMENTS ARE TO BE TYPED ON SYSLOG (1052)
START F1 (THIS COMMAND IS PROCESSED BY THE 1052 ATTENTION ROUTINE)
ASSGN SYS001,X'00C' CARD READER
ASSGN SYS002,X'00E' PRINTER
EXEC CARDPRNT

```

Figure 44. SYSLSST Output for Multiprogramming Sample Problems (Part 5 of 5)

Magnetic Character Readers

The first 1412/1419 Magnetic Character Reader sample problem processes 500 documents from one magnetic character reader using GET logic. The documents are read into pocket 3 in groups of approximately 50. After each group is read, the 1412/1419 Magnetic Character Reader is disengaged, the batch number is updated, and the pocket light is turned on. All documents are listed on the printer. If the Selective Tape List feature is present on the printer, the documents are listed on the leftmost tape. The controls on the magnetic character reader that must be depressed, if present, are: BATCH NUMBER ON, PROG SORT, and at least one field for the VALIDITY CHECK & READ OUT control.

The second 1412/1419 Magnetic Character Reader sample problem processes 250 documents from each of two magnetic character readers, (both of the same type: both with a single address adapter or both with a dual address adapter), using READ, CHECK, and WAITF logic. The only controls that must be depressed are PROG SORT and at least one field for the VALIDITY CHECK, & READ OUT control. Documents from one reader are selected into pockets one or zero depending on whether or not the selected field is present. Documents read in error are rejected and all data is listed on a printer. If the Selective Tape List feature is present on the printer, data is printed on the leftmost tape.

Documents from the second reader are selected according to a digit in the field read and printed on SYSLST. If manual intervention is required on the second reader, a message is printed on SYSLOG. The message is:

INTERVENTION REQUIRED ON FILE2.

The program names are Z.MCR1 and Z.MCR2. The 1412/1419 sample problems support the 1259.

Instructions show how to remove the following optional features:

1. Dual addressing adapter feature
2. Batch numbering
3. Pocket lights
4. Selective Tape List Feature (Printer)

The SYSLOG output is shown in Figure 17. The SYSLST output in Figure 45 contains:

- Job control cards
- External symbol dictionary
- Source program listing
- Relocation dictionary
- Linkage editor input diagnostics
- Linkage editor storage map
- Document data listings
- EQJ MCR
- // PAUSE END OF MCR SAMPLE PROBLEMS

```
// JOB MCR SAMPLE PROBLEMS
// ASSGN SYS005,X'004'
// ASSGN SYS006,X'005'
// ASSGN SYS009,X'012'
// OPTION LINK,NXREF
// EXEC ASSEMBLY
```

```
EXTERNAL SYMBOL DICTIONARY PAGE 1
SYMBOL TYPE ID ADDR LENGTH LD ID
PC 01 00000 002834
IJUDZZZZ FR 02
IJUDZZZZ SD 03 002838 0004BC
IJDFSZZZ FR 04
IJDFSZZZ SD 05 002838 00002R
```

```
$477 MCR1 SAMPLE PROBLEM PAGE 1
DOS CL3-C C3/12/69
LOC OBJECT CODE ADDR1 ADDR2 STMT SOURCE STATEMENT
000000 0540 2 PRINT NOGEN L4770002
000002 3 START BALR 4,C L4770003
4 USING *+4 L4770004
5 OPEN FILE1,FILE OPEN ALL FILES L4770005
14 L DUCNT,TOTDOC INITIALIZE DOCUMENT COUNTER L4770006
15 NEXT GET FILE GET DOCUMENT FROM MICR DEVICE L4770007
20 20 TM DISSW,X'01' DISENGAGE L4770008
00002A 4710 4066 002AE 21 BD DISFNG YES L4770009
00002E 9110 2000 00000 22 DISCCM TM C(2),X'10' READY FOR POCKET LIGHT L4770010
000032 4710 407E 00080 23 BD LITE YES L4770011
000036 9108 2000 00000 24 TM C(2),X'08' IF INT. KEYS... RE-ISSUE GET L4770012
00003A 4710 4018 0001A 25 BD NXFT L4770013
00003E 4650 4044 00046 26 LASDOC BCT DUCNT,MVC DECREMENT DOCUMENT COUNTER L4770014
000042 47F0 4092 00094 27 B EOF L4770015
000046 0209 422F 2C56 00230 00056 28 MVC MVC AREA(10),8(2) MOVE DATA TO OUTPUT AREA L4770016
29 PUT FILE1,STLSP=BKT PRINT L4770017
37 * OMIT 'STLSP=BKT' PARAMETER IF SELECTIVE TAPE LIST FEATURE NOT PRESENT L4770018
38 B NEXT L4770019
39 DISENG DISEN FILE DISENGAGE MICR DEVICE L4770020
000074 9230 42A9 002AR 44 MVI CTR+1,X'3C' REINITIALIZE DOCUMENT COUNTER L4770021
000078 9200 42AC 002AF 45 MVI DISSW,X'00' RESET DISENGAGE SWITCH L4770022
00007C 47F0 402C 0002E 46 B DISCCM L4770023
000080 47 LITE EQU * L4770024
48 LITE FILE,SWAPEA LIGHT POCKET SPECIFIED IN SWAPEA L4770025
54 * REMOVE ABOVE STATEMENT IF POCKET LIGHT FEATURE IS ABSENT L4770026
55 B LASDOC L4770027
000090 47F0 403C 0003F 56 EOF MVC DISCCM+(2),EOJADD ALTER EOJ BRANCH L4770028
000094 D201 4032 409C 00034 0009E 57 B DISENG L4770029
00009A 47F0 4066 00068 58 EOJADD DC S(EQJ) EOJ ADCON L4770030
00009E 409E 59 EOJ CLOSE FILE1,FILE CLOSE ALL FILES L4770031
60 EOJ L4770032
71 * L4770033
72 * STACKFP SELECTION ROUTINE L4770034
73 * L4770035
74 * L4770036
0000B4 75 USSR MVI 4(7),X'3F' ARBITRARILY SELECT POCKET THREE L4770037
0000B8 4320 51F7 00004 002AB 76 IC 2,CTR+1 DECREMENT DOCUMENT COUNTER L4770038
0000BC 4620 5014 000C8 77 BCT 2,NODIS L4770039
0000C0 9601 51FA 002AE 78 DI DISSW,X'01' TURN ON DISENGAGE SWITCH L4770040
0000C4 9680 7001 00001 79 DI 1(7),X'RC' UPDATE BATCH NUMBERER L4770041
80 * REMOVE ABOVE STATEMENT IF BATCH NUMBERING NOT AVAILABLE L4770042
0000C8 4220 51F7 002AB 81 NODIS STC 2,CTR+1 L4770043
82 EXIT MR L4770044
83 DROP 5 L4770045
84 * L4770046
87 FILE DTFMR BUFFERS=100, XL4770047
EXTADDR=USSR, XL4770048
IOARFAL=AREA, XL4770049
DEVADDR=SYS005, XL4770050
RECSIZE=80, XL4770051
IDREG=2, XL4770052
```

Figure 45. SYSLST Output for 1412/1419 Sample Problems (Part 1 of 7)

LOC	OBJECT CODE	ADDR1	ADDR2	STMT	SOURCE STATEMENT	DOS CL3-0	03/12/69
					ADDRESS=DUAL, REMOVE IF DUAL ADAPTER NOT PRESENT	XL4770053	
					SFCADDR=SYSC06, REMOVE IF DUAL ADAPTER NOT PRESENT	XL4770054	
					ADDRESS=10	L4770055	
				157	MRMOD ADDRESS=DUAL, RUFFERS=100	L4770056	
				521 *	IF DUAL ADDRESSING ADAPTER FEATURE IS ABSENT,	L4770057	
				522 *	REMOVE (ADDRESS=DUAL) PARAMETER FROM THE ABOVE STATEMENT.	L4770058	
				523 FILF1	DTFPR DEVADR=SYSC06,	XL4770059	
					STLIST=YES, REMOVE IF NO SELECTIVE TAPE FEATURE PRESENT	XL4770060	
					IDARCA1=AREA1	L4770061	
				545	PRMOD	XL4770062	
					STLIST=YES, REMOVE IF NO SELECTIVE TAPE FEATURE PRESENT	XL4770063	
					RECFORM=FIXUNB	L4770064	
				613	LTORG	L4770065	
000210				614	=C' \$RDPEN '		
000210	5B5HC20E07C50540			615	=C' \$RCLOSE'		
000216	5B5HC20E07C50540			616	=A(FILE)		
000220	0C00C0C			617	=A(FILE)		
000224	0C00C108			618	=A(RKT)		
000228	0C00C2A9			619	=A(SWAREA)		
00022C	0000C2AC			620	DOCNT EQU 5	DOCUMENT COUNTER	L4770066
000005				621	AREAL DC 121CL1'	OUTPUT AREA	L4770067
000230	4040404040404040			622	BKT DC X'01'	SELECTIVE TAPE LISTER TAPE INDICATOR	L4770068
0002A9	01			623	CTR DC H'48'	DOCUMENT COUNTER	L4770069
0002AA	0030			624	SWARFA DC X'04C0'	POCKET SELECTION FOR POCKET LIGHTING	L4770070
0002AC	0400			625	DISSW DC X'00'	DISENGAGE SWITCH	L4770071
0002AF	00						
0002AF	00						
0002R0	0C0001F4			626	TOTDOC DC F'500'	TOTAL NO. OF DOCUMENTS TO BE READ	L4770072
000244				627	AREA DS CL9600	MICR INPUT AREA	L4770073
000300				628	END START		L4770074

RELOCATION DICTIONARY

POS.ID	REL.ID	FLAGS	ADDRESS
01	01	0C	00000C
01	01	0C	000010
01	01	0C	0000A6
01	01	0C	0000AC
01	01	0C	000098
01	02	18	0000F1
01	01	0C	000108
01	01	08	000129
01	01	08	000120
01	01	0C	000130
01	01	0C	000134
01	01	0C	000138
01	01	0C	000144
01	01	0C	00014C
01	01	0C	000150
01	01	0C	00015C
01	01	08	000171
01	01	08	000179
01	01	08	000181
01	01	08	000189
01	01	08	000191
01	01	08	000199
01	01	08	0001A1
01	01	08	0001A9
01	01	08	0001B1
01	01	08	0001B9
01	01	08	0001C1
01	01	08	0001C9
01	01	08	0001D1
03	03	08	002CA1
03	03	08	002CA9
01	01	0C	0001E0
01	04	18	0001E9
01	01	0C	0001F0
01	01	08	000201
01	01	08	000209
01	01	0C	000220
01	01	0C	000224
01	01	0C	000228
01	01	0C	00022C

Figure 45. SYSLST Output for 1412/1419 Sample Problems (Part 2 of 7)

```

// EXEC LNKEOT

JOB MCR                                DISK LINKAGE EDITOR DIAGNOSTIC OF INPUT
ACTION TAKEN MAP
LIST ENTRY

06/19/68 PHASE XFR-AD LOCURE HICURE DSK-AD ESD TYPE LABEL LOADED REL-FR
          PHASE*** 004000 004000 006C9F 15 04 3 CSECT          004C00 004000
                                         CSECT      IJUDZZZZ 006830 004000
                                         CSECT      IJDFSZZZ 006C78 004000

// EXEC

000009437$
000529816$
000002642$
000009437$
000009437$
000529816$
000009437$
000009437$
000002642$
000002642$
000002642$
000009437$
NOTE: This is a portion of the tape output for MCRI.
000002642$
000002642$
000002642$
000002642$
000002642$
000002642$
000002642$
000002642$
000002642$
000002642$
000002642$
000009437$

000009437$
000529816$
000009437$
000002642$
000002642$
000002642$
000002642$
000002642$
000002642$
000002642$
000002642$
000002642$
000002642$
000002642$
000002642$
000009437$

```

Figure 45. SYSLST Output for 1412/1419 Sample Problems (Part 3 of 7)

```
// PAUSE END OF MCR1
// ASSGN SYS007,X'006'
// EXEC ASSEMBLY
```

```
SYMBOL TYPE ID ADDR LENGTH LD ID          EXTERNAL SYMBGL DICTIONARY          PAGE 1

      PC 01 00C000 003928
IJUJZZZZ ER 02
IJDFSZZZ ER 03
IJDFZZZZ FR 04
IJUJZZZZ SD 05 003928 00048C
IJDFSZZZ SD 06 003008 000928
IJDFZZZZ SD 07 003F00 00002R
IJZAO026 SD 08 003E28 00001A
```

```
$477 MCR2 SAMPLE PROBLEM          PAGE 1

LOC OBJECT CODE  ADDR1 ADDR2  STMT  SOURCE STATEMENT          005 CL3-0 C3/12/69

      2          PRINT NOGEN          $47700C2
000000 0540      3 START  BALR 4,0          $4770003
000002          4          USING *4          $4770004
      5          OPEN FILE1,FILE2,FILE3,FILE4 OPEN ALL FILES $4770005
      16         L DOCNT1,TUT00C INITIALIZE FILE1 DOCUMENT COUNTER $4770006
      17         LR DOCNT2,DOCNT1 INITIALIZE FILE2 DOCUMENT COUNTER $4770007
      18 NEXT    READ FILE1,MR        GET DOCUMENT FROM FIRST MICR DEVICE $4770008
      23         CHECK FILE1,NEXT1    IS DOCUMENT READY FOR PROCESSING $4770009
000040 465C 404E      29         BCT DOCNT1,MVC1    DECREMENT DOCUMENT COUNTER FOR FILE1 $4770010
      30         DISEN FILE1          DISENGAGE FILE1          $4770011
000050 D209 447E 2C10 00480 00310 35 MVC1    MVC AREA(10),16(2) MOVE DATA TO OUTPUT AREA $4770012
      36         PUT FILE3,STLSP=CNTAD1 PRINT $4770013
      44 * OMIT * STLSP=CNTAD1* PARAMETER IF NO SELECTIVE TAPE FEATURE $4770014
      45 NEXT1    READ FILE2,MR        GET DOCUMENT FROM SECOND MICR DEVICE $4770015
      50         CHECK FILE2,NEXT2    IS DOCUMENT READY FOR PROCESSING $4770016
00008A 4660 4098      56         BCT DOCNT2,MVC2    DECREMENT DOCUMENT COUNTER FOR FILE2 $4770017
      57         DISEN FILE2          DISENGAGE FILE2          $4770018
00C09A D263 45CA 3006 0050C 00006 62 MVC2    MVC PRNTAR(10C),6(3) MOVE DATA TO OUTPUT AREA $4770019
      63         PUT FILE4          PRINT $4770020
      68 NEXT2    WAITF FILE1,FILE2    ANY MICR FILES ACTIVE $4770021
      77         B NEXT              YES $4770022
0000CC 47F0 4022      78 ERROUT1 LR 14,0          INITIALIZE RETURN REGISTER $4770023
0000C4 18E0      79         TM 0(2),X'3C' UNRECOVERABLE I/O ERROR OR ALL DOCS PROCESSED $4770024
0000C6 9130 2000      80         BNZ CLOSE1          YES $4770025
0000CA 4770 40FE      81         BR 14          RETURN TO NEXT READ $4770026
0000CE 07FE      82 ERROUT2 LR RETURN,C      INITIALIZE RETURN REGISTER $4770027
0000D0 18A0      83         TM 0(3),X'30' UNRECOVERABLE I/O ERROR OR ALL DOCS PROCESSED $4770028
0000D2 9130 3000      84         BNZ CLOSE2          YES $4770029
0000D6 4770 4106      85         TM 0(3),X'08' INTERVENTION REQUIRED $4770030
0000DA 9108 3000      86         BCR 14,RETURN    NO $4770031
0000DE 07FA      87         PUT MSGWRT          $4770032
0000E0 07FA      92         BR RETURN          $4770033
      93 CLOSE1  CLOSE FILE1          CLOSE FILE1 $4770034
0000FE 9601 446F      101        DI CLOSID,X'C1' SET FILE1 CLOSED INDICATOR $4770035
000102 47F0 4118      102        B ENDTST          $4770036
      103 CLOSE2  CLOSE FILE2          CLOSE FILE2 $4770037
000116 9602 446F      111        DI CLOSID,X'02' SET FILE2 CLOSED INDICATOR $4770038
00011A 9103 446F      112 ENDTST  TM CLOSID,X'C3' BOTH FILES CLOSED $4770039
00011E 47E0 4022      113        BNO NEXT          NO $4770040
      114        CLOSE FILE3,FILE4    CLOSE PRINTER FILES $4770041
      123        EOJ $4770042
      126 * $4770043
      127 * STACKER SELECTION ROUTINE FOR FILE1 $4770044
      128 * $4770045
000138          USING *5 $4770046
000138 910C 7002      129        BR 2(7),X'0C' DATA CHECK OR OVERRUN $4770047
00013C 4770 5022      131        BNZ DERR1          YES $4770048
000140 D509 533A 7010 C0472 00010 132        CLC BLANK(10),16(7) IS FIELD BLANK $4770049
000146 4770 501A      133        BNE PKT1          NO $4770050
00014A 920F 7CC4      134        MVI 4(7),X'0F' SELECT POCKET ZERO $4770051
00014E 47F0 5026      135        B EXIT1          $4770052
```

Figure 45. SYSLST Output for 1412/1419 Sample Problems (Part 4 of 7)

\$477 MCR2 SAMPLE PROBLEM						PAGE 2
LOC	OBJECT CODE	ADDR1	ADDR2	STMT	SOURCE STATEMENT	DOS CL3-C 03/12/69
000152	921F 7004	00004		136	PKT1 MVI 4(7),X*1F*	SELECT POCKET ONE \$4770053
000156	47F0 5026		0015E	137	B EXIT1	\$4770054
00015A	92CF 7004	00004		138	DFERR1 MVI 4(7),X*CF*	SELECT REJECT POCKET \$4770055
				139	EXIT1 MR	\$4770056
				142	*	\$4770057
				143	*	\$4770058
				144	*	\$4770059
				145		\$4770060
000160				146	USSR2 TM 2(7),Y*CC*	DATA CHECK OR OVERRUN \$4770061
00016C	910C 70C2	00002		147	BNZ REJECT	YES \$4770062
000164	4770 5C22		00182	148	CLI 98(7),X*F9*	\$4770063
000168	95F9 7C62	00062		149	SH REJECT	\$4770064
00016C	4720 5022		00182	150	CLI 98(7),X*FC*	IS DATA A DIGIT \$4770065
000170	95F0 7062	00062		151	BL REJECT	\$4770066
000174	4740 5022		00182	152	PACK 4(1,7),98(1,7)	SELECT POCKET ACCORDING DIGIT ON 'DNC. \$4770067
000178	F200 70C4	7062	00004	153	B EXIT2	\$4770068
00017E	47F0 5026		00186	154	REJECT MVI 4(7),X*CF*	SELECT REJECT POCKET \$4770069
000182	92CF 7004	00004		155	EXIT2 EXIT MR	\$4770070
				158	OROP 5	\$4770071
				159	*	\$4770072
				160	FILE1 DTFMR DEVADDR=SYSC05,	\$4770073
					ADDRESS=DUAL, REMOVE IF DUAL ADDRESSING ADAPTER ABSENT	\$4770074
					ADDAREA=C,	\$4770075
					IORFG=2,	\$4770076
					IQAREA1=AREA1,	\$4770077
					RECSIZE=20,	\$4770078
					ERROPT=ERROUT1,	\$4770079
					EXTADDR=USSR1,	\$4770080
					SECADDR=SYSC06, REMOVE IF DUAL ADDRESS ADAPTER ABSENT	\$4770081
					BUFFERS=100	\$4770082
				230	FILE2 DTFMR DEVADDR=SYSC07,	\$4770083
					ADDRESS=DUAL, REMOVE IF DUAL ADDRESSING ADAPTER ABSENT	\$4770084
					RECSIZE=80,	\$4770085
					IQAREA1=AREA2,	\$4770086
					IORFG=3,	\$4770087
					ADDAREA=20,	\$4770088
					BUFFERS=100,	\$4770089
					ERROPT=ERROUT2,	\$4770090
					SECADDR=SYSC08, REMOVE IF DUAL ADDRESS ADAPTER ABSENT	\$4770091
					EXTADDR=USSR2	\$4770092
				300	FILE3 DTFPR DEVADDR=SYSC09,	\$4770093
					STLIST=YES, REMOVE IF NO SELECTIVE TAPE FEATURE PRESENT	\$4770094
					IQAREA1=AREA	\$4770095
				322	FILE4 DTFPR DEVADDR=SYSLST,	\$4770096
					IQAREA1=PRNTAR	\$4770097
				343	MRMOD ADDRESS=DUAL,BUFFERS=100	\$4770098
				707	*	REMOVE (ADDRESS=DUAL) PARAMETER FROM THE ABOVE STATEMENT. \$4770099
				708	*	IF DUAL ADDRESSING ADAPTER FEATURE IS ABSENT, \$4770100
				709	PRMOD	\$4770101
					STLIST=YES, REMOVE IF NO SELECTIVE TAPE FEATURE	\$4770102
					RECFORM=FIXUNR	\$4770103

\$477 MCR2 SAMPLE PROBLEM						PAGE 3
LOC	OBJECT CODE	ADDR1	ADDR2	STMT	SOURCE STATEMENT	DOS CL3-C 03/12/69
				777	PRMOD RECFORM=FIXUNR	\$4770104
				844	MSGWRT DTFMN BLKSIZ=32,DEVADDR=SYSLOG,IQAREA1=MESSG,TYPFFLE=OUTPUT	\$4770105
				888	LTORG	\$4770106
000420				889	=C'\$\$\$BOPEN'	
000420	5B5BC20607C5D540			890	=C'\$\$\$BCLOSE'	
000428	5B5BC2C3D3D6E2C5			891	=A(FILE1)	
000430	00000188			892	=A(NEXT1)	
000434	00000C6E			893	=A(FILE3)	
000438	00000398			894	=A(CNTAD1)	
00043C	0000C470			895	=A(FILE2)	
000440	00000290			896	=A(NEXT2)	
000444	000000AC			897	=A(FILE4)	
000448	000003D0			898	=A(MSGWRT)	
00044C	00000400			899	DOCNT1 EQU 5	DOCUMENT COUNTER FOR FILE1 \$4770107
000005				900	DOCNT2 EQU 6	DOCUMENT COUNTER FOR FILE2 \$4770108
00000A				901	RETURN EQU 10	\$4770109
000450	4CC9D5E3C5D9E5C5			902	MESSG DC C' INTERVENTION REQUIRED ON FILE2 '	\$4770110
000470	01			903	CNTAD1 DC X'01'	SELECTIVE TAPE LIST TAPE INDICATOR \$4770111
000471	CC			904	CLOSID DC X'00'	CLOSED INDICATOR \$4770112
000472	00000CC000000000			905	BLANK DC 10X'00'	\$4770113
00047C	000000FA			906	TOTDOC DC F'250'	TOTAL NO. OF DOCUMENTS TO BE READ \$4770114
000480	4040404040404040			907	AREA DC 140C'	OUTPUT AREA FOR FILE3 \$4770115
00050C	4040404040404040			908	PRNTAR DC 140C'	OUTPUT AREA FOR FILE4 \$4770116
000548				909	AREA1 DS CL2600	INPUT AREA FOR FILE1 \$4770117
0005FC				910	AREA2 DS CL10600	INPUT AREA FOR FILE2 \$4770118
9C0000				911	END START	\$4770119

Figure 45. SYSLST Output for 1412/1419 Sample Problems (Part 5 of 7)

RELOCATION DICTIONARY				PAGE 1
PDS.ID	REL.ID	FLAGS	ADDRESS	
01	01	0C	00C00C	
01	01	0C	00C01C	
01	01	0C	00C014	
01	01	0C	00C018	
01	01	0C	000088	
01	01	0C	00C08C	
01	01	0C	0000F8	
01	01	0C	00C11C	
01	01	0C	00012C	
01	01	0C	00C13C	
01	01	0C	00019C	
01	02	18	00C199	
01	01	0C	00C1C0	
01	01	08	00C1F1	
01	01	08	0001E5	
01	01	0C	0001F8	
01	01	0C	00C1FC	
01	01	0C	00C1F0	
01	01	0C	0001FC	
01	01	0C	00C204	
01	01	0C	00C208	
01	01	08	00C20C	
01	01	08	0002E0	
01	01	0C	0002FC	
01	01	0C	0002F4	
01	01	0C	0002F8	
01	01	0C	000304	
01	01	0C	00030C	
01	01	0C	00C31C	
01	01	0C	00031C	
01	01	08	00C331	
01	01	08	000339	
01	01	08	000341	
01	01	08	00C349	

RELOCATION DICTIONARY				PAGE 2
PDS.ID	REL.ID	FLAGS	ADDRESS	
01	01	08	000351	
01	01	08	000359	
01	01	08	000361	
01	01	08	000369	
01	01	08	00C371	
01	01	08	000376	
01	01	08	00C381	
01	01	08	000389	
01	01	08	00C391	
01	01	0C	00C3A0	
01	03	18	0003A9	
01	01	0C	00C3BC	
01	01	08	00C3C1	
01	01	08	0003C9	
01	01	0C	0003D8	
01	04	18	0003F1	
01	01	0C	0003E8	
01	01	08	0003F9	
05	05	08	003D91	
05	05	08	003D99	
01	01	0C	000408	
01	08	08	000411	
01	01	08	000419	
01	01	0C	000430	
01	01	0C	000434	
01	01	0C	000438	
01	01	0C	00043C	
01	01	0C	000440	
01	01	0C	000444	
01	01	0C	000448	
01	01	0C	00044C	

Figure 45. SYSLST Output for 1412/1419 Sample Problems (Part 6 of 7)

Optical Readers

The 1285 sample problem is obtained by retrieving the sample problem for the 1287 journal tape mode of operation (Z.ORJT) and changing the cards with the sequence numbers 1058 and 1077 as follows. For both cards change the parameter DEVICE=1287T to DEVICE=1285. (Refer to listing containing the source statements for the sample test program for journal tape processing.)

The sample problem illustrating document processing for the 1287 Optical Reader (Z.ORDC) reads documents for data input into an input area, and then prints this data on SYSLST. Whenever the 1287 document hopper empties, press end-of-file or replenish the stack.

Any approved document type may be used because the reference mark and data field coordinates are entered at program execution time. However, the data field chosen to be read may not exceed six characters in length.

Figure 19 is a sample input document, and Figure 46 is the SYSLST output listing for document mode processing. The listing contains examples of keyed-in error corrections identified by comments.

The sample problem illustrating journal tape mode processing for the 1287 or 1285 Optical Readers reads undefined records from the 1287 or 1285 Optical Reader into a work area from two I/O areas, and then prints these records on SYSLST.

Any journal tape with a maximum record size of 38 characters is suitable for this sample problem.

Figure 20 is a portion of a sample input journal tape, and Figure 47 is the SYSLST output listing for journal tape processing.

The SYSLST output in Figures 46 and 47 contain:

- Job control cards
- External symbol dictionary
- Source program listing
- Relocation dictionary
- Linkage editor input diagnostics
- Linkage editor storage map
- List of fields read from documents (if sample problem for document processing was used).
or
Journal tape listing (If sample problem for journal tape processing was used.)
- EQJ Optical Reader
- // PAUSE END OF SAMPLE PROBLEM

```
// JOB OPTICAL READER SAMPLE PROBLEM
// ASSGN SYSC09,X'055'
// OPTION LINK,NXREF
// EXEC ASSEMBLY
```

```
EXTERNAL SYMBOL DICTIONARY

SYMBOL TYPE ID ADDR LENGTH LD ID

SAMPLE SD 01 C0C000 C00600
IJMFCZDZ ER 02
IJMFCZDZ SD 03 000600 000600
IJMFCZDZ LD 000600 03
IJDFFZZZ ER 04
IJDFFZZZ SD 05 C0C000 C0001A
```

SAMPLE TEST PROGRAM FOR DOCUMENT PROCESSING

LCC	OBJECT CODE	ADDR1	ADDR2	STMT	SOURCE STATEMENT	DCS CL3-0
				2	PRINT NOGEN	\$478C002
				3	START	\$478C003
000000	0530			4	BASERG BALR R,0	\$478C004
000002				5	USING +,R3	\$4780005
				6	OPEN ORDTF,PRTF	\$4780006
000016	9240 3472	00474		15	MVI DATAPRT,C' '	\$4780007
00001A	D277 3473 3472 00475 00474			16	MVC DATAPRT+1(120),DATAPRT	\$478C008
				17	PUT CNDTF	\$478C009
				22	GET CNDTF	\$478C010
				27	L R11,=F'4'	\$478C011
000038	5880 3242		00244	28	CNDP 2,4	\$478C012
00003C	0700			29	ALTER1 MVC BEGIN(4),CALBRTNS	\$4780013
00003E	D203 3456 33CE 00458 003D0			30	L R10,ALTER1+2	\$4780014
000044	58A0 303E		00040	31	A R10,=F'4'	\$478C015
000048	5AA0 3242		00244	32	ST R10,ALTER1+2	\$4780016
00004C	50A0 303E		00940	33	TP PFGIN,TARLE0-193	\$478C017
000050	DC03 3456 335C 00458 0035E			34	PACK TO(4),RFGIN(4)	\$478C018
000056	F233 345A 3456 0045C 00458			35	L R2,TO	\$478C019
00005C	5820 345A		0045C	36	SRL R2,4	\$478C020
000060	8820 0004		00004	37	SLL R2,16	\$478C021
000064	8920 0010		00010	38	ST R2,SAVE	\$478C022
000068	5020 3462		00464	39	CNDP 2,4	\$478C023
00006C	0700			40	ALTER2 MVC LNDMRK1(2),SAVE	\$478C024
00006E	D201 3226 3462 00228 00464			41	L R10,ALTER2+2	\$4780025
000074	58A0 306E		00070	42	A R10,CONST	\$4780026
000078	5AA0 345E		00460	43	ST R10,ALTER2+2	\$478C027
00007C	50A0 306F		00070	44	BCT R11,ALTER1	\$478C028
000080	4680 303C		0003E	46 *		\$478C030
				47 *		\$478C031
				48	READDCS READ ORDTF,OR,CCWADR	\$478C032
				54	WAITF ORDTF	\$478C033
0000A0	D205 3473 34E8 00475 004E0			59	MVC DATAPRT+1(6),INAREA	\$4780034
				60	CNTRL ORDTF,ESD,1	\$4780035
				66	PUT PRTF	\$4780036
				71	MVI INAREA,C' '	\$478C037
0000C0	9240 34EB	004E0		72	MVC INAREA+1(5),INAREA	\$478C038
0000C4	D204 34FC 34EB 004EE 004FD			73	MVI DATAPRT,C' '	\$4780039
0000CA	9240 3472	00474		74	MVC DATAPRT+1(120),DATAPRT	\$478C040
0000CE	D277 3473 3472 00475 00474			75	B READDCS	\$478C041
0000D4	47F0 3082		00084	76 *		\$4780042
				77 *		\$478C043
0000D8	90E1 3462		00464	79	COPRECT STM R14,R1,SAVE	\$4780045
0000DC	9101 3546	00548		81	DATAK TM ORDTF0,X'01'	\$478C047

Figure 46. SYSLST Output for Optical Reader Sample Problem -- Document Mode Processing (Part 1 of 5)

SAMPLE TEST PROGRAM FOR DOCUMENT PROCESSING									
LCC	OBJECT CODE	ADDR1	ADDR2	STMT	SOURCE	STATEMENT	DOS CL3-0		
000050	4780 30EC			82	RZ	WPLNGTH		NO, BR TO WRONG LNTH RFC TEST	\$4780048
0000E4	D22E 3486 3370	00488	00372	83	MVC	DATAPRP(47),DATAMSG		YES, MOVE DATA CK MSG	\$4780049
0000EA	47F0 3180		00182	84	B	RESCAN		BR TO RESCAN ROUTINE	\$4780050
0000EF	9104 3546	00548		86	WPLNGTH	TM	ORDTF80,X*04*	Q- WAS IT A WRONG LNTH RECCRD	\$4780052
0000F2	4780 30FE		00100	87	BZ	EQUIPC		NO, GO TEST EQUIP CHECK	\$4780053
0000F6	D22E 3496 3312	00488	00314	88	MVC	DATAPRP(47),WLENMSG		YES, MOVE WRONG LNTH REC MSG	\$4780054
0000FC	47F0 31FA		001FC	89	B	ENDIPT		TERMINATE PGM	\$4780055
000100	9108 3546	00548		91	EQUIPC	TM	ORDTF80,X*08*	Q- EQUIPCHECK	\$4780057
000104	4780 3110		00112	92	BZ	NONRECOV		NO, BR TO TEST NONRECOVERY	\$4780058
000108	D22E 3486 339F	00488	003A1	93	MVC	DATAPRP(47),EQUIPMMSG		YES, MOVE EQUIP CK MSG	\$4780059
00010E	47F0 31CE		00100	94	B	DISPLAY		BR TO DISPLAY ROUTINE	\$4780060
000112	9110 3546	00548		96	NONRECOV	TM	ORDTF80,X*10*	Q- NON RECOV	\$4780062
000116	4780 312E		00130	97	BZ	LATESS		NO, BR TO LATE SS TEST	\$4780063
00011A	D22E 3486 3256	00488	00258	98	MVC	DATAPRP(47),NONREC		YES, MOVE NONREC MSG	\$4780064
00012C	47F0 31FA		001FC	99	PUT	PRDTF		PRINT	\$4780065
				104	B	ENDIPT		TERMINATE PROGRAM	\$4780066
000130	9120 3546	00548		106	LATESS	TM	ORDTF80,X*20*	Q- LATE STACKER SELECT	\$4780068
000134	4780 314C		0014E	107	BZ	BADREFMK		NO, BR TO LOST REF MKR TEST	\$4780069
000138	D22E 3486 3285	00488	00287	108	MVC	DATAPRP(47),LATESTAK		YES, MOVE LATE STAK SEL MSG	\$4780070
00014A	47F0 31FA		001FC	109	PUT	PRDTF		PRINT	\$4780071
				114	B	ENDIPT		TERM--HARDWARE ERROR OCCURRED	\$4780072
00014E	9140 3546	00548		116	BADREFMK	TM	ORDTF80,X*40*	Q- BAD LD FRMT OF REF MARK	\$4780074
000152	4780 316A		0016C	117	BZ	ILLBIT		NO, ILLGL BIT WAS SET	\$4780075
000156	D22E 3486 3284	00488	00286	118	MVC	DATAPRP(47),RECALIBR		YES, MOVE RECALIBRATE MSG	\$4780076
000168	47F0 31FA		001FC	119	PUT	PRDTF		PRINT	\$4780077
				124	B	ENDIPT		TERM PGM	\$4780078
00016C	D22E 3486 32E3	00488	002E5	126	ILLBIT	MVC	DATAPRP(47),BADSENSE	MOVE MSG FOR ILL BIT SETTING	\$4780080
				127	PUT	PRDTF		PRINT	\$4780081
00017E	47F0 31FA		001FC	132	B	ENDIPT		TERM PGM	\$4780082
000182	4180 320E		00210	134	RESCAN	LA	R11,CCWADR	LOAD ADR OF COORD OF LNDMRK	\$4780084
000186	58A0 3516		00518	135	L	R10,ORDTF+32		LOAD ADR OF RDBKWRD CCM	\$4780085
00018A	58A0 3252		00254	136	S	R10,=F*8*		PCINT TO PRECEDING LD FORMAT	\$4780086
				138 *				REREAD TIME FIELD FIVE MORE TIMES AND FORCE ON-LINE CORRECTION	\$4780088
				139 *				IF NOT SUCCESSFUL	\$4780089

SAMPLE TEST PROGRAM FOR DOCUMENT PROCESSING									
LCC	OBJECT CODE	ADDR1	ADDR2	STMT	SOURCE	STATEMENT	DOS CL3-0		
				141		RESCN	ORDTF,(10),(11),5,F		\$4780091
0001AA	9108 3546	00548		150	TM	ORDTF80,X*08*		Q- EQUIPMENT CHECK	\$4780093
0001AE	4710 31CE		001D0	151	BO	DISPLAY		YES, GO TO DISPLAY FIELD	\$4780094
0001B2	9101 3546	00548		153	TM	ORDTF80,X*01*		NO, Q- DATA CHECK	\$4780096
0001B6	4780 318C		001BE	154	BZ	ANYERRS		NO, BR TO TEST OTHER ERRORS	\$4780097
0001BA	47F0 31CE		001D0	155	B	DISPLAY		YES, GO TO DISPLAY FIELD	\$4780098
0001BE	91F6 3546	00548		157	ANYERRS	TM	ORDTF80,X*F6*	Q- ANY OTHER ERRORS	\$4780100
0001C2	4780 31F2		001F4	158	BZ	RETRN		NO, GO TO RETRN TO PGM	\$4780101
0001C6	D22E 3486 3341	00488	00343	159	MVC	DATAPRP(47),RETRYERR		YES, MOVE RETRY ERR MSG	\$4780102
0001CC	47F0 31F2		001F4	160	B	RETRN		RETRN TO PGM	\$4780103
0001D0	4180 320E		00210	162	DISPLAY	LA	R11,CCWADR	LD ADR OF COORD OF LNDMRK	\$4780105
0001D4	58A0 3516		00518	163	L	R10,ORDTF+32		LD ADR OF RDBKWRD CCM	\$4780106
0001D8	58A0 3252		00254	164	S	R10,=F*8*		POINT TO PRECEDING LD FORMAT	\$4780107
				166		DSPLY	ORDTF,(10),(11)	DISPLAY FIELD FOR KYBRD CORR	\$4780109

Figure 46. SYSIST Output for Optical Reader Sample Problem -- Document Mode Processing (Part 2 of 5)

0001F4 98E1 3462	0C464	174	RETRN	LM	R14,R1,SAVE	RESTORE REGS	\$4780111
0001F8 07FE		175		BR	R14	RETURN FROM COREXIT TO NORM PROC	\$4780112
		177	ENDIPT	CLOSE	ORDTF,PRDTF	CLOSE ORDTF AND PRINT DTF	\$4780114
		186		EOJ		JOB EXIT	\$4780115
000210 5300022860C00004		19C	CCWADR	CCW	X'53',LNDMRK1,X'60',4	LANDMARK LOCATION	\$4780117
000218 5300022C60C00004		191		CCW	X'53',FILDMRK1,X'60',4	1ST FIELD LOCATION	\$4780118
000220 2C0004F220C00006		192		CCW	X'2C',INARFA+5,X'20',6	READ BKWRDS W/ DATA CK 6 BYTES	\$4780119
		194	*				\$478C121
000228		195	LNDMRK1	DS	F		\$478C122
00022C		196	FILDMRK1	DS	F	FIELD DEF-4TH BYTE FOR ON-LINE	\$4780123
		197	*				\$4780124
000230		199		LTORG			\$4780126
000230 585BC2D6D7C5D540		200			=C'\$\$BOPEN '		
000238 5859C2C3D3D6F2C5		201			=C'\$\$BCLCSE'		

SAMPLE TEST PROGRAM FOR DOCUMENT PROCESSING

LOC	OBJECT CODE	ADDR1	ADDR2	STMT	SOURCE	STATEMENT	DOS	CL3-0
000240	00000580			202		=A(CNDTF)		
000244	00000004			203		=F'4'		
000248	000004F8			204		=A(ORDTF)		
00024C	00000210			205		=A(CCWADR)		
000250	00000580			206		=A(PRDTF)		
000254	00000008			207		=F'8'		
000258	40D5D4D560D9C5C3			209	NONREC	DC	C* NON-RECOVERY OCCURRED.RELOAD AND RESTART 1287 '	\$4780128
000287	40D3C1E3C540E2E3			210	LATESTAK	DC	C* LATE STACKER SELECT. DDC IS SS IN REJECT PCKC '	\$478C129
000286	40C3D6E4D3C440D5			211	RECALIBR	DC	C* COULD NOT FIND LANDMARK- RECALIBRATE DOCUMENT '	\$4780130
0002E5	40E4D5D9C5C3D6C7			212	BADSENSE	DC	C* UNRECOGNIZABLE BIT WAS FOUND IN COREXIT TESTS '	\$478C131
000314	40E6D9D6D5C740D3			213	WLENMSG	DC	C* WRONG LENGTH RECORD WAS DETECTED. UNRECOV ERR.'	\$478C132
000343	40C1C6E3C5D940D9			214	RETRYERR	DC	C* AFTER RESCN-AN ERR OTHER THAN DATABK,EQUIP LOG'	\$4780133
000372	40C4C1E3C140C3C8			215	DATAMSG	DC	C* DATA CHECK	\$478C134
0003A1	40C5D8E4C9D7D4C5			216	EQUIPMMSG	DC	C* EQUIPMENT CHECK (INCOMPLETE READ)	\$4780135
				217	CALBRTNS	DC	C* ENTER 16 HEX DIGITS FOR REF MARK AND DATA FIELD COORDINATES, ALPHA- UPPER CASE.'	\$478C136
000300	C5D5E3C5D940F1F6			218	TABLE0	DC	X*FABFBCDFEFF'	\$4780137
00041F	FABFBCDFEFF			219	DS	CL41		\$478C138
000425				220	TABLE1	DC	C*0123456789'	\$4780139
00044E	F0F1F2F3F4F5F6F7			221	BEGIN	DS	F	\$478C140
000458				222	TO	DS	F	\$4780141
00045C				223	CONST	DC	X*00020000'	\$4780142
000460	00020000			223	CONST	DC	X*00020000'	\$4780143
000464				225	SAVE	DS	4F	\$4780145
000474				227	DATAPRT	DS	OCL121	\$4780147
000474				228	DS	CL20		\$4780148
000488				229	DATAPRP	DS	CL101	\$4780149
0004ED	404040404040			231	INAREA	DC	CL6' '	\$4780151
				233	***DTFS	AND MODULES		\$4780153
				234	ORDTF	DTFOR	BLKSIZE=6,	X\$4780154
							COREXIT=CORRECT,	X\$4780155
							DEVAADR=SYS009,	X\$4780156
							DEVICE=1287D,	X\$4780157
							CONTROL=YES,	X\$4780158
							EOFADDR=ENDIPT,	X\$4780159
							IOAREAL=INAREA	\$4780160
				281	ORMOD	CONTROL=YES,		X\$4780161
						DEVICE=1287D		\$4780162
				824	PRDTF	DTFPR	BLKSIZE=121,	X\$4780163
							DEVAADR=SYSLST,	X\$4780164
							IOAREAL=DATAPRT	\$4780165
				845	PRMOD			\$4780166
				907	CNDTF	DTFCN	DEVAADR=SYSLOG,	X\$4780167

Figure 46. SYSLST Output for Optical Reader Sample Problem -- Document Mode Processing (Part 3 of 5)

```

SAMPLE TEST PROGRAM FOR DOCUMENT PROCESSING

LOC OBJECT CODE ADDR1 ADDR2 STMT SOURCE STATEMENT          DOS CL3-0
00C548          940 ORDTF80 EQU IDAREAL=CALBRTNS,          X$478C168
000001          941 R1 EQU BLKSIZE=80                      $478C169
000002          942 R2 EQU ORDTF+80                      $478C17C
000003          943 R3 EQU 1                            $478C171
00000A          944 R10 EQU 2                            $478C172
00000B          945 R11 EQU 3                            $478C173
00000C          946 R12 EQU 10                           $478C174
00000E          947 R14 EQU 11                           $478C175
00000F          946 R12 EQU 12                           $478C176
00000E          947 R14 EQU 14                           $478C177

000000          949 END BASERG                          $478C179

RELOCATION DICTIONARY

DOS.ID REL.ID FLAGS ADDRESS
01 01 0C 00000C
01 01 0C 00001C
01 01 0C 000204
01 01 0C 000208
01 01 08 000211
01 01 08 000215
01 01 08 000221
01 01 0C 000240
01 01 0C 000248
01 01 0C 00024C
01 01 0C 000250
01 01 08 000501
01 01 08 000505
01 02 18 000509
01 01 08 000519
01 01 08 00051D
01 01 08 000521
01 01 08 000540
01 01 08 000551
01 01 08 000559
01 01 08 000561
01 01 0C 000568
01 01 0C 00056C
01 01 0C 000570
01 01 0C 000588
01 04 18 000591
01 01 0C 000598
01 01 08 0005A9
01 01 0C 0005B8
01 01 0E 0005C1
01 01 0E 0005C9

NO STATEMENTS FLAGGED IN THIS ASSEMBLY

// EXEC LNKEDT

```

Figure 46. SYSLST Output for Optical Reader Sample Problem -- Document Mode Processing (Part 4 of 5)

```
// JOB OPTICAL READER SAMPLE PROBLEM
// ASSGN SYS009,X*055*
// OPTION LINK,NCRREF
// EXEC ASSEMBLY
```

EXTERNAL SYMBOL DICTIONARY

SYMBOL	TYPE	ID	ADDR	LENGTH	LD	ID
	PC	01	000000	0007RC		
IJMCBZT	ER	02				
IJMCBZT	SD	03	0007C0	0005F0		
IJMCBZT	LD		0007C0		03	
IJDFCZIW	ER	04				
IJDFCZIW	SD	05	0000BC	000072		
IJDFCZIW	LD		0000BC		05	

SAMPLE TEST PROGRAM FOR JOURNAL TAPE PROCESSING

LCC	OBJECT	CORE	ADDR1	ADDR2	STMT	SOURCE STATEMENT	DOS CL3-0
					2	PRINT NOGEN	\$4781002
					3	START	\$4781003
000000	0560				4 BEGIN	BALR 6,0	\$4781004
000002					5	USING *,6	\$4781005
					6	OPEN INPUT,OUTPUT	OPEN OPTICAL READER AND PRINTER
000026	5B50	67AE		007B0	15 LOOP	GET INPUT,PRWORKA	GET RECORD FROM OPTICAL READER
00002A	4250	602D		0002F	21	S 5,=F*1'	SUBTRACT ONE FROM RECORD COUNT
00002E	D20D	64D4	654D	004D6	22	STC 5,#+5	PUT RECORD LENGTH IN MOVE
				0005F	23	MVC PRWORKA(14),ORWORKA	MOVE RECORD TO OUTPUT AREA
					24	PUT OUTPUT,PRWORKA	PUT RECORD TO PRINTER
000044	9240	64D4		004D6	30	MVI PRWORKA,C'	ZERO PRINTER
000048	D277	64D5	64D4	004D7	31	MVC PRWORKA+1(120),PRWORKA	IOAREA
00004E	47F0	6014		00016	32	B LOOP	
000052	90EF	60E2		000E4	33 CORP ECT	STM 14,15,SAVE	SAVE REGISTERS
000056	9110	65EE		005F0	34	TM INPUT+80,X*10'	TEST FOR NONRECOVERY
00005A	4710	60CE		000D0	35	BO ENDIPT	
00005E	9108	65EE		005F0	36	TM INPUT+80,X*08'	EQUIP CHECK TEST
000062	4710	6074		00076	37	BO CHECK1	IF YES, BRANCH TO CHECK1
000066	9101	65EE		005F0	38 REJECT	TM INPUT+80,X*01'	DATA CHECK TEST
00006A	4710	60A2		000A4	39	BO KEYBOARD	IF YES,BRANCH TO *KEYBOARD*
00006E	9102	65EE		005F0	40	TM INPUT+80,X*02'	KEYBOARD CORRECTION TEST
000072	4710	60C8		000CA	41	BO RESTORE	IF YES,BRANCH AND RESTORE REGS
000076	D21F	64FC	6573	004FE	42 CHECK1	MVC PRWORKA+40(32),MSG1	MOVE EQUIP MSG TO IO AREA
				00575	43	CNTRL INPUT,READKB	DSPLY INCOMPLETE READ
00008A	91FF	65EE		005F0	49	TM INPUT+80,X*FF'	TEST FOR ANY OTHER ERRORS
00008F	4780	60C8		000CA	50	BZ RESTORE	IF NO,BRANCH AND RESTORE REGS
					51	CNTRL INPUT,MARK	MARK THE ERROR LINE
0000A0	47F0	60C8		000CA	57	B RESTORE	BRANCH AND RESTORE REGISTERS
0000A4	9102	65EE		005F0	58 KEYBOARD	TM INPUT+80,X*02'	KEYBOARD CORRECTION TEST
0000A8	4710	6074		00076	59	BO CHECK1	IF YES,BRANCH AND RE-READ LINE
0000AC	D209	64FC	6593	004FE	60	MVC PRWORKA+40(10),MSG2	MOVE DATA CK MSG TO IO AREA
				00595	61	RDLNE INPUT	RE-READ CHARACTER
0000BE	91FF	65EE		005F0	66	TM INPUT+80,X*FF'	TEST FOR ANY OTHER ERRORS
0000C2	4780	60C8		000CA	67	BZ RESTORE	IF NO,BRANCH AND RESTORE REGS
0000C6	47F0	6074		00076	68	B CHECK1	BRANCH AND RE-READ LINE
0000CA	98EF	60E2		000F4	69 RESTORE	LM 14,15,SAVE	RESTORE REGISTERS
0000CE	07FE				70	RR 14	RETURN TO MAIN LINE
					71 ENDIPT	CLOSE INPUT,OUTPUT	CLOSE OPTICAL READER AND PRINTER
					80	EQJ	
0000E4	000000D0				83 SAVE	DC 1F*0'	\$4781040
0000EB	00000000				84	DC 1F*0'	\$4781041
0000EC	4040404040404040				85 FILINPT1	DC CL256'	\$4781042
0001EC	4040404040404040				86	DC CL124'	\$4781043
000268	4040404040404040				87 FILINPT2	DC CL256'	\$4781044
000368	4040404040404040				88	DC CL124'	\$4781045
0003E4	4040404040404040				89 FILOUPT1	DC CL121'	\$4781046
00045D	4040404040404040				90 FILOUPT2	DC CL121'	\$4781047
0004D6	4040404040404040				91 PRWORKA	DC CL121'	\$4781048
00054F	4040404040404040				92 ORWORKA	DC CL38'	\$4781049
000575	C5D8E4C9D704C5D5				93 MSG1	DC C'EQUIPMENT CHECK(INCOMPLETE READ)'	\$4781050
000595	C4C1E3C140C3C8C5				94 MSG2	DC C'DATA CHECK'	\$4781051

Figure 47. SYSLST Output for Optical Reader Sample Problem (Journal Tape Processing) (Part 1 of 4)

SAMPLE TEST PROGRAM FOR JOURNAL TAPE PROCESSING							DOS CL3-0
LOC	OBJECT CODE	ADDR1	ADDR2	STMT	SOURCE STATEMENT		
				95	***DTFS AND MODULES	\$4781C53	
				96	INPUT DTFOR BLKSIZE=380,	X\$4781054	
					BLKFAC=10,	X\$4781055	
					COREXIT=CORRECT,	X\$4781056	
					DEVADDR=SYS009,	X\$4781057	
					DEVICE=1287T,	X\$4781058	
					CONTROL=YES,	X\$4781059	
					EDFADDR=ENDIPT,	X\$4781060	
					IOAREA1=FILINPT1,	X\$4781061	
					IOAREA2=FILINPT2,	X\$4781062	
					RECFORM=UNDEF,	X\$4781063	
					RECSIZE=5,	X\$4781064	
					WORKA=YES	\$4781065	
				188	ORMOD RECFORM=UNDEF,	X\$4781066	
					BLKFAC=YES,	X\$4781067	
					WORKA=YES,	X\$4781068	
					CONTROL=YES,	X\$4781069	
					IOAREA2=YES,	X\$4781070	
					DEVICE=1287T	\$4781071	
				734	OUTPUT DTFPR 8LKSIZ=121,	X\$4781072	
					CONTROL=YES,	X\$4781073	
					DEVADDR=SYSLST,	X\$4781074	
					IOAREA1=FILOUPT1,	X\$4781075	
					IOAREA2=FILOUPT2,	X\$4781076	
					WORKA=YES	\$4781077	
				755	PRMOD CONTROL=YES,	X\$4781078	
					WORKA=YES,	X\$4781079	
					IOAREA2=YES	\$4781080	
000000				838	END BEGIN	\$4781081	
000798	5858C2D6D7C5D540			839	=C'\$\$BOPEN '		
0007A0	5858C2C3D3D6E2C5			840	=C'\$\$CLOSE'		
0007A8	000005A0			841	=A(INPUT)		
0007AC	0000054F			842	=A(ORWORKA)		
000780	00000001			843	=F'1'		
000794	00000768			844	=A(OUTPUT)		
000788	000004D6			845	=A(PRWORKA)		

RELOCATION DICTIONARY			
POS.ID	REL.ID	FLAGS	ADDRESS
01	01	0C	00000C
01	01	0C	000010
01	01	0C	000008
01	01	0C	00000C
01	01	08	0005A9
01	01	08	0005AD
01	02	18	000581
01	01	08	0005C1
01	01	08	0005C5
01	01	08	0005C9
01	01	08	0005F5
01	01	0C	0005F8
01	01	0C	0005FC
01	01	08	000609
01	01	0C	000610
01	01	0C	000614
01	01	0C	000618
01	01	08	000629
01	01	08	000631
01	01	08	000639
01	01	08	000641
01	01	08	000649
01	01	08	000651
01	01	08	000659
01	01	08	000661
01	01	08	000669
01	01	08	000671
01	01	08	000679
01	01	08	000681
01	01	08	000689
01	01	08	000691
01	01	08	000699
01	01	08	0006A1
01	01	08	0006A9
01	01	08	0006B1
01	01	08	0006B9
01	01	08	0006C1
01	01	08	0006E9
01	01	08	0006D1

Figure 47. SYSLST Output for Optical Reader Sample Problem (Journal Tape Processing) (Part 2 of 4)

```

C1      G1      C8      0006D9
01      01      08      0006E1
C1      01      08      0006E9
01      01      08      0006F1
C1      01      08      0006F9
01      01      08      000701
C1      01      08      000709
01      01      08      000711
01      01      08      000719
01      01      08      000721
01      01      08      000725
01      01      08      000731

```

RELOCATION DICTIONARY

POS-ID	REL-ID	FLAGS	ADDRESS
01	01	08	000739
01	01	08	000741
01	01	08	000749
01	01	08	000751
01	01	08	000759
01	01	08	000761
01	01	0C	000770
01	04	18	000779
01	01	0C	000780
01	01	C8	000791
01	01	0C	0007A8
01	01	0C	0007AC
01	01	0C	0007B4
01	01	0C	0007B8

NO STATEMENTS FLAGGED IN THIS ASSEMBLY

// EXEC LNKEOT

JOB OPTICAL DISK LINKAGE EDITOR DIAGNOSTIC OF INPUT

ACTION TAKEN	MAP
LIST	ENTRY

10/20/67	PHASE	XFR-AD	LOGCORE	HICORE	DSK-AD	ESD TYPE	LABEL	LOADED	REL-FR
	PHASE***	002800	002800	003E21	13 5 1	CSECT		002800	002800
						CSECT	IJMOCBTZ	002FC0	002800
						* ENTRY	IJMOZBTZ	002FC0	
						CSECT	IJDFCZIW	003580	002800
						* ENTRY	IJDFZ2IW	003580	

Figure 47. SYSLST Output for Optical Reader Sample Problem (Journal Tape Processing) (Part 3 of 4)

```
// EXEC
012 3456 789C
123 4567 890S
234 5678 901T
345 6789 012N
456 7890 123S
567 8901 234X
678 9012 345C
789 0123 456T
890 1234 567Z
901 2345 678-
012 3456 789C
123 4567 890S
234 5678 901T
345 6789 012N
456 7890 123S
567 8901 234X
678 9012 345C
789 0123 456T
890 1234 567Z
901 2345 678-
012 3456 789C
123 4567 890S
234 5678 901T
345 6789 012N
456 7890 123S
567 8901 234X
678 9012 345C
789 0123 456T
890 1234 567Z
901 2345 678-
012 3456 789C
123 4567 890S
234 5678 901T
345 6789 012N
456 7890 123S
567 8901 234X
678 9012 345C
789 0123 456T
890 1234 567Z
901 2345 678-
012 3456 789C
123 4567 890S
234 5678 901T
345 6789 012N
456 7890 123S
567 8901 234X
678 9012 345C
789 0123 456T
890 1234 567Z
901 2345 678-
012 3456 789C
```

EQJ OPTICAL

Figure 47. SYSLST Output for Optical Reader Sample Problem (Journal Tape Processing) (Part 4 of 4)

Emulator (1401/1460 and 1440)

Figure 48 shows the SYSLST output of the IBM Model 2025, and IBM Model 2030 emulator sample problems for the IBM Model 1440. The SYSLST output for IBM Model 1401/1460 sample problem is identical except for the sequence numbers 0088-0107 (see Figure 48). Figure 49 shows the SYSLST output of the IBM Model 2040 emulator sample problem for the IBM Model 1440. The SYSLST output for the IBM Model 1401/1460 is identical except for the sequence numbers 0029-0048 (see Figure 49). The sample problems list 20 records on the printer, and if a tape is available and assigned it will write them out on tape. Card numbers (cols. 73-76) 004, 006, and 051 must be removed from the deck and replaced by cards as instructed. For a complete description of the Emulator sample program and its output, refer to the Emulator Program manual listed in the Preface.

001	ABCDEFGHIJKLMN	OPQRSTUVWXYZ0123456789	1401/1440/1460	SAMPLE PROGRAM	0088
002	ABCDEFGHIJKLMN	OPQRSTUVWXYZ0123456789	1401/1440/1460	SAMPLE PROGRAM	0089
003	ABCDEFGHIJKLMN	OPQRSTUVWXYZ0123456789	1401/1440/1460	SAMPLE PROGRAM	0090
004	ABCDEFGHIJKLMN	OPQRSTUVWXYZ0123456789	1401/1440/1460	SAMPLE PROGRAM	0091
005	ABCDEFGHIJKLMN	OPQRSTUVWXYZ0123456789	1401/1440/1460	SAMPLE PROGRAM	0092
006	ABCDEFGHIJKLMN	OPQRSTUVWXYZ0123456789	1401/1440/1460	SAMPLE PROGRAM	0093
007	ABCDEFGHIJKLMN	OPQRSTUVWXYZ0123456789	1401/1440/1460	SAMPLE PROGRAM	0094
008	ABCDEFGHIJKLMN	OPQRSTUVWXYZ0123456789	1401/1440/1460	SAMPLE PROGRAM	0095
009	ABCDEFGHIJKLMN	OPQRSTUVWXYZ0123456789	1401/1440/1460	SAMPLE PROGRAM	0096
010	ABCDEFGHIJKLMN	OPQRSTUVWXYZ0123456789	1401/1440/1460	SAMPLE PROGRAM	0097
011	ABCDEFGHIJKLMN	OPQRSTUVWXYZ0123456789	1401/1440/1460	SAMPLE PROGRAM	0098
012	ABCDEFGHIJKLMN	OPQRSTUVWXYZ0123456789	1401/1440/1460	SAMPLE PROGRAM	0099
013	ABCDEFGHIJKLMN	OPQRSTUVWXYZ0123456789	1401/1440/1460	SAMPLE PROGRAM	0100
014	ABCDEFGHIJKLMN	OPQRSTUVWXYZ0123456789	1401/1440/1460	SAMPLE PROGRAM	0101
015	ABCDEFGHIJKLMN	OPQRSTUVWXYZ0123456789	1401/1440/1460	SAMPLE PROGRAM	0102
016	ABCDEFGHIJKLMN	OPQRSTUVWXYZ0123456789	1401/1440/1460	SAMPLE PROGRAM	0103
017	ABCDEFGHIJKLMN	OPQRSTUVWXYZ0123456789	1401/1440/1460	SAMPLE PROGRAM	0104
018	ABCDEFGHIJKLMN	OPQRSTUVWXYZ0123456789	1401/1440/1460	SAMPLE PROGRAM	0105
019	ABCDEFGHIJKLMN	OPQRSTUVWXYZ0123456789	1401/1440/1460	SAMPLE PROGRAM	0106
020	ABCDEFGHIJKLMN	OPQRSTUVWXYZ0123456789	1401/1440/1460	SAMPLE PROGRAM	0107

Figure 48. SYSLST Output for Emulator Sample Problem (IBM Model 2030)

001	ABCDEFGHIJKLMN	OPQRSTUVWXYZ0123456789	1401/1440/1460	SAMPLE PROGRAM	0029
002	ABCDEFGHIJKLMN	OPQRSTUVWXYZ0123456789	1401/1440/1460	SAMPLE PROGRAM	0030
003	ABCDEFGHIJKLMN	OPQRSTUVWXYZ0123456789	1401/1440/1460	SAMPLE PROGRAM	0031
004	ABCDEFGHIJKLMN	OPQRSTUVWXYZ0123456789	1401/1440/1460	SAMPLE PROGRAM	0032
005	ABCDEFGHIJKLMN	OPQRSTUVWXYZ0123456789	1401/1440/1460	SAMPLE PROGRAM	0033
006	ABCDEFGHIJKLMN	OPQRSTUVWXYZ0123456789	1401/1440/1460	SAMPLE PROGRAM	0034
007	ABCDEFGHIJKLMN	OPQRSTUVWXYZ0123456789	1401/1440/1460	SAMPLE PROGRAM	0035
008	ABCDEFGHIJKLMN	OPQRSTUVWXYZ0123456789	1401/1440/1460	SAMPLE PROGRAM	0036
009	ABCDEFGHIJKLMN	OPQRSTUVWXYZ0123456789	1401/1440/1460	SAMPLE PROGRAM	0037
010	ABCDEFGHIJKLMN	OPQRSTUVWXYZ0123456789	1401/1440/1460	SAMPLE PROGRAM	0038
011	ABCDEFGHIJKLMN	OPQRSTUVWXYZ0123456789	1401/1440/1460	SAMPLE PROGRAM	0039
012	ABCDEFGHIJKLMN	OPQRSTUVWXYZ0123456789	1401/1440/1460	SAMPLE PROGRAM	0040
013	ABCDEFGHIJKLMN	OPQRSTUVWXYZ0123456789	1401/1440/1460	SAMPLE PROGRAM	0041
014	ABCDEFGHIJKLMN	OPQRSTUVWXYZ0123456789	1401/1440/1460	SAMPLE PROGRAM	0042
015	ABCDEFGHIJKLMN	OPQRSTUVWXYZ0123456789	1401/1440/1460	SAMPLE PROGRAM	0043
016	ABCDEFGHIJKLMN	OPQRSTUVWXYZ0123456789	1401/1440/1460	SAMPLE PROGRAM	0044
017	ABCDEFGHIJKLMN	OPQRSTUVWXYZ0123456789	1401/1440/1460	SAMPLE PROGRAM	0045
018	ABCDEFGHIJKLMN	OPQRSTUVWXYZ0123456789	1401/1440/1460	SAMPLE PROGRAM	0046
019	ABCDEFGHIJKLMN	OPQRSTUVWXYZ0123456789	1401/1440/1460	SAMPLE PROGRAM	0047
020	ABCDEFGHIJKLMN	OPQRSTUVWXYZ0123456789	1401/1440/1460	SAMPLE PROGRAM	0048

● Figure 49. SYSLST Output for Emulator Sample Problem (IBM Model 2040)

Appendix A. IPL Control and ASSGN Statements for System Generation

The formats for the ADD and SET statements are given in this section. These statements are used at IPL time. If standard physical unit description and assignments are made when assembling the supervisor and these correspond to the configuration used when the system was generated, no ADD or ASSGN statements are required during subsequent IPL procedures. The SET statement is always required.

ADD (ADD A DEVICE)

Operation	Operand
ADD	X'cuu' [(k)], devicetype[, X'ss']

The entries in the operand field represent the following:

X'cuu'

Channel and unit numbers.

(k)

Specify S if the device is to be switchable (the device is physically attached to two adjacent channels). The designated channel is the lower of the two channels. If the device is not switchable, K=0-254. This indicates the priority on the channel of the device, with 0 the highest priority.

devicetype

Actual device (2311, 2400T9, 1443, etc). See Figure 5.

X'ss'

Device specifications: If absent for 7- or 9-track tapes, X'90' or X'C0' is assumed. (See ASSGN statement for the proper entries.)

The device specifications for an IBM 2702 Transmission Control Unit are:

X'00' for SAD0 X'02' for SAD2
X'01' for SAD1 X'03' for SAD3

The device specification for a 1053 attached to a 2848 is: X'01'.

If the device type is omitted for a 2702 Transmission Control Unit, X'00' is assumed.

SET (SET THE DATE)

Operation	Operand
SET	DATE= mm/dd/yy [,CLOCK=hh/mm/ss] dd/mm/yy

Select one of the formats for the date. Replace mm with the month, dd with the day, yy with the year. The format selected must concur with the option selected at system generation. Systems delivered by IBM use the mm/dd/yy format.

If the Timer Feature was specified during supervisor generation, include CLOCK=hh/mm/ss where hh is hours, mm is minutes, and ss is seconds.

ASSGN (ASSIGN LOGICAL NAME)

The ASSGN command assigns a logical input/output unit to a physical device.

Operation	Operand
ASSGN	SYSnnn,X'cuu' ,X'ss' ,ALT

The entries in the operand field represent the following:

SYSnnn

The symbolic unit name. It may be one of the following:

- SYSRDR SYSLST SYSIN
- SYSIPT SYSLOG SYSOUT
- SYSPCH SYSLNK SYS000-SYS221

X'cuu'

Indicates the hexadecimal channel (c) and unit (uu) number. C=0 for the multiplexor channel. C=1-6 for selector channels 1-6.

X'ss'

Device specifications for 7- and 9-track tape are:

ss	Bytes Per Inch	Parity	Trans- late Feature	Convert Feature
10	200	odd	off	on
20	200	even	off	off
28	200	even	on	off
30	200	odd	off	off
38	200	odd	on	off
50	556	odd	off	on
60	556	even	off	off
68	556	even	on	off
70	556	odd	off	off
78	556	odd	on	off
90	800	odd	off	on
A0	800	even	off	off
A8	800	even	on	off
B0	800	odd	off	off
B8	800	odd	on	off
C0	800	9-track single density		
C0	1600	9-track dual density		
C8	800	9-track dual density		
C0	1600	9-track single density		

ALT

Alternate tape unit is to be used when the capacity of the original assignment is reached.

Appendix B. IOCS Modules for COBOL, RPG and PL/I

This appendix lists the preassembled IOCS modules used by COBOL, PL/I, and RPG object programs. No IOCS modules are required by FORTRAN. For assembler language programs, the user can preassemble IOCS modules as described in the Supervisor and Input/Output Macros publication referenced on the cover of this publication. The following preassembled modules for COBOL, PL/I, and RPG can be used by any other program whenever applicable. Each module name begins with a 3-character prefix and consists of a 5-character field corresponding to the option permitted in generation of the module.

CDMOD name = IJCabdcde

a = F if RECFORM=FIXUNB (always for INPUT CMBND files)
= V if RECFORM=VARUNB
= U if RECFORM=UNDEF

b = A if CTLCHR=ASA is specified (not specified in CMBND)
= Y if CTLCHR=YES is specified
= C if CONTROL=YES is specified
= Z if neither CTLCHR nor CONTROL is specified

c = I if TYPEFLE=INPUT
= O if TYPEFLE=OUTPUT
= C if TYPEFLE=CMBND

d = Z if neither WORKA nor IOAREA2 is specified
= W if WORKA=YES is specified
= I if IOAREA2=YES
= B if both WORKA and IOAREA2 are specified

For CMBND files:

If WORKA=YES is specified, d = W
If WORKA=YES is not specified, d = Z

e = 0 if DEVICE=2540
= 1 if DEVICE=1442
= 2 if DEVICE=2520
= 3 if DEVICE=2501
= 4 if DEVICE=2540 and CRDERR is specified
= 5 if DEVICE=2520 and CRDERR is specified

<u>COBOL</u>	<u>RPG</u>	<u>PL/I</u>
IJCFZIZ0*	IJCFCCZ0	IJCFAOI1*
IJCFZ IZ1*	IJCFCCZ1	IJCFAOI2*
IJCFZIZ2*	IJCFCCZ2	IJCFAOI4*
IJCFZ IZ3**	IJCFCIZ0	IJCFAOZ1*
IJCFZ II0**	IJCFCIZ1	IJCFAOZ2*
IJCFZ III1**	IJCFCIZ2	IJCFAOZ4*
IJCFZ II2**	IJCFYOI0	IJCFYOI1***
IJCFZII3**	IJCFYOI1***	IJCFYOI2***
IJCFAOI0	IJCFYOI2***	IJCFYOI4
IJCFAOI1*	IJCFYOZ0	IJCFYOZ1***
IJCFAOI2*	IJCFYOZ1***	IJCFYOZ2***
IJCFAOI4*	IJCFYOZ2***	IJCFYOZ4
IJCFAOI5	IJCFZII0**	IJCFZII0**
IJCFAOZ0	IJCFZII1**	IJCFZII1**
IJCFAOZ1*	IJCFZII2**	IJCFZII2**
IJCFAOZ2*	IJCFZII3**	IJCFZII3**
IJCFAOZ4*	IJCFZIZ3**	IJCFZIZ0*
IJCFAOZ5		IJCFZIZ1*
IJCFZOI1*		IJCFZIZ2*
IJCFZOI2*		IJCFZIZ3**
IJCFZOI4*		IJCFZOI1*
IJCFZOI5		IJCFZOI2*
IJCFZOZ1*		IJCFZOI4*
IJCFZOZ2*		IJCFZOZ1*
IJCFZOZ4*		IJCFZOZ2*
IJCFZOZ5		IJCFZOZ4*

*common to COBOL and PL/I
**common to COBOL, RPG, and PL/I
***common to RPG and PL/I

PRMOD name = IJDabcde

a = F if RECFORM=FIXUNB
= V if RECFORM=VARUNB
= U if RECFORM=UNDEF

b = A if CTLCHR=ASA is specified
= Y if CTLCHR=YES is specified
= C if CONTROL=YES is specified
= Z if neither CTLCHR nor CONTROL is specified

c = P if PRINTOV=YES is specified
= Z if PRINTOV=YES is not specified

d = I if IOAREA2=YES is specified
= Z if IOAREA2=YES is not specified

e = W if WORKA=YES is specified
= Z if WORKA=YES is not specified

<u>COBOL</u>	<u>RPG</u>	<u>PL/I</u>
IJDFAPIZ	IJDFYPZW	IJDFAZIZ
IJDFAPZZ	IJDFYPZZ	IJDFAZZZ
IJDFZPIZ*		IJDFYZZZ
IJDFZPZZ*		IJDFYZIZ
		IJDFZPZZ*
		IJDFZPIZ*

*common to COBOL and PL/I

MTMOD name = IJFabcde

a = F if RECFORM=FIXUNB (or FIXBLK)
 = V if RECFORM=VARUNB (or VARBLK)
 = U if RECFORM=UNDEF

b = B if READ=BACK is specified
 = Z if READ=FORWARD or is not specified

c = C if CKPTREC=YES is specified
 = Z if CKPTREC=YES is not specified

d = W if WORKA=YES is specified
 = Z if WORKA=YES is not specified

e = Z always

<u>COBOL</u>	<u>RPG</u>	<u>PL/I</u>
IJFUBCZZ	IJFVZCWZ	IJFFBZZZ
IJFVBCZZ	IJFFZCZZ	IJFFZZZZ
IJFFBCZZ		IJFVZZZZ
IJFVBCWZ		IJFUBZZZ
		IJFUZZZZ

SDMODxx name = IJGabcde

a = F if records are fixed unblocked or fixed blocked
 = V if records are variable unblocked or variable blocked
 = U if records are undefined

b = U if file is an update file
 = I if file is an input file
 = O if file is an output file

c = E if ERROPT=YES is specified
 = Z if ERROPT=YES is not specified

d = T if TRUNCS=YES is specified
 = Z if TRUNCS=YES is not specified

e = C if CONTROL=YES is specified
 = Z if CONTROL=YES is not specified

<u>COBOL</u>	<u>RPG</u>	<u>PL/I</u>
IJGFIETZ*	IJGFIZZZ**	IJGFIETZ*
IJGFIZZZ**	IJGFOZZZ**	IJGFIEZZ
IJGFOZZZ**	IJGFUZZZ**	IJGZIEZZ
IJGFUZZZ**	IJGVIZZZ**	IJGFOEZZ
IJGUIEZZ*	IJGVOZZZ**	IJGFUEZZ
IJGUIZZZ	IJGVUZZZ**	IJGUIEZZ*
IJGUOZZZ		IJGUOEZZ
IJGUZZZ		IJGUUEZZ
IJGVIEZZ*		IJGVIEZZ*
IJGVI ZZZ**		IJGVOEZZ
IJGVOZZZ**		IJGVUEZZ
IJGVUZZZ**		

*common to COBOL and PL/I
**common to COBOL and RPG

ISMOD name = IJHabcde

a = A if RECFORM=BOTH and IOROUT specifies ADD or ADDRTR
= B if RECFORM=FIXBLK and IOROUT specifies ADD or ADDRTR
= U if RECFORM=FIXUNB and IOROUT specifies ADD or ADDRTR
= Z if IOROUT specifies LOAD or RETRVE

b = L if IOROUT=LOAD
= I if IOROUT=ADD
= R if IOROUT=RETRVE
= A if IOROUT=ADDRTR

c = R if TYPEFLE=RANDOM is specified
= S if TYPEFLE=SEQNTL is specified
= B if TYPEFLE=RANSEQ is specified
= Z if TYPEFLE is not specified

d = C if CORINDX=YES is specified
= Z if CORINDX is not specified

e = P if CORDATA=YES is specified
= Z if CORDATA is not specified

COBOLRPGPL/I

IJHAABZZ
IJHAARCP***
IJHAARCZ***
IJHAARZP***
IJHAARZZ***
IJHAASZZ
IJHAI ZZZ
IJHBABZZ
IJHBARCP***
IJHBARCZ***
IJHBARZP***
IJHBARZZ***
IJHBASZZ
IJHBI ZZZ
IJHUABZZ
IJHUARCP***
IJHUARCZ***
IJHUARZP***
IJHUARZZ***
IJHUASZZ
IJHUI ZZZ
IJHZLZZZ**
IJHZRBZZ*
IJHZRRCZ***
IJHZRRZZ**
IJHZRSZZ**

IJHZLZZZ**
IJHZRBZZ**
IJHZRRZZ**
IJHZRSZZ**

IJHAARCP***
IJHAARCZ***
IJHAARZP***
IJHAARZZ***
IJHBARCP***
IJHBARCZ***
IJHBARZP***
IJHBARZZ***
IJHUARCP***
IJHUARCZ***
IJHUARZP***
IJHUARZZ***
IJHZLZZZ**
IJHZRRCZ***
IJHZRRZZ**
IJHZRSZZ**

*common to COBOL and RPG
**common to COBOL, RPG, and PL/I
***common to COBOL and PL/I

DAMOD name = IJIabcde

a = F if RECFORM=FIXUNB
= B if RECFORM=UNDEF (handles both UNDEF and FIXUNB)

b = A if AFTER=YES is specified
= Z if AFTER is not specified

c = I if IDLOC is specified
= Z if IDLOC is not specified

d = Z always

e = Z always

<u>COBOL</u>	<u>RPG</u>	<u>PL/I</u>
IJIEAIZZ	IJIBZZZZ**	IJIFAZZZ*
IJIBAZZZ		IJIFZZZZ*
IJIEZ IZZ		
IJIBZZZZ**		
IJIEAIZZ		
IJIFAZZZ*		
IJIFZIZZ		
IJIFZZZZ*		

*common to COBOL and PL/I
**common to COBOL and RPG

Name list for MTMOD Work File Type Modules (TYPEFLE=WORK).

MTMOD name = IJFWabcd

a = E if ERROPT=YES is specified
= Z if ERROPT is not specified

b = N if NOTEPNT=YES is specified
= Z if NOTEPNT=YES is not specified
= S if NOTEPNT=PCINTS is specified

c = Z always

d = Z always

System I/O Modules

For MTMOD:

IJFWEZZZ
IJFWZNZZ
IJFWZZZZ

Name List for SDMOD Work File Type Modules

SDMODW name = IJGWabcd

a = E if ERROPT=YES
= Z if ERROPT is not specified.

b = R if NOTEPNT=POINTRW is specified
= N if NOTEPNT=YES is specified
= Z if NOTEPNT is not specified

c = Z always

d = Z always

System I/O Modules

IJGWEZZU
IJGWEZZZ
IJGWZNZZ
IJGWZRZZ

DIMOD name = IJJabcde

a = F for fixed unblocked record format

b = C for ASA and System/360 control character support for printers and punches

c = B if an output file is specified (processes both input and output)
= I if an input file is specified

d = I if IOAREA2=YES is specified
= Z if IOAREA2=YES is not specified

e = D for DOS DIMOD

COBOL

RPG

PL/I

IJJFCBID

IJJFCBZD

IJJFCIID

IJJFCIZD

Appendix C. IBM System Components Identification

Core Image Phases

All program phase names in the core image library are composed of two four-character parts. The first four characters uniquely identify the program. The next four characters identify the phase of the program. The first phase of a program to be executed from the core image library (cataloged on SYSRES) must be identical to the name specified in the // EXEC control statement. For RPG, the first 4 characters of the phase names are RPG1, although the processor is invoked by

// EXEC RPG.

All IBM-supplied phase names begin with an alphabetic character (A-Z). Three classes of programs are exceptions:

1. Transient routines. Type A transient routines (device error routines) have the prefix \$\$A. (\$ is an alphabetic character in System/360.) Type B transient routines (OPEN, CLOSE, CHKPT, etc) have the prefix \$\$B.

Device Error Routines and OPEN/CLOSE Phases for Disk Operating System

\$\$ANERAE	Message Writer
\$\$ANERRA	Error recovery monitor
\$\$ANERRB	Error recovery monitor
\$\$ANERRC	Error recovery monitor
\$\$ANERRD	Tape-error recovery
\$\$ANERRE	Tape-error recovery
\$\$ANERRF	Tape-error recovery
\$\$ANERRG	Data cell (2321)-error recovery
\$\$ANERRH	Data cell error recovery
\$\$ANERRI	Data cell (2321)-error recovery
\$\$ANERRJ	Data cell (2321)-error recovery
\$\$ANERRK	Data cell (2321)-error recovery
\$\$ANERRL	Tape-error recovery
\$\$ANERRM	Message writer
\$\$ANERRN	Message writer
\$\$ANERRO	Attention routine
\$\$ANERRP	Message writer
\$\$ANERRQ	Message writer
\$\$ANERRR	Message writer
\$\$ANERRS	System control
\$\$ANERRT	1412/1419 error recovery
\$\$ANERRU	Unit record error recovery
\$\$ANERRV	Unit record error recovery
\$\$ANERRW	1419D error recovery
\$\$ANERRX	Paper tape error recovery
\$\$ANERRY	Physical attention routine
\$\$ANERRZ	Physical attention routine
\$\$ANERRO	Physical attention routine
\$\$ANERR1	Modify communication region
\$\$ANERR6	2495 Tape Cartridge Reader Error Recovery Phase
\$\$ANERR7	2495 Tape Cartridge Reader
\$\$ANERR8	2495 Tape Cartridge Reader
\$\$ANERR9	Optical character reader-error recovery procedure
\$\$BATST1	Autotest (2311 only)
\$\$BATST3	Autotest (2311 only)
\$\$BATTNA	Supervisor-program terminator

\$\$BATTNB	Supervisor-program terminator
\$\$BATTNC	Supervisor-initiator
\$\$BATTND	Supervisor-nonresident attention routine
\$\$BATTNE	Supervisor-nonresident attention routine
\$\$BATTNF	Supervisor-nonresident attention routine
\$\$BATTNG	Supervisor-nonresident attention routine
\$\$BATTNH	Supervisor-nonresident attention routine
\$\$BATTNI	Supervisor-foreground initiator
\$\$BATTNJ	Supervisor-foreground initiator
\$\$BATTNK	Supervisor-foreground initiator
\$\$BATTNL	Supervisor-foreground initiator
\$\$BATTNM	Supervisor-foreground initiator
\$\$BATTNN	Supervisor-nonresident attention
\$\$BATTNO	Supervisor-nonresident attention
\$\$BATTNP	Supervisor-nonresident attention
\$\$BCBLIS	COBOL
\$\$BCBLOP	COBOL
\$\$BCBODA	COBOL
\$\$BCBUSR	COBOL
\$\$BCBUSW	COBOL
\$\$BCCPT1	DTFCP tape open
\$\$BCEOV1	Monitor-EOV/EOF
\$\$BCHKPD	Disk-checkpoint
\$\$BCHKPE	Disk-checkpoint
\$\$BCHKPF	Disk-checkpoint
\$\$BCHKPT	Tape-checkpoint
\$\$BCHKP2	Tape-checkpoint
\$\$BCISOA	ISFMS - CLOSE
\$\$BCLOSE	Close monitor
\$\$BCLOSP	Punch file close
\$\$BCLOS2	Close
\$\$BCMR01	Magnetic Character Reader-close
\$\$BCMT01	Tape EOF/EOV input-forward
\$\$BCMT02	Tape CLOSE-alternate switching
\$\$BCMT03	Tape CLOSE input-backward
\$\$BCMT04	Tape EOV output-forward
\$\$BCMT05	Tape CLOSE
\$\$BCMT06	Tape CLOSE-workfiles
\$\$BCMT07	Tape-alternate switching
\$\$BCTC01	CLOSE routine--BTAM
\$\$BDRSTR	Disk restart phase
\$\$BDUMP	Supervisor-program terminator
\$\$BDUMPB	Supervisor-program terminator
\$\$BDUMPD	Supervisor-program terminator
\$\$BENDFF	ISFMS-ENDFL (Load phase 2)
\$\$BENDFL	ISFMS-ENDFL (Load phase 1)
\$\$BEOJ	Supervisor-program terminator
\$\$BEOJ1	Supervisor-program terminator
\$\$BEOJ2	Supervisor-program terminator
\$\$BEOJ3	Supervisor-program terminator
\$\$BEOJ4	Supervisor-program terminator
\$\$BEOJ5	Supervisor-program terminator
\$\$BERRTN	CPMOD-error recovery
\$\$BETPRT	Error threshold message
\$\$BHDRCK	Terminal test request validation and comparison
\$\$BILSVC	Supervisor-program terminator
\$\$BINDEX	Cylinder index in core (ISFMS)
\$\$BJCOPT	Job Control-OPEN TAPE routine
\$\$BLEPRT	Line error print routine
\$\$BLISTV	List VTOC
\$\$BLOPEN	OPEN routine
\$\$BLSTIO	System control
\$\$BMMR20	Magnetic Character Reader Message
\$\$BMSGWR	Tape open/close
\$\$BMU100	MPS utility

\$\$BMU200	MPS utility
\$\$BMU300	MPS utility
\$\$BCOP12	DTFCP-OPEN
\$\$BOCPM1	Message writer
\$\$BOCPM2	Message writer
\$\$BOCPT1	Open DTFCP or DTFDI
\$\$BOCPT2	Open-Output tape
\$\$BOCPT3	Open-Output tape
\$\$BOCP01	Open-Disk labels
\$\$BOCP02	Open-Tape
\$\$BOCP11	OPEN - IBM Processor Programs
\$\$BOCP12	OPEN - IBM Processor Programs
\$\$BODACL	Close Routine-DA
\$\$BODAI1	Open input-DA
\$\$BODAIN	Direct access input-OPEN (Input)
\$\$BODAO1	Direct access-OPEN OUTPUT Phase 1
\$\$BODAO2	Direct access-OPEN OUTPUT Phase 2
\$\$BODAO3	Direct access OPEN-OUTPUT Phase 3
\$\$BODAO4	Direct access OPEN-OUTPUT Phase 4
\$\$BODAU1	Direct access-OPEN (user)
\$\$BODQUE	Dequeue JIB's
\$\$BODSPV	Disk VTOC display routine
\$\$BODSPW	Disk VTOC display routine
\$\$BOFLPT	DASD file protect
\$\$BOIS01	ISFMS - OPEN I/O Phase 1
\$\$BOIS02	ISFMS - OPEN I/O Phase 2
\$\$BOIS03	ISFMS - OPEN I/O Phase 3
\$\$BOIS04	ISFMS - OPEN I/O Phase 4
\$\$BOIS05	ISFMS - OPEN I/O Phase 5
\$\$BOIS06	ISFMS - OPEN I/O Phase 6
\$\$BOIS07	ISFMS - OPEN I/O Phase 7
\$\$BOIS08	ISFMS - OPEN I/O Phase 8
\$\$BOIS09	Index sequential independent overflow area integrity
\$\$BOIS10	ISFMS - OPEN
\$\$BOMR01	Magnetic Character Reader-open
\$\$BOMSG1	Message non-abort types
\$\$BOMSG2	Message writer - abort types
\$\$BOMSG3	Message writer
\$\$BOMSG4	Message writer
\$\$BOMSG5	Message writer
\$\$BOMSG6	Message writer
\$\$BOMT0M	Tape open message
\$\$BOMT0W	Tape open message
\$\$BOMT01	Tape OPEN input-forward-standard labels
\$\$BOMT02	Tape OPEN input-backward-standard labels
\$\$BOMT03	Tape OPEN output forward-standard label
\$\$BOMT04	Tape OPEN output-standard labels
\$\$BCMT05	Tape OPEN I/O-forward/backward Non-standard/unlabeled
\$\$BOMT06	Tape OPEN workfiles
\$\$BOOR01	Optical character reader-OPEN
\$\$BOPEN	Open monitor
\$\$BOPENR	OPENC
\$\$BOPENR	Relocation Phase 1
\$\$BOPEN2	Open monitor
\$\$BOPIGN	COBOL-open
\$\$BOPNLB	Locates source statement library. Directory also locates source statement library (for Assembler and COBOL)
\$\$BOPNR2	Relocation Phase 2
\$\$BORTV1	ISFMS Open
\$\$BORTV2	ISFMS Open
\$\$BOSDC1	Sequential disk I/O - CLOSE
\$\$BOSDC2	Sequential disk-close
\$\$BOSDI1	Sequential disk input - OPEN
\$\$BOSDI2	Sequential disk input - OPEN
\$\$BOSDI3	Sequential disk input - OPEN

\$\$BOSDO1	Sequential disk output Phase 1 - OPEN
\$\$BOSDO2	Sequential disk output Phase 2 - OPEN
\$\$BOSDO3	Sequential disk OPEN output Phase 3
\$\$BOSDO4	Sequential disk output Phase 4 - OPEN
\$\$BOSDO5	Sequential disk output Phase 5 - OPEN
\$\$BOSDO6	Sequential disk open - Phase 6
\$\$BOSDO7	Sequential disk output - OPEN
\$\$BOSDO8	Sequential disk output - OPEN
\$\$BOSDW1	Sequential disk workfiles Phase 1 - OPEN
\$\$BOSDW2	Sequential disk workfiles Phase 2 - OPEN
\$\$BOSDW3	Sequential workfile Phase 3 - OPEN
\$\$BOSD00	Sequential disk OPEN - output Phase 0
\$\$BOSD01	Sequential disk OPEN - output Phase 1
\$\$BOSIGN	COBOL-Open
\$\$BOTC01	OPEN routine
\$\$BOUR01	Unit record-OPEN routine
\$\$BOVDMP	Disk VTOC dump
\$\$BPCHK	Supervisor - program terminator
\$\$BDUMP	Supervisor - program terminator
\$\$BPLOSE	PL/I OPEN/CLOSE
\$\$BPSW	Supervisor - program terminator
\$\$BRMSG1	Message writer CHKPT-RSTRT
\$\$BRMSG2	CHECKPOINT-RESTART message writer
\$\$BRSTRB	Tape Restart
\$\$BRSTRT	RESTART message writer - Phase 2
\$\$BRSTR2	Tape and DASD verify for restart
\$\$BRSTR3	DASD verify for restart
\$\$BRSTR4	Tape Reposition
\$\$BSETFF	ISFMS load Phase 2 of SETFL
\$\$BSETFG	ISFMS load Phase 3 of SETFL
\$\$BSETFH	ISFMS load Phase 4 of SETFL
\$\$BSETFL	ISFMS load Phase 1 of SETFL
\$\$BSETL	ISMOD - SETL
\$\$BSOPEN	OLTEP OPEN
\$\$BSYSWR	Supervisor-nonresident attention
\$\$BTCNCL	Cancel routine
\$\$BTERM	Supervisor - program terminator
\$\$BTMEBG	Terminal test request - IBM 1030 Manual Entry and Badge Reader
\$\$BT1030	Terminal test module - IBM 1030
\$\$BT1050	Terminal test module - IBM 1050
\$\$BT1060	Terminal test module - IBM 1060
\$\$BT2260	Terminal test module - IBM 2260
\$\$BT2740	Terminal test module - IBM 2740
\$\$BT2848	Terminal test module - IBM 2848
\$\$BZCE01	CE Serviceability Programs
\$\$BZTIME	OLTEP

2. Job control and linkage editor are preferred core image library routines and begin with a dollar sign (\$) followed by an alphabetic character.

Job Control and Linkage Editor Routines for Disk Operating System

\$JOBCTLA	Job control program
\$JOBCTLD	Job control program
\$JOBCTLF	Job control program
\$JOBCTLG	Job control program
\$JOBCTLJ	Job control program
\$JOBCTLK	Job control program
\$LNKEDT	Linkage editor - initialize/overhead - Phase 1
\$LNKEDTA	Linkage editor - pass 2 processor Phase 7
\$LNKEDTC	Linkage editor - catalog processor Phase 8
\$LNKEDT0	Linkage editor 12-2-9 processor (ESD Only) Phase 2
\$LNKEDT2	Linkage editor 12-2-9 processor (other than ESD) Phase 3
\$LNKEDT4	Linkage editor - control card processor Phase 4
\$LNKEDT6	Linkage editor - control card processor Phase 5
\$LNKEDT8	Linkage editor - MAP processor Phase 6
\$MAINEOJ	Library routine update program

3. The names of the supervisor and IPL programs are \$\$A\$SUPx and \$\$A\$IPLx. An additional character (x) is used to distinguish phases of these programs.

Supervisor and IPL Programs for Disk Operating System

\$IPLRT2	IPL Program
\$\$A\$SUP1	Supervisor control program

Relocatable Module Identification

Note: All components of the DOS Relocatable Library are listed here. For each component that has module and phase names listed alongside each other, a one-to-one relationship between the modules and phases is not necessarily intended or implied.

<u>Component</u>	<u>Module Name</u>	<u>Phase Name</u>	<u>Linkage Edit Control Statements</u>	<u>Delete Statements</u>
CONTROL PROGRAM				DELETR IJB.ALL
Job Control	IJBJC	\$JOBCTLA	INCLUDE IJBJC	
	IJBJC1	\$JOBCTLD	// EXEC LNKEDT	
	IJBJC2	\$JOBCTLF		
	IJBJC3	\$JOBCTLG		
	IJBJC4	\$JOBCTLJ		
	IJBJC5	\$JOBCTLK		
	IJBJC6			
IPL	IJBIPL	\$IPLRT2	INCLUDE IJBIPL	
	IJBIP3		// EXEC LNKEDT	
Linkage Editor	IJBLE		INCLUDE IJBLE	
	IJBLE1	\$LNKEDT	// EXEC LNKEDT	
	IJBLBI	\$LNKEDT0		
		\$LNKEDT2		
		\$LNKEDT4		
		\$LNKEDT6		
		\$LNKEDT8		
	\$LNKEDTA			
	\$LNKEDTC			
Standard System Dump	IJBDUMPS		INCLUDE IJBDUMPS	
	IJBDMPS	\$\$BDUMP	// EXEC LNKEDT	
	IJBDMPBS	\$\$BDUMPB		
	IJBDMPDS	\$\$BDUMPD		
	IJBDMPFS	\$\$BDUMPF		
	IJBPDUMPS	\$\$BPDUMP		
	IJBPDUMS	\$\$BPDUM1		
Translating System Dump	IJBDUMPT		INCLUDE IJBDUMPT	
	IJBDMPT	\$\$BDUMP	// EXEC LNKEDT	
	IJBDMPBT	\$\$BDUMPB		
	IJBDMPDT	\$\$BDUMPD		
	IJBPMPT	\$\$BPDUMP		

Librarian

```
DSERV      IJBSL1      DSERV      INCLUDE IJBSL1
           // EXEC LNKEDT
RESTART    IJBRSTRT
MAINT      IJBSI2      MAINT      INCLUDE IJBSL2
           IJBLBA      MAINTA     // EXEC LNKEDT
           IJBLBC      MAINTCL
           IJBLBD      MAINTCN
           IJBLBE      MAINTDR
           IJBLBF      MAINTTEJP
           IJBLBG      MAINTR2
           IJBLBH      MAINTS2
           IJBLBL      MAINTUP
           IJBLBM      $MAINE0J
           IJBLBQ
           IJBLBZ
           IJBMCS
           IJBMDS
           IJBMDU
           IJBMIN
           IJBMIO
           IJBMUP
CSERV      IJBLBP      CSERV      INCLUDE IJBLBP
           // EXEC LNKEDT
RSERV      IJBSL3      RSERV      INCLUDE IJBSL3
           // EXEC LNKEDT
```

<u>Component</u>	<u>Module Name</u>	<u>Phase Name</u>	<u>Linkage Edit Control Statements</u>	<u>Delete Statements</u>
SSERV	IJBSL4	SSERV	INCLUDE IJBSL4 // EXEC LNKEDT	
CORGZ	IJBSI5 IJBLBJ IJBLBK IJBLBS IJBLBT IJBLBU IJBLBV	CORGZ CORGZ2 CORGZ1 CORGZ3 CORGZ4 CORGZ5	INCLUDE IJBSL5 // EXEC LNKEDT	
Common Librarian Modules	IJBLBA IJBLBC IJBLBD IJBLBE IJBLBF IJBLBG IJBLBH IJBLBI IJBLBJ IJBLBL			
CE Service-ability Programs	ILCEAID1 ILCEAID2	CEAIDLST CEAID CEAID001 CEAID002 CEAID003 CEAID004 CEAID005 CEAID006		
LANGUAGE TRANSLATORS				
Disk Work file assembler	IJQD16DW		INCLUDE IJQD16DW // EXEC LNKEDT	Disk Work Files DELETR IJQD16DW
Tape Work file assembler	IJQD16TW		INCLUDE IJQD16TW // EXEC LNKEDT	Tape Work Files DELETR IJQD16TW
Additional Core, 14K assembler	IJQD32		INCLUDE IJQD32 // EXEC LNKEDT	14K Tape and Disk Work Files DELETR IJQD32
Common Assembler Module	IJQDCOMN			All Assemblers DELETR IJQ.ALL
Additional Core, 44K Assembler	IJYASM		INCLUDE IJYASM // EXEC LNKEDT	44K Tape and Disk Work Files DELETR IJY.ALL

Note: The assembler relocatable modules are descriptive modules used by the linkage editor to incorporate appropriate assembler modules from the relocatable library into corresponding assembler phases for the core image library. The descriptive modules IJQD16DW,

IJQD16TW, IJQD32 and IJYASM are used to determine the appropriate corresponding variant of the assembler to be linkage edited from the assembler modules in the relocatable library. IBM-supplied systems with 6K supervisors contain the IJQD16DW variant. IBM-supplied systems with 8K supervisors contain the IJQD32 variant.

The descriptive module IJQDCOMN is nested within the 10K and 14K descriptive modules. This module describes the appropriate relocatable library modules and the corresponding core image library phase structure for phases common to all three assembler variants.

The following is a complete list of relocatable library modules and core image library phases for the assembler.

<u>Component</u>	<u>Module Name</u>	<u>Phase Name</u>	<u>Delete Statements</u>
	IJQDCOMN	ASSEMBLY	(Sample problems)
	*IJQD16DW	ASSEM00A**	DELETS Z.AS1
	+IJQD16TW	ASSEM00B**	DELETS Z.AS2
	#IJQD32	ASSEM02	DELETS Z.AS3
	IJQABT	ASSEN11D	
	IJQDIA	ASSEN11C	
	IJQDPP	ASSEN11B	
	IJQD0\$	ASSEM02A	
	IJAD0A	ASSEM03	
	IJQD2\$	ASSEM03A	
	IJQD2A	ASSEM04	
	IJQD3\$	ASSEM04A	
	IJQD3A	ASSEM04B	
	IJQD4P	ASSEM05	
	IJQD4M	ASSEM05A	
	IJQD4A	ASSEM05B	
	IJQD5A	ASSEM06	
	IJQD5P	ASSEN07	
	IJQD5M	ASSEN07A	
	IJQD7\$	ASSEN07I	
	IJQD7I	ASSEN08	
	IJQD8\$	ASSEN08A	
	IJQD9\$	ASSEN088	
	IJQD9I	ASSEN09	
	IJQRTA	ASSEN07C	
	IJQRTB	ASSEN08C	
	IJQ10\$	ASSEN09I	
	IJQ10B	ASSEN10	
	IJQ21A	ASSEN10B	
	IJQ21B	ASSEN11A	
		ASSEN11E	
		ASSEN12	
		ASSEN13	
		ASSEN14	

* required only for DWF variant

+ required only for TWF variant

required only for additional core storage variant S4

The following list is a complete list of the relocatable library modules and the core image library phases for the 44K assembler.

<u>Module Name</u>	<u>Phase Name</u>
IJYASM	ASSEMBLY
IJYF0	ASSEMBT
IJYABT	ASSEMF1
IJYCM	ASSEMFPP
IJYFD	ASSEMF8
IJYFI0	ASSEM3
IJYFPP	ASSEM3E
IJYF1	ASSEM7
IJYF2	
IJYF3	
IJYF3E	
IJYF7C	
IJYF7D	
IJYF7E	
IJYF7G	
IJYF7I	
IJYF7L	
IJYF7N	
IJYF7S	
IJYF7V	
IJYF7X	
IJYF8A	
IJYF8C	
IJYF8D	
IJYF8I	
IJYF8L	
IJYF8M	
IJYF8N	
IJYF8P	
IJYF8S	
IJYF8V	
IJYIN	
IJYRTA	
IJYRTB	

<u>Component</u>	<u>Module Name</u>	<u>Phase Name</u>	<u>Linkage Edit Control Statements</u>	<u>Delete Statements</u>
Autotest	IJVPT	ATLECONT	ACTION CLEAR	DELETR IJV.ALL
	IJVTAB	ATLEDT	INCLUDE IJVPT	(Sample
	IJVTC110	ATLEDT10	// EXEC LNKEDT	problem)
	IJVTC210	ATLEDT12		DELETS Z.AT1
	IJVTC310	ATLEDT14		
	IJVTC410	ATLEDT16		
	IJVTC510	ATLEDT18		
	IJVTC710	ATLEDT1A		
	IJVTE110	ATLEDT1B		
	IJVTE210	ATLEDT1C		
	IJVTF110	ATLEFC1		
	IJVTF110	ATLEFC2		
	IJVTH210	ATLEFC3		
	IJVTH310	ATLEFC4		
	IJVTD110	ATLEFC5		
	IJVTD210	ATLEFC7		
	IJVTI110	ATLEFD1		
	IJVTI110	ATLEFD2		
	IJVTA010	ATLEFE1		
	IJVLE	ATLEFE2		
	IJVSS110	ATLEFF1		
	IJVSS310	ATLEFG1		
		ATLEFH2		
		ATLEFH3		
		ATLEGO1		
		ATLEJCTV		
		\$\$BATST1		
		\$\$BATST3		

Note: The autotest calling book (IJVPT) will include the Autotest transients in the core image library.

COBOL	IJSCBD	IJSCBD	INCLUDE IJSCBD	DELETR IJS.ALL
	IJSCBI01	COBOL	// EXEC LNKEDT	This deletes
	IJSCBL02	COBOL000		the debug
	IJSCBL03	COBOL001		program also.
	IJSCBL04	COBOL002		(Sample
	IJSCBL05	COBOL003		problem)
	IJSCBL06	COBOL004		DELETES Z.CB1
	IJSCBL07	COBOL005		
	IJSCBI08	COBOL006		
	IJSCBL09	COBOL007		
	IJSCBL10	COBOL008		
	IJSCBL11	COBOL009		
	IJSCBL12	COBOL010		
	IJSCBL13	COBOL011		
	IJSCBL14	COBOL012		
	IJSCBL15	COBOL013		
	IJSCBL16	COBOL014		
	IJSCBL17	COBOL015		
	IJSCBL18	COBOL016		
	IJSCBL19	COBOL017		
	IJSCBL20	COBOL018		
IJSCBL21	COBOL019			

<u>Component</u>	<u>Module Name</u>	<u>Phase Name</u>	<u>Linkage Edit Control Statements</u>	<u>Delete Statements</u>
	IJSCBL22	COBOL020		
	IJSCBL23	COBOL021		
	IJSCBL24	COBOL022		
	IJSCBL25	COBOL023		
	IJSCBL26	COBOL024		
	IJSCBL27	COBOL025		
	IJSCBL28	COBOL027		
	IJSCBL29	COBOL028		
	IJSCBL31	COBOL029		
	IJSCBL32	COBOL030		
	IJSCBL33	COBOL031		
	IJSCBL34	COBOL032		
	IJSCBL35	COBOL033		
	IJSCBL36	COBOL034		
	IJSCBL37	COBOL035		
	IJSCBL38	COBOL036		
	IJSCBL39	COBOL037		
	IJSCBL40	COBOL038		
	IJSCBL41	COBOL039		
	IJSCBL42	COBOL040		
	IJSCBL43	COBOL041		
	IJSCBL44	COBOL042		
	IJSCBL45	COBOL043		
	IJSCBL46	COBOL044		
	IJSCBL47	COBOL050		
	IJSCBL48	COBOL055		
	IJSCBL49			
	IJSCBL50			
	IJSCBL55			
COBOL Debug	IJSDDDB IJSCBL60	DEBUG	INCLUDE IJSDDDB // EXEC LNKEDT	
FORTRAN	ILFFO ILFFORT ILFPAR ILFALL ILFUNF ILFGEN ILFEXT ILFROL ILFTRBK	FFORTRAN FFORT1 FFORT2 FFORT3 FFORT4 FFORT5 FFORT9 FFORTRBK	INCLUDE ILFFO // EXEC LNKEDT	DELETR ILFFO DELETR ILFFORT DELETR ILFPAR DELETR ILFALL DELETR ILFUNF DELETR ILFGEN DELETR ILFEXT DELETR ILFROL DELETR ILFTRBK DELETS Z.ILFSAMPL (Sample Problem) DELETS Z.ILFMERGE (Compatibility Merge Book)
Basic FORTRAN	IJTFO IJTFO1 IJTFO2 IJTFO3 IJTFO4	FORTRAN FORTREL FORTRGE FORTRPU	INCLUDE IJTFO // EXEC LNKEDT	DELETR IJTFO DELETR IJTFO1 DELETR IJTFO2 DELETR IJTFO3 DELETR IJTFO4 (Sample problem) DELETS Z.FO1

```

PL/I (SYSIPT, IJXA00 PL/I INCLUDE IJXPLI DELFTR IJX.ALL
SYSPCH, SYSLST // EXEC LNKEDT (Sample
never on 2311) problem)
DELETS Z.PL1

```

```

PL/I (SYSIPT, IJXA00D PL/I INCLUDE IJXPLID
SYSPCH, SYSLST // EXEC LNKEDT
may be on 2311)

```

Note: The two compiler versions differ in the first phase only. The following list applies to both versions.

<u>Component</u>	<u>Module Name</u>	<u>Phase Name</u>	<u>Linkage Edit Control Statements</u>	<u>Delete Statements</u>
	IJXA10	PL/IA10		
	IJXA20	PL/IA20		
	IJXA25	PL/IA25		
	IJXA27	PL/IA27		
	IJXA30	PL/IA30		
	IJXA35	PL/IA35		
	IJXA45	PL/IA45		
	IJXA50	PL/IA50		
	IJXA60	PL/IA60		
	IJXA65	PL/IA65		
	IJXB10	PL/IB10		
	IJXB15	PL/IB15		
	IJXB20	PL/IB20		
	IJXB25	PL/IB25		
	IJXB30	PL/IB25A		
	IJXB40	PL/IB30		
	IJXB70	PL/IB40		
	IJXB75	PL/IB70		
	IJXB80	PL/IB75		
	IJXB85	PL/IB80		
	IJXB87	PL/IB85		
	IJXB90	PL/IB85A		
	IJXB92	PL/IB87		
	IJXB95	PL/IB90		
	IJXB97	PL/IB92		
	IJXC00	PL/IB95		
	IJXC03	PL/IB97		
	IJXC25	PL/IC00		
	IJXC30	PL/IC03		
	IJXC31	PL/IC25		
	IJXC32	PL/IC30		
	IJXC33	PL/IC31		
	IJXC34	PL/IC32		
	IJXC34A	PL/IC33		
	IJXC34B	PL/IC34		
	IJXC35	PL/IC34A		

<u>Component</u>	<u>Module Name</u>	<u>Phase Name</u>	<u>Linkage Edit Control Statements</u>	<u>Delete Statements</u>
	IJXC37	PL/IC34B		
	IJXC40	PL/IC35		
	IJXC50	PL/IC37		
	IJXC55	PL/IC40		
	IJXC60	PL/IC50		
	IJXC65	PL/IC55		
	IJXC85	PL/IC60		
	IJXC86	PL/IC65		
	IJXC95	PL/IC85		
	IJXD00	PL/IC86		
	IJXD03	PL/IC95		
	IJXD05	PL/ID00		
	IJXD10	PL/ID03		
	IJXD11	PL/ID05		
	IJXD15	PL/ID10		
	IJXD17	PL/ID11		
	IJXD20	PL/ID15		
	IJXD20A	PL/ID17		
	IJXD40	PL/ID20		
	IJXD70	PL/ID20A		
	IJXD75	PL/ID40		
	IJXD80	PL/ID70		
	IJXE25	PL/ID75		
	IJXE25A	PL/ID80		
	IJXE25B	PL/IE25		
	IJXE25C	PL/IE25A		
	IJXE25D	PL/IE25B		
	IJXE25E	PL/IE25C		
	IJXE25F	PL/IE25D		
	IJXE25G	PL/IE25E		
	IJXE25H	PL/IE25F		
	IJXE25I	PL/IE25G		
	IJXE25J	PL/IE25H		
	IJXE25K	PL/IE25I		
	IJXE50	PL/IE25J		
	IJXE55	PL/IE25K		
	IJXE60	PL/IE50		
	IJXE61	PL/IE55		
	IJXF25	PL/IE60		
	IJXF35	PL/IE60A		
	IJXF50	PL/IF25		
	IJXF75	PL/IF35		
	IJXF90	PL/IF50		
	IJXF95	PL/IF75		
	IJXG00	PL/IF90		
	IJXG01	PL/IF95		
	IJXG15	PL/IG00		
	IJXG17	PL/IG01		
	IJXG17B	PL/IG15		
	IJXG17D	PL/IG17		
	IJXG17E	PL/IG17B		
	IJXG17R	PL/IG17D		
	IJXG17S	PL/IG17E		
	IJXG17X	PL/IG17R		
	IJXG17Y	PL/IG17S		
	IJXG20	PL/IG17X		
	IJXG25	PL/IG17Y		
	IJXG30	PL/IG20		
	IJXG31	PL/IG25		
	IJXG40	PL/IG30		
	IJXG55	PL/IG31		

<u>Component</u>	<u>Module Name</u>	<u>Phase Name</u>	<u>Linkage Edit Control Statements</u>	<u>Delete Statements</u>
	*IJXPLOSE	PL/IG40		
	*IJXS00	PL/IG55		
	*IJXS10	\$\$BPLOSE		
	*IJXS20	\$IJKS00		
	*IJXS30	\$IJKS10		
	*IJXS40	\$IJKS20		
	*IJXS50	\$IJKS30		
	*IJXS60	\$IJKS40		
	*IJXS70	\$IJKS50		
		\$IJKS60		
		\$IJKS70		

Object program IJXSYSA
I/O modules for IJXSYSI
2311**

*At system generation time, these phases are cataloged into the core image library along with the PL/I compiler.

**These routines are either renamed to replace IJKSYSA or IJKSYSI respectively or deleted from the operational volume.

<u>Ccponent</u>	<u>Module Name</u>	<u>Phase Name</u>	<u>Linkage Edit Control Statements</u>	<u>Delete Statements</u>
RPG	IJRRG	RPG1	INCLUDE IJRRG	DELETR IJR.ALL
	IJR000	RPG10010	// EXEC LNKEDT	(Sample problem)
	IJR010	RPG10020		DELETS Z.RG1
	IJR020	RPG10025		
	IJR025	RPG10030		
	IJR030	RPG10040		
	IJR039	RPG10050		
	IJR040	RPG10060		
	IJR049	RPG10070		
	IJR050	RPG10080		
	IJR059	RPG10090		
	IJR060	RPG10100		
	IJR069	RPG10110		
	IJR070	RPG10120		
	IJR079	RPG10130		
	IJR080	RPG10140		
	IJR089	RPG10150		
	IJR090	RPG10160		
	IJR099	RPG10170		
	IJR100	RPG1018A		
	IJR109	RPG1018G		
	IJR110	RPG10180		
	IJR119	RPG10190		
	IJR120	RPG10200		
	IJR129	RPG10210		
	IJR130	RPG10220		
	IJR139	RPG10230		
	IJR140	RPG10240		
	IJR149			
	IJR150			
	IJR159			
	IJR160			
	IJR169			
	IJR170			
	IJR179			
	IJR18A			
	IJR18F			
	IJR18G			
	IJR18H			
	IJR180			
	IJR189			
	IJR190			
	IJR199			
	IJR200			
	IJR209			
	IJR210			
	IJR219			
	IJR220			
	IJR229			
	IJR230			
	IJR239			
	IJR240			
	IJR241			
	IJR242			
	IJR243			
	IJR244			
	IJR245			
	IJR246			
	IJR247			
	IJR249			

<u>Component</u>	<u>Module Name</u>	<u>Phase Name</u>	<u>Linkage Edit Control Statements</u>	<u>Delete Statements</u>
SORT/MERGE (see <u>Appendix D</u> for Disk Sort/Merge)				
Tape	IJPSM	TSRT	INCLUDE IJPSM	DELETR IJP.ALL
	IJPSM001	TSRTP002	// LBLTYP TAPE	(Sample
	IJPSM002	TSRTP003	// EXEC LNKEDT	problems)
	IJPSM003	TSRTP004		DELETS Z.SM1
	IJPSM004	TSRTP005		
		TSRTP006		
		TSRTP007		
		TSRTP008		
		TSRTP101		
		TSRTP102		
		TSRTP103		
		TSRTP104		
		TSRTP105		
		TSRTP201		
		TSRTP202		
		TSRTP203		
		TSRTP204		
		TSRTP301		
		TSRTP302		
		TSRTP303		
UTILITIES				DELETR IJW.ALL
				(Sample
				problems)
				DELETS Z.UTDKPR1
				DELETS Z.UTDCPR1
				DELETS Z.UTTPRR1
Alternate Track Assignment Data Cell	IJWALTM	ATAM	INCLUDE IJWALTM	DELETR IJWALTM
	IJWAM1	ATAM2	// EXEC LNKEDT	DELETR IJWAM1
	IJWAM2	ATAM3		DELETR IJWAM2
	IJWAM3	ATAM4		DELETR IJWAM3
	IJWAM4	ATAM5		DELETR IJWAM4
	IJWAM5			DELETR IJWAM5
Alternate Track Assignment-Disk	IJWAD	ATAD	INCLUDE IJWAD	DELETR IJWAD
	IJWAD1	ATAD2	// EXEC LNKEDT	DELETR IJWAD1
	IJWAD2	ATAD3		DELETR IJWAD2
	IJWAD3	ATAD4		DELETR IJWAD3
	IJWAD4	ATAD5		DELETR IJWAD4
	IJWAD5			DELETR IJWAD5
Card-to-Disk	IJWCD	CDDK	INCLUDE IJWCD	DELETR IJWCD
	IJWCD1	CDDK2	PHASE CDDK5,	DELETR IJWCD1
			IJWCDCS2,NOAUTO	
	IJWCD3	CDDK3	INCLUDE IJWLAB	DELETR IJWCD3
	IJWCD4	CDDK4	// EXEC LNKEDT	DELETR IJWCD4
		CDDK5		
Card-to-Printer/Punch	IJWCP	CDPP	INCLUDE IJWCP	DELETR IJWCP
	IJWCP1	CDPP2	PHASE CDPP5,	DELETR IJWCP1
			IJWCP5,NOAUTO	
	IJWCP3	CDPP3	INCLUDE IJWLAB	DELETR IJWCP2
	IJWCP4	CDPP4	// EXEC LNKEDT	DELETR IJWCP3
		CDPP5		DELETR IJWCP4

	Module	Phase	Linkage Edit Control	Delete
<u>Component</u>	<u>Name</u>	<u>Name</u>	<u>Statements</u>	<u>Statements</u>
Card-to-Tape	IJWCT	CDTP	INCLUDE IJWCT	DELETR IJWCT
	IJWCT1	CDTP2	PHASE CDTP5, IJWCTCS2,NOAUTO	DELETR IJWCT1
	IJWCT3	CDTP3	INCLUDE IJWLAB	DELETR IJWCT3
	IJWCT4	CDTP4	// LBLTYP TAPE	DELETR IJWCT4
	IJWLAB	CDTP5	// EXEC LNKEDT	
Clear Data Cell	IJWCLM	CLDC	INCLUDE IJWCLM	DELETR IJWCLM
	IJWCLM1	CLDC2	// EXEC LNKEDT	DELETR IJWCLM1
	IJWCLD2	CLDC3		
	IJWCLD3			
Clear Disk	IJWCLD	CLRDSK	INCLUDE IJWCLD	DELETR IJWCLD
	IJWCLD1	CLR2	// EXEC LNKEDT	DELETR IJWCLD1
	IJWCLD2	CLR3		DELETR IJWCLD2
	IJWCLD3			DELETR IJWCLD3
Copy Disk to Card	IJWKC	CRDC	INCLUDE IJWKC	DELETR IJWKC
	IJWKC1	CRDC2	// LBLTYP NSD (nn)	DELETR IJWKC1
	IJWKC2		// EXEC LNKEDT	DELETR IJWKC2
Copy Disk to Disk	IJWRD	CRDD	INCLUDE IJWRD	DELETR IJWRD
	IJWRD1	CRDD2	// LBLTYP NSD (nn)	DELETR IJWRD1
	IJWRD2		// EXEC LNKEDT	DELETR IJWRD2
Copy Disk or Data Cell to Tape	IJWKT	CRDT	INCLUDE IJWKT	DELETR IJWKT
	IJWKT1	CRDT2	// LBLTYP NSD(nn)	DELETR IJWKT1
	IJWKT2		// EXEC LNKEDT	DELETR IJWKT2
Data Cell-to-Data Cell	IJWMM	DCDC	INCLUDE IJWMM	DELETR IJWMM
	IJWMM1	DCDC2	PHASE DCDC5, IJWMMCS2,NOAUTO	DELETR IJWMM1
	IJWDD3	DCDC3	INCLUDE IJWLAB	
	IJWDD4	DCDC4	// EXEC LNKEDT	
		DCDC5		
Data Cell-to-Disk	IJWMD	DCDK	INCLUDE IJWMD	DELETR IJWMD
	IJWMD1	DCDK2	PHASE DCDK5, IJWMDCS2,NOAUTO	DELETR IJWMD1
	IJWDD3	DCDK3	INCLUDE IJWLAB	
	IJWDD4	DCDK4	// EXEC LNKEDT	
		DCDK5		
Data Cell-to-Printer	IJWMP	DCPR	INCLUDE IJWMP	DELETR IJWMP
	IJWMP1	DCPR2	PHASE DCPR5, IJWMPCS2,NOAUTO	DELETR IJWMP1
	IJWDP3	DCPR3	INCLUDE IJWLAB	
	IJWDT4	DCPR4	// EXEC LNKEDT	
		DCPR5		

<u>Component</u>	<u>Module Name</u>	<u>Phase Name</u>	<u>Linkage Edit Control Statements</u>	<u>Delete Statements</u>
Data Cell-to-Tape	IJWMT	DCTP	INCLUDE IJWMT	DELETR IJWMT
	IJWMT1	DCTP2	PHASE DCTP5,	DELETR IJWMT1
	IJWDT3		IJWMTCS2,NOAUTO	
	IJWDT4	DCTP3	INCLUDE IJWLAB	
		DCTP4	// LBLTYP TAPE	
		DCTP5	// EXEC LNKEDT	
Disk-to-Card	IJWDC	DKCD	INCLUDE IJWDC	DELETR IJWDC
	IJWDC1	DKCD2	PHASE DKCD5,	DELETR IJWDC1
			IJWDCCS2,NOAUTO	
	IJWDC3	DKCD3	INCLUDE IJWLAB	DELETR IJWDC3
	IJWDC4	DKCD4	// EXEC LNKEDT	DELETR IJWDC4
		DKCD5		
Disk-to-Data Cell	IJWDM	DKDC	INCLUDE IJWDM	DELETR IJWDM
	IJWDM1	DKDC2	PHASE DKDC5,	DELETR IJWDM1
	IJWDD3		IJWDMCS2,NOAUTO	
	IJWDD4	DKDC3	INCLUDE IJWLAB	
		DKDC4	// EXEC LNKEDT	
		DKDC5		
Disk-to-Disk	IJWDD	DKDK	INCLUDE IJWDD	DELETR IJWDD
	IJWDD1	DKDK2	PHASE DKDK5,	DELETR IJWDD1
			IJWDDCS2,NOAUTO	
	IJWDD3	DKDK3	INCLUDE IJWLAB	DELETR IJWDD3
	IJWDD4	DKDK4	// EXEC LNKEDT	DELETR IJWDD4
		DKDK5		
Disk-to-Printer	IJWDP	DKPR	INCLUDE IJWDP	DELETR IJWDP
	IJWDP1	DKPR2	PHASE DKPR5,	DELETR IJWDP1
			IJWDPCS2,NOAUTO	
	IJWDP3	DKPR3	INCLUDE IJWLAB	DELETR IJWDP3
	IJWDP4	DKPR4	// EXEC LNKEDT	DELETR IJWDP4
		DKPR5		
Disk-to-Tape	IJWDT	DKTP	INCLUDE IJWDT	DELETR IJWDT
	IJWDT1	DKTP2	PHASE DKTP5,	DELETR IJWDT1
			IJWDTCS2,NOAUTO	
	IJWDT3	DKTP3	INCLUDE IJWLAB	DELETR IJWDT3
	IJWDT4	DKTP4	// LBLTYP TAPE	DELETR IJWDT4
		DKTP5	// EXEC LNKEDT	
Initialize Data Cell	IJWIM	INTM	INCLUDE IJWIM	DELETR IJWIM
	IJWIM1	INTM2	// EXEC LNKEDT	DELETR IJWIM1
	IJWIM2	INTM3		DELETR IJWIM2
	IJWIM3	INTM4		DELETR IJWIM3
	IJWIM4			DELETR IJWIM4
Initialize Disk	IJWID	INTD	INCLUDE IJWID	DELETR IJWID
	IJWID1	INTD2	// EXEC LNKEDT	DELETR IJWID1
	IJWID2	INTD3		DELETR IJWID2
	IJWID3			DELETR IJWID3
	IJWID4			DELETR IJWID4
Restore Card to Disk	IJWRC	CRCD	INCLUDE IJWRC	DELETR IJWRC
	IJWRC1		// LBLTYP NSD(nn) // EXEC LNKEDT	DELETR IJWRC1
Restore Tape to Disk or Data Cell	IJWRT	CRTD	INCLUDE IJWRT	DELETR IJWRT
	IJWRT1		// LBLTYP NSD(nn)	DELETR IJWRT1
			// EXEC LNKEDT	

<u>Component</u>	<u>Module Name</u>	<u>Phase Name</u>	<u>Linkage Edit Control Statements</u>	<u>Delete Statements</u>
Tape-to-Card	IJWTC	TPCD	INCLUDE IJWTC	DELETR IJWTC
	IJWTC1	TPCD2	PHASE TPCD5, IJWTCCS2,NOAUTO	DELETR IJWTC1
	IJWTC3	TPCD3	INCLUDE IJWLAB	DELETR IJWTC3
	IJWTC4	TPCD4 TPCD5	// LBLTYP TAPE // EXEC LNKEDT	DELETR IJWTC4
Tape Compare	IJWTPCP	TPCP	PHASE TPCP,*, NOAUTO	DELETR IJWTPCP
	IJWTCP	TPCP	INCLUDE IJWTCP	DELETR IJWTCP
	IJWTCP2	TPCP2	INCLUDE IJWTCP	DELETR IJWTCP2
	IJWTCP3	TPCP3	INCLUDE IJWCPD1	DELETR IJWTCP3
	IJWXIT		INCLUDE IJWXIT INCLUDE IJWTPCP // LBLTYP TAPE // EXEC LNKEDT	DELETR IJWXIT
Tape-to-Data Cell	IJWTM	TPDC	INCLUDE IJWTM	DELETR IJWTM
	IJWTM1	TPDC2	PHASE TPDC5, IJWTMCS2,NOAUTO	DELETR IJWTM1
	IJWTD3	TPDC3	INCLUDE IJWLAB	
	IJWTD4	TPDC4 TPDC5	// LBLTYP TAPE // EXEC LNKEDT	
Tape to Disk	IJWTD	TPDK	INCLUDE IJWTD	DELETR IJWTD
	IJWTD1	TPDK2	PHASE TPDK5, IJWTDSC2,NOAUTO	DELETR IJWTD1
	IJWTD3	TPDK3	INCLUDE IJWLAB	DELETR IJWTD3
	IJWTD4	TPDK4 TPDK5	// LBLTYP TAPE // EXEC LNKEDT	DELETR IJWTD4
Tape to Printer	IJWTP	TPPR	INCLUDE IJWTP	DELETR IJWTP
	IJWTP1	TPPR2	PHASE TPPR5, IJWTPCS2,NOAUTO	DELETR IJWTP1
	IJWTP3	TPPR3	INCLUDE IJWLAB	DELETR IJWTP3
	IJWTP4	TPPR4 TPPR5	// LBLTYP TAPE // EXEC LNKEDT	DELETR IJWTP4
Tape to Tape	IJWTT	TPTP	INCLUDE IJWTT	DELETR IJWTT
	IJWTT1	TPTP2	PHASE TPTP5, IJWTTCS2,NOAUTO	DELETR IJWTT1
	IJWTT3	TPTP3	INCLUDE IJWLAB	DELETR IJWTT3
	IJWTT4	TPTP4 TPTP5	// LBLTYP TAPE // EXEC LNKEDT	DELETR IJWTT4
VTOC Display (BJS)	IJWLVB	LISTVTOC	INCLUDE IJWLVB	DELETR IJWLVB
	IJWLVI	\$\$BLISTV	// EXEC LNKEDT	
	IJWLVT			
VTOC Display (MPS)	IJWLVM	LISTVTOC	INCLUDE IJWLVM	DELETR IJWLVM
	IJWLVI	\$\$BLISTV	// EXEC LNKEDT	
	IJWLVT			

Note: Each of the above file to file utility programs share two common modules. These are:

IJWGEN	DELETR IJWGEN
IJWLAB	DELETR IJWLAB

The file-to-file data cell programs share the third and fourth modules from the counterpart disk programs.

The Clear Data Cell program shares the modules IJWCLD2 and IJWCLD3 with the clear disk program.

<u>Component</u>	<u>Module Name</u>	<u>Phase Name</u>	<u>Linkage Edit Control Statements</u>	<u>Delete Statements</u>
------------------	--------------------	-------------------	--	--------------------------

Note: If a user label-checking routine is to be included instead of the IBM-supplied label routine, this module is included instead of the IBM-supplied module (i.e., IJWLAB). See the complete description of module names, phase names and the procedure for including user modules in IBM System/360 Disk and Tape Operating Systems, Utility Programs: Specifications, Form C24-3465.

Vocabulary File	IJNVBL	VOC72BL	INCLUDE IJNVOC	DELETR IJN.ALL
Utility Program	IJNVCT	VOC72BM	// LBLTYP NSD(01)	
	IJNVER	VOC72BN	// EXEC LNKEDT	
	IJNVIO	VOC72CR		
	IJNVLI	VOC72ER		
	IJNVLO	VOC72LI		
	IJNVOC	VOC72LO		
	IJNVUP	VOC72PR		
		VOC72UP		
		VOC72UQ		
		VOC72UR		
		VOC72UT		

COBCL SUBROUTINE

IHD00000	DELETR IHD.ALL
IHD00100	
IHD00200	
IHD00300	
IHD00400	
IHD00500	
IHD00600	
IHD00700	
IHD00800	
IHD00900	
IHD01000	
IHD01100	
IHD01200	
IHD01300	
IHD01400	
IHD01500	
IHD01600	
IHD01700	
IHD01800	
IHD01900	
IHD02000	
IHD02100	
IHD02200	
IHD02300	
IHD02400	
IHD02500	
IHD02600	
IHD02700	

<u>Component</u>	<u>Module Name</u>	<u>Phase Name</u>	<u>Linkage Edit Control Statements</u>	<u>Delete Statements</u>
	IHD02800			
	IHD02900			
	IHD03000			
	IHD03100			
	IHD03200			
	IHD03300			
	IHD03400			
	IHD03500			
	IHD03600			
	IHD03700			
	IHD03800			
	IHD03900			
	IHD04000			
	IHD04100			
Basic FORTRAN SUBROUTINE				
	IJTAAFR			DELETR IJT.ALL
	IJTACOM			
	IJTACON			
	IJTADIR			
	IJTADXD			
	IJTADXI			
	IJTAIXI			
	IJTAPST			
	IJTARBE			
	IJTARXI			
	IJTARXR			
	IJTDVCK			
	IJTEXPN			
	IJTFDMP			
	IJTFIOS			
	IJTFXIT			
	IJTTHXC			
	IJTIFIX			
	IJTLEXP			
	IJTLLOG			
	IJTLSCN			
	IJTLSQT			
	IJTLTAN			
	IJTLTNH			
	IJTMAXD			
	IJTMODI			
	IJTMODR			
	IJTOVRF			
	IJTSINT			
	IJTSLIT			
	IJTSLOG			
	IJTSMX0			
	IJTSMX1			
	IJTSSCN			
	IJTSSQT			
	IJTSTAN			
	IJTSTNH			

<u>Component</u>	<u>Module Name</u>	<u>Phase Name</u>	<u>Linkage Edit Control Statements</u>	<u>Delete Statements</u>
FORTTRAN	SUBROUTINE			DELETR ILF.ALL
	ILFACOM			
	ILFADCON			
	ILFCLABS			
	ILFCLAS			
	ILFCLEXP			
	ILFCILOG			
	ILFCLSCN			
	ILFCLSQT			
	ILFCSABS			
	ILFCSAS			
	ILFCSEXP			
	ILFCSLOG			
	ILFCSSCN			
	ILFCSSQT			
	ILFDEBUG			
	ILFDIOCS			
	ILFFCDXI			
	ILFFCXPI			
	ILFFDUMP			
	ILFFDVCH			
	ILFFDXPD			
	ILFFDXPI			
	ILFFEXIT			
	ILFFINT			
	ILFFIOCS			
	ILFFIXPI			
	ILFFMAXD			
	ILFFMAXI			
	ILFFMAXR			
	ILFFOVER			
	ILFFRXPI			
	ILFFRXPR			
	ILFFSLIT			
	ILFGHTAB			
	ILFIBCOM			
	ILFIBERR			
	ILFLASCN			
	ILFLATN2			
	ILFLERF			
	ILFLEXP			
	ILFLGAMA			
	ILFLLOG			
	ILFLSCN			
	ILFLSCNH			
	ILFLSQRT			
	ILFITANH			
	ILFLTNCT			
	ILFNAMEL			
	ILFSASCN			
	ILFSATN2			
	ILFSERF			
	ILFSEXP			
	ILFSGAMA			
	ILFSLOG			
	ILFSSCN			
	ILFSSCNH			
	ILFSSQRT			
	ILFSTANH			
	ILFSTNCT			
	ILFTRBK			
	ILFUNTAB			

<u>Component</u>	<u>Module Name</u>	<u>Phase Name</u>	<u>Linkage Edit Control Statements</u>	<u>Delete Statements</u>
PL/I SUBROUTINES	IJKEXHC			
	IJKQALM			DELETR IJK.ALL
	IJKQASM			
	IJKQBLA			
	IJKQBSA			
	IJKQCLA			
	IJKQCSA			
	IJKQDLA			
	IJKQDSA			
	IJKQLLA			
	IJKQLSA			
	IJKQNLD			
	IJKQNSD			
	IJKQQLM			
	IJKQQSM			
	IJKQRLB			
	IJKQRSB			
	IJKQSLD			
	IJKQSSD			
	IJKQTLB			
	IJKQTSB			
	IJKRBBM			
	IJKRBIM			
	IJKRBKA			
	IJKREBM			
	IJKRELM			
	IJKREPM			
	IJKRESM			
	IJKRGIM			
	IJKRGKM			
	IJKRMBX			
	IJKRMLX			
	IJKRMPX			
	IJKRMSX			
	IJKRSBM			
	IJKRSLM			
	IJKRSPM			
	IJKRSSM			
	IJKRUBM			
	IJKRWBM			
	IJKRWLM			
	IJKRWPM			
	IJKRWSM			
	IJKRXLM			
	IJKRXSA			
	IJKSDMP			
	IJKSDTM			
	IJKSTMM			
	IJKSYS A			
	IJKSYS I			
	IJKSZBA			
	IJKSZCA			

<u>Component</u>	<u>Module Name</u>	<u>Phase Name</u>	<u>Linkage Edit Control Statements</u>	<u>Delete Statements</u>
	IJKSZLM			
	IJKTCBM			
	IJKTCUM			
	IJKTDIM			
	IJKTDPD			
	IJKTFDM			
	IJKTFMM			
	IJKTGDI			
	IJKTICM			
	IJKTLIM			
	IJKTIOM			
	IJKTLTB			
	IJKTPSM			
	IJKTRGM			
	IJKTRON			
	IJKTSIM			
	IJKTSTM			
	IJKTXCF			
	IJKTXRM			
	IJKTXRN			
	IJKVBCM			
	IJKVBTM			
	IJKVCBM			
	IJKVCEM			
	IJKVCFM			
	IJKVCPM			
	IJKVCTM			
	IJKVECM			
	IJKVFCM			
	IJKVGIM			
	IJKVIGM			
	IJKVIIM			
	IJKVNPM			
	IJKVPCM			
	IJKVPNM			
	IJKVPRM			
	IJKVRPM			
	IJKVTBM			
	IJKVTCM			
	IJKXTBM			
	IJXSYSA			
	IJXSYSI			

Telecommunications

BTAM RELOCATABLE MODULE AND CORE IMAGE PHASE IDENTIFICATION

Relocatable Module Name

IJLASC	Table of special characters in ASCII for BSC
IJLEBD	Table of special characters in EBCDIC for Binary Synchronous Communication (BSC)
IJLTCD	Table of special characters in 6-bit transcode (for Binary Synchronous Communications)

IJL0BY	BSC Channel Program Models for Switched lines using No ID Verification (CPU-to-CPU)
IJL0BZ	BSC Channel Program Models for Nonswitched lines (CPU-to-CPU)
IJL0EZ	World Trade Telegraph Terminals (WTTA)
IJL00Y	IBM 7770
IJL10Y	IBM 7772
IJL01J	IBM 1030 (Auto Poll)
IJL01Z	IBM 1030
IJL02J	IBM 1060 (Auto Poll)
IJL02Z	IBM 1060
IJL03Z	IBM 2848 Remote
IJL04Z	AT&T 83B3
IJL05Z	Western Union 115A
IJL07J	IBM 1050 Nonswitched (Auto Poll)
IJL07Y	IBM 1050 Switched
IJL07Z	IBM 1050 Nonswitched
IJL08H	IBM 2740 with Station Control (Auto Poll)
IJL08M	IBM 2740 with Dial, Transmit Control, and Checking
IJL08P	IBM 2740 with Station Control and Checking
IJL08Q	IBM 2740 with Dial and Checking
IJL08R	IBM 2740 with Checking
IJL08U	IBM 2740 with Dial and Transmit Control
IJL08X	IBM 2740 with Station Control
IJL08Y	IBM 2740 with Dial
IJL08Z	IBM 2740 Basic
IJL089	IBM 2740 with Station Control and Checking (Auto Poll)
IJL09Y	TWX 33
IJLWTZ	WTTA Subroutines
IJL@6Z	Table Generation for 2260 Local Channel Program

The following relocatable modules are BSC channel program models for switched lines using ID verification (CPU-to-CPU). The correspondence between relocatable module name and the codes which appear in the FEATURE operand sublist in the DTFBT macro instruction is indicated.

IJLOBA	RIW
IJLOBC	SIW,RXW
IJLOBE	SXW,RXW
IJLOBG	SIX,RXW
IJLOBI	RXW
IJLOBK	SIW,RIX
IJLOBM	SXW,RIX
IJLOBO	SIX,RIX
IJLOBQ	RIX
IJLOBS	SIW
IJLOBU	SXW
IJLOBW	SIX
IJLOB4	SIW,RIW
IJLOB6	SXW,RIW
IJLOB8	SIX,RIW
IJLOCY	Channel Program Models for IBM 1130 on a point to point switched line
IJLOCZ	Channel Program Models for IBM 1130 on a point to point non-switched line
IJLODY	IBM 2780 switched point to point
IJLODZ	IBM 2780 non-switched point to point
IJL1BZ	BCS S/360 Model 20 Multipoint
IJL1CZ	Channel Program Models for a multidropped IBM 1130 on a multipoint line
IJL1DZ	IBM 2780 multipoint for EBCDIC
IJL2DZ	IBM 2780 Multipoint for USASCII or Transcode

The following relocatable modules are translate tables for the devices indicated.

IJLRASA	Translates from USASCII to EBCDIC for BSC
IJLRCTW	Translates from ITA2 to EBCDIC (World Trade Teletype)
IJLRCT1	Translates from BAUDOT to EBCDIC
IJLRCT2	Translates from TWX to EBCDIC
IJLRCT3	Translates from ZSC3 to EBCDIC (World Trade Teletype)
IJLRC30	Translates from 1080 to EBCDIC

IJLRC40	Translates from 2740 to EBCDIC (lowercase)
IJLRC50	Translates from 1050 to EBCDIC (lowercase)
IJLRC60	Translates from 1060 to EBCDIC
IJLRC80	Translates from 6-Bit TRANSCODE to EBCDIC
IJLRF40	Translates from 2740 to EBCDIC (uppercase)
IJLRF50	Translates from 1050 to EBCDIC (uppercase)
IJLRFSCI	Translates from USASCII to EBCDIC with 2848 attached to 2701 via IBM Terminal Control Type III.
IJLSASA	Translates from EBCDIC to USASCII for BSC
IJLSCTW	Translates from EBCDIC to ITA2 (World Trade Teletype)
IJLSCT1	Translates from EBCDIC to BAUDOT
IJLSCT2	Translates from EBCDIC to TWX
IJLSCT3	Translates from EBCDIC to ZSC3 (World Trade Teletype)
IJLSD30	Translates from EBCDIC to 1030
IJLSD40	Translates from EBCDIC to 2740
IJLSD50	Translates from EBCDIC to 1050
IJLSD60	Translates from EBCDIC to 1060
IJLSD80	Translates from EBCDIC to 6-Bit TRANSCODE
IJLSSCI	Translates from EBCDIC to USASCII with 2848 attached to 2701 via IBM Terminal Control Type III

Transient Phase Names

\$\$ANERP2	Terminal Test Module to Write out Results of BSC On-Line
\$\$ANERR2	BTAM Error Recovery Message Writer, Phase 1
\$\$ANERR3	BTAM Error Recovery Message Writer, Phase 2
\$\$ANERR4	BTAM Error Recovery Message Writer, Phase 3
\$\$ANERR5	BTAM Error Recovery Message Writer, Phase 4
\$\$BCTC01	Close Routine
\$\$BETPRT	Error Threshold Message
\$\$BHDRCK	Terminal Test Request Validation and Comparison
\$\$BLEPRT	Line Error Print Routine
\$\$BIOPEN	Line OPEN Routine
\$\$BOTC01	OPEN Routine

\$\$BRESPL	Reset Polling Lines
\$\$BTCNCL	Cancel Routine
\$\$BTMEBG	Terminal Test Request for IBM 1030 Manual Entry and Badge Reader
\$\$BT1030	Terminal Test Module for IBM 1030
\$\$BT1050	Terminal Test Module for IBM 1050
\$\$BT1060	Terminal Test Module for IBM 1060
\$\$BT2260	Terminal Test Module for IBM 2260
\$\$BT2740	Terminal Test Module for IBM 2740
\$\$BT2848	Terminal Test Module for 2260, 1053 Remote

Core Image
Phase Names

Test Patterns for On-Line Terminal Tests

IJLBOT02	Transparant EBCDIC Message
IJLBOT03	USASCII Transparency Message
IJLBOT04	Normal EBCDIC Message
IJLBOT05	Normal USASCII Message
IJLBOT06	Alphameric USASCII Message
IJLBOT07	USASCII Printer Message
IJLBOT08	USASCII Punch Message
IJLBOT09	TRANSCODE Printer Message
IJLBOT10	TRANSCODE Punch Message
IJLBOT11	TRANSCODE Multipoint Message
IJLBOT12	EBCDIC Printer Message
IJLBOT13	EBCDIC Punch Message
IJLBOT14	EBCDIC Alphameric Message
IJLBOT15	EBCDIC Weak Pattern Message for Switched Line
IJLBOT16	EBCDIC Weak Pattern Message for Leased Line
IJLBOT17	TRANSCODE Weak Pattern Message for Switched Line
IJLBOT18	TRANSCODE Weak Pattern Message for Leased Line
IJLBOT19	EBCDIC Weak Pattern for OLE SYN Insertion
IJLT2ALC	All Character Test for IBM 2848
IJLT2ROT	Rotate Test for IBM 2848
IJLT2TLT	Tilt Test for IBM 2848

IJLT2TWS	Twist Test for IBM 2848
IJLT3ALC	All Character Test for IBM 1030
IJLT3ROT	Rotate Test for IBM 1030
IJLT3SLA	Analyzer Test for IBM 1030 (Selectric®)
IJLT3TLT	Tilt Test for IBM 1030
IJLT3TWS	Twist Test for IBM 1030
IJLT5ALC	All Character Test for IBM 1050 or 2740
IJLT5ROT	Rotate Test for IBM 1050 or 2740
IJLT5SLA	SELCTRIC Analyzer Test for IBM 1050 or 2740
IJLT5TLT	Tilt Test for IBM 1050 or 2740
IJLT5TWS	Twist Test for IBM 1050 or 2740
IJLT6ALC	All Character Test for IBM 1060
IJLT6ROT	Rotate Test for IBM 1060
IJLT6SLA	SELECTRIC Analyzer Test for IBM 1060
IJLT6TLT	Tilt Test for IBM 1060
IJLT6TWS	Twist Test for IBM 1060

QTAM RELOCATABLE MODULE AND CORE IMAGE PHASE IDENTIFICATION

Relccatable Module Names

IJLQAA	Audio Line Appendage
IJLQAD	IBM 7772 Vocabulary Disk Appendage
IJLQBO	Breakoff (BREAKOFF)
IJLQCK	Checkpoint
IJLQCL	Change Line (STARTLN and STOPLN)
IJLQCM	Cancel message (CANCELM)
IJLQCP	Change Polling list entry (CHNGP)
IJLQCR	Checkpoint Request (CKREQ)
IJLQCT	Change terminal table entry (CHNGT)
IJLQDA	Disk I/O
IJLQDC	Copy Counters (COPYC)
IJLQDE	Copy terminal table entry (COPYT)

IJLQDL	Distribution list
IJLQDP	Copy polling list entry (COPYP)
IJLQDQ	Copy queue control block status (COPYQ)
IJLQDT	Insert date in message header (DATESTMP)
IJLQEA	End-of-address (EOA)
IJLQEB	End-of-block (EOB)
IJLQEC	End-of-block and line correction (EOBLC)
IJLQEP	Normal line appendage and ERP
IJLQER	Error message (ERRMSG)
IJLQEX	Expand message header
IJLQFL	DTF locator
IJLQGA	Get audio message
IJLQGB	Get audio or non-audio message (GET)
IJLQGC	Get audio message or non-audio message record (GET)
IJLQGD	Get audio message or non-audio message segment (GET)
IJLQGM	Get complete message (GET)
IJLQGR	Get message record (GET)
IJLQGS	Get message segment (GET)
IJLQIP	QTAM Implementation
IJLQIT	Intercept message (INTERCPT)
IJLQLA	Line appendage for PCI and program check
IJLQLG	Audio input message logging (LOGSEG)
IJLQLK	Look-up terminal table entry (DIRECT)
IJLQLO	IBM 2260 local appendage
IJLQLP	Time Procedure Specifications Control Routine
IJLQMC	Conversational mode (MODE)
IJLQMI	Initiate mode (MODE)
IJLQMM	Message-mode interface (MODE)
IJLQMP	Priority mode (MODE)
IJLQMT	Compare message type (MSGTYPE)
IJLQMW	Error Recovery Procedures Message Writer Subtask
IJLQMO	Model channel program for IBM 1030 terminals

IJLQM1	Model channel program for IBM 1060 terminals
IJLQM2	Model channel program for IBM 2260 terminals
IJLQM3	Model channel program for AT&T 83B3 terminals
IJLQM4	Model channel program for Western Union Plan 115A terminals
IJLQM5	Model channel program for IBM 1050 switched and nonswitched terminals
IJLQM6	Model channel program for IBM 1050 nonswitched terminals
IJLQM8	Model channel program for AT&T TWX terminals (Models 33 and 35)
IJLQM9	Model channel program for IBM 2260 local terminals
IJLQN0	Model channel program for IBM 2740 Basic terminals
IJLQN1	Model channel program for IBM 2740 Basic Dial terminals
IJLQN2	Model channel program for IBM 2740 terminals with Station Control
IJLQN3	Model channel program for IBM 2740 terminals with Station Control and Checking
IJLQN4	Model channel program for IBM 2740 Dial terminals with Transient Control and Checking
IJLQN5	Model channel program for IBM 2740 terminals with checking
IJLQN6	Model channel program for IBM 2740 Dial terminals with checking
IJLQN7	Model channel program for IBM 2740 Dial terminals with Transmit Control
IJLQN8	Model channel program for World Trade Telegraph Terminals (WTTA)
IJLQOA	Operator Awareness
IJLQOC	Operator Control (OPCTL)
IJLQPA	Put audio message (PUT)
IJLQPL	Polling limit control (POLLIMIT)
IJLQPM	Put complete message (PUT)
IJLQPR	Put message record (PUT)
IJLQPS	Put message segment (PUT)
IJLQPZ	Pause-transmit idle characters (PAUSE)
IJLQQT	Close message control (CLOSEMC)

IJLQRA Translate table RCVARU: ARU code to EBCDIC

IJLQRB Translation table RCVITA2 (EBCDIC to International Telegraph Alphabet No. 2)

IJLQRC Translation table RCVZSC3 (EBCDIC to Figure Protected Code ZSC3)

IJLQRD Retrieve message segment by DASD address (RETRIEVE)

IJLQRG Route message (ROUTE)

IJLQRM Release message (RELEASEM)

IJLQRR Re-route message (REROUTE)

IJLQRS Retrieve message header by sequence number (RETRIEVE)

IJLQRW Physical input/output control

IJLQR1 Translate table RCV1030: 1030 to EBCDIC

IJLQR2 Translate table RCV1050: 1050 to EBCDIC

IJLQR3 Translate table RCV1050F: 1050 to monospace EBCDIC

IJLQR4 Translate table RCV1060: 1060 to EBCDIC

IJLQR5 Translate table RCV2260: 2260 to EBCDIC

IJLQR6 Translate tables RCV83B3 or RCV115A: AT&T 83B3 or WU Plan 115A to EBCDIC

IJLQR7 Translate table RCVTWX: AT&T Models 33/35 (TWX) to EBCDIC

IJLQR8 Translate table RCV2740: 2740 to EBCDIC

IJLQR9 Translate table RCV2740F: 2740 to monospace EBCDIC

IJLQSB Translation table SNDITA2 (International Telegraph Alphabet No. 2 to EBCDIC)

IJLQSC Translation table SNDZSC3 (Figure Protected Code ZSC3 to EBCDIC)

IJLQSH Scan message header

IJLQSI Sequence-in number verification (SEQIN)

IJLQSK Skip-through-character (SKIP)

IJLQSO Insert sequence-out number in message header (SEQOUT)

IJLQSR Source terminal name verification (SOURCE)

IJLQSS Change audio line (STARTARU and STOPARU)

IJLQST Skip-on-count (SKIP)

IJLQS1 Translate table SND1030: EBCDIC to 1030

IJLQS2 Translate table SND1050: EBCDIC to 1050

IJLQS4	Translate table SND1060: EBCDIC to 1060
IJLQS5	Translate table SND2260: EBCDIC to 2260
IJLQS6	Translate tables SND83B3 or SND115A: EBCDIC to AT&T 83B3 or WU Plan 115A
IJLQS7	Translate table SNDTWXE: EBCDIC to AT&T Models 33/35 (TWX) (Even parity)
IJLQS8	Translate table SND2740: EBCDIC to 2740
IJLQS9	Translate table SNDTWXO: EBCDIC to AT&T Models 33/35 (TWX) (non parity)
IJLQTA	World Trade Telegraph Terminals (WTTA) Line Appendage
IJLQTR	Code translation; used in conjunction with QTAM or user-provided translate table (TRANS)
IJLQTS	Insert time-of-day in message header (TIMESTAMP)
IJLQTT	Terminal test recognition (LPSTART)

Transient Phase Names

\$\$BQC01	QTAM	Close Phase 1
\$\$BQC02	QTAM	Close Phase 2
\$\$BQC03	QTAM	Close Phase 3
\$\$BOQ001	QTAM	QTAM Open Monitor/DASD Message Queues-Phase 1
\$\$BOQ002	QTAM	Open Line Group and Main-Storage Process/Destination Queues
\$\$BOQ003	QTAM	Open Checkpoint/Restart-Phase 1
\$\$BOQ004	QTAM	Open Checkpoint/Restart-Phase 2
\$\$BOQ006	QTAM	Open Main Storage Process/Destination Queues
\$\$BOQ007	QTAM	Open IBM 7772 Vocabulary DASD File
\$\$BOQ008	QTAM	Open Audio Line Group and Output Queue
\$\$BQCNCI	QTAM	QTAM Cancel
\$\$BQCNCM	QTAM	QTAM Cancel
\$\$BQHDCK	QTAM	Terminal Test Header Analysis
\$\$BQWTRA	QTAM	ARU Message Writer
\$\$BQWTR1	QTAM	Message Writer-Phase 1
\$\$BQWTR2	QTAM	Message Writer-Phase 2
\$\$BQWTR3	QTAM	Message Writer-Phase 3
\$\$BQ1030	QTAM	Terminal Test Module for IBM 1030

```

$$BQ1050    QTAM    Terminal Test Module for IBM 1050
$$BQ1060    QTAM    Terminal Test Module for IBM 1060
$$BQ2260    QTAM    Terminal Test Module for IBM 2260
$$BQ2740    QTAM    Terminal Test Module for IBM 2740

```

To delete the QTAM phases from the core image library, the QTAM modules from the relocatable library, and the QTAM books from the source statement library, the DELET card for the appropriate library and the name of the phase, module or book to be deleted must be supplied. For example:

```

// JOB DELETE
// EXEC MAINT
  DELETC $$BCQC01,$$BQWTR1,etc.
  DELETR IJLQBO,IJLQCL,IJLQCM,etc.
  DELETS A.BREAKOFF,A.BUFFER,A.CANCELM,etc.
/ε

```

To delete the BTAM phases from the core image library, the BTAM modules from the relocatable library, and the BTAM books from the source statement library, the DELET card for the appropriate library and the name of the phase, module, or book to be deleted must be supplied. For example:

```

// JOB DELETC
// EXEC MAINT
  DELETC $$BCT01,$$BETPRT,etc.
  DELETC IJLT2ALC,IJLT2ROT,etc.
  DELETR IJL00Y,IJL01Z,IJL02Z,etc.
  DELETS A.CONTROL,A.LERB,etc.
/ε

```

To delete both BTAM and QTAM from the core image, relocatable and source statement libraries, the DELET card for the appropriate library and the following entries must be made: For the core image transients, the DELETC card with a separate entry for each transient (QTAM and BTAM) to be deleted must be supplied. For the core image phase names, enter the delete card as follows:

```

DELETC $$BCTC01,$$B00003,$$BETPRT,etc.
DELETC IJLB.ALL
DELETC IJLT.ALL

```

To delete from the relocatable library enter the delete card as follows:

```

DELETR IJL.ALL

```

To delete the BTAM and QTAM books from the source statement library, enter the DELETS card with a separate entry for each book to be deleted. The following example shows the required delete cards and type of entries to be made in those cards.

```

// JOB DELETE
// EXEC MAINT
  DELETS A.CONTROL,A.CANCELM,etc.
/ε

```

On Line Test Executive Program (OLTEP)
Relocatable Module Identification

IJZABOOK
IJZAAOLT
IJZACEOM
IJZACKTP
IJZACMNT
IJZACOMP
IJZACONV
IJZADATA
IJZADEVD
IJZADPRT
IJZAEXIO
IJZAHEAD
IJZAJOPT
IJZAOPEN
IJZAOPTN
IJZAOPUT
IJZARATA
IJZARSLT
IJZATEST
IJZBTIME
IJZAWAIT

Core Image Phase Names

IJZAAOLT
IJZACEOM
IJZACKTP
IJZACMNT
IJZACOMP
IJZACONV
IJZADATA
IJZADEVD
IJZAHEAD
IJZAJOPT
IJZAOPTN
IJZARATA
IJZARSLT
IJZATEST

Transient Phase Name

\$\$BSOPEN
\$\$BZTIME

The linkage editor control statements for cataloging OLTEP into the core image library are:

```
INCLUDE IJZABOOK  
// EXEC INKEDT
```

To delete OLTEP from the core image and relocatable libraries, the following control cards are required:

```
// JOB DELETE  
// EXEC MAINT  
  DELETC $$BSOPEN  
  DELETC $$BZTIME  
  DELETC IJZA.ALL  
  DELETR IJZ.ALL  
/E
```

PREASSEMBLED MODULES USED TO BUILD IBM COMPONENTS

Module
Name

IJGWEZZZ
 IJFWEZZZ
 IJFWZNZZ
 IJFWZZZZ
 IJGWZNZZ
 IJGWZRZZ
 IJJCPDV
 IJJCPDV1
 IJJCPDV2
 IJJCPD0
 IJJCPD0N
 IJJCPD1
 IJJCPD1N
 IJJCPD2
 IJJCPD3
 IJJCPV
 IJJCPV1
 IJJCPV2
 IJJCP0
 IJJCP0N
 IJJCP1
 IJJCP1N
 IJJCP2
 IJJCP3
 IJJFCBID
 IJJFCBZD
 IJJFCIID
 IJJFCIZD

SOURCE STATEMENT LIBRARY MACROS

The following are the names of the macro definitions in the source statement library of the IBM supplied systems residence volume.

	<u>Supervisor Generation</u>	<u>File Definition</u>	<u>Supervisor Communications</u>	<u>IOCS Imperatives</u>	<u>Misc. Macros</u>
A.ALLOC	x				
A.ARUMGTYP					Q
A.ASMTRTAB					B
A.ASSGN	x				
A.ATTACH			x		
A.BREAKOFF					Q
A.BTMOD					B
A.BTRWC					B
A.BTWAIT					B
A.BUFARU					Q
A.BUFFER					Q
A.CALL			x		
A.CANCEL			x		
A.CANCELM					Q
A.CCB				x	
A.CDMOD		x			
A.CHECK				MT,SD,MR	
A.CHECKARU					Q
A.CHGNTRY					B
A.CHKPT			x		

	<u>Supervisor Generation</u>	<u>File Definition</u>	<u>Supervisor Communications</u>	<u>IOCS Imperatives</u>	<u>Misc. Macros</u>
A.CHNG			8k		
A.CHNGP					Q
A.CHNGT					Q
A.CKREQ					Q
A.CLOSE				x	
A.CIOSEMC					Q
A.CLOSER				x	
A.CNTRL				x	
A.CMMN	x				
A.COMRG			x		
A.CONFIG	x				
A.CONTROL				B	
A.COPYC					Q
A.COPYP					Q
A.COPYQ					Q
A.COPYT					Q
A.COUNTER					Q
A.CTLTBL					Q
A.DAMOD		x			
A.DATESTMP					Q
A.DEQ			x		
A.DETACH			x		
A.DFTRMLST					B
A.DIAG					E
A.DIMOD		x			
A.DIRECT					Q
A.DISEN					MR
A.DOSCHLV					M
A.DSPLY				x	
A.DTFBG		8k			
A.DTFBT					B
A.DTFBTND					B
A.DTFCD		x			
A.DTFCN		x			
A.DTFDA		x			
A.DTFDI		x			
A.DTFEN		8k			
A.DTFIS		x			
A.DTFIS1		x			
A.DTFIS2		x			
A.DTFIS3		x			
A.DTFMR		x			
A.DTFMT		x			
A.DTFOR		x			
A.DTFPH		x			
A.DTFPR		x			
A.DTFPT		x			
A.DTFQT					Q
A.DTFSD		x			
A.DTFSR		8k			
A.DUMP			x		
A.DVCGEN	x				
A.ENDFL				IS	
A.ENDRCV					Q
A.ENDREADY					Q
A.ENDSEND					Q
A.ENQ			x		
A.EOA					Q
A.EOB					Q
A.EOBLC					Q
A.ECJ			x		

	<u>Supervisor Generation</u>	<u>File Definition</u>	<u>Supervisor Communications</u>	<u>IOCS Imperatives</u>	<u>Misc. Macros</u>
A. ERET				x	
A. ERRMSG					Q
A. ESETL				IS	
A. EU3 CG					E
A. EU3 DK					E
A. EU3 EJ					E
A. EU3 ER					E
A. EU3 FT					E
A. EU3 MS					E
A. EU3 OS					E
A. EU3 PH					E
A. EU3 PT					E
A. EU3 RD					E
A. EU3 TP					E
A. EU3 0					E
A. EU4 CG					E
A. EU4 DK					E
A. EU4 EJ					E
A. EU4 ER					E
A. EU4 FT					E
A. EU4 IN					E
A. EU4 MS					E
A. EU4 OS					E
A. EU4 PH					E
A. EU4 PT					E
A. EU4 RD					E
A. EU4 TP					E
A. EU4 0					E
A. EXCP				x	
A. EXIT			x		
A. FEOV				MT,SR	
A. FETCH			x		
A. FOPT	x				
A. FREE				x	
A. GET				x	
A. GETIME			x		
A. IJK ZL					I
A. IJLBTMDS					B
A. IJLQBABD					Q
A. IJLQBFRD	Q				
A. IJLQBRBD					Q
A. IJLQCKPD					Q
A. IJLQCTLD					Q
A. IJLQDEQU					Q
A. IJLQDSCT	Q				
A. IJLQDTFD					Q
A. IJLQIP1D	Q				
A. IJLQLABD					Q
A. IJLQLCBD					Q
A. IJLQMCBD					Q
A. IJLQQCBD	Q				
A. IJLQSTBD	Q				
A. IJLQSVCD					Q
A. IJLQTBLD					Q
A. IJLQTSVC	Q				
A. IJLQVECD	Q				
A. INCARD					U
A. INDISK					U
A. INLOG					U
A. INTAPE					U
A. INTCR					U
A. INTERCPT					Q

	<u>Supervisor Generation</u>	<u>File Definition</u>	<u>Supervisor Communications</u>	<u>IOCS Imperatives</u>	<u>Misc. Macros</u>
A.IOTAB	x				
A.ISMOD		X			
A.ISMOD0		x			
A.ISMOD1		x			
A.ISMOD2		x			
A.ISMOD3		x			
A.ISMOD4		x			
A.ISMOD5		x			
A.ISMOD6		x			
A.ISMOD7		x			
A.ISMOD8		x			
A.ISMOD9		x			
A.LBRET			x		
A.LCBD					Q
A.LERB					B
A.LERPRT					B
A.LINE					Q
A.LINETBL					Q
A.LIST					Q
A.LITE					MR
A.LOAD			x		
A.LOADA					C
A.LODIS					C, P
A.LOGSEG					Q
A.LOPEN					B
A.LPSTART					Q
A.LUBGEN	x				Q
A.MODE					Q
A.MRMOD		x			
A.MSGTYPE					Q
A.MTMOD		x			
A.MVCOM			x		
A.NOTE				MT, SR	
A.ONLTST					B
A.OPCTL					Q
A.OPEN				x	
A.OPENR				x	
A.OPTION					Q
A.ORMOD		x			
A.OTAPE					U
A.OUTCARD					U
A.OUTDISK					U
A.OUTLOG					U
A.OUTPUT					U
A.PAUSE					Q
A.PDUMP			x		
A.PIOCS	x				
A.POINTR				MT, SD	
A.POINTS				MT, SD	

<u>Supervisor Generation</u>	<u>File Definition</u>	<u>Supervisor Communications</u>	<u>IOCS Imperative</u>	<u>Misc. Macros</u>
A.POINTW			MT,SD	
A.POLL				Q
A.POLLIMIT				Q
A.POST		x		
A.POSTARU				Q
A.POSTRCV				Q
A.POSTSEND				Q
A.PREFIXD				Q
A.PRMOD	x			
A.PROCESS				Q
A.PRTOV			PR	
A.PTMOD	x			
A.PUT			x	
A.QCBD				Q
A.RANDA				C
A.RCB		x		
A.RCVHDR				Q
A.RCVITA2				Q
A.RCVSEG				Q
A.RCVZSC3				Q
A.RILNE			x	
A.READ			MT,SD,IS,DA,B,MR	
A.RELBUF				B
A.RELEASEM				Q
A.RELSE			MT,SD,SR	
A.REPEAT				Q
A.REQBUF				B
A.REROUTE				Q
A.RESCN			x	
A.RESETPL				B
A.RETRIEVE				Q
A.RETURN		x		
A.ROUTE				Q
A.RRUIS				C
A.RUADA				C,P
A.RUAIS				C,P
A.SAVE		x		
A.SDMOD	x			
A.SDMODFI	x			
A.SDMODFO	x			
A.SDMODFU	x			
A.SDMODUI	x			
A.SDMODUO	x			
A.SDMODUU	x			
A.SDMODVI	x			
A.SDMODVO	x			
A.SDMODVU	x			

	<u>Supervisor Generation</u>	<u>File Definition</u>	<u>Supervisor Communications</u>	<u>IOCS Imperative</u>	<u>Misc. Macros</u>
A.SIMODW		x			
A.SEND	x				
A.SENDHDR					Q
A.SENDSEG					Q
A.SEOV				x	
A.SEQDA					C
A.SEQIN					Q
A.SEQOUT					Q
A.SETFL				IS	
A.SETIME			x		
A.SETL	.			IS	
A.SGDFCH	x				
A.SGDSK	x				
A.SGSVC	x				
A.SGTCHS	x				
A.SGTCON	x				
A.SGT HAP	x				
A.SGUNCK	x				
A.SKIP					Q
A.SMICR	MR				
A.SNDITA2					Q
A.SNDZSC3					Q
A.SOURCE					Q
A.SRU IS					C
A.STARTARU					Q
A.STARTLN					Q
A.STCBD					Q
A.STDJC	x				
A.STOPARU					Q
A.STOPLN					Q
A.STXIT			x		
A.SUPVR	x				
A.TECB			x		
A.TERM					Q
A.TERM TBL					Q
A.TERM TBLD					Q
A.TIMESTMP					Q
A.TRANS					Q
A.TRN SLATE					B
A.TRS RCTW					B
A.TRSRCT3					B
A.TRS SCTW					B
A.TRS SCT3					B
A.TRUNC				MT,SD,SR	
A.TWAIT					B
A.WAIT			x		
A.WAITF				IS,DA,MR	
A.WAITM			x		

<u>Supervisor Generation</u>	<u>File Definition</u>	<u>Supervisor Communications</u>	<u>IOCS Imperative</u>	<u>Misc. Macros</u>
A. WORD				Q
A. WORDTBL				Q
A. WRI TE			MT, SD, IS, DA, B	
A. WRU				Q
Z. AS1				S
Z. AS2				S
Z. AS3				S
Z. AS4				S
Z. AS5				S
Z. AS6				S
Z. AT1				S
Z. CB1				S
Z. DELETECL				D
Z. DELETERL				D
Z. DELETESL				D
Z. EU3 SPRGM				S
Z. EU4 SPRGM				S
Z. FO1				S
Z. ILFMERGE				F
Z. ILFSAMPL				S
Z. LINKEDIT				L
Z. MCR1				S
Z. MCR2				S
Z. ORDC				S
Z. ORJT				S
Z. PL1				S
Z. RG1				S
Z. SM1				S
Z. SM2				S
Z. SM4				S
Z. SM5				S
Z. SM6				S
Z. UTDCPR1				S
Z. UTDKPR1				S
Z. UTDKPR2				S
Z. UTDKPR3				S
Z. UTTPPR1				S
Z. UTTPPR2				S
Z. VFU1				S

Key: x generally applicable
 B BTAM
 C COBOL DASD macros (these macros are not necessary for COBOL compilation or execution)
 D Delete book
 E emulator macro
 F Basic FORTRAN Compatability with FORTRAN
 I PL/I macro
 L Linkage edit book
 M display change level book
 P PL/I DASD macros
 Q QTAM
 S* sample problem
 U utility macros
 MR magnetic character readers
 MT magnetic tape
 SD sequential DASD
 IS index sequential
 DA direct access
 SR serial
 PR printer
 8k for BPS and BOS compatibility

* for 1285 sample problem change DEVICE on the cards with the sequence numbers 1054 and 1070 from DEVICE=1287 to DEVICE=1285

Appendix D. Disk Sort/Merge Modules

The Disk Sort/Merge program residing in the relocatable library consists of three entries:

1. primary processor generation modules
2. intermediate processor generation modules
3. relocatable object modules.

These modules enable a user to linkage edit into the core image library only those modules required to tailor a generalized sort/merge program to specific job applications. At system generation time, the user can linkage edit any one of seven distinct sort/merge object programs into the core image library.

The following programs can be generated at linkage edit time:

1. The entire sort/merge program.
2. A program that
 - a. sorts fixed-length records;
 - b. performs the ADDROUT option for fixed or variable-length record; and
 - c. merges fixed or variable-length records.
3. A program that
 - a. sorts variable-length records;
 - b. performs the ADDROUT option for fixed or variable-length records; and
 - c. merges fixed or variable-length records.
4. A program that
 - a. sorts fixed or variable-length records; and
 - b. performs the ADDROUT option for fixed or variable-length records.
5. A program that
 - a. sorts fixed-length records; and
 - b. performs the ADDROUT option for fixed or variable-length records.

6. A program that
 - a. sorts variable-length records; and
 - b. performs the ADDR0UT option for fixed or variable-length records.
7. A program that merges fixed or variable-length records.

The user should linkage edit only the Sort/Merge program that satisfies his particular requirements. To generate:

```

Program 1. specify:  INCLUDE IJOSM
                   // EXEC LNKEDT

Program 2. specify:  INCLUDE IJOSMFOM
                   // EXEC LNKEDT

Program 3. specify:  INCLUDE IJOSMVOM
                   // EXEC LNKEDT

Program 4. specify:  INCLUDE IJOSMFVS
                   // EXEC LNKEDT

Program 5. specify:  INCLUDE IJOSMFOS
                   // EXEC LNKEDT

Program 6. specify:  INCLUDE IJOSMVOS
                   // EXEC LNKEDT

Program 7. specify:  INCLUDE IJOSMERG
                   // EXEC LNKEDT

```

Primary Processor Generation Books

CATALR IJOSM

```

INCLUDE IJOSMPH0
INCLUDE IJOSMPH1
INCLUDE IJOSMF23
INCLUDE IJOSMV23
INCLUDE IJOSMPH4
END

```

Entire Sort/Merge program.

CATALR IJOSMFOM

```

INCLUDE IJOSMPH0
INCLUDE IJOSMPH1
INCLUDE IJOSMF23
INCLUDE IJOSMPH4
END

```

1. Sort program for fixed-length records.
2. ADDR0UT option (fixed or variable).
3. Merge-only for fixed or variable-length records.

CATALR IJOSMVOM

INCLUDE IJOSMPH0 1. Sort program for variable-length records.
 INCLUDE IJOSMPH1 2. ADDROUT option (fixed or variable).
 INCLUDE IJOSMV23 3. Merge-only for fixed or variable-length records.

INCLUDE IJOSMPH4
 END

CATALR IJOSMFVS

INCLUDE IJOSMPH0 1. Sort program for fixed or variable-length records.
 INCLUDE IJOSMPH1 2. ADDROUT option (fixed or variable).
 INCLUDE IJOSMF23
 INCLUDE IJOSMV23
 END

CATALR IJOSMFOS

INCLUDE IJOSMPH0 1. Sort program for fixed-length records.
 INCLUDE IJOSMPH1 2. ADDROUT option (fixed or variable).
 INCLUDE IJOSMF23
 END

CATALR IJOSMVOS

INCLUDE IJOSMPH0 1. Sort program for variable-length records.
 INCLUDE IJOSMPH1 2. ADDROUT option (fixed or variable).
 INCLUDE IJOSMV23
 END

CATALR IJOSMERG

INCLUDE IJOSMPH0 1. Merge-only program for fixed or variable-length records.
 INCLUDE IJOSMPH4
 END

Intermediate Processor Generation Books

CATALR IJOSMPH0

PHASE DSORT
 INCLUDE IJOSM001
 PHASE DSORT002
 INCLUDE IJOSM002
 PHASE DSORT003
 INCLUDE IJOSM003
 PHASE DSORT004
 INCLUDE IJOSM004
 PHASE DSORT005
 INCLUDE IJOSM005
 PHASE DSORT006
 INCLUDE IJOSM006
 PHASE DSORT007
 INCLUDE IJOSM007
 PHASE DSORT008
 INCLUDE IJOSM008
 PHASE DSORT009

INCLUDE IJOSM009
PHASE DSORT010
INCLUDE IJOSM010
END

CATALR IJOSMV23

PHASE DSORT203
INCLUDE IJOSM203
PHASE DSORT204
INCLUDE IJOSM204
PHASE DSORT303
INCLUDE IJOSM303
PHASE DSORT304
INCLUDE IJOSM304
END

CATALR IJOSMERG

PHASE DSORT401
INCLUDE IJOSM401
PHASE DSORT402
INCLUDE IJOSM402
END

CATALR IJOSMPH1

PHASE DSORT101
INCLUDE IJOSM101
PHASE DSORT102
INCLUDE IJOSM102

PHASE DSORT103
INCLUDE IJOSM103
PHASE DSORT104
INCLUDE IJOSM104
PHASE DSORT105
INCLUDE IJOSM105
END

1. IJOSMPH0 = Assignment Phase.
2. IJOSMPH1 = Phase 1.
3. IJOSMF23 = Phases 2-3 for fixed-length records.
4. IJOSMV23 = Phase 2-3 for variable-length records.
5. IJOSMPH4 = Merge-only or Phase 4.

CATALR IJOSMF23

PHASE DSORT201
INCLUDE IJOSM201
PHASE DSORT202
INCLUDE IJOSM202
PHASE DSORT301
INCLUDE IJOSM301
PHASE DSORT302
INCLUDE IJOSM302
PHASE DSORT501
INCLUDE IJOSM501
END

Phase Names and Relocatable Module Names

<u>Phase Name</u>	<u>Csect Name</u>	<u>Module Name</u>	<u>Required</u>	<u>Program Phase</u>
DSORT	IJO00110	IJOSM001		
DSORT002	IJO00210	IJOSM002		
DSORT003	IJO00310	IJOSM003		
DSORT004	IJO00410	IJOSM004		
DSORT005	IJO00510	IJOSM005	Always	Assignment
DSORT006	IJO00610	IJOSM006	required	Phase
DSORT007	IJO00710	IJOSM007		(Phase 0)
DSORT008	IJO00810	IJOSM008		
DSORT009	IJO00910	IJOSM009		
DSORT010	IJO01010	IJOSM010		
DSORT101	IJO10110	IJOSM101		
DSORT102	IJO10210	IJOSM102	Required	
DSORT103	IJO10310	IJOSM103	for	Phase 1
DSORT104	IJO10410	IJOSM104	Sort	
DSORT105	IJO10510	IJOSM105		
DSORT201	IJO20110	IJOSM201	Fixed-length	
DSORT202	IJO20210	IJOSM202	records: SORT	Phase 2
DSORT203	IJO20310	IJOSM203	Variable-length	
DSORT204	IJO20410	IJOSM204	records: Sort	
DSORT301	IJO30110	IJOSM301	Fixed-length	
DSORT302	IJO30210	IJOSM302	records: Sort	Phase 3
DSORT303	IJO30310	IJOSM303	Variable-length	
DSORT304	IJO30410	IJOSM304	records: Sort	
DSORT401	IJO40110	IJOSM401	Merge-only	Phase 4
DSORT402	IJO40210	IJOSM402	operations	(Merge)

Appendix E. Tape and Disk Sort/Merge Modules

The Tape and Disk Sort/Merge program residing in the relocatable library consists of three entries:

- primary processor generation modules
- intermediate processor generation modules
- relocatable object modules.

These modules enable a user to linkage edit into the core image library only those modules required to tailor a generalized sort/merge program to specific job applications. At system generation time, the user can linkage edit any one of six distinct sort/merge object programs into the core image library:

1. The entire sort/merge program.
2. The entire sort program.
3. The merge program.
4. A sort program that uses 2400 tape units as intermediate storage.
5. A sort program that uses 2311 direct access devices as intermediate storage.
6. A sort program that uses 2314 direct access devices as intermediate storage.

To conserve library space, the user should linkage edit only the sort/merge program that satisfies his particular requirements. Note that an attempt to execute an option not selected will result in abnormal termination of the sort/merge program. To generate:

```
Program 1. specify:  INCLUDE ILHSALL
                   // EXEC LNKEDT

Program 2. specify:  INCLUDE ILHSORT
                   // EXEC LNKEDT

Program 3. specify:  INCLUDE ILHSMRG
                   // EXEC LNKEDT

Program 4. specify:  INCLUDE ILHST
                   // EXEC LNKEDT

Program 5. specify:  INCLUDE ILHSD1
                   // EXEC LNKEDT

Program 6. specify:  INCLUDE ILHSD4
                   // EXEC LNKEDT
```

If the sort/merge program is generated in a system without multiprogramming support, the following primary processor generation module must be linkage edited immediately after the selected program: .

```
INCLUDE ILHNMPS
// EXEC LNKEDT
```

Primary Processor Generation Books

```
CATALR      ILHSALL
INCLUDE      ILHSPH0
INCLUDE      ILHSPH1
INCLUDE      ILHSPH2   Entire Sort/Merge Program
INCLUDE      ILHSPH3
END

CATALR      ILHSORT
INCLUDE      ILHSPH0S
INCLUDE      ILHSPH1
INCLUDE      ILHSPH2   Entire Sort Program
INCLUDE      ILHSPH3S
END

CATALR      ILHSMRG
INCLUDE      ILHSPH0M
INCLUDE      ILHSPH3M   Merge Program
END

CATALR      ILHST
INCLUDE      ILHSPH0T
INCLUDE      ILHSPH1T
INCLUDE      ILHSPH2T   2400 Sort Program
INCLUDE      ILHSPH3T
END

CATALR      ILHSD1
INCLUDE      ILHSPH01
INCLUDE      ILHSPH11
INCLUDE      ILHSPH21   2311 Sort Program
INCLUDE      ILHSPH31
END

CATALR      ILHSD4
INCLUDE      ILHSPH04
INCLUDE      ILHSPH14
INCLUDE      ILHSPH24   2314 Sort Program
INCLUDE      ILHSPH34
END

CATALR      ILHSNMPS
INCLUDE      ILHSPHN   Required for systems without multiprogramming
                        support
```

Intermediate Processor Generation Books

```
CATALR      ILHSPH0
PHASE        SORT,+0
INCLUDE      ILHSPPI
INCLUDE      ILHSRTMG
PHASE        SORTRCL,*
```

```

INCLUDE  ILHSRCI
INCLUDE  ILHSRCA
INCLUDE  ILHSRCM      Entire Sort/Merge Program
PHASE    SORTRCB,*    Phase 0
INCLUDE  ILHSRCB
INCLUDE  ILHSRCJ
INCLUDE  ILHSRCI
PHASE    SORTRCK,*
INCLUDE  ILHSRCK
PHASE    SORTRCC,*
INCLUDE  ILHSRCC
PHASE    SORTRCD,*
INCLUDE  ILHSRCD
PHASE    SORTRCE,*
INCLUDE  ILHSRCE
PHASE    SORTRCF,*
INCLUDE  ILHSRCF
PHASE    SORTRCH,*
INCLUDE  ILHSRCH
END

```

CATALR ILHSPHOS

```

PHASE    SORT,+0
INCLUDE  ILHSPP1
INCLUDE  ILHSRTMG
PHASE    SORTRCL,*
INCLUDE  ILHSRCI
INCLUDE  ILHSRCA
INCLUDE  ILHSRCM
PHASE    SORTRCB,*    Entire Sort Program
INCLUDE  ILHSRCB      Phase 0
INCLUDE  ILHSRCJ
INCLUDE  ILHSRCI
PHASE    SORTRCK,*
INCLUDE  ILHSRCK
PHASE    SORTRCC,*
INCLUDE  ILHSRCC
PHASE    SORTRCD,*
INCLUDE  ILHSRCD
PHASE    SORTRCE,*
INCLUDE  ILHSRCE
PHASE    SORTRCF,*
INCLUDE  ILHSRCF
END

```

CATALR ILHSPHOM

```

PHASE    SORT,+0
INCLUDE  ILHSPP1
INCLUDE  ILHSRTMG
PHASE    SORTRCL,*
INCLUDE  ILHSRCL
INCLUDE  ILHSRCA      Merge Program
INCLUDE  ILHSRCM      Phase 0
PHASE    SORTRCB,*
INCLUDE  ILHSRCB
PHASE    SORTRCJ,*
INCLUDE  ILHSRCJ
INCLUDE  ILHSRCI
PHASE    SORTRCK,*
INCLUDE  ILHSRCK
PHASE    SORTRCC,*
INCLUDE  ILHSRCC
PHASE    SORTRCD,*
INCLUDE  ILHSRCD

```

CATALR ILHSPH0M
PHASE SORTRCH,*
INCLUDE ILHSRCH
END

CATALR ILHSPH0T

PHASE SORT,+0
INCLUDE ILHSPPI
INCLUDE ILHSRTMG
PHASE SORTRCL,*
INCLUDE ILHSRCL
INCLUDE ILHSRCA
INCLUDE ILHSRCM
PHASE SORTRCB,* 2400 Sort Program
INCLUDE ILHSRCB Phase 0
PHASE SORTRCJ,*
INCLUDE ILHSRCJ
INCLUDE ILHSRCI
PHASE SORTRCK,*
INCLUDE ILHSRCK
PHASE SORTRCC,*
INCLUDE ILHSRCC
PHASE SORTRCD,*
INCLUDE ILHSRCD
PHASE SORTRCE,*
INCLUDE ILHSRCE
END

CATALR ILHSPH01

PHASE SORT,+0
INCLUDE ILHSPPI
INCLUDE ILHSRTMG
PHASE SORTRCL,*
INCLUDE ILHSRCL
INCLUDE ILHSRCA
INCLUDE ILHSRCM
PHASE SORTRCB,* 2311 Sort Program
INCLUDE ILHSRCB Phase 0
PHASE SORTRCJ,*
INCLUDE ILHSRCJ
INCLUDE ILHSRCI
PHASE SORTRCK,*
INCLUDE ILHSRCK
PHASE SORTRCC,*
INCLUDE ILHSRCC
PHASE SORTRCD,*
INCLUDE ILHSRCD
PHASE SORTRCF,*
INCLUDE ILHSRCF
END

CATALR ILHSPH04

PHASE SORT,+0
 INCLUDE ILHSPP I
 INCLUDE ILHSRTMG
 PHASE SORTRCL,*
 INCLUDE ILHSRCL
 INCLUDE ILHSRCA
 INCLUDE ILHSRCM
 PHASE SORTRCB,* 2314 Sort Program
 INCLUDE ILHSRCB Phase 0
 PHASE SORTRCJ,*
 INCLUDE ILHSRCJ
 INCLUDE ILHSRCI
 PHASE SORTRCK,*
 INCLUDE ILHSRCK
 PHASE SORTRCC,*
 INCLUDE ILHSRCC
 PHASE SORTRCD,*
 INCLUDE ILHSRCD
 PHASE SORTRCF,*
 INCLUDE ILHSRCF
 END

CATALR ILHSPHN

PHASE SORT,* Also required for Phase 0 of all
 INCLUDE ILHSPP I sort/merge programs in systems
 INCLUDE ILHSRTMG without multiprogramming support

CATALR ILHSPH1

PHASE SORTRCN,*
 INCLUDE ILHSRCN
 PHASE SORTRSD,*
 INCLUDE ILHSRSD
 PHASE SORTRSE,*
 INCLUDE ILHSRSI
 INCLUDE ILHSRSE
 INCLUDE ILHSRMC
 PHASE SORTASA,* Entire Sort Program
 INCLUDE ILHSASA Phase 1
 PHASE SORTROA,*
 INCLUDE ILHSROA
 PHASE SORTRDA,*
 INCLUDE ILHSRDA
 PHASE SORTRDB,*
 INCLUDE ILHSRDB
 PHASE SORTRDC,*
 INCLUDE ILHSRDC
 PHASE SORTRAA,*
 INCLUDE ILHSRAA
 PHASE SORTRAB,*
 INCLUDE ILHSRAB
 PHASE SORTRBA,*
 INCLUDE ILHSRBA
 PHASE SORTRBB,*
 INCLUDE ILHSRBB
 PHASE SORTRBC,*
 INCLUDE ILHSRBC
 PHASE SORTRBD,*
 INCLUDE ILHSRBD
 PHASE SORTRGA,*
 INCLUDE ILHSRGA
 PHASE SORTRGB,*

```

INCLUDE ILHSRGP
PHASE SORTRPA,*
INCLUDE ILHSRPA
PHASE SORTRPB,*
INCLUDE ILHSRPB
END

```

CATALR ILHSPH1T

```

PHASE SORTRCN,*
INCLUDE ILHSRCN
PHASE SORTRSD,*
INCLUDE ILHSRSD
PHASE SORTRSE,*
INCLUDE ILHSRSI
INCLUDE ILHSRSE
INCLUDE ILHSRMC
PHASE SORTASA,*
INCLUDE ILHSASA
PHASE SORTROA,*
INCLUDE ILHSROA      2400 Sort Program
PHASE SORTRDA,*      Phase 1
INCLUDE ILHSRDA
PHASE SORTRDB,*
INCLUDE ILHSRDB
PHASE SORTRAA,*
INCLUDE ILHSRAA
PHASE SORTRBA,*
INCLUDE ILHSRBA
PHASE SORTRBB,*
INCLUDE ILHSRBB
PHASE SORTRBD,*
INCLUDE ILHSRBD
PHASE SORTRGA,*
INCLUDE ILHSRGA
PHASE SORTRGB,*
INCLUDE ILHSRGP
PHASE SORTRPA,*
INCLUDE ILHSRPA
END

```

CATALR ILHSPH11

```

PHASE SORTRCN,*
INCLUDE ILHSRCN
PHASE SORTRSD,*
INCLUDE ILHSRSD
PHASE SORTRSE,*
INCLUDE ILHSRSI
INCLUDE ILHSRSE
INCLUDE ILHSRMC
PHASE SORTASA,*
INCLUDE ILHSASA
PHASE SORTROA,*      2311 Sort Program
INCLUDE ILHSROA      Phase 1
PHASE SORTRDA,*
INCLUDE ILHSRDA
PHASE SORTRDB,*
INCLUDE ILHSRDB
PHASE SORTRDC,*
INCLUDE ILHSRDC
PHASE SORTRAB,*
INCLUDE ILHSRAB
PHASE SORTRBA,*
INCLUDE ILHSRBA

```

```

CATALR    ILHPH11
PHASE      SORTRBC,*
INCLUDE    ILHSRBC
PHASE      SORTRBD,*
INCLUDE    ILHSRBD
PHASE      SORTRGA,*
INCLUDE    ILHSRGA
PHASE      SORTRGB,*
INCLUDE    ILHSRGB
PHASE      SORTRPB,*
INCLUDE    ILHSRPB
END

```

```

CATALR    ILHSPH14

```

```

PHASE      SORTRCN,*
INCLUDE    ILHSRCN
PHASE      SORTRSD,*
INCLUDE    ILHSRSD
PHASE      SORTRSE,*
INCLUDE    ILHSRSI
INCLUDE    ILHSRSE
INCLUDE    ILHSRMC
PHASE      SORTASA,*
INCLUDE    ILHSASA
PHASE      SORTROA,*
INCLUDE    ILHSROA    2314 Sort Program
PHASE      SORTRDA,*  Phase 1
INCLUDE    ILHSRDA
PHASE      SORTRDB,*
INCLUDE    ILHSRDB
PHASE      SORTRDC,*
INCLUDE    ILHSRDC
PHASE      SORTRAB,*
INCLUDE    ILHSRAB
PHASE      SORTRBA,*
INCLUDE    ILHSRBA
PHASE      SORTRBC,*
INCLUDE    ILHSRBC
PHASE      SORTRBD,*
INCLUDE    ILHSRBD
PHASE      SORTRGA,*
INCLUDE    ILHSRGA
PHASE      SORTRGB,*
INCLUDE    ILHSRGB
PHASE      SORTRPB,*
INCLUDE    ILHSRPB
END

```

```

CATALR    ILHSPH2

```

```

PHASE      SORTRSG,*
INCLUDE    ILHSRSG
PHASE      SORTRSH,*
INCLUDE    ILHSRSH
PHASE      SORTRSJ,*
INCLUDE    ILHSRSM
INCLUDE    ILHSRSJ
INCLUDE    ILHSRMC
PHASE      SORTRAC,*
INCLUDE    ILHSRAC
INCLUDE    ILHSRGD
INCLUDE    ILHSRPC    Entire Sort Program
INCLUDE    ILHSAAC    Phase 2
INCLUDE    ILHSASG

```

```

INCLUDE ILHSAPC
INCLUDE ILHSAGD
PHASE SORTRAD,*
INCLUDE ILHSRAD
INCLUDE ILHSRGE
INCLUDE ILHSRPD
INCLUDE ILHSAAD
INCLUDE ILHSASG
INCLUDE ILHSAPD
INCLUDE ILHSAGE
PHASE SORTROB,*
INCLUDE ILHSROB
INCLUDE ILHSRBF
INCLUDE ILHSASF
INCLUDE ILHSAOB
INCLUDE ILHSABF
END

```

CATALR ILHSPH2T

```

PHASE SORTRSG,*
INCLUDE ILHSRSG
PHASE SORTRSH,*
INCLUDE ILHSRSH
PHASE SORTRSJ,*
INCLUDE ILHSRSM
INCLUDE ILHSRSJ      2400 Sort Program
INCLUDE ILHSRMC      Phase 2
PHASE SORTRAC,*
INCLUDE ILHSRAC
INCLUDE ILHSRGD
INCLUDE ILHSRPC
INCLUDE ILHSAAC
INCLUDE ILHSASG
INCLUDE ILHSAPC
INCLUDE ILHSAGD
PHASE SORTROB,*
INCLUDE ILHSROB
INCLUDE ILHSRBF
INCLUDE ILHSASF
INCLUDE ILHSAOB
INCLUDE ILHSABF
END

```

CATALR ILHSPH21

```

PHASE SORTRSG,*
INCLUDE ILHSRSG
PHASE SORTRSH,*
INCLUDE ILHSRSH
PHASE SORTRSJ,*
INCLUDE ILHSRSM
INCLUDE ILHSRSJ
INCLUDE ILHSRMC
PHASE SORTRAD,*      2311 Sort Program
INCLUDE ILHSRAD      Phase 2
INCLUDE ILHSRGE
INCLUDE ILHSRPD
INCLUDE ILHSAAD
INCLUDE ILHSASG
INCLUDE ILHSAPD
INCLUDE ILHSAGE
PHASE SORTROB,*
INCLUDE ILHSROB

```

CATALR ILHSPH21
INCLUDE ILHSRBF
INCLUDE ILHSASF
INCLUDE ILHSAOB
INCLUDE ILHSABF
END

CATALR ILHSPH24

PHASE SORTRSG,*
INCLUDE ILHSRSG
PHASE SORTRSH,*
INCLUDE ILHSRSH
PHASE SORTRSJ,*
INCLUDE ILHSRSM
INCLUDE ILHSRSJ
INCLUDE ILHSRMC 2314 Sort Program
PHASE SORTRAD,* Phase 2
INCLUDE ILHSRAD
INCLUDE ILHSRGE
INCLUDE ILHSRPD
INCLUDE ILHSAAD
INCLUDE ILHSASG
INCLUDE ILHSAPD
INCLUDE ILHSAGE
PHASE SORTROB,*
INCLUDE ILHSROB
INCLUDE ILHSRBF
INCLUDE ILHSASF
INCLUDE ILHSAOB
INCLUDE ILHSABF
END

CATALR ILHSPH3

PHASE SORTRSM,*
INCLUDE ILHSRSM
INCLUDE ILHSRSE
INCLUDE ILHSRMC
PHASE SORTRSN,*
INCLUDE ILHSRSN
INCLUDE ILHSRMC
PHASE SORTROC,*
INCLUDE ILHSROC
INCLUDE ILHSRBG Entire Sort/Merge Program
INCLUDE ILHSRPE Phase 3
INCLUDE ILHSAOC
INCLUDE ILHSABG
INCLUDE ILHSASK
INCLUDE ILHSASL
PHASE SORTRGH,*
INCLUDE ILHSRGH
INCLUDE ILHSAGH
INCLUDE ILHSAPH
PHASE SORTRGF,*
INCLUDE ILHSRGF
INCLUDE ILHSAGF
INCLUDE ILHSAPF
PHASE SORTRGG,*
INCLUDE ILHSRGG
INCLUDE ILHSAGG
INCLUDE ILHSAPG
END

CATALR ILHSPH3S

```
PHASE      SORTRSM,*
INCLUDE    ILHSRSM
INCLUDE    ILHSRSE
INCLUDE    ILHSRMC
PHASE      SORTRSN,*
INCLUDE    ILHSRSN
INCLUDE    ILHSRMC
PHASE      SORTROC,*
INCLUDE    ILHSROC      Entire Sort Program
INCLUDE    ILHSRBG      Phase 3
INCLUDE    ILHSRPE
INCLUDE    ILHSAOC
INCLUDE    ILHSABG
INCLUDE    ILHSASK
INCLUDE    ILHSASL
PHASE      SORTRGF,*
INCLUDE    ILHSRGF
INCLUDE    ILHSAGF
INCLUDE    ILHSAPF
PHASE      SORTRGG,*
INCLUDE    ILHSRGG
INCLUDE    ILHSAGG
INCLUDE    ILHSAPG
END
```

CATALR ILHSPH3M

```
PHASE      SORTRCN,*
INCLUDE    ILHSRCN
PHASE      SORTRSM,*
INCLUDE    ILHSRSM
INCLUDE    ILHSRSE
INCLUDE    ILHSRMC
PHASE      SORTRSN,*
INCLUDE    ILHSRSN
INCLUDE    ILHSRMC
PHASE      SORTROC,*
INCLUDE    ILHSROC      Merge Program
INCLUDE    ILHSRBG      Phase 3
INCLUDE    ILHSRPE
INCLUDE    ILHSACC
INCLUDE    ILHSABG
INCLUDE    ILHSASK
INCLUDE    ILHSASI
PHASE      SORTRGH,*
INCLUDE    ILHSRGH
INCLUDE    ILHSAGH
INCLUDE    ILHSAPH
END
```

CATALR ILHSPH3T

```
PHASE      SORTRSM,*
INCLUDE    ILHSRSM
INCLUDE    ILHSRSE
INCLUDE    ILHSRMC
PHASE      SORTRSN,*
INCLUDE    ILHSRSN
INCLUDE    ILHSRMC
PHASE      SORTROC,*
INCLUDE    ILHSROC      2400 Sort Program
INCLUDE    ILHSRBG      Phase 3
INCLUDE    ILHSRPE
```

```

INCLUDE ILHSAOC
INCLUDE ILHSABG
INCLUDE ILHSASK
INCLUDE ILHSASL
PHASE SORTRGF,*
INCLUDE ILHSRGF
INCLUDE ILHSAGF
INCLUDE ILHSAPF
END

```

CATALR ILHSPH31

```

PHASE SORTRSM,*
INCLUDE ILHSRSM
INCLUDE ILHSRSE
INCLUDE ILHSRMC
PHASE SORTRSN,*
INCLUDE ILHSRSN
INCLUDE ILHSRMC      2311 Sort Program
PHASE SORTROC,*      Phase 3
INCLUDE ILHSROC
INCLUDE ILHSRBG
INCLUDE ILHSRPE
INCLUDE ILHSAOC
INCLUDE ILHSABG
INCLUDE ILHSASK
INCLUDE ILHSASL
PHASE SORTRGF,*
INCLUDE ILHSRGF
INCLUDE ILHSAGF
INCLUDE ILHSAPF
PHASE SORTRGG,*
INCLUDE ILHSRGG
INCLUDE ILHSAGG
INCLUDE ILHSAPG
END

```

CATALR ILHSPH34

```

PHASE SORTRSM,*
INCLUDE ILHSRSM
INCLUDE ILHSRSE
INCLUDE ILHSRMC
PHASE SORTRSM,*
INCLUDE ILHSPSN
INCLUDE ILHSRMC
PHASE SORTROC,*
INCLUDE ILHSROC
INCLUDE ILHSRBG
INCLUDE ILHSRPE
INCLUDE ILHSAOC      2314 Sort Program
INCLUDE ILHSABG      Phase 3
INCLUDE ILHSASK
INCLUDE ILHSASL
PHASE SORTRGF,*
INCLUDE ILHSRGF
INCLUDE ILHSAGF
INCLUDE ILHSAPF
PHASE SORTRGG,*
INCLUDE ILHSRGG
INCLUDE ILHSAGG
INCLUDE ILHSAPG
END

```

Phase Names and Relocatable Module Names

<u>Phase Name</u>	<u>CSECT (Module Name)</u>	<u>Required</u>	<u>Program Phase</u>
SCRT	ILHSPP I	A	0-3
	I LHSRTMG	A	0
SORTRCA	ILHSRCL	A	0
	ILHSRCA	A	0
	I LHSRCM	A	0
SORTRCB	ILHSRCB	A	0
	I LHSRCI	A	0
	ILHSRCJ	A	0
SORTRCK	I LHSRCK	A	0
SORTRCC	ILHSRCC	A	0
SORTRCD	I LHSRCD	A	0
SORTRCE	ILHSRCE	T	0
SORTRCF	ILHSRCF	D	0
SORTRCH	I LHSRCH	M	0
SORTRCN	ILHSRCN	A	1,2,3
SORTRCD	I LHSRSD	S	1
SORTRSE	ILHSRSI	S	1
	I LHSRSE	S	1
	ILHSRMC	S	1
SORTASA	ILHSASA	S	1
SORTROA	ILHSROA	S	1
	ILHSAOA	S	1
SORTRDA	I LHSRDA	S	1
	ILHSADA	S	1
SORTRDB	I LHSRDB	S	1
	ILHSADB	S	1
SORTRDC	I LHSRDC	D	1
	ILHSADC	D	1
SORTRAA	ILHSRAA	T	1
	ILHSAAA	T	1
SORTRAB	ILHSRAB	D	1
	I LHSAAB	D	1
SORTRBA	ILHSRBA	S	1
	I LHSABA	S	1
SORTRBB	ILHSRBB	T	1
	I LHSABB	T	1
SORTRBC	ILHSRBC	D	1
	ILHSABC	D	1
SORTRBD	I LHSRBD	S	1
	ILHSABD	S	1
SORTRGA	ILHSRGA	S	1
	ILHSAGA	S	1
SORTRGB	I LHSRGB	S	1
	ILHSAGB	S	1
SORTRPA	I LHSRPA	T	1
	ILHSAPA	T	1
SORTRPB	ILHSRPB	D	1
	I LHSAPB	D	1
SORTRSG	ILHSRSG	S	2
SORTRSH	ILHSRSH	S	2
SORTRSJ	ILHSRSM	S	2
	I LHSRSJ	S	2
SORTRAC	ILHSRMC	S	2
	I LHSRAC	T	2
	ILHSRGD	T	2
	ILHSRPC	T	2
	I LHSAAC	T	2
	ILHSASG	S	2
	I LHSAPC	T	2

	ILHSAGD	T	2
SORTRAD	ILHSRAD	D	2
	ILHSRGE	D	2
	ILHSRPD	D	2
	ILHSAAD	D	2
	ILHSASG	S	2
	ILHSAPD	D	2
	ILHSAGE	D	2
SORTROB	ILHSROB	S	2
	ILHSRBF	S	2
	ILHSASF	S	2
	ILHSAOB	S	2
	ILHSABF	S	2
SORTRSM	ILHSRSM	M	3
SORTRSN	ILHSRSN	A	3
	ILHSRMC	A	3
SORTROC	ILHSROC	A	3
	ILHSRBG	A	3
	ILHSRPE	A	3
	ILHSAOC	A	3
	ILHSABG	A	3
	ILHSASK	A	3
	ILHSASL	A	3
SORTRGH	ILHSRGH	M	3
	ILHSAGH	M	3
	ILHSAPH	M	3
SORTRGF	ILHSRGF	S	3
	ILHSAGF	S	3
	ILHSAPF	S	3
SORTRGG	ILHSRGG	D	3
	ILHSAGG	D	3
	ILHSAPG	D	3

KEY

A - All programs
D - Direct access (2311,2314) Sort Programs
M - Merge Program
S - Entire Sort Program
T - 2400 Sort Program

Appendix F. BPS Device Type Specifications (DD)

The following device type codes can be entered in the Basic Programming Support ASSGN cards:

C1 1052 Printer-Keyboard
D1 2311 Disk Drive
D3 2314 Disk Drive
L1 1403 or 1404 Printer
L2 1443 or 1445 Printer
P1 2540 Card Read-Punch (punching only)
P2 1442 Card Read-Punch (punching only)
P3 2520 Card Read-Punch (punching only)
R0 2671 Paper Tape Reader
R1 2540 Card Read-Punch (reading only)
R2 2540 Using Punch-Read-Feed feature
R3 1442 Card Read-Punch (reading or reading and punching for combined files)
R4 2501 Card Reader
R5 2520 Card Read-Punch (reading or reading and punching for combined files)
RR 1285 Optical Reader
ST STR devices attached to 2701
T1 2400 7-track Tape
T2 2400 9-track Tape

Appendix G. Storage Requirements

Internal Storage Requirements

This section contains the data required for estimating three values:

1. The size of the supervisor required for a generated system,
2. The amount of main storage required at object-time for the supervisor and IOCS macro instructions, and
3. The internal storage requirements for relocatable subroutines required by COBOL, FORTRAN, Basic FORTRAN, and PL/I.

The supervisor size can be used to determine the size of the available problem-program area. Note that the background problem-program area must be at least 10,240 bytes when the Disk Operating System is used. However, if the COBOL compiler or the Assembler with both disk and tape work files is a part of the system, the minimum background area must be 14,336 bytes. If Assembler F is part of the system, the minimum background area must be 45,056 bytes. The supervisor varies in size from system to system according to the options chosen by the user and to the machine configuration.

The storage estimates shown in this publication are within 15% variance of actual requirements.

Supervisor

Figure 50 gives the main storage requirements for the base supervisors and the elements that can be included in a tailored supervisor. The base supervisor requirement for the batched job system is 5,902 bytes. Additional storage requirements must be added to the base requirement for each additional supervisor element desired that is not within the base requirement. For example, for OC=YES (FOPT) under batched job system, add 176 bytes to the base storage requirement (5,902 bytes). The base requirement for the MPS=YES supervisor is 6,870 bytes. For basic Telecommunication under MPS=YES, i.e. TP = BTAM, add 280 bytes to the base requirement for the MPS supervisor, thus an MPS supervisor that includes basic Telecommunication requires 7,150 bytes (see Figure 50). (Note that QTAM requires an MPS supervisor.) Thus, by the time the supervisor is tailored to the installation requirements, it usually is larger than the base requirements.

Note the relationship between the actual number of bytes in the 6K and 8K supervisors shipped by IBM and the number of bytes specified in the SEND macro for the respective supervisor.

<u>Size of Supervisor</u> <u>Shipped by IBM (in bytes)</u>	<u>Address Specified</u> <u>In SEND Macro (in bytes)</u>
6,144	6,144
6,592	8,192

The SEND macro specifies the beginning of the problem program area to facilitate system generation. Depending on the combination of supervisory functions chosen, a supervisor greater than 6,144 bytes may be generated.

Note: All supervisor generation options are described in the section Macro Instructions For Generating a Supervisor.

Supervisor Element	Generation Operand	MPS=		
		NO	YES	BJF
Required Routines (Basic Size)-SUPVR SVC Interruption Handling System Loader (FETCH and LOAD) I/O Units Control Tables (LUBS, PUBS, and JIBS) General Entry and Exit Routines Communication Region Transient Area End of Job Step Physical IOCS (including Selector Channel Support) Storage Protection (with MP)	SYSTEM=DISK	5902	6870	7166
Optional Routines				
Magnetic Character Options	MICR=1412 or 1419 (for 1259 see Note 1)	1440	1524	1524
	MICR=1419D	1284	1384	1384
Teleprocessing Options				
BTAM	TP=BTAM	376	280	280
QTAM	TP=QTAMn (Note 2)	--	872+[A]	872+[A]
Multitasking	AP=YES (Includes WAITM=YES)	--	2256	2256
1401/1440/1460 Emulator	EU=YES			
	IBM Model 2030	200	192	184
	IBM Model 2040	136	120	112

Figure 50. Supervisor Main Storage Requirements (Bytes) (Part 1 of 6)

Supervisor Element	Generation Operand	MPS=				
		NO	YES	BJF		
Configuration Options-CONFIG						
Model 30	MODEL=30	0	0	0		
Model 40	MODEL=40					
Model 50	MODEL=50			0		
Storage Protection	SP=YES	112	0	0		
Decimal Feature	DEC=YES	0	0	0		
Floating Point Feature	FP=YES	0	112	112		
Timer Feature	TIMER=YES	64	60	64		
	(with AP=YES, add 50 bytes)					
	TIMER=YES (with any MICR support)	160	156	156		
Functional Supervisor Options-FOPT						
User Option to Handle						
Operator						
Comm.	Prog Ck	Int Timer				
X			OC=YES	176	160	152
	X		PC=YES	128	200	200
		X	IT=BG, F1, F2	420	416	392
X		X	Note: If AP=YES when	424	408	408
	X	X	PC=YES, add 150	440	432	432
X	X		bytes.	264	264	264
X	X	X	If OC=YES when	464	472	472
			any MICR support is included, add 50 bytes.			
CE Serviceability Programs	CE=YES (Note 3)		864	864	850	
	CE=n (Note 9)		n+224	n+224	n+210	
Seek Separation	SKSEP=YES or n (Note 4)		288+4(n) + [a]+[b]	288+4(n) + [a]+[b]	288+4(n) + [a]+[b]	
Physical Transient Overlap	PTO=YES (Note 5)		--	416	424	
Console Buffering	CBF=n		554+106n	602+106n	602+106n	
	n may be 1 to 9 buffers					
	(If CHANQ is not elected--Note 6)		546+106n	602+106n	602+106n	

Figure 50. Supervisor Main Storage Requirements (Bytes) (Part 2 of 6)

Supervisor Element	Generation Operand	MPS=		
		NO	YES	BJF
Functional Supervisor Options - FOPT (continued)				
Multiple Wait	WAITM=YES (Note 7)	40	40	40
Abnormal Termination	AB=YES (without AP=YES)	472	456	456
	AB=YES (with AP=YES)	--	600	600
Track Hold	TRKHLD=n (without AP=YES) (Note 8)	--	660 +12n	660 +12n
	TRKHLD=n (with AP=YES) (Note 8)	--	750 +12n	750 +12n
Tape Error Statistics	TEB=n	42+8n	34+8n	34+8n
Command Chaining	CCHAIN=YES	24	24	24
Disk System Input and Output Files	SYSFIL=(2311 or 2314 [,n ₁ ,n ₂])	424	440	440
DASD File Protection (with 2321) (with Disk)	DASDFP=n ₁ , n ₂ , dev	528+24x (n ₂ -n ₁)	448+24x (n ₂ -n ₁)	440+24x (n ₂ -n ₁)
		456+24x (n ₂ -n ₁)	368+24x (n ₂ -n ₁)	384+24x (n ₂ -n ₁)
DASDFP (with 2321) <u>and</u> Disk SYSFIL		912+24x (n ₂ -n ₁)	846+24x (n ₂ -n ₁)	968+24x (n ₂ -n ₁)
DASDFP (with 2311) <u>and</u> Disk SYSFIL		848+24x (n ₂ -n ₁)	740+24x (n ₂ -n ₁)	908+24x (n ₂ -n ₁)

Figure 50. Supervisor Main Storage Requirements (Bytes) (Part 3 of 6)

Supervisor Element	Generation Operand	MPS		
		NO	YES	BJF
Job Control Options-STDJC (Job Control options affect only the contents of the communications region, not its size.)				
Physical IOCS Support-PIOCS				
Selector Channel Support	SELCH=YES	16	16	16
Burst Mode on Multiplexor Channel	BMPX=YES	48	48	48
Channel Switching Tape Control				
2404 or 2804	CHANSW=RWTAU	40	32	32
2816 only	CHANSW=TSWTCH	40	32	32
Tape Support				
7-track and 9-track, or 7-track only	TAPE=7	64	48	48
9-track only	TAPE=9	56	16	16
Allocate	ALLOC	0	0	0
Input/Output Tables-IOTAB				
Number of I/O devices on system	IODEV=n	8(n-10)	8(n-10)	8(n-10)
Number of programmer logical units	BGPGR=n F2PGR=n F1PGR=n	2(n-10)	2(n-10) 2(n-5) 2(n-5)	2(n-10)
Number of Channel Queue Entries	CHANQ=n (Note 6)	6(n-6)	6(n-6)	6(n-6)
Number of Job Information Blocks	JIB=n	4(n-5)	4(n-5)	4(n-5)

Figure 50. Supervisor Main Storage Requirements (Bytes) (Part 4 of 6)

Note 1. A 1259 is addressed as a 1419 single address adapter machine i.e., MICR=1419.

Note 2. MPS=YES or BJB is required for TP=QTAMn. TP=QTAMn includes BTAM supervisor support.

Telecommunications requires a minimum of two channels: one for the telecommunications; the other for the system resident device. An IBM 2701 Line Adapter Unit attached to an IBM System/360, Model 25, must be placed on the multiplexor channel.

If AP=YES when TP=QTAMn, then the quantity A must be added to the basic storage requirement for TP=QTAMn. $A=44+(n-2)12$, where n is the value elected for TP=QTAMn.

Note 3. If PTO=YES when CE=YES or CE=n, add 8 bytes to the CE storage requirement. The number of bytes indicated is the current storage requirement. In the future, these storage requirements may increase.

Note 4. When SKSEP=YES, n (in the formula) equals the number of DASD devices specified at system generation time. When SKSEP=n, n (in the formula) is the number of DASD devices supported as specified, but cannot be less than the number specified at system generation time. In either case, a (in the formula) is the 8 bytes required if DASDFP and/or SYSFIL options are selected, and b (in the formula) is the 8 bytes required if Teleprocessing (TP) option is selected.

Note 5. PTO=YES requires that MPS=YES or MPS=BJB for Physical Transient Overlap (PTO) support to be generated. For a description of Physical Transient Overlap (PTO), refer to IBM Systems/360 DOS Timing Estimates listed on the cover of this manual.

Note 6. The selection of the CBF option results in extra channel queue usage. Consider this when requesting the number of CHANQ entries. Thus, specification of the CBF option and election of the CHANQ default, which is 6 channel queue entries, results in the number of buffers specified being added to the CHANQ default. However, when both the CBF and CHANQ options are specified, the number of CHANQ entries desired should be increased by the number of buffers specified. Otherwise, the number of entries generated in the channel queue will be less than desired.

Figure 50. Supervisor Main Storage Requirements (Bytes) (Part 5 of 6)

Note 7. WAITM=YES is assumed when AP=YES.

Note 8. Where n equals the maximum number of tracks (1-255) to be held at any given time by the entire system. The default is 10 if n is an invalid parameter (non-numeric or outside the range, 1-255).

Note 9. If PTO=YES when CE=n, add 8 bytes to the CE storage requirement. In addition, if any of the following options are elected along with CE, subtract 8 bytes from the CE storage requirement under MPS=NO, or MPS=YES and subtract 24 bytes from the CE storage requirement under MPS=BJF.

- Multitasking (AP=YES)
- Track Hold (TRKHLD=n)
- Abnormal Termination (AB=YES)

The number of bytes indicated is the current storage requirement, where n is a minimum of 600 bytes. In the future, these storage requirements may increase.

Figure 50. Supervisor Main Storage Requirements (Bytes) (Part 6 of 6)

Supervisor size increases are not necessarily linear. For example, compare the size requirements of the separate entries OC=YES and PC=YES with the combined entry OC=YES,PC=YES. Combinations of elements may result in an actual supervisor size that is smaller than the calculated total derived for the same supervisor.

The I/O unit control tables in the IBM-supplied supervisor contain entries for up to 10 physical units and the first 10 programmer logical units. (See the IBM System/360 DOS System Control and System Service Programs publication listed on the front cover of this publication for a discussion of these tables.) The I/O table provides six channel queue positions and five job information blocks (JIB). As a minimum, 12 I/O devices and program check interrupts can be included within a 6,144 byte supervisor.

Because storage is protected in increments of 2K and other considerations, a DOS supervisor generated with any of the following options (with the exception of multitasking which forces the storage protection boundary to 10,240 bytes) requires a minimum of 8,192 bytes:

- Multiprogramming
- Telecommunications
- DASD File Protection
- Disk System Input/Output
- 1259/1412/1419 Magnetic Character Readers

If foreground areas are not used, the batch-job supervisor would probably be more useful because the multiprogramming supervisor requires additional space and time to perform its functions.

Computing the Size of a Supervisor

As an example, assume a supervisor is generated using the macros shown in Figure 51. The size of this supervisor is determined as illustrated.

GENERATION OPERAND		MAIN STORAGE REQUIREMENT (bytes)
SUPVR		
SYSTEM=DISK		6870
MPS=YES		
CONFG		
MODEL=40		0
SP=YES		0
DEC=YES		0
FP=YES		112
TIMER=YES		60
STDJC		0
FOPT		
IT=BG		472
PC=YES		
OC=YES		
CCHAIN=YES		24
DASDFP=(1, 2, 2321)	$[846 + 24(2-1)] =$	870
SYSFIL=2311		
TEB=4	$34 + 8(4) =$	66
PIOCS		
CHANSW=RWTAU		32
TAPE=7		48
BMPX=YES		48
IOTAB		
JIB=10	$4(n-5) =$	20
CHANQ=10	$6(n-6) =$	24
F1PGR=8	$2(n-5) =$	6
F2PGR=8	$2(n-5) =$	6
IODEV=10	$8(n-10) =$	0
BGPGR=10	$2(n-10) = 0$ (Note 1)	

Total Number of Bytes		8658

Note 1: If entry for BGPGR is below minimum requirement, n=10 is assumed. The following MNOTE is obtained for an entry of less than 10.

BGPGR SPECIFICATION BELOW MINIMUM - "10" ASSUMED

IBM		IBM System 360 Assembler Coding Form										PAGE OF											
PROGRAM		EXAMPLE ONE: TWO DISKS AND AT LEAST ONE TAPE										PAGE											
PROGRAMMER		DATE										PAGE ELECTRO NUMBER											
1	Name	8	10	Operand	14	16	20	Operand	26	30	32	36	40	44	48	52	Comments	60	64	68	72	76	80
//	EXEC	ASSEMBLY																					
		SUPVR SYSTEM=DISK,MP5=YES																					
		CONFIG MODEL=40,SP=YES,DEC=YES,FP=YES,TIMER=YES																					
		STDJC LISTX=YES,LINES=46																					
		FOPT IT=BG,PC=YES,OC=YES,CCHAIN=YES,DASDFP=(1,2,2321), X																					
		SYSFIL=(2311),TEB=4																					
		PIOCS CHANSW=RWTAU,TAPE=7,BMPX=YES																					
		ALLOC FI=6K,F2=6K																					
		IOTAB JIB=10,CHANQ=10,FI PGR=8,F2 PGR=8,IODEV=10,BGPGR=10																					
		DVCGEN CHUN=X'00C',DVCTYP=2540R																					
		DVCGEN CHUN=X'00D',DVCTYP=2540P																					
		DVCGEN CHUN=X'00E',DVCTYP=1403																					
		DVCGEN CHUN=X'01F',DVCTYP=1050A																					
		DVCGEN CHUN=X'190',DVCTYP=2311																					
		DVCGEN CHUN=X'191',DVCTYP=2311																					
		DVCGEN CHUN=X'192',DVCTYP=2321																					
		DVCGEN CHUN=X'180',DVCTYP=2400T7,CHANSW=YES																					
		DVCGEN CHUN=X'181',DVCTYP=2400T9,CHANSW=YES																					

IBM		IBM System 360 Assembler Coding Form										PAGE OF											
PROGRAM		EXAMPLE ONE: TWO DISKS AND AT LEAST ONE TAPE										PAGE											
PROGRAMMER		DATE										PAGE ELECTRO NUMBER											
1	Name	8	10	Operand	14	16	20	Operand	26	30	32	36	40	44	48	52	Comments	60	64	68	72	76	80
		ASSGN SYSRDR,X'00C'																					
		ASSGN SYSIPT,X'00C'																					
		ASSGN SYSPCH,X'00D'																					
		ASSGN SYSLST,X'00E'																					
		ASSGN SYSLOG,X'01F'																					
		ASSGN SYSLNK,X'191'																					
		ASSGN SYS001,X'191'																					
		ASSGN SYS002,X'191'																					
		ASSGN SYS003,X'191'																					
		ASSGN SYS004,X'191'																					
		ASSGN SYS007,X'192'																					
		SEND 10240																					
		END																					
		/*																					
		* CHECK ASSEMBLY LISTING FOR ERRORS. IF CORRECT																					
		* REMOVE ASSEMBLED SUPERVISOR FROM SYSPCH. INSERT IN READER																					
		* FOLLOWING THE INCLUDE CARD.																					
		// PAUSE TO CONTINUE PRESS EOB																					

Figure 51. Example of a Supervisor

Supervisor Macro Instructions

Figure 52 lists the main storage requirements for the expansion of the supervisor macro instructions. To determine the amount of main storage required for a given macro expansion, add both literal and variable requirements to the basic requirement.

Macro Instruction Name	NUMBER OF BYTES		
	Basic Storage Requirement	Additional Storage Required For Literals	Variable Requirements*
ATTACH	18 - 32	0 - 4	
CALL	2 - 16 *	0 - 4 *	+4 per operand
CANCEL**	4 - 6		
CHKPT	38 - 42 *		
COMRG	6		
DEQ	4 - 8	0 - 4	
DETACH	2 - 6	0 - 4	
DUMP	6	8	
ENQ	4 - 8	0 - 4	
EOJ	2		
EXIT	2		
FETCH	2 - 10 *	8 - 12 *	
GETIME	10 - 94 *	0 - 8 *	
LOAD	2 - 10 *	8 - 12 *	
MVCOM	12 - 16 *	0 - 4 *	
PDUMP	10 - 28	0 - 16 *	
POST	4 - 8	0 - 8	
RCB	8 - 10		
RETURN	2 - 6 *		
SAVE	4		
SETIME	6 - 14 *	0 - 8 *	
STXIT	2 - 14 *	4 - 12 *	
TECB	4		
WAIT (for TECB)	10 - 14 *	0 - 4 *	
WAITM	4 - 72		

* These values vary according to the selected options.

**Also; if user specifies CANCEL ALL, CANCEL increases two bytes.

Figure 52. Supervisor Macro Instructions Storage Requirements

Foreground Save Areas

A part of each foreground area is reserved for saving registers and for processing labels. The basic save-area size is 88 bytes. The following require additional space:

- +32 bytes for floating-point registers
- +84 bytes for nonsequential disk labels
- +80 bytes for standard tape labels.

MPS Utility Macro Instructions

Figure 53 gives the main storage requirements for the MPS utility macro instructions. These macros are designed so that a file-to-file utility program can fit in a 2K foreground program area (4K if the INTCR macro is used). To determine the size of the macro when expanded, add the variable requirements to, or subtract them from, the basic expansion requirement.

IOCS Declarative Macro Instructions

Figures 54-73 in this section give the main storage requirements for the IOCS declarative macro instructions. Where applicable, both the DTF table requirements and the logic module requirements are given. (See the Supervisor and I/O Macros publication listed on the front cover of this publication.)

The assembled tables and modules are included in the object program when it is linkage edited. The total storage requirement can be determined by adding the appropriate basic module requirement and the storage requirements for optional functions (for example, READ=BACK for magnetic tape files) to the table requirements for each file.

The core sizes in the tables may vary slightly according to the starting address of assembly; that is, boundary alignments may increase the core requirements for the various modules by 2-7 bytes.

	INTAPE	OUTAPE
Basic Macro Expansion	776	718
BUFSIZ= 80 n	+0 +2(n-80)	+0 +2(n-80)
RECSIZ= n name	226 260	
FILE= name (r)	-24 -12	140 120
LBL= name	324	+276
ERROR= SKIP IGNORE name	+8 0 +72	
CHKPT= NO name	-26 +28	
RETURN= NO YES		-6 +0
BLK= n name		+150 +182

	INDISK	OUTDISK
Basic Macro Expansion	816	1140
BUFSIZ= 80 n	+0 +2(n-80)	+0 +2(n-80)
FILE= name (r)	+24	+0 +12
LBL= name	+36	+36
RECSIZ= n name	260 268	
ERROR= SKIP IGNORE name	+24 +0 +100	0 148
RETURN= NO YES		0 +0
FORMAT= name FULL n		+68 +0 44
BLK= n name		150 182

Figure 53. MPS Utility Macro Storage Requirements (Part 1 of 3)

	INLOG	OUTLOG
Basic Macro Expansion	168	170
BUFFER= name (r)	+0 +4	+0 0
COUNT= n (r)	+ 0 -28	0 +4
RETURN= NO YES		-2 +0

	INCARD	OUTCARD
Basic Macro Expansion	418	444
STCTL= YES name		+60 +112
DEVICE= 2540 2520		+186 +48
RETURN= NO YES		+4 +0

	OUTPRT
Basic Macro Expansion	622
BUFSIZ= n	+2(n-144)
RETURN= NO YES	+10 +0
FORMS= A B C D	+28 +144 +114 +96

Figure 53. MPS Utility Macro Storage Requirements (Part 2 of 3)

INTCR				
	INPUT= MTST, STDUC or MST, STDLC	INPUT= MTST, name1	INPUT= MTST, NOTRAN or MTDI, NOEDIT	INPUT= MTDI, EDIT or MTDI, EDITR
Basic Macro Expansion	1158	1023	570	1720
BUFSIZ= (n) (n, m1)	+3n +2n+m1	+3n +2n+m1	+3n +2n+m1	+3n +2n+m1
RECFORM= VAR UNDEF	+0 -16	+0 -16	+0 -16	+0 -16
ERROPT= IGNORE name2	+0 +106	+0 +106	+0 +106	+0 +134

Figure 53. MPS Utility Macro Storage Requirements (Part 3 of 3)

DTFCD (DEFINE THE FILE: CARD)

Table Requirements

TYPEFLE=INPUT requires 50 bytes.

TYPEFLE=CMBND requires 84 bytes.

TYPEFLE=OUTPUT requires 48 bytes.

CRDERR=RETRY (2540 only) requires an additional 88 bytes.

DEVICE=2520 requires 8 additional bytes.

CDMOD (CARD MODULE)

RECFORM=	IOAREA2=	WORKA=	TYPEFLE					
			INPUT	OUTPUT			CMBND	
			1442 2520 2540 2501	1442	2520	2540	1442	2520 2540
FIXUNB	-	-	90	74	80	40	126	198
FIXUNB	-	YES	106	116	122	84	154	226
FIXUNB	YES	-	122	118	124	82	126	198
FIXUNB	YES	YES	138	132	138	96	154	226
UNDEF	-	-	-	112	110	70	-	-
UNDEF	-	YES	-	124	132	92	-	-
UNDEF	YES	-	-	128	130	90	-	-
UNDEF	YES	YES	-	140	146	104	-	-
VARUNB	-	-	-	126	132	94	-	-
VARUNB	-	YES	-	140	146	108	-	-
VARUNB	YES	-	-	154	160	118	-	-
VARUNB	YES	YES	-	156	162	120	-	-

Figure 54. CDMOD Main Storage Requirements (Part 1 of 2)

Notes:

1. CTLCHR=YES or ASA; depending upon record format, number of I/O areas, and/or work area specifications:

for YES, a minimum of 8 to a maximum of 36 additional bytes are required.

for ASA, a minimum of 28 to a maximum of 65 additional bytes are required.

2. RDNLY=YES changes the size of the modules -50 to +50 bytes. In addition, the user's program must provide a 72-byte save area each time the module is reentered.
3. Part 2 of Figure 54 shows the requirements for the other CDMOD options. The values selected must be added to the TYPEFLE value to determine the amount of storage needed.

CRDERR=RETRY	2520	2540
without IOAREA2 or WORKA	+73	+123
with either or both	+69	+119

CONTROL=YES	1442	2540	2520
INPUT	+24	+30	+30
OUTPUT without WORKA	+24	+20	+12
OUTPUT with WORKA	+24	+32	+12
CMBND without WORKA	+24	+20	+12
CMBND with WORKA	+32	+32	+12

Figure 54. CDMOD Main Storage Requirements (Part 2 of 2)

DTFCN (DEFINE THE FILE: CONSOLE)

		TYPEFLE=	
RECFORM=	WORKA=	INPUT/OUTPUT	OUTPUT only
FIXUNB	-	94	60
FIXUNB	YES	150	90
UNDEF	-	156	114
UNDEF	YES	262	168

Note: No module is required for this macro instruction.

Figure 55. DTFCN Main Storage Requirements

DTFDA (DEFINE THE FILE: DIRECT ACCESS DEVICE)

Table Requirements

RECFORM=FIXUNB requires 205-225 bytes, depending upon imperative macros used in the DTF.

VERIFY=YES requires 40-80 bytes, depending upon imperative macros used in the DTF.

AFTER=YES requires 80 additional bytes.

RECFORM=UNDEF requires 265-285 bytes, depending upon imperative macros used in the DTF.

VERIFY=YES requires 40-80 additional bytes, depending upon imperative macros used in the DTF.

AFTER=YES requires 16 additional bytes.

Relative addressing increases the size of the DTF 60-80 bytes plus 8 bytes per extent. (See IBM System/360 Disk Operating System, Supervisor and Input/Output Macros listed on the front cover of this manual.)

DAMOD (DIRECT ACCESS DEVICE MODULE)

			Formatting Module				
RECFORM=	Basic Module	IDLOC	AFTER	AFTER and IDLOC	RELTRK	HOLD	ERREXT
FIXUNB	392	+216	+304	+520	+208	+68	+28
UNDEF	556	+228	+208	+436	+212	+72	+28

Notes:

1. Basic Module includes coding to handle either FIXUNB or UNDEF records and the WRITEKY, READKEY, READID, WRITEID, SRCHM, VERIFY, and CONTROL functions.
2. AFTER includes coding to create the file and to handle the RZERO option.
3. IDLOC includes coding to return the record identifier to the user in a location he specifies.
4. Specification of trailer label processing in the DTF increases the size of each module by 50 ± 20 bytes.
5. RDNLY=YES changes the size of the module -50 to +50 bytes. In addition, the user's program must provide a 72-byte save area each time the module is reentered.

Figure 56. DAMOD Main Storage Requirements

DTFIS (DEFINE THE FILE: INDEXED SEQUENTIAL)

Table Requirements

1. IOROUT=LOAD requires 248 bytes plus 4 bytes per disk extent specified, plus 8 bytes for IOAREA2.
2. IOPOUT=ADD requires 530 bytes plus 4 bytes per disk extent specified plus KL (the length of the key).

3. IOROUT=RETRVE requires 276 bytes plus 4 bytes per disk extent specified, when TYPEFLE=SEQNTL.
4. IOROUT=RETRVE requires 292 bytes plus 4 bytes per disk extent specified when TYPEFLE=RANDOM or RANSEQ.
5. IOROUT=ADDRTR requires 548 bytes plus 4 bytes per disk extent specified plus KL (the length of the key).
6. IOROUT=ADDRTR, TYPEFLE=RANDOM, INDAREA=name, and INDSIZE=n require 300 bytes plus 4 bytes per disk extent.

ISMOD (INDEXED SEQUENTIAL MODULE)

		IOROUT =							
		LOAD				ADD			
		ERREXT	IOAREA2	ERREXT		CORDATA	ERREXT	CORDATA	
				IOAREA2				ERREXT	
RECFORM=									
FIXUNB						2572	+184	+476	+660
FIXBLK						2786	+272	+498	+770
BOTH	811	+224	+212	+436		3032	+246	+428	+674

● Figure 57. ISMOD Main Storage Requirements (Part 1 of 5)

		IOROUT=RETRVE							
		TYPEFLE=							
		RANDOM		SEQNTL			RANSEQ		
		ERREXT		ERREXT	IOAREA2	ERREXT		ERREXT	
					IOAREA2				
RECFORM=									
FIXUNB									
FIXBLK									
BOTH	1276	+302	1260	+246	+386	+632	2116	+332	

● Figure 57. ISMOD Main Storage Requirements (Part 2 of 5)

		IOROUT=ADDRTR							
		TYPEFLE=							
		RANDOM				SEQNTL			
		CORDATA	ERREXT	CORDATA	ERREXT	CORDATA	IOAREA2	CORDATA	ERREXT
RECFORM=								IOAREA2	
FIXUNB	3216	+184	+534	+718	3420	+94	+386	+480	+510
FIXBLK	3432	+272	+554	+826	3634	+272	+386	+658	+528
BOTH	3676	+246	+588	+834	3880	+274	+386	+660	+558

Figure 57. ISMOD Main Storage Requirements (Part 3 of 5)

		IOROUT=ADDRTR			
		TYPEFLE=РАНSEQ			
		CORDATA	ERREXT	CORDATA	ERREXT
RECFORM=					
FIXUNB	4056	+194	+556	+750	
FIXBLK	4272	+272	+584	+856	
BOTH	4516	+248	+616	+864	

Figure 57. ISMOD Main Storage Requirements (Part 4 of 5)

- Note 1: When RECFORM=BOTH is specified, the module processes FIXUNB and FIXBLK records.
- Note 2: For CORINDX = YES, add 212 bytes.
- Note 3: RDCONLY=YES changes the module size by ±50 bytes with the following exceptions. When IOROUT=ADD or IOROUT=ADDRTR, the module changes in size +60 to +100 bytes. In addition, the user's program must provide a 72-byte save area each time the module is reentered, regardless of function.

Figure 57. ISMOD Main Storage Requirements (Part 5 of 5)

DTFMR (DEFINE THE FILE: MAGNETIC CHARACTER READER)

Table Requirements

If ADDRESS=DUAL is specified, the table requires 264 bytes.

If ADDRESS=DUAL is not specified, the table requires 250 bytes.

MRMOD (MAGNETIC CHARACTER READER MODULE)

If ADDRESS=DUAL is specified, the module requires 1,050 bytes.

If ADDRESS=DUAL is not specified, the module requires 946 bytes.

DTFDI (DEFINE THE FILE: DEVICE INDEPENDENT SYSTEM UNITS)

Table Requirements

240 bytes

DIMOD (DEVICE INDEPENDENT SYSTEM UNITS MODULES)

TYPEFLE=	Basic Module	IOAREA2=YES
INPUT	308	+60
OUTPUT	643	+80

Note: RDONLY=YES changes the size of the module -50 to +50 bytes. In addition, the user's program must provide a 72-byte save area each time the module is reentered.

Figure 58. DIMOD Main Storage Requirements

DTFMT (DEFINE THE FILE: MAGNETIC TAPE)

Table Requirements

TYPEFLE=WORK requires 48 bytes per work file.

The table requirements for INPUT and OUTPUT files are:

TYPEFLE=	RECFORM =	Basic Size Without STDLABELS	ERROPT, ERREXT (Without STDLABELS)	Basic Size With STDLABELS	ERROPT, ERREXT (With STDLABELS)
INPUT	FIXUNB OR FIXBLK	96	*	112	*
	VARUNB OR VARBLK	109	*	128	*
	UNDEF	92	*	108	*
OUTPUT	FIXUNB OR FIXBLK	86	+10	104	+4
	VARUNB OR VARBLK	98	+10	116	+4
	UNDEF	84	+4	100	+4

* Included in basic Size of Module.

MTMOD (MAGNETIC TAPE MODULE)

MAGNETIC TAPE MODULE					
RECFORM=	BASIC MODULE	INDEPENDENT OPTIONS			
		WORKA= YES	CKPTREC= YES	READ= BACK	ERREXT
FIXUNB/FIXBLK	846	+80	+136	+48	+64
VARUNB/VARBLK	890	+120	+144	+80	48
UNDEF	672	+80	+144	+16	+64

Notes :

1. Only one module is required for processing all files having a common RECFORM. This module can be generated with the options charted above. To determine the size of the module with the options, the number of option bytes specified in the chart must be added to the basic module.
2. RDONLY=YES, changes the size of the module -50 to +50 bytes. In addition, the user's program must provide a 72-byte save area each time the module is reentered.

WORKFILE MODULE			
TYPEFILE=WORK	without NOPEPNT	NOPEPNT=	
		YES	POINTS
without ERROPT	232	450	286
with ERROPT	322	540	380
with ERROPT & ERREXT	436	654	494

Figure 59. MTTMOD Main Storage Requirements

DTFOR (DEFINE THE FILE: OPTICAL READER)

Table Requirements

1. RECFORM=FIXUNB requires 136 bytes.
2. RECFORM=FIXBLK varies as a function of blocking.
Size = 136 + (16 x blocking factor x number of I/O areas)
3. RECFORM=UNDEF requires 136 bytes.

ORMOD (OPTICAL READER MODULE)

DEVICE=	RECFORM=	Basic Module	INDEPENDENT OPTIONS			
			CONTROL= YES	IOAREA2= YES	WORKA= YES	IOAREA2= YES and WORKA= YES
1285 or 1287T	FIXUNB	892	+220	+76	+60	+96
	FIXBLK	1256	+264	+56	+28	+84
	UNDEF	848	+224	+56	+64	+88
	UNDEF BLKFAC=YES	1180	+268	+56	+24	+80
1287D	FIXUNB	1360	+184	---	---	---
	UNDEF	1256	+188	---	---	---

Figure 60. ORMOD Main Storage Requirements

DTFPH (DEFINE THE FILE: PHYSICAL IOCS)

Device	Size
Tape	104
DASD MOUNTED=ALL	40
DASD MOUNTED=SINGLE	84

Note: No module is required for this macro instruction.

Figure 61. DTFPH Main Storage Requirements

DTFPR (DEFINE THE FILE: PRINTER)

Table Requirements

Size = 48 bytes

PRMOD (PRINTER MODULE)

RECFORM=	BASIC MODULE	WORKA=YES	IOAREA2=YES	PRINTOV	CTLCHR=		
					ASA	YES	CONTROL=YES
FIXUNB	40	+44	+42	+78	+188	+34	+40
UNDEF	70	+22	+20	+76	+170	+16	+40
VARUNB	94	+14	+24	+76	+162	+8	+40

Note: RDNLY=YES changes the size of the module -50 to +50 bytes. In addition, the user's program must provide a 72-byte save area each time the module is reentered.

Figure 62. PRMOD Main Storage Requirements

DTFPT (DEFINE THE FILE: PAPER TAPE READER)

Table Requirements

The possible table specifications and sizes are:

1. No translations, no shifts, and no deletes require 72 bytes.
2. TRANS=name with no shifts and no deletes requires 76 bytes.
3. TRANS=name, SCAN=name, RECFORM=FIXUNB require 110 bytes.
4. TRANS=name, SCAN=name, RECFORM=UNDEF require 94 bytes.

PTMOD (PAPER TAPE READER MODULE)

The module specifications and sizes are:

1. No parameters specified (no translations, no shifts, and no deletes) requires 252 bytes.
2. TRANS=YES with no shifts and no deletes requires 310 bytes.
3. TRANS=YES, SCAN=YES, RECFORM=FIXUNB require 536 bytes.
4. TRANS=YES, SCAN=YES, RECFORM=UNDEF require 436 bytes.

Note: If module 2 is used, all records require translation.

DTFSD (DEFINE THE FILE: SEQUENTIAL DASD)

RECFORM=	TYPEFLE					CONTROL = YES
	INPUT		OUTPUT	WORK		
	with UPDATE	without UPDATE		with UPDATE	without UPDATE	
FIXBLK or FIXUNB	176	152	160	152	152	+24
VARBLK or VARUNB	192	152	170	---	---	+24
UNDEF	192	152	162	152	152	+24

Figure 63. DTFSD Main Storage Requirements

SDMOD (SEQUENTIAL DASD MODULE)

Module Name	Basic Module	TRUNCS	CONTROL	ERROPT	HOLD	ERROPT ERREXT
SDMODFI	462	+80	+28	+144	*	+228
SDMODFO	546	+136	+28	+64	*	+200
SDMODFU	798	+88	+28	+164	+96	+252
SDMODVI	729		+28	+104	*	+188
SDMODVO	1045		+28	+68	*	+120
SDMODVU	1086		+28	+176	+76	+296
SDMODUI	533		+28	+100	*	+171
SDMODUO	653		+28	+68	*	+116
SDMODUU	941		+28	+148	+40	+248
SDMODW	572		+22	+148	+10	+246

*The HOLD function does not apply to these modules.

Notes:

1. For SDMODW, NOTEPNT=YES requires 206 additional bytes; NOTEPNT=POINTRW requires 144 additional bytes, UPDATE=YES requires 40 additional bytes.
2. RDONLY=YES changes the size of the module -50 to +50 bytes. In addition, the user's program must provide a 72-byte save area each time the module is reentered.

Figure 64. SDMOD Main Storage Requirements

DTFSR (DEFINE THE FILE: SERIAL DEVICE)

When a DTFSR is assembled, it generates both a table and a module. For example, if DTFSR is used for a printer, a table and a module are generated just as though DTFPR and PRMOD were used. To determine the main storage requirements for DTFSR, add the table and the module requirements for the appropriate device type--such as 48 bytes (DTFPR) and n bytes (PRMOD) for a printer.

DTFET (DEFINE THE FILE: BTAM)

Table Requirements

$$\text{Size} = 64 + N (40 + 8x) + \text{BUFNO} (\text{BUFL} + f) + y + z \\ (+ 32N \text{ for BSC only})$$

where: N = number of lines in the line group
x = number of CCWs in the largest channel program available for the device, given in Figure 65
*BUFCB = 8 if a buffer pool is used
= 0 if not
*BUFNO = number of buffers in the pool
*BUFL = length of each buffer
f = number of bytes required to extend each buffer to a multiple of 8
y = size of the model channel program table for the line group, given in Figure 65. If two or more DTFBTs use the same model channel program and are linkage edited together, include the value only once.
z = size of the table of special characters, given in Figure 60. For BSC only, if two or more DTFBTs use the same transmission code, include the value only once.

*If the buffer pool is shared by 2 or more DTFBTs, include the value only once.

Device	x		y	z
	without	with		
	start/stop	Auto Poll		
1030	7	9	84	23
1050NS	7	9	68	16
1050S	11		136	34
1060	6	9	80	15
2260L	1		Not applicable	Not applicable
2260R	7		136	20
2740	4		24	21
2740C	4		68	33
2740D	6		52	18
2740DC	7		100	32
2740DT	8		68	22
2740DTC	8		116	36
2740S	6	9	48	12
2740SC	7	9	84	24
7770/72	4		52	0
115A	4		36	4
83E3	5		40	6
TWX 33/35	7		56	18
WTTA	5		52	36
1130 (leased)	8		148	53
1130 (dial)	8		196	53
1130 (multipoint)	8		164	53
S360 (leased)	8		240	53
S360 (dial) size depends on codes in the FEATURE operand:				
No ID Verif.	8		296	53
RIW	8		300	53
SIW,RXW	8		324	53
SXW,RXW	8		300	53
SIX,RXW	8		324	53
RXW	8		300	53
SIW,RIX	8		320	53
SXW,RIX	8		296	53
SIX,RIX	8		320	53
RIX	8		296	53
SIW	8		320	53
SXW	8		296	53
SIX	8		320	53
SIW,RIW	8		324	53
SXW,RIW	8		300	53
SIX,RIW	8		324	53
2780				
Pt to Pt Switched				
EBCDIC	8		140	53
USASCII	8		140	53
TRANSCODE	8		140	53
Pt to Pt Non Switched				
EBCDIC	8		96	53
USASCII	8		96	53
TRANSCODE	8		96	53
Multipoint				
EBCDIC	8		132	53
USASCII	8		84	53
TRANSCODE	8		84	53

Figure 65. Parameters for DTFBT Table Requirements Formula

DTFBTND (DEFINE THE FILE END: BTAM)

This macro instruction does not require main storage at execution time.

DFTRMLST (DEFINE THE TERMINAL LIST: BTAM)

Table Requirements for OPENLST and WRAPLST

$$\text{Size} = n(m + 1) + 2$$

where: n = number of list entries
m = number of polling/addressing characters--a function of the device, as shown in Figure 66

Device	m
1030	1
1050NS	2
1050S	2
1060	2
2260L	Not applicable
2260R	2
2740	Not applicable
2740C	Not applicable
2740D	Not applicable
2740DC	Not applicable
2740DT	Not applicable
2740DTC	Not applicable
2740S	1
2740SC	1
7770/72	Not applicable
115A	2
83B3	2
1130	2
2780	3
WTTA	Not applicable

Figure 66. Number of Polling/Addressing Characters

Table Requirements for DIALST

$$\text{Size} = n(m + 1) + 1 + q + p + i$$

where: n = number of list entries
m = values specified in Figure 66
q = 2 if the list includes entries for polling or addressing
= 0 otherwise
p = number of dial digits
i = 3 if the inlist operand is coded (BSC only)
= 0 otherwise

Table Requirements for IDLST

Size of TWX calling list = $d + 5 + 2b$
Size of TWX answering list = $5 + b$
Size of BSC IDLST only = $3 + d + 2r + s + i$

where: d = number of dial digits
 b = number of TWX ID characters
 r = number of ID characters expected to be received (BSC)
 s = number of ID characters to be sent (BSC)
 i = 3 if the inlist operand is coded (BSC)
= 0 otherwise

Table Requirements for SSLAST/SSAWLST

Size = $n(m + 1) + 6$

where: n = number of list entries
 m = values specified in Figure 66

Table Requirements for AUTOLST/AUTOWLST

Size = $n(m + 2) + 8$

where: n = number of list entries
 m = values specified in Figure 66

Table Requirements for WTTALST

1. When the WRU feature is present in DTFBT:

Size = $3 + 2r + s$

2. When the IAM feature is present, and WRU is not present in DTFBT:

Size = $2 + s$

where: r = number of ID characters expected to be received
 s = number of ID characters to be sent

BTMOD (BTAM LOGIC MODULE)

The size of the BTAM module varies with the options selected, as shown in Figure 67. When all operands are omitted or the standard (default) options are coded, the resulting basic module requires 4770 bytes of main storage.

Operand	Option	Number of bytes added to basic module
ERLOGIC=	N	-2090
	C	+ 320
	NC	-1830
SWITCH=	YES	+ 290
AUDIO=	YES	+ 410 (SWITCH must equal YES)
BUFFER=	YES	+1740
	REQREL	+ 640
TERMST=	YES	+ 750
L2260=	YES	-1280 (If ERLOGIC=N)
		+1050 (If ERLOGIC=E)
		+1360 (If ERLOGIC=C)
		-1020 (If ERLOGIC=NC)
TRANSL=	YES	+ 140
BSCS=	YES	+9380 (If SWITCH=YES and BUFFER=YES)
		+6640 (If SWITCH=YES and BUFFER=NO)
		+5290 (If SWITCH=NO and BUFFER=NO)
		+8020 (If SWITCH=NO and BUFFER=YES)
SSAPL=	YES	- 970 (If ERLOGIC=N)
		+1560 (If ERLOGIC=E)
		- 700 (If ERLOGIC=NC)
		+1880 (If ERLOGIC=C)
BSCMPT=	YES	+ 880 (BSCS must equal YES)
WTTA	YES	+ 320
BSCTEST	YES	+1690
DECBEXT	YES	- 50 (BSCS must equal YES)

Figure 67. BTAM Main Storage Requirements

BTAM DATA EVENT CONTROL BLOCK

Table Requirements

Size = 40 bytes

When the MF operand of a READ or WRITE macro is coded MF=L, or when the MF operand is omitted, a Data Event Control Block (DECB) is reserved. One DECB should be reserved per line.

QTAM STORAGE REQUIREMENTS

The main storage requirements for QTAM depend to a great extent on the configuration of the user's Teleprocessing installation and the nature of his applications. Storage requirements increase proportionately as the number of communication lines, terminals, and QTAM-provided processing functions increase. These requirements can be estimated from formulas and tables presented in this section.

BASIC QTAM LOGIC MODULES

Figure 68 lists the basic QTAM logic modules and corresponding storage requirements.

Module	Module Name	Storage Requirements (in bytes)
Implementation module	IJLQIP	3749
LPS Control Module	IJLQLP	1010
Line Appendage for PCI and Program Check module (Note 4)	IJLQLA	728
Line Appendage and ERP Module (Note 4)	IJLQEP	4160
Audio Line Appendage module (Note 1)	IJLQAA	2376
Disk Appendage module (Note 4)	IJLQDA	1365
Audio Disk Appendage module (Note 2)	IJLQAD	1604
Physical I/O module (Note 4)	IJLQRW	1521
Terminal Test Recognition module (Note 4)	IJLQTT	1386
Checkpoint module (Note 3)	IJLQCK	1148
Message Writer Initiator module	IJLQMW	1255
IBM 2260 Local Appendage module (Note 5)	IJLQLO	1604
WTTA Appendage Module (Note 6)	IJLQTA	1370

Note 1: Required if the QTAM Audio Support is selected.

Note 2: Required if the IBM 7772 Vocabulary file is used.

Note 3: Required if the Checkpoint/Restart facility is selected in the DTFQT.

Note 4: Not required when the system contains only audio devices.

Note 5: Required if the IBM 2260 Local device is used.

Note 6: Required if World Trade Telegraph support is selected.

Figure 68. Basic QTAM Logic Modules

DTFQT (DEFINE THE FILE: QTAM)

There are seven types of DTF tables which may be generated by a DTFQT macro instruction. The storage estimates for each follow.

Table Requirements for DASD Message Queues File

Size = 315 bytes

Table Requirements for Communication Line Group File

For Nonaudio Line Group

$$\text{Size} = 48 + (128 + 8x)N$$

For Audio Line Group

$$\text{Size} = 64 + P + (161 + L_1 + L_2 + G + x-z)N$$

where: N = number of lines in the line group
 x = a function of the device, given in Figure 69
 P = 22 for IBM 7772 only
 L₁ = length of input buffers
 L₂ = length of address chain buffers
 G = 9 when using time stamping option, otherwise = 0
 z = 17 when information mode is used

Device	x	Device	x
1030	8	274E	7
1050NS	8	274F	4
1050S	10	274G	6
1060	7	274H	7
2260 Remote	8	115A	8
2260 Local	5	83B3	7
274A	4	TWX33/35	6
274B	6	7770	0
274C	6	7772	60
274D	7	WTTA	7

Figure 69. Values for Communication Line Group Table

Table Requirements for Main Storage Process Queue

$$\text{Size} = 84 + 12x$$

where: x = 0 for nonmixed application, and
 1 for mixed application

Table Requirements for Main Storage Destination Queue

$$\text{Size} = 80 \text{ bytes}$$

Table Requirements for Checkpoint Records File

$$\text{Size} = 220+L$$

where: L = length of the Checkpoint record specified by the SOWA keyword operand.

Table Requirements for IBM 7772 Vocabulary File

$$\text{Size} = 40+4p$$

where: p = number of BUFARU macro instructions

Table Requirement for Audio Output Queue

Size = 76 bytes

QTAM STORAGE REQUIREMENTS FOR CONTROL INFORMATION

The storage estimates for required control information are shown in Figure 70.

Control Blocks and Information	Storage Requirements (in bytes)
Terminal table TERMTBL macro instruction ¹	12
OPTION macro instruction	No storage is reserved for this macro; it defines user areas that are included in the expansion of the TERM macro instruction (U parameter)
TERM macro instruction ¹	$9 + I + U + D + 44F$ where: $(I + U + D) \leq 243$
LLST macro instruction ¹	$12 + L + 2N + 140^2$ where: $(3 + L + 2N) \leq 243$
PROCESS macro instruction ¹	13 + A for audio process program entry 9 + Y for nonaudio process program entry
Pcilling list POLL macro instruction ³	4 + 3N for autopollled terminals except IBM 1030 4 + 2N for nonswitched terminals or autopollled IBM 1030 5 for switched IBM terminals 3 + I for TWX 4 + T for WTTA terminals
Queue Control Block for Process Queues and Destination Queues	32X
Audio Line Table LINETBL macro instruction ¹	4
LINE macro instruction ¹	5 + Z
Audio Word Table WORDTBL macro instruction ¹	4
WORD macro instruction ¹	8 + W

Figure 70. Storage Requirements for QTAM Control Information (Part 1 of 2)

where: N = number of terminals
I = number of bytes in terminal ID
U = number of bytes in optional area
D = number of bytes in device address area; size depends on contents:

For nonswitched terminal--addressing and polling characters (1 byte/character)

For IBM switched terminal--field telling the number of dial digits (1 byte) + dial digits (1 byte/digit) + addressing characters (1 byte/character)

For TWX--field telling the number of dial characters (1 byte) + dial digits (1 byte/digit) + field telling the number of ID characters (1 byte) + ID characters (2 bytes/character)

For WTTA terminals--1 byte + field telling the number of ID characters (1 byte) + ID characters (2 bytes/character)

For IBM 2260 Local--a field of 6 full words consisting of a CCB and other control information

L = number of bytes in name of the distribution list entry in terminal table (1-8)

A = number of bytes in name of the audio process entry in the terminal table. Because the following field in the entry must be aligned to a fullword boundary, this field must be either three, seven or eleven bytes long.

X = number of lines or terminals (depending on queuing techniques) and the number of process queues

Y = number of bytes in name of the process entry in terminal table (1-8)

Z = number of bytes in name of the line entry in line table (1-8)

W = number of bytes of the selected word

F = 1 for IBM 2740 Model 2 terminals with the Buffer Receiver Option; 0 for other terminals

T = number of bytes in the CPU identification (WTTA terminals)

Notes:

1. Add the number of bytes necessary for fullword boundary.
2. This number (140) is the number of bytes in the Distribution List module (IJLQDL). This number is included in the storage requirements only once if the LIST macro is used more than once.
3. Add the number of bytes necessary for halfword boundary.

Figure 70. Storage Requirements for QTAM Control Information
(Part 2 of 2)

QTAM REQUIREMENT FOR BUFFERS

For Nonaudio Applications:

$$\text{Buffer Pool Size} = 8 + (X + 16)N + 24M$$

For Audio Applications with IBM 7772:

$$\text{Audio Buffer Pool Size} = 24 + (X + 88)N$$

where: N = number of buffers specified
 X = size of each buffer
 M = number of CCWS QTAM generates for data insertion by the PAUSE macro

QTAM STORAGE REQUIREMENTS FOR DEVICE I/O MODULES

Figure 71 gives the storage requirements for the QTAM device I/O modules. The storage for a particular device I/O module need be included only once and only if the terminal type is present in the system.

Terminal Device Type	Module Name	Storage Requirements (in bytes)
IBM 1030 Data Collection System	IJLQM0	194
IBM 1060 Data Communications System	IJLQM1	168
IBM 2260-2848 Display Complex	IJLQM2	206
AT&T 83B3 Selective Calling Stations	IJLQM3	102
Western Union Plan 115A Outstations	IJLQM4	90
IBM 1050 Data Communications System on a switched network	IJLQM5	207
IBM 1050 Data Communications System	IJLQM6	194
AT&T Model 33/35 TWX Stations	IJLQM8	113
IBM 2260-2848 Display Complex Local	IJLQM9	75
IBM 2740 Communications Terminal:		
Type 274A	IJLQN0	90
Type 275B	IJLQN1	157
Type 274C	IJLQN2	162
Type 274D	IJLQN3	221
Type 274E	IJLQN4	198
Type 274F	IJLQN5	119
Type 284G	IJLQN6	183
Type 275H	IJLQN7	156
World Trade Telegraph Terminals	IJLQN8	300

Figure 71. Storage Requirements for QTAM Device I/O Modules

REQUIREMENTS FOR OTHER QTAM MACRO INSTRUCTIONS

Figure 72 gives the storage requirements for all other QTAM macro instructions.

Much QTAM logic consists of modules introduced by the use of certain QTAM macro instructions in the user's program. These macro instructions expand into in-line coding that establishes the linkage to, and parameters for, the QTAM modules. Often a module so introduced into the system will itself introduce another module, a process termed a second level routine.

Column two of Figure 72 shows the extent of the coding produced by the expansion of the macro instruction in column one. If the coding links to a QTAM module, the module is presented in column three; if that module links to other modules, they are presented in column four.

Storage requirements for a sharable module, or for a second level routine that is linked to more than once in the same partition, are included only once. For example, the macro instructions DIRECT, EOA, and ROUTE all link to the same module, LJLQLK. If two or more of these macro instructions are used in the same message control program, the module is included only once. Similarly, if the same macro instruction is used more than once in the same program, storage is required for only the additional linkage since the module is included just once.

Macro Instruction	In-line linkage or code Note 5	Sharable modules		Second level routine	
		Size	Name	Size	Name
ARUMGTYP	16				
BREAKOFF	8	164	IJLQBO		
CANCELM	8	112	IJLQCM		
CHECKARU	70+ message text				
CHNGP	42	146	IJLQCP	78	IJLQFL
CHNGT	26	250	IJLQCT		
CKREQ	10	100	IJLQCR		
CLOSEMC	6	514	IJLQQT	512	IJLQCL
COPYC	24	414	IJLQDC		
COPYP	34	104	IJLQDP	78	IJLQFL
COPYQ	34	98	IJLQDQ		
COPYT	30	120	IJLQDE		
COUNTER	12				
DAT ESTMP	8	70	IJLQDT	70	IJLQEX
DIRECT	12	104	IJLQLK		
ENDRCV	10		Note 1		
ENDRCV (WTTA)	16	132	IJLQEB		
ENDREADY	80		Note 1		
ENDSEND	10		Note 1		
EOA	28	100	IJLQEA	104 76 48 60 104 Note 2	IJLQSH IJLQSK IJLQRG IJLQMT IJLQLK
EOB	6	132	IJLQEB		Note 1
EOBLC	6	380	IJLQEC		Note 1

Figure 72. Storage Requirements for Other QTAM Macro Instructions (Part 1 of 5)

Macro Instruction	In-line linkage or code Note 5	Sharable modules		Second level routine	
		Size	Name	Size	Name
ERRMSG	32+ message text	284	IJLQER Note 1	104	IJLQLK
GET Segment	(See Figure 73.)	464	IJLQGS		
Message		482	IJLQGM		
Record		510	IJLQGR		
GET (AUDIO) Audio message	(See Figure 73.)	370	IJLQGA		
Audio and non-audio messages		767	IJLQGB		
Audio message & nonaudio record		792	IJLQGC		
Audio message & nonaudio segment		747	IJLQGD		
INTERCPT	12	128	IJLQIT		
LOGSEG	32	Note 3			
LOGSEG (ARU)	26	304	IJLQLG		
LPSTART	28		Note 1		
MODE (C)	14	48	MODE (U) module & IJLQMM	104	IJLQSH
MODE (U) INITIATE	10	24	IJLQMI		
PRIORITY	10	36	IJLQMP	104	IJLQSH
CONVERSE	10	336	IJLQMC Note 1		
MOD2260	4				
MSGTYPE (C)	19	60	IJLQMT	104	IJLQSH
MSGTYPE (U)	4				
OPCTL	56	3146	IJLQOC	104 104 512	IJLQLK IJLQSH IJLQCL Note 1

Figure 72. Storage Requirements for Other QTAM Macro Instructions (Part 2 of 5)

Macro Instruction	In-line linkage or code Note 5	Sharable modules		Second level routine	
		Size	Name	Size	Name
PAUSE	13 + no. of insert chars.	352	IJLQPZ		Note 1
PCLLIMIT	12	120	IJLQPL		
POSTARU	6	Note 1			
POSTRCV	6		Note 1		
POSTSEND	12		Note 1		
PUT Segment	See Figure 73.	508	IJLQPS		
Message		468	IJLQPM		
Record		532	IJLQPR		
PUT (AUDIO)	See Figure 73.	386	IJLQPA		
RCVHDR	8				
RCVSEG Note 4	0				
RELEASEM	12	161	IJLQRM		
REPEAT	34	Note 1			
REROUTE	26	64	IJLQRR Note 1	104	IJLQLK
RETRIEVE DASD address	14	130	IJLQRD		
By sequence number	26	420	IJLQRS	130	IJLQRD
ROUTE	8	48	IJLQRG	104 104	IJLQLK IJLQSH
SENDHDR	16				
SENDSEG Note 4	4				
SEQIN	8	136	IJLQSI	104	IJLQSH

Figure 72. Storage Requirements for Other QTAM Macro Instructions (Part 3 of 5)

Macro Instruction	In-line linkage or code Note 5	Sharable modules		Second level routine	
		Size	Name	Size	Name
SEQOUT	8	68	IJLQSO	70	IJLQEX
SKIP (CT)	8	48	IJLQST	104	IJLQSH
SKIP (S)	8 + no. to be skipped	76	IJLQSK	104	IJLQSH
SOURCE	8	144	IJLQSR	104	IJLQSH
STARTARU	42	269	IJLQSS	78	IJLQFL
STARTLN	12	512	IJLQCL	78	IJLQFL
STOPARU	42	269	IJLQSS	78	IJLQFL
STOPLN	12	512	IJLQCL	78	IJLQFL
TIMESTMP	8	198	IJLQTS	70	IJLQEX
TRANS	10	114+ 266T	IJLQTR		
WRU	0				

Figure 72. Storage Requirements for other QTAM Macro Instructions (Part 4 of 5)

where:

C = character operand specified (conditional)
U = character operand null (unconditional)
S = skip to and include designated character configuration
CT = skip designated count of nonblank characters
T = number of translation tables

Translation tables are: RCV1030, RCV1050, RCV1050F,
RCV1060, RCV2260, RCV2740, RCV2740F, RCVARU, RCV83B3,
RCV115A, RCVTWX, RCVITA2, RCVZSC3, SND1030, SND1050,
SND1060, SND2260, SNDITA2, SNDZSC3, SND2740, SND83B3,
SND115A, SNTWXE, and SNTWXO

Notes:

1. These delimiters or modules cause linkages to QTAM routines included in Figure 66.
2. If the macro instruction MSGTYPE, ROUTE, or SKIP (S) is used in the program, the storage estimate for IJLQMT, IJLQRG, or IJLQSK, respectively, is not included in the storage estimate for EOA.
3. Because the user defines his own DTFxx and xxMOD macros for his message log file, the size requirements cannot be specified here. Information to determine the storage requirements for the specific logging medium is given under the pertinent DTF and Module, i.e., DTFMT and MTMOD for Tape. Refer to the section IOCS Declarative Macro Instructions.
4. Identifies entry point for RCVSEG and SENDSEG subgroups of LPS.
5. Figure 68 shows the linkage requirement for OPEN, CLOSE, GET, and PUT.

Figure 72. Storage Requirements for Other QTAM Macro Instructions
(Part 5 of 5)

Other IOCS Macro Instructions

Figure 71 lists the main storage requirements for the expansion of the remainder of the IOCS macro instructions.

Macro Instruction Name	NUMBER OF BYTES		
	Basic Storage Requirement	Storage Required For Literals (1)	Variable Requirements
ASMRRTAB	256n		n=number of different operands coded
BTWAIT	16		
CCB	16-24		
CHECK	8	+4	(3)
CHGNTRY	20 (start-stop)		+6 (No operands coded in register notation)
	72 (BSC)		+6 (No operands coded in register notation)
	210 (start-stop Auto Poll)		+72 (No operands coded in register notation)
CHGNTRY	22 (2260 Local)		+4 (No operands coded in register notation)
CHNG (2)	0		
CLOSE	10	+8	+4 per filename parameter, or +8 per register parameter
CLOSER	14 plus 10 if any register parameter is specified	+8	+14 per filename parameter, or +8 per register parameter
CNTRI	10-18	+4	
CONTROL (BTAM)	20		+38 (No operands coded in register notation)
DISEN	8	+4	(3)
DSPLY	24	+4	(3)
ENDFI	8-12	+12	
ESETL	8-12	+4	
EXCP	2-6	0-+4	
FEOV	8-12	+4	
FREE	8-12	0-4	

Figure 73. Other IOCS Macro Instruction Storage Requirements (Part 1 of 4)

Macro Instruction Name	NUMBER OF BYTES		
	Basic Storage Requirement	Storage Required For Literals (1)	Variable Requirements
GET	8	+4 per symbolic name	(3)
LBRET	2		+2
IERB	20		
LITE	8	+4	(3)
LERPRT	14		+8 (No operands coded in register notation)
LOPEN	8		+2 (No operands coded in register notation)
NOTE	12	+4	
OPEN	10	+8	+4 per filename parameter, or +8 per register parameter
OPENR	14 plus 10 if any register parameter is specified	+8	+14 per filename parameter, or +8 per register parameter
POINTR	8	+4 per symbolic name	(3)
POINTS	8-12	+4	
POINTW	8	+4 per symbolic name	(3)
PRTOV	8	+4 per symbolic name	(3)
PUT	8-12	+4 per symbolic name	(3)
RDLNE	12	+4	(3)
READ	8-36	+4 per symbolic name	
READ (BTAM)	20		+38 (No operands coded in register notation)
RELBUF	14		+4 (First operand not coded in register notation)
RELSE	8	+4 per symbolic name	+4

Figure 73. Other IOCS Macro Instruction Storage Requirements (Part 2 of 4)

Macro Instruction Name	NUMBER OF BYTES		
	Basic Storage Requirement	Storage Required For Literals (1)	Variable Requirements
REQBUF	12		+8 (All possible operands not coded in register notation)
RESCN	24	+4	(3)
RESETPL	12		+4 (No operands coded in register notation)
SEOV	10	+8	+3
SETFL	8-12	+12	
SETL	14-22	+8	
TRNSLATE	26		+16 (No operands coded in register notation)
TRSRCTW (BTAM WTTA)	256		
TRSRCT3 (BTAM WTTA)	256		
TRSSCTW (BTAM WTTA)	256		
TRSSCT3 (BTAM WTTA)	256		
TRUNC	8-12	0-+4	
TWAIT	24		+20 (All possible operands not coded in register notation)

Figure 73. Other IOCS Macro Instruction Storage Requirements (Part 3 of 4)

Macro Instruction Name	NUMBER OF BYTES		
	Basic Storage Requirement	Storage Required for Literals (1)	Variable Requirements
WAIT	10-+4	0-+4	
WAIT (BTAM)	16		+20 (No operands coded in register notation)
WAITF	8-12	0-+4	+4 per filename parameter or +8 per register parameter
WRITE	8-26	0-+4	
WRITE (BTAM)	20		+38 (No operands coded in register notation)

Notes:

1. The storage requirement for literals shared by more than one macro instruction should be included for only one macro instruction. For example, EXCP and WAIT share a common CCB name. Other macro instructions can share a common filename.
2. CHNG is provided for Basic Programming Support compatibility.
3. +4 per symbolic name that is specified. +2 per register that is specified in ordinary register notation. +0 per register that is specified in special notation.

Figure 73. Other IOCS Macro Instruction Storage Requirements (Part 4 of 4)

Relocatable Subroutines

This section lists the amounts of main storage required for FORTRAN, Basic FORTRAN, PL/I, and COBOL subroutines when they have been linkage edited into an executable object program. For many FORTRAN, Basic FORTRAN, COBOL, and PL/I main programs or subroutines, several modules are required. Basic FORTRAN programs, for example, require the modules IJTACOM, IJTACON, and IJTFIOS.

The number of blocks (physical records) per routine in the relocatable library is also shown in this section. On a 2311, each track contains nine 322-byte blocks; on a 2314, each track contains sixteen 322-byte blocks. This information is useful in estimating linkage editor times. See Linkage Editor Times discussion in IBM System/360 Disk Operating System, Timing Estimates listed on the front cover of this manual.

COBOL SUBROUTINES

For additional information about these subroutines, see the COBOL Programmer's Guide listed in the Preface of this publication.

<u>Module Name and Alternate Entry Point(s)</u>	<u>Bytes of Main Storage</u>	<u>Number Relocatable Library Blocks (Physical Records)</u>
IHD00000	426	6
IHD00001		
IHD00100	428	3
IHD00101		
IHD00200	142	2
IHD00201		
IHD00300	170	2
IHD00301		
IHD00400	804	6
IHD00401		
IHD00500	436	7
IHD00501		
IHD00600	348	3
IHD00601		
IHD00602		
IHD00700	280	6
IHD00701		
IHD00800	68	4
IHD00801		
IHD00802		
IHD00900	56	4
IHD00901		
IHD01000	53	2
IHD01001		
IHD01100	216	3
IHD01101		
IHD01102		

<u>Module Name and Alternate Entry Point(s)</u>	<u>Bytes of Main Storage</u>	<u>Number Relocatable Library Blocks (Physical Records)</u>
IHD01200	36	4
IHD01201		
IHD01300	56	4
IHD01301		
IHD01400	52	4
IHD01401		
IHD01500	330	3
IHD01501		
IHD01502		
IHD01504		
IHD01600	84	2
IHD01601		
IHD01602		
IHD01700	217	3
IHD01701		
IHD01800	57	2
IHD01801		
IHD01802		
IHD01900	812	8
IHD01901		
IHD01902		
IHD01904		
IHD01908		
IHD02000	358	3
IHD02001		
IHD02002		
IHD02100	178	2
IHD02101		
IHD02200	20	2
IHD02201		
IHD02300	188	2
IHD02301		
IHD02302		
IHD02304		
IHD02400	182	2
IHD02401		
IHD02500	196	2
IHD02501		
IHD02600	64	2
IHD02601		
IHD02700	420	4
IHD02701		
IHD02702		

IHD02800	372	4
IHD02801		
IHD02802		
IHD02900	316	4
IHD02901		
IHD03000	580	5
IHD03001		
IHD03002		
IHD03100	880	5
IHD03102		
IHD03104		
IHD03108		
IHD03200	607	4
IHD03201		
IHD03300	228	3
IHD03301		
IHD03400	630	4
IHD03401		
IHD03500	796	5
IHD03501		
IHD03502		
IHD03600	338	3
IHD03700	691	5
IHD03701		
IHD03702		
IHD03800	1162	7
IHD03801		
IHD03802		
IHD03803		
IHD03804		
IHD03900	781	4
IHD03901		
IHD04000	622	4
IHD04001		
IHD04100	1888	7
IHD04101		

FORTRAN SUBROUTINES

For additional information about these subroutines, see the FORTRAN IV Programmer's Guide listed in the Preface of this manual.

<u>Module Name</u>	<u>Bytes of Main Storage</u>	<u>Number Relocatable Library Blocks (Physical Records)</u>
ILFACOM	1480	8
ILFADCON	4312	20
ILFCLABS	144	3
ILFCLAS	208	3
ILFCLEXP	208	4
ILFCLLOG	224	4
ILFCLSCN	408	5
ILFCLSQT	168	3
ILFCSABS	136	3
ILFCSAS	208	3
ILFCSEXP	208	4
ILFCSLOG	216	4
ILFCSSCN	344	4
ILFCSSQT	168	3
ILFDEBUG	1872	10
ILFDIOCS	584	4
ILFFCDXI	288	3
ILFFCXPI	272	3
ILFFDUMP	472	4
ILFFDVCH	72	3
ILFFDXPD	176	3
ILFFDXPI	168	3
ILFFEXIT	32	2

ILFFINT	1488	9
ILFFIOCS	3032	16
ILFFIXPI	184	3
ILFFMAXD	120	2
ILFFMAXI	224	3
ILFFMAXR	216	3
ILFFOVER	80	2
ILFFRXPI	168	3
ILFFRXPR	168	3
ILFFSLIT	192	3
ILFGHTAB	256	3
ILFIBCOM	3928	19
ILFIBERR	208	3
ILFLASCN	400	4
ILFLATN2	528	5
ILFLERF	800	6
ILFLEXP	480	4
ILFLGAMA	728	5
ILFLLOG	392	4
ILFLSCN	416	4
ILFLSCNH	304	3
ILFLSQRT	160	3
ILFLTANH	312	3
ILFLTNCT	416	3
ILFNAMEL	2224	11
ILFSASCN	312	3
ILFSATN2	384	4
ILFSERF	432	3
ILFSEXP	304	4
ILFSGAMA	488	5
ILFSLOG	288	3
ILFSSCN	304	3
ILFSSCNH	248	3
ILFSSQRT	184	3
ILFSTANH	234	3
ILFSTNCT	320	4
ILFTREK	640	6
ILFUNTAB	256	3

BASIC FORTRAN SUBROUTINES

For additional information about these subroutines, see the Basic FORTRAN IV Programmer's Guide listed in the Preface of this publication.

<u>Module Name</u>	<u>Bytes of Main Storage</u>	<u>Number Relocatable Library Blocks (Physical Records)</u>
IJTAAFR	160	2
IJTACOM	2416	13
IJTACON	2448	12
IJTADIR	1112	8
IJTADXD	200	3

IJTADXI	144	3
IJTAIXI	160	3
IJTAPST	144	3
IJTARBE	928	6
IJTARXI	136	3
IJTARXR	208	3
IJTDVCK	64	2
IJTEXPN	280	3
IJTFDMP	648	6
IJTFIOS	3568	17
IJTFXIT	24	3
IJTHEXC	144	2
IJTIFIX	112	2
IJTLEXP	480	4
IJTLLOG	368	3
IJTLSCN	392	4
IJTLSQT	168	3
IJTLTAN	312	3
IJTLTNH	336	3
IJTMAXD	104	2
IJTMODI	56	2
IJTMODR	104	2
IJTOVRF	80	3
IJTSINT	72	2
IJTSLIT	184	3
IJTSLOG	264	3
IJTSMX0	192	3
IJTSMX1	192	3
IJTSSCN	280	3
IJTSSQT	192	3
IJTSTAN	192	2
IJTSTNH	264	3

PL/I SUBROUTINES

For additional information about these subroutines see the PL/I Programmer's Guide listed in the Preface of this publication.

<u>Module Name</u>	<u>Bytes of Main Storage</u>	<u>Number Relocatable Library Blocks (Physical Records)</u>
IJKEXHC	1200	10
IJKQALM	456	4
IJKQASM	232	4
IJKQBLA	280	3
IJKQBSA	208	3
IJKQCLA	288	3
IJKQCSA	208	3
IJKQDLA	288	3
IJKQDSA	212	3
IJKQLLA	384	4
IJKQLSA	272	3

IJKQNL	608	4
IJKQNSD	480	4
IJKQQLM	160	4
IJKQISM	176	3
IJKQLB	776	5
IJKQRSB	408	3
IJKQSLD	416	4
IJKQSSD	304	3
IJKQTLB	360	3
IJKQTSB	280	3
IJKRBBM	424	4
IJKRBIM	292	4
IJKRBKA	292	3
IJKREBM	92	3
IJKRELM	152	3
IJKREPM	140	3
IJKRESM	144	3
IJKRGIM	108	2
IJKRGKM	84	3
IJKRMBX	278	3
IJKRMLX	172	3
IJKRMPX	386	4
IJKRMSX	132	3
IJKRSEM	200	3
IJKRSLM	192	3
IJKRSPM	265	3
IJKRSSM	184	3
IJKRUBM	148	3
IJKRWBM	356	4
IJKRWLM	244	3
IJKRWPM	577	5
IJKRWSM	236	3
IJKRXLM	168	3
IJKRXSA	152	3
IJKSDMP	56	2
IJKSDTM	58	2
IJKSTMM	104	2
IJKSYSA	201	3
IJKSYSI	152	3
IJKSZBA	1772	8
IJKSZCA	1636	8
IJKSZLM	60	3
IJKTCBM	550	4
IJKTCUM	252	3
IJKTDPD	184	3
IJKTDIM	540	4
IJKTFDM	480	4
IJKTFMM	196	3
IJKTGDI	414	4
IJKTLCM	876	5
IJKTLIM	1158	7
IJKTLOM	1076	7
IJKTLTB	7	2
IJKTPSM	72	3

IJKTRGM	398	4
IJKTRON	1372	8
IJKTSIM	652	5
IJKTSTM	674	5
IJKTXCF	120	2
IJKTXRM	356	3
IJKTXRN	378	3
IJKVBCM	60	3
IJKVBTM	132	3
IJKVCBM	238	3
IJKVCEM	984	6
IJKVCFM	680	5
IJKVCPM	214	3
IJKVCTM	392	4
IJKVECM	404	4
IJKVFCM	492	4
IJKVGIM	236	3
IJKVIGM	148	3
IJKVIIM	180	3
IJKVNPM	324	4
IJKVPCM	68	3
IJKVPM	316	4
IJKVPRM	1196	7
IJKVRPM	796	5
IJKVTBM	228	4
IJKVTCM	284	4
IJKXTBM	128	2
IJXSYSA	305	3
IJXSYSI	224	3

IOCS Modules for the Compilers

These modules are described in Appendix B of this publication.

<u>COBOL Module</u>	<u>Module Name</u>	<u>Bytes of Main Storage</u>	<u>Number Relocatable Library Blocks (Physical Records)</u>
CDMOD (Card Modules)	IJCFZIZ0	96	2
	IJCFZIZ1	100	2
	IJCFZIZ2	96	2
	IJCFZIZ3	96	2
	IJCFAOZ0	92	2
	IJCFAOZ1	128	2
	IJCFAOZ2	132	2
	IJCFAOZ4	248	3
	IJCFAOZ5	224	3
	IJCFZOZ1	74	2
	IJCFZOZ2	80	2
	IJCFZOZ4	208	3
	IJCFZOZ5	192	3
	IJCFZII0	128	2
	IJCFZII1	132	2
	IJCFZII2	128	2
	IJCFZII3	128	2

IJCFAOI0	116	2
IJCFAOI1	152	2
IJCFAOI2	156	2
IJCFAOI4	264	3
IJCFAOI5	248	3
IJCFZOI1	116	2
IJCFZOI2	124	2
IJCFZOI4	232	3
IJCFZOI5	216	3

Note:

The last character in each module name identifies the card device:

- 0 = 2540 (input only)
- 1 = 1442
- 2 = 2520
- 3 = 2501
- 4 = 2540 when CRDERR=RETRY is specified.

PRMOD (Printer Module)	IJDFAPIZ	280	3
	IJDFAPZZ	268	2
	IJDFZPIZ	152	2
	IJDFZPZZ	118	2
MTMOD (Magnetic Tape Modules)	IJFFBCZZ	894	6
	IJFUBCZZ	848	5
	IJFVBCWZ	1274	6
	IJFVBCZZ	1138	6
SDMOD (Sequential DASD Modules)	IJGFIEZZ	614	4
	IJGFIZZZ	470	3
	IJGFOZZZ	554	3
	IJGFUZZZ	806	4
	IJGUIZZZ	641	4
	IJGUIZZZ	541	3
	IJGUOZZZ	671	4
	IJGUZZZ	953	5
	IJGVIEZZ	741	4
	IJGVIZZZ	637	4
	IJGVOZZZ	1077	5
	IJGVUZZZ	1094	6
DAMOD (Direct Access Module)	IJIBAIZZ	1064	5
	IJIBAZZZ	864	4
	IJIBZIZZ	848	4
	IJIBZZZZ	648	4
	IJIFAIZZ	988	5
	IJIFAZZZ	794	4
	IJIFZIZZ	648	4
	IJIFZZZZ	492	3
ISMOD (Indexed Sequential DASD Module)	IJHAABZZ	4524	19
	IJHAARCP	4334	19
	IJHAARCZ	3966	18
	IJHAARZP	4062	17
	IJHAARZZ	3684	16
	IJHAASZZ	3888	16
	IJHAIZZZ	3040	13
	IJHBABZZ	4280	18
	IJHBARCP	4090	18
	IJHBARCZ	3718	16

IJHBARZP	3820	17
IJHBARZZ	3440	15
IJHBASZZ	3642	15
IJHBIZZZ	2794	12
IJHUABZZ	4064	17
IJHUARCP	3822	17
IJHUARCZ	3506	15
IJHUARZP	3540	15
IJHUARZZ	3224	14
IJHUASZZ	3428	15
IJHUIZZZ	2584	11
IJHZLZZZ	811	4
IJHZRBZZ	2124	10
IJHZRRCZ	1460	8
IJHZRRZZ	1290	7
IJHZRSZZ	1268	7

<u>PL/I Module</u>	<u>Module Name</u>	<u>Bytes of Main Storage</u>	<u>Number</u>	
			<u>Relocatable Library Blocks (Physical Records)</u>	
CDMOD (Card Modules)	IJCFAOI1	152	2	
	IJCFAOI2	156	2	
	IJCFAOI4	264	3	
	IJCFAOZ1	128	2	
	IJCFAOZ2	132	2	
	IJCFAOZ4	248	3	
	IJCFYOI1	132	2	
	IJCFYOI2	136	2	
	IJCFYOI4	248	3	
	IJCFYOZ1	108	2	
	IJCFYOZ2	112	2	
	IJCFYOZ4	224	3	
	IJCFZIZ0	96	2	
	IJCFZIZ1	100	2	
	IJCFZIZ2	96	2	
	IJCFZIZ3	96	2	
	IJCFZII0	128	2	
	IJCFZII1	132	2	
	IJCFZII2	128	2	
	IJCFZII3	128	2	
	IJCFZOZ1	74	2	
	IJCFZOZ2	80	2	
	IJCFZOZ4	208	3	
	IJCFZOI1	116	2	
	IJCFZOI2	124	2	
	IJCFZOI4	232	3	

Note: The last character in each module name identifies the card device:

- 0 = 2540 (input only)
- 1 = 1442
- 2 = 2520
- 3 = 2501
- 4 = 2540 when CRDERR=RETRY is specified.

PRMOD (Printer Modules)	IJDFAZIZ	220	2	
	IJDFAZZZ	196	2	
	IJDFYZIZ	96	2	
	IJDFYZZZ	72	2	
	IJDFZPIZ	152	2	
	IJDFZPZZ	118	2	
MTMOD (Magnetic Tape Modules)	IJFFBZZZ	894	5	
	IJFFZZZZ	846	5	
	IJFUBZZZ	680	4	
	IJFUZZZZ	672	4	
	IJFVZZZZ	890	5	
SDMOD (Sequential DASD Modules)	IJGFIETZ	742	4	
	IJGFIEZZ	614	4	
	IJGFOEZZ	618	4	
	IJGFUEZZ	970	5	
	IJGUIEZZ	641	4	
	IJGUOEZZ	729	4	
	IJGUUEZZ	1101	6	
	IJGVIEZZ	741	4	
	IJGVOEZZ	1145	6	
	IJGVUEZZ	1270	6	
	DAMOD (Direct Access Modules)	IJIFAZZZ	794	4
		IJIFZZZZ	492	3
ISMOD (Indexed Sequential DASD Modules)	IJHAARCP	4334	19	
	IJHAARCZ	3966	18	
	IJHAARZP	4062	17	
	IJHAARZZ	3684	16	
	IJHBARCP	4090	18	
	IJHBARCZ	3718	16	
	IJHBARZP	3812	17	
	IJHBARZZ	3440	15	
	IJHUARCP	3822	17	
	IJHUARCZ	3506	15	
	IJHUARZP	3540	15	
	IJHUARZZ	3224	14	
	IJHZLZZZ	811	4	
	IJHZRRCZ	1460	8	
	IJHZRRZZ	1290	7	
	IJHZRSZZ	1268	7	
	DIMOD (Device Independent Modules)	IJJFCBID	747	4
		IJJFCBZD	668	4
		IJJFCIID	368	3
		IJJFCIZD	308	3

<u>RPG Modules</u>	<u>Module Name</u>	<u>Bytes of Main Storage</u>	<u>Number</u>
			<u>Relocatable Library Blocks (Physical Records)</u>
CDMOD (Card Modules)	IJCFCCZ0	218	2
	IJCFCCZ1	132	2
	IJCFCCZ2	218	2

IJCFCI20	158	2
IJCFCI21	124	2
IJCFCI22	142	2
IJCFYO10	96	2
IJCFYO11	132	2
IJCFYO12	136	2
IJCFYO20	72	2
IJCFYO21	108	2
IJCFYO22	112	2
IJCFZ110	128	2
IJCFZ111	132	2
IJCFZ112	128	2
IJCFZ113	128	2
IJCFZ123	96	2

Note: The last character in the module name indicates the card device:

0 = 2540
 1 = 1442
 2 = 2520
 3 = 2501

PRMOD (Printer Module)	IJDFYPZZ	138	2
MTMOD (Magnetic Tape Modules)	IJFFZCZZ IJFVZCWZ	1046 1200	6 6
DAMOD (Direct Access Module)	IJIBZZZZ	648	4
ISMOD (Indexed Sequential Modules)	IJHZRBZZ IJHZRRZZ IJHZRSZZ	2124 1290 1268	10 7 7
SDMOD (Sequential DASD Modules)	IJGFIZZZ IJGFUZZZ IJGFOZZZ IJGVIZZZ IJGVUZZZ IJGVOZZZ	470 806 554 637 1094 1077	3 4 4 4 6 5

<u>Other Modules Required for the System</u>	<u>Module Name</u>	<u>Bytes of Main Storage</u>	<u>Number Relocatable Library Blocks (Physical Records)</u>
Tape Work File Modules	IJFWEZZZ IJFWZNZZ IJFWZZZZ	322 450 232	3 3 2
Disk Work File Modules	IJGWEZZZ IJGWZNZZ IJGWZRZZ	728 800 738	4 4 4

Nondevice	IJJCP0	363	3
Dependent	IJJCP1	285	3
IOCS Modules	IJJCP2	108	2
Used by IBM Processor Programs	IJJCP3	38	2
	IJJCPD0	521	3
	IJJCPD1	451	3
	IJJCPD2	252	2
	IJJCPD3	176	2
	IJJCPDV	483	3
	IJJCPDV2	184	2
	IJJCPV	317	3
	IJJCPV2	48	2
	IJJCPV1	245	2
	IJJCP1N	213	2
	IJJCP0N	291	3

	IJJCPDV1	427	3
	IJJCPD1N	395	3
	IJJCPD0N	465	3

BTAM Modules	Module Name	Bytes of Main Storage	Number
			Relocatable Library Blocks (Physical Records)
	IJL0AY	78	2
BTAM	IJL0EZ	88	2
Channel	IJL00Y	52	2
Program	IJL01Z	107	2
Modules (For	IJL01J	155	2
start-stop,	IJL02Z	95	2
the modules	IJL02J	143	2
include a			
Table of	IJL03Z	156	2
Special	IJL04Z	46	2
Characters)	IJL05Z	40	2
	IJL07Z	84	2
	IJL07J	100	2
	IJL07Y	170	2
	IJL08Z	45	2
	IJL08X	60	2
	IJL08H	65	2
	IJL08P	108	2
	IJL089	113	2
	IJL08M	152	2
	IJL08R	101	2
	IJL08Q	132	2
	IJL08U	90	2
	IJL08Y	70	2
	IJL09Y	74	2
	IJL10Y	52	2
	IJL@06Z	16	1
BTAM WTTA Subroutine	IJLWTZ	1031	6

<u>BTAM Modules</u>	<u>Module Name</u>	<u>Bytes of Main Storage</u>	<u>Number Relocatable Library Blocks (Physical Records)</u>
BTAM Channel Program Modules for BSC	IJL0BZ	240	3
	IJL0BY	296	3
	IJL0BA	300	3
	IJL0BC	324	3
	IJL0BE	300	3
	IJL0BG	324	3
	IJL0BI	300	3
	IJL0BK	320	3
	IJL0BM	296	3
	IJL0BO	320	3
	IJL0BQ	296	3
	IJL0BS	320	3
	IJL0BU	296	3
	IJL0BW	320	3
	IJL0B4	324	3
	IJL0B6	300	3
	IJL0B8	324	3
	IJL0CY	196	2
	IJL0CZ	148	2
	IJL0DY	140	2
	IJL0DZ	96	2
	IJL1BZ	220	2
	IJL1CZ	164	2
IJL1DZ	132	2	
IJL2DZ	84	2	
BSC Tables of Special Characters	IJLEBD	53	2
	IJLASC	53	2
	IJLTCD	53	2

	<u>Module Name</u>	<u>Bytes of Main Storage</u>	<u>Number Relocatable Library Blocks (Physical Records)</u>
BTAM	IJLRASA	256	2
Translation	IJLRCTW	256	2
Tables	IJLRCT1	256	2
	IJLRCT2	256	2
	IJLRCT3	256	2
	IJLRC30	256	2
	IJLRC40	256	2
	IJLRC50	256	2
	IJLRC60	256	2
	IJLRC80	256	2
	IJLRF40	256	2
	IJLRF50	256	2
	IJLRSCI	256	2
	IJLSASA	256	2
	IJLSCTW	256	2
	IJLSCT1	256	2
	IJLSCT2	256	2
	IJLSCT3	256	2
	IJLSD30	256	2
	IJLSD40	256	2
	IJLSD50	256	2
	IJLSD60	256	2
	IJLSD80	256	2
	IJLSSCI	256	2

External Storage Requirements

This section discusses the residence requirement for each IBM-supplied component in a system pack. The overall organization of the system pack is as follows:

<u>Name</u>	<u>Start Location, if Present</u>
IPL Program	Track 0 of Cylinder 0.
System Volume Label	Track 0 of Cylinder 0.
System Directory	Track 1 of Cylinder 0.
Librarian Work Area	Tracks 2, 3, and 4 of Cylinder 0.
Transient Directory	Track 5 of Cylinder 0.
Open Routine Directory	Track 6 of Cylinder 0.
Library Routine Directory	Track 7 of Cylinder 0.
Foreground Program Directory	Track 8 of Cylinder 0.
Problem Program Phase Directory	Track 9 of Cylinder 0.
Core Image Directory	Track 0 of Cylinder 1, on a 2311; track 10 of Cylinder 0 on a 2314.

Core Image Library	Beginning of the first available track following the core image directory.
Relocatable Directory, Optional	Track 0 of the first available cylinder following the core image library.
Relocatable Library, Optional	Beginning of the first available track following the relocatable directory.
Source Statement Directory, Optional	Track 0 of the first available cylinder following the previous library.
Source Statement Library Optional	Beginning of the first available track following the source statement directory.
Label Cylinder	First full cylinder after the last system library.

<u>Track</u>	<u>Provides Storage For</u>
0	Background User Labels
1	Background PARSTD Labels
2	Foreground 2 User Labels
3	Foreground 2 PARSTD Labels
4	Foreground 1 User Labels
5	Foreground 1 PARSTD Labels
6 - 9	Standard Labels (2311)
or	
6 - 19	Standard Labels (2314)

Volume Table of Contents (VTOC)	Location assigned by the user.
------------------------------------	--------------------------------

Directory Entries: Each track in the core image directory can contain entries for 144 phases on the 2311 and 270 phases on the 2314. Each track in the relocatable directory can contain entries for 180 modules on the 2311 and 340 modules on the 2314. Each track in the source statement directory can contain entries for 160 books on the 2311, and 270 books on the 2314. However, the first track in both the relocatable and the source statement directories can contain five fewer entries.

Library Block Lengths: In the core image library on a 2311, each track contains two 1728-byte blocks; on a 2314, each track contains four 1688-byte blocks. In the relocatable library on a 2311, each track contains nine 322-byte blocks; on a 2314, each track contains sixteen 322-byte blocks. In the source statement library on a 2311, each track contains sixteen 160-byte blocks; on a 2314, each track contains twenty-seven 160-byte blocks.

Core Image Library

<u>Component</u>	<u>Number of Library Blocks (Physical Records)</u>	
	<u>2311</u>	<u>2314</u>
Supervisor Nucleus (6K)	4	-
Supervisor Nucleus (8K)	5	5
All Other Transient Functions ¹	202	200
Job Control	20	20
Linkage Editor	14	15
IPL	4	4
CSERV	5	5
DSERV	5	5
RSERV	4	4
SSERV	4	4
MAINT	32	32
CORGZ	17	17
Assembler	87	87
Assembler F	69	69
Autotest	58	-
COBOL	171	173
COBOL Debug	4	4
FORTTRAN	42	42
Basic FORTTRAN	20	20
PL/I	264	268
RPG	98	101

Tape Sort	36	36
Disk Sort	74	76
Tape and Disk Sort	69	70
CE Serviceability Programs	14	14
Utilities:		
Card-to-Disk	10	10
Card-to-Printer and/or Punch	12	12
Card-to-Tape	10	10
Clear Data Cell	4	4
Clear Disk	4	4
Data Cell to Data Cell	11	11
Data Cell to Disk	11	11
Data Cell to Printer	12	12
Data Cell to Tape	10	10
Disk-to-Card	11	11
Disk to Data Cell	11	11
Disk-to-Disk	11	11
Disk-to-Printer	12	12
Disk-to-Tape	10	10
Tape-Compare	5	5
Tape-to-Card	11	11
Tape to Data Cell	11	11
Tape-to-Disk	11	11
Tape-to-Printer	11	12
Tape-to-Tape	10	10
VTOC Display	3	3
Copy Disk-to-Disk	7	7
Copy Disk or Data Cell-to-Tape	7	7
Copy Disk-to-Card	7	7
Restore Tape-to-Disk or Data Cell	4	4
Restore Card-to-Disk	4	4
Initialize Disk	14	14
Alternate Track Assignment Disk	25	26
Initialize Data Cell	9	10
Alternate Track Assignment Data Cell	20	20
OLTEP ²	16	16
Vocabulary File Utility	19	19
BTAM Transient Routines	20	20
QTAM Transient Routines	22	22

Notes:

1. All transient functions not specifically listed are grouped together.
2. If the OLTEP Tape-Gap timing program is run in a multiprogramming environment, the performance of any foreground program may be affected.

Relocatable Library

<u>Component</u>	<u>Number of Library Blocks (Physical Records)</u>
System Control	790
Job Control	
Linkage Editor	
CSERV	
DSERV	
RSERV	
SSERV	
IPL	
CORGZ	
MAINT	
Standard System Dump	
Translating System Dump	
Assembler	604
Assembler F	475
Autotest	358
COBOL	1342
COBOL Subroutines	161
COBOL Debug	23
FORTRAN	300
FORTRAN Subroutines	279
Basic FORTRAN	140
Basic FORTRAN Subroutines	148
PL/I	2252
PL/I Subroutines	342
RPG	782
Tape Sort	204
Tape and Disk Sort	974
Disk Sort	518
CE Serviceability Programs	51
Utilities (3 Groups)	
Group 1	666
Group 2	432
Group 3	230
OLTEP ¹	144
Vocakulary File Utility	139
BTAM Modules	179
QTAM Modules	394
Compiler IOCS Modules	
COBOL	546
PL/I	384
RPG	102
Non-Device Dependent	46

¹ If the OLTEP Tape-Gap timing test program is run in a multiprogramming environment, the performance of any foreground program may be affected.

Source Statement Library

File Definition <u>Macros</u>	Number of Library <u>Blocks</u>
A.CDMOD	197
A.DAMOD	188
A.DIMOD	140
A.DTFBG	2
A.DTFCD	108
A.DTFCN	73
A.DTFDA	198
A.DTFDI	61
A.DTFEN	24
A.DTFIS	7
A.DTFMR	72
A.DTFMT	165
A.DTFOR	91
A.DTFPH	51
A.DTFPR	56
A.DTFPT	111
A.DTFSD	197
A.DTFSR	62
A.ISMOD	4
A.MRMOD	102
A.MTMOD	620
A.ORMOD	421
A.PRMOD	95
A.PTMOD	206
A.SDMOD	120
A.SDMODFI	193
A.SDMODFO	196
A.SDMODFU	301
A.SDMODVI	115
A.SDMODVO	144
A.SDMODVU	197
A.SDMODUI	103
A.SDMODUO	114
A.SDMODUU	174
A.SDMODW	275
A.DTFIS1	62
A.DTFIS2	66
A.DTFIS3	53
A.ISMOD0	94
A.ISMOD1	193
A.ISMOD2	155
A.ISMOD3	116
A.ISMOD4	113
A.ISMOD5	114
A.ISMOD6	195
A.ISMOD7	130
A.ISMOD8	111
A.ISMOD9	165
Total	<u>6,750</u>

Supervisor Communications <u>Macros</u>	Number of Library <u>Blocks</u>
A.ATTACH	11
A.CALL	10
A.CANCEL	4
A.CHKPT	23
A.CHNG	2
A.COMRG	2
A.DEQ	5
A.DETACH	4
A.DUMP	2
A.ENQ	4
A.EOJ	2
A.EXIT	5
A.FETCH	6
A.GETIME	9
A.LOAD	6
A.MVCOM	7
A.PDUMP	7
A.POST	6
A.RCB	2
A.RETURN	11
A.SAVE	10
A.SETIME	8
A.STXIT	9
A.TECB	2
A.WAITM	8
Total	<u>165</u>

<u>BTAM Macros</u>	Number of Library <u>Blocks</u>
A.ASMTRTAB	3
A.BTMOD	2313
A.DFTRMLST	82
A.DTFBT	186
A.DTFBTND	2
A.IJLBTMDS	60
A.TRNSLATE	48
A.CONTROL	3
A.CHGNTRY	107
A.BTWAIT	37
A.LERB	30
A.BTRWC	149
A.LERPRT	35
A.LOPEN	9
A.RELBUF	19
A.REQBUF	29
A.RESETPL	11
A.TWAIT	27
A.ONLTST	50
A.TRSRCTW	20
A.TRSRCT3	20
A.TRSSCTW	24
A.TRSSCT3	24
Total	<u>3,387</u>

<u>IOCS Imperative Macros</u>	<u>Number of Library Blocks</u>	<u>Supervisor Generation Macros</u>	<u>Number of Library Blocks</u>
A.OPENR	13	A.ALLOC	22
A.POINTR	9	A.ASSGN	14
A.POINTS	6	A.COMMN	46
A.POINTW	9	A.CONFG	17
A.PRTOV	10	A.DVCGEN	42
A.PUT	12	A.FOFT	211
A.RDLNE	6	A.IJLQBFRD	29
A.READ	30	A.IJLQDSCT	2
A.RELSE	6	A.IJLQIP1D	4
A.RESCN	12	A.IJLQQCBD	26
A.SEOV	4	A.IJLQSTBD	4
		A.IJLQTSVC	104
		A.IJLQVECD	12
A.SETFL	5	A.IOTAB	146
A.SETI	9	A.LUBGEN	19
A.TRUNC	6	A.PIOCS	24
A.WAIT	5	A.SEND	191
A.WAITF	17	A.SGDFCH	96
A.WRITE	33		
Total	335	A.SGDSK	49
		A.SGSVC	260
		A.SGTCHS	332
		A.SGTCON	126
		A.SGTHAP	295
		A.SGUNCK	91
		A.SMICR	209
		A.STDJC	22
		A.SUPVR	44
		Total	2,438
<u>COBOL and PL/I DASD Macros</u>	<u>Number of Library Blocks</u>	<u>Maintenance Macro</u>	<u>Number of Library Blocks</u>
A.LOADA	28	A.DOSCHLV	59
A.LODIS*	30	Z.ILFMERGE	11
A.RANDA	28	Z.DELETECL	17
A.RUADA	44	Z.DELETERL	41
		Z.DELETESL	38
A.RRUIS*	32	Z.LINKEDIT	114
A.RUAIS*	40	Total	280
A.SEQDA	30		
A.SRUIS*	38		
Total	270		
*Used by PL/I			
<u>PL/I Macro</u>	<u>Number of Library Blocks</u>		
A.IJKZL	6		
<u>MPS Utility Macros</u>	<u>Number of Library Blocks</u>	<u>IBM Model 30 Emulator Macros</u>	<u>Number of Library Blocks</u>
A.INCARD	37	A.EU3CG	106
A.INDISK	124	A.EU3DK	727
A.INLOG	39	A.EU3EJ	61
A.INTAPE	146	A.EU3ER	30
A.INPCR	296	A.EU3FT	37
A.OUTCARD	91	A.EU3MS	66
		A.EU3OS	669
A.OUTDISK	170	A.EU3PH	239
A.OUTLOG	39	A.EU3PT	171
A.OUTPUT	110	A.EU3RD	235
A.OUTPUT	110	A.EU3TP	306
A.OUTPUT	110	A.EU30	859
Total	1,180	Total	3,562

<u>Sample Problems</u>	<u>Number of Library Blocks</u>	<u>IBM Model 40 Emulator Macros</u>	<u>Number of Library Blocks</u>
Z.AS1	6	A. DIAG	19
Z.AS2	6	A. EU4CG	60
Z.AS3	6	A. EU4DK	689
Z.AS4	6	A. EU4EJ	85
Z.AS5	6	A. EU4ER	43
Z.AS6	6	A. EU4FT	17
Z.AT1	6	A. EU4IN	253
Z.CB1	25	A. EU4MS	36
Z.EU3SPRGM	88	A. EU4OS	656
Z.EU4SPRGM	88	A. EU4PH	248
Z.FO1	5	A. EU4PT	183
Z.IIFSAMPL	5	A. EU4RD	241
Z.MCR1	18	A. EU4TP	317
Z.MCR2	30	A. EU40	1047
Z.ORDC	45		
Z.ORJT	21		
Z.PI1	11		
Z.RG1	13		
Z.SM1	2		
Z.SM2	2		
Z.SM4	2		
Z.SM5	2		
Z.SM6	2		
Z.UTDCPR1	1		
Z.UTDKPR1	1		
Z.UTDKPR2	1		
Z.UTDKPR3	1		
Z.UTTPPR1	1		
Z.UTTPPR2	1		
Z.VFU1	17		
Z.IIFSAMPL	5		
	<u>5</u>		
	Total 338		Total 3,894

Workfile Requirements

This section contains information for determining the workfile requirements for the Linkage Editor, Assembler F, Assembler, COBOL, FORTRAN, Basic FORTRAN, PL/I, and RPG.

WORKFILE REQUIREMENTS FOR LINKAGE EDITOR AND ASSEMBLER (IBM 2311 AND IBM 2314)

This section contains information for determining the workfile requirements for the Linkage Editor and Assembler when the workfile is on an IBM 2311 or 2314.

Two workfiles are used by the Linkage Editor: SYSLNK for input, and SYS001 for a workfile.

The best overall performance for linkage editing results from using two disks and one tape: SYSRES and SYSLNK each assigned to a separate disk drive, and SYS001 assigned to tape. When possible, SYSLNK should be assigned to the faster of the two disks because more I/O is performed on SYSLNK than on SYSRES. Because linkage editing time is relatively small compared to assembler or compiler times, optimum assignments for assembling and linkage editing (or compiling and linkage editing) should be based on assembler or compiler conditions, not linkage edit time. Thus, when making optimum workfile assignments, the major consideration should be compiler time. A savings in linkage editing time is generally at the expense of compiler performance.

When built by a language processor, SYSLNK contains 25 card images per track. When an object deck is used as input to the Linkage Editor, job control formats SYSLNK. In this case, SYSLNK contains 9-36 card images per track; ESD, TXT, and RLD cards are packed 4 per record while all other input cards are not packed (1 per record).

In a compile and linkage edit situation, any allocation made for SYS001 for the compilation is more than sufficient as a workfile allocation for the Linkage Editor. However, when the programmer must allocate SYS001, he can use this information. The Linkage Editor workfile (SYS001) contains 10 records per track. The total number of records (R) required for linkage editing a program is equal to the following:

$$R = 1 + \frac{x_1}{4} + \frac{x_2}{4} + \dots + \frac{x_n}{4}$$

where r_1 = rounded high

x_1, x_2, \dots, x_n = number of RLD cards in each module to be processed by the Linkage Editor

ASSEMBLER WORKFILES

The Assembler workfile requirements can be determined by adding the appropriate track values from Figure 75 or Figure 76 to the appropriate track values determined from Figure 74. Note that Figure 74 is expressed in terms of number of bytes. The approximate number of tracks can be calculated by dividing the number of bytes by 3000 for a 2311

file or by 6000 for a 2314 file. These numbers represent the approximate number of text bytes per track for a 2311 and a 2314, respectively. In Figures 75 and 76 SYSLNK requirements are expressed in terms of tracks per macro instruction; the other three areas are expressed in tracks per macro definition.

In determining the total number of tracks required for Assembler workfiles, the SYSLNK value must be included each time the macro instruction is used. The SYS001, SYS002, and SYS003 values need be included only once per macro definition, regardless of the number of times the macro instruction is used.

For example, if three tape files are defined, three DTFMT macros are used. The track values for SYS001, SYS002, SYS003 are included once because the Assembler uses macro definition only once; but the SYSLNK value is multiplied by three because the macro instruction is expanded three times.

		Number of Bytes			
		<u>SYSLNK</u> Bytes per Statement	<u>SYS001</u> Bytes per Statement	<u>SYS002</u> Bytes per Statement	<u>SYS003</u> Bytes per Statement
IJQD16TW	1 for 1 Statements	15	150	150	36
IJQD16DW					
IJQD32 IJYASM		15	130	130	36

Figure 74. Non-Macro Assembly Workfile Requirements for 2311 and 2314

	Number of Tracks							
	SYSLNK Tracks per Macro Inst.		SYS001 Tracks per Macro Def.		SYS002 Tracks per Macro Def.		SYS003 Tracks per Macro Def.	
	2311	2314	2311	2314	2311	2314	2311	2314
Short Macros like IOCS Imperatives	0.02	0.13	1	1	2	1	1	1
CDMOD	0.15	0.09	11	6	3	7	17	8
DAMOD	0.38	0.24	10	5	13	7	9	4
DIMOD	0.55	0.35	8	4	11	6	11	5
DTFCD	0.05	0.03	6	3	7	4	9	4
DTFCN	0.08	0.05	4	2	5	3	6	3
DTFDA	0.08	0.05	9	5	10	6	13	6
DTFDI	0.36	0.23	4	2	4	2	5	2
*DTFEN	0	0	127	67	143	75	162	84
DTFIS	0.12	0.08	9	5	11	6	13	6
DTFMR	0.34	0.17	4	2	5	3	5	3
DTFMT	0.05	0.03	9	5	10	5	12	6
DTFOR	0.08	0.05	4	2	4	2	5	2
DTFPH	0.08	0.05	3	2	4	2	5	2
DTFPR	0.05	0.03	3	2	4	2	5	2
DTFPT	0.05	0.03	7	4	8	4	9	4
DTFSD	0.08	0.05	10	5	11	6	13	7
DTFSR	0.08	0.05	79	41	90	47	105	54
ISMOD	0.74	0.47	53	28	64	33	58	30

Figure 75. Assembler Macro Instruction Workfile Requirements for the IBM 2311 and IBM 2314 (Part 1 of 2)

	Number of Tracks							
	SYSLNK Tracks per Macro Inst.		SYS001 Tracks per Macrd Def.		SYS002 Tracks per Macro Def.		SYS003 Tracks per Macro Def.	
	2311	2314	2311	2314	2311	2314	2311	2314
MRMOD	0.67	0.34	10	5	12	6	8	4
MTMOD	0.23	0.15	22	12	23	12	27	14
ORMOD	0.20	0.13	11	6	16	8	15	7
PRMOD	0.12	0.08	5	3	6	4	8	4
PTMOD	0.15	0.09	13	7	13	7	14	7
SDMODFI	0.80	0.50	12	6	14	8	16	8
SDMODFO	0.80	0.50	12	7	15	8	16	8
SDMODFU	0.80	0.50	15	8	18	10	19	9
SDMODVI	0.80	0.50	11	6	12	6	14	7
SDMODVO	0.80	0.50	13	7	16	9	16	8
SDMODVU	0.80	0.50	13	7	17	9	16	8
SDMODUI	0.80	0.50	10	5	11	6	13	7
SDMODUO	0.80	0.50	11	6	12	6	14	7
SDMODUU	0.80	0.50	13	7	15	8	16	8
SDMODW	0.80	0.50	16	9	17	9	22	11

* The measurements for DTFEN, unlike the other macro instruction measurements, represent minimum workfile requirements. The measurements were made assembling DTFEN by itself, which resulted in minimum expansion. The use of DTFEN should be avoided wherever possible because of its large workfile requirements.

Figure 75. Assembler Macro Instruction Workfile Requirements for the IBM 2311 and IBM 2314 (Part 2 of 2)

	Number of Tracks							
	SYSLNK Tracks per Macro Inst.	SYS001 Tracks per Macro Def.		SYS002 Tracks per Macro Def.		SYS003 Tracks per Macro Def.		
		2311 and 2314	2311	2314	2311	2314	2311	2314
Short Macros like IOCS Imperatives	0.02	1	1	1	1	2	1	
CDMOD	0.15	2	2	2	1	10	5	
DAMOD	0.38	5	3	5	3	6	4	
DIMOD	0.55	5	3	5	3	7	4	
DTFCD	0.05	2	1	2	1	5	3	
DTFCN	0.08	2	1	2	1	4	3	
DTFDA	0.08	3	2	3	2	7	4	
DTFDI	0.36	2	1	2	1	4	3	
*DTFEN	0	2	1	2	1	121	62	
DTFIS	0.12	3	2	3	2	7	4	
DTFMR	0.34	2	1	2	1	4	3	
DTFMT	0.05	2	1	3	2	7	4	
DTFOR	0.08	2	1	1	1	3	2	
DTFPH	0.08	1	1	1	1	3	2	
DTFPR	0.05	2	1	1	1	3	2	
DTFPT	0.05	2	1	2	1	6	3	
DTFSD	0.08	2	1	3	2	8	4	
DTFSR	0.08	2	1	3	2	70	38	
ISMOD	0.74	18	17	15	15	26	25	
MRMOD	0.67	5	3	4	2	7	4	

Figure 76. Assembler F Macro Instruction Workfile Requirements for the IBM 2311 and IBM 2314 (Part 1 of 2)

	Number of Tracks						
	SYSLNK Tracks per Macro Inst.	SYS001 Tracks per Macro Def.		SYS002 Tracks per Macro Def.		SYS003 Tracks per Macro Def.	
		2311 and 2314	2311	2314	2311	2314	2311
MTMOD	0.23	6	3	5	3	20	11
ORMOD	0.20	3	4	3	4	7	6
PRMOD	0.12	3	2	2	1	5	3
PTMOD	0.15	4	2	3	2	12	7
READ, WRITE	0.02	1	1	1	1	2	1
SDMODFI	0.80	4	3	4	2	12	6
SDMODFO	0.80	5	3	4	2	12	7
SDMODFU	0.80	6	3	5	3	15	8
SDMODVI	0.80	5	3	5	3	10	5
SDMODVO	0.80	7	4	6	3	12	6
SDMODVU	0.80	7	4	6	4	12	7
SDMODUI	0.80	5	3	4	2	9	5
SDMODUO	0.80	5	3	4	3	10	5
SDMODUU	0.80	7	4	6	3	12	6
SDMODW	0.80	6	4	6	3	13	7

* The measurements for DTFEN, unlike the other macro instruction measurements, represent minimum workfile requirements. The measurements were made assembling DTFEN by itself, which resulted in minimum expansion. The use of DTFEN should be avoided wherever possible because of its large workfile requirements.

Figure 76. Assembler F Macro Instruction Workfile Requirements for the IBM 2311 and IBM 2314 (Part 2 of 2)

IBM 2311 Workfile Requirements

This section contains information for determining the workfile requirements for Autotest, COBOL, FORTRAN, Basic FORTRAN PL/I and RPG when the workfile is on an IBM 2311.

AUTOTEST WORK AREA (IBM 2311)

To autotest a program with no symbols and with no test requests, the minimum work area (IJSYSAT) for machine sizes of 32K or higher requires 11 tracks. For machine sizes less than 32K, 6 tracks are required. A complete description of this work area, including formulas to calculate the required number of tracks for a specific program, is included in the Autotest publication.

COBOL WORKFILES (IBM 2311)

Although the amount of COBOL work space depends mainly on the size of the object program, these general guidelines can be given. For a COBOL program of about 400 source statements, 10 tracks should be assigned to SYSLNK, SYS001, SYS002, and SYS003. For a COBOL program of about 800 source statements, 20 tracks should be assigned to SYSLNK, SYS001, SYS002, and SYS003.

FORTRAN WORKFILES (IBM 2311)

For a FORTRAN program, 6 tracks should be assigned to SYSLNK and 4 tracks to SYS001 and SYS002 for every 100 source statements.

For a Basic FORTRAN program, 4 tracks should be assigned to SYSLNK and to SYS001 for every 100 source statements.

PL/I WORKFILES (IBM 2311)

For each 100 PL/I source statements, 3 tracks should be reserved for SYSLNK; 5 tracks for SYS001; and 7 tracks each for SYS002 and SYS003.

This estimate is based on the following assumptions:

1. There are about 30 variable names per 100 statements in the external procedure.
2. The number of PL/I syntactical elements per source statement (except DECLARE statements and format lists) is about 10. For example, the statement
A=B+C;
has 6 syntactical elements, and the statement
READ FILE (F) INTO (AREA7);
has 10.

RPG WORKFILES (IBM 2311)

For an RPG program of about 150 source statements, 8 tracks should be assigned to SYSLNK and to SYS003, and 3 tracks to SYS001 and to SYS002.

For an RPG program of about 500 source statements, 22 tracks should be assigned to SYSLNK; 10 tracks to SYS001 and to SYS002; and 26 to SYS003.

For an RPG program of about 1,000 source statements, 44 tracks should be assigned to SYSLNK; 20 tracks to SYS001 and to SYS002; and 52 to SYS003.

IBM 2314 Workfile Requirements

This section contains information for determining the workfile requirements for COBOL, FORTRAN, Basic FORTRAN and RPG when the workfile is on an IBM 2314.

COBOL WORKFILES (IBM 2314)

Although the amount of COBOL work space depends mainly on the size of the object program, these general guidelines can be given. For a COBOL program of about 400 source statements, 5 tracks should be assigned to SYSLNK, SYS001, SYS002, and SYS003. For a COBOL program of about 800 source statements, 10 tracks should be assigned to SYSLNK, SYS001, SYS002, and SYS003.

FORTRAN WORKFILES (IBM 2314)

For a FORTRAN program, 3 tracks should be assigned to SYSLNK and 2 tracks each to SYS001 and SYS002 for every 100 source statements.

For a Basic FORTRAN program, 2 tracks should be assigned to SYSLNK and to SYS001 for every 100 source statements.

PL/I WORKFILES (IBM 2314)

For each 200 PL/I statements, 3 tracks should be reserved for SYSLNK; 5 tracks for SYS001; and 7 tracks each for SYS002 and SYS003. This estimate is based upon the following assumptions:

1. There are about 30 variable names per 100 statements in the external procedure.
2. The number of PL/I syntactical elements per source statement (except DECLARE statements and format lists) is about 10. For example, the statement
A=B+C
has 6 syntactical elements; the statement
READ FILE (F) INTO (AREA7)
has 10 syntactical elements.

RPG WORKFILES (IBM 2314)

For an RPG program of about 150 source statements, 5 tracks should be assigned to SYSLNK and to SYS003, and 2 tracks to SYS001 and to SYS002.

For an RPG program of about 500 source statements, 11 tracks should be assigned to SYSLNK, 5 tracks to SYS001 and to SYS002, and 13 to SYS003.

For an RPG program of about 1,000 source statements, 22 tracks should be assigned to SYSLNK, 10 tracks to SYS001 and to SYS002, and 26 to SYS003.

OPTIMUM ASSIGNMENT OF WORKFILES

Figure 77 lists the optimum assignments of the symbolic units used as workfiles when assembling and linkage editing or compiling and linkage editing user programs. While SYSRES and SYSLNK must be assigned to disk units, SYSnnn can be assigned to either tape or disk units. Where split cylinders are recommended, Figure 77 gives the division of the tracks in each cylinder between the symbolic units.

Key to figures:

- Workfile assignments are given by an integer and a letter n,m where:
 - n = the disk unit.
 - m = the disk cylinder(s) group assigned for the symbolic unit.
- Cylinder track numbers are given by integer(s) t where:
 - t = the number of disk tracks per cylinder to be assigned for the symbolic unit.
- Tape speeds are given by an integer s where:
 - s = the relative speed of the tape unit (the number 1 is the fastest speed).
- Tape channels are given by an integer c where:
 - c = the channel that the tape should be on.
- If two symbolic units have the same disk and cylinder(s) assignment indication (n,m), they share a split cylinder.
- Where applicable, the assignments that give the best overall performance are indicated.

Figure 77 (Part 1 of 3), shows that for a two disk system, disk workfile assignments for Assembler (14K variant) are:

Assign SYSRES	Disk drive number 1 Cylinder group A
Assign SYSLNK	Disk drive number 1 Cylinder group C
Assign SYS001	Disk drive number 2 Cylinder group A
Assign SYS002	Disk drive number 2 Cylinder group A

Assign SYS003 Disk drive number 1
 Cylinder group B

Interpreting the information collectively reveals that SYSRES, SYSLNK and SYS003 are assigned separate cylinders on disk 1, and SYS001 and SYS002 share the same cylinder group (A) on disk 2. Thus, Cylinder group (A) is split such that SYS001 and SYS002 each occupy 5 tracks of every cylinder in the group. To define the extents for workfiles, refer to the IBM publication System Control and System Service Programs, listed on the front cover of this manual.

Workfile Assignments For Two Disk Drive Systems							
Symbolic Unit Requirement	Assembler ¹ (14K Variant)	FORTTRAN	Basic FORTTRAN	COBOL	PL/I ³	RPG ²	
SYSRES	Disk Drive Number (n)	1	1	1	--	1	1
	Cylinder Group (m)	A	A	B	--	A	A
	Tracks Per Cylinder (t)	0-9	0-9	0-9	--	0-9	0-9
SYSLNK	Disk Drive Number (n)	1	2	2	2	2	2
	Cylinder Group (m)	C	A	A	B	B	A
	Tracks Per Cylinder (t)	0-9	0-3	0-4	0-9	0-9	0-6
SYS001	Disk Drive Number (n)	2	2	2	2	2	2
	Cylinder Group (m)	A	A	A	A	A	A
	Tracks Per Cylinder (t)	0-4	4-6	5-9	0-3	0-3	7,8,9
SYS002	Disk Drive Number (n)	2	2	Not Req'd	2	2	2
	Cylinder Group (m)	A	A	--	A	A	B
	Tracks Per Cylinder (t)	5-9	7-9	--	4,5,6	4,5,6	0-9
SYS003	Disk Drive Number (n)	1	Not Req'd	Not Req'd	2	2	2
	Cylinder Group (m)	B	--	--	A	A	C
	Tracks Per Cylinder (t)	0-9	--	--	7,8,9	7,8,9	0-9

Figure 77. Optimum Workfile Assignments for Assembling and Linkage Editing or Compiling and Linkage Editing (Part 1 of 3)

Workfile Assignments for One Disk Drive							
Symbolic Unit Requirement	Assembler (14K Variant)	FORTTRAN	Basic FORTTRAN	COBOL	PL/I	RPG	
SYSRES	Disk Drive Number (n)	1	1	1	--	1	1
	Cylinder Group (m)	A	A	A	--	A	A
	Tracks Per Cylinder (t)	0-9	0-9	0-9	--	0-9	0-9
SYSLNK	Disk Drive Number (n)	1	1	1	1	1	1
	Cylinder Group (m)	D	B	B	B	B	B
	Tracks Per Cylinder (t)	0-9	0-9	0-4	0-9	0-9	0-6
SYS001	Disk Drive Number (n)	1	1	1	1	1	1
	Cylinder Group (m)	B	A	B	A	C	B
	Tracks Per Cylinder (t)	0-4	0-3	5-9	0-3	0-3	7,8,9
SYS002	Disk Drive Number (n)	1	1	Not Req'd	1	1	1
	Cylinder Group (m)	B	A	--	A	C	C
	Tracks Per Cylinder (t)	5-9	4-9	--	4,5,6	4,5,6	0-9
SYS003	Disk Drive Number (n)	1	Not Req'd	Not Req'd	1	1	1
	Cylinder Group (m)	C	--	--	A	C	D
	Tracks Per Cylinder (t)	0-9	--	--	7,8,9	7,8,9	0-9

Figure 77. Optimum Workfile Assignments for Assembling and Linkage Editing or Compiling and Linkage Editing (Part 2 of 3)

Workfile Assignments for One Disk Drive with Three Tape Units							
Symbolic Unit Requirement ⁵	Assembler ¹ (14K Variant)	FORTTRAN	Basic ² FORTRAN	COBOL	PL/I	RPG	
SYS001	Tape ⁴ Speed (s)	3	1	Any	2	2	1
	Channel Requirement (c)	2	1	Any	2	2	2
SYS002	Tape ⁴ Speed (s)	2	2	Not Req'd	1	1	2
	Channel Requirement (c)	1	1	--	1	1	1
SYS003	Tape ⁴ Speed (s)	1	Not Req'd	Not Req'd	1	1	2
	Channel Requirement (c)	2	--	--	2	2	2

Note 1: The configuration that yields the best overall performance depends upon the variant of the assembler used (10K or 14K) and the storage available. The assignments shown assume that the 14K variant of the Assembler is used in a 64K environment. For cases with over approximately 500 lines of output, the two disk drive configuration yields the best overall performance. For cases with under approximately 500 lines of output, the three tape drive configuration yields the best overall performance.

Note 2: Indicates best overall performance.

Note 3: Two disk drive chart- For PL/I only users, compilation times will be faster if the following assignments are made for SYS001, SYS002 and SYS003 in place of those given.

Assign SYS001 to drive 2, group A, tracks 0-4
Assign SYS003 to drive 2, group A, tracks 5-9
Assign SYS002 to drive 1, group C, tracks 0-9

The assignments for SYSRES and SYSLNK are the same.

Note 4: Relative tape speeds are indicated by 1, 2 or 3. 1 designates the fastest tape unit, 2 the next fastest, etc.

Note 5: SYSRES and SYSLNK must always be assigned to disk in a one disk drive, three tape drive configuration.

Figure 77. Optimum Workfile Assignments for Assembling and Linkage Editing or Compiling and Linkage Editing (Part 3 of 3)

Index

- AB 38
- ADD 222
- Adding Unique Entries Using Merge Function 97
- ALLOC 39
- Allocate 39
- Allocating Library Sizes 10
- Allocating Library Sizes for 2311 and 2314 Disk Systems 14
- ALT 224
- Alternate Track Assignment-Data Cell Phases and Modules 249
- Alternate Track Assignment-Disk Phases and Modules 249
- AP 34
- APPENDIX A. IPL Control and ASSGN Statements for System Generation 222
- APPENDIX B. IOCS Modules for COBOL, RPG and PL/I 225
- APPENDIX C. IBM System Components Identification 233
- APPENDIX D. Disk Sort/Merge Modules 277
- APPENDIX E. Tape and Disk Sort/Merge Modules 282
- APPENDIX F. BPS Device Type Specifications (DD) 295
- APPENDIX G. Storage Requirements 296
- Assembler 17
- Assembler Diagnostics 20
- Assembler F 17
- Assembler F Macro Instruction Times: Work File Requirements 369
- Assembler F macro Instruction Times: Work Files Disk 369
- Assembler F Macro Instruction Work File Requirements 369
- Assembler F Phases and Modules 242
- Assembler F Work File Requirements for 2311 & 2314 369
- Assembler Phases and Modules 241
- Assembler Variants 17
- Assembler Work File Requirements for 2311 & 2314 368
- Assembler:
 - Macro Instruction Work File Requirements for 2311&2314 368
 - Macro Instruction Work File Requirements 368
 - Workfiles 366
- ASSGN Macro 43
- ASSGN Statement 43
- ASSGN, Parameters for 43
- AS1 Sample Problem 138
- AS2 Sample Problem 146
- AS3 Sample Problem 154
- AS4 Sample Problem 160
- AS5 Sample Problem 170
- AS6 Sample Problem 179
- At Least Two 2311 Disk Drives 14
- Autotest Phases and Modules 243
- Autotest Sample Problem 190
- Autotest Workfiles 25
- Autotest:
 - Work Area (IBM 2311) 371
- Background Partition Storage Requirements for DOS 12
- Basic FORTRAN Phases and Modules 244
- Basic FORTRAN Sample Problem 116
- Basic FORTRAN Subroutines 254,346
- Basic FORTRAN:
 - SUBROUTINES, Storage Requirement 3
- Basic QTAM Logic Modules 326
- BGPGR 40
- BMPX 39
- Boundary Alignment, Effect on Core Requirements 306
- BPS Utility Program 27
- BTAM Phases and Modules 257
- BTAM Translation Tables 356
- BTAM:
 - Data Event Control Block 326
 - Information 321-326,338-341,354-356
 - Macros - Source Statement Library 361
 - Main Storage Requirements 325
- BTMOD (BTAM Logic Module), Size of 325
- Buffered Work Files 17
- Bypass Initialize Disk 30
- Card-to-Disk Phases and Modules 249
- Card-to-Printer/Punch Phases and Modules 249
- Card-to-Tape Phases and Modules 250
- CBF 37
- CCHAIN 37
- CDMOD 225,310
- CDMOD (Card module), Size of 310
- CE 37
- CHANQ 41
- CHANSW 39,41
- CHARSET 36
- CHUN 41
- Clear Data Cell Phases and Modules 250
- Clear Disk Phases and Modules 250
- CLOCK 223
- COBOL and PL/I DASD Macros - Source Statement Library 364
- COBOL Debug Phases and Modules 244
- COBOL Phases and Modules 243
- COBOL Sample Problem 123
- COBOL Subroutines 253,346
- COBOL:
 - IOCS Modules 349
 - Subroutine, Storage Requirements 342-344
 - Workfile Requirements (IBM 2311) 3
 - Workfiles (IBM 2314) 372
- Computing the Size of a Supervisor 303
- CONFG Macro 34
- CONFG Parameters 34
- Considerations for Use of MERGE Function 102
- Console Buffering 37
- Control Information Storage Requirements (QTAM) 329
- Conventions for Merge Examples 98

Copy and Restore	27	Disk-to-Printer Phases and Modules	251
Copy Disk-to-Card Phases and Modules	250	Disk-to-Tape Phases and Modules	251
Copy Disk-to-Disk Phases and Modules	250	Distributed Volumes	7
Copy Disk/Data Cell-to-Tape Phases and Modules	250	Distribution Program	28
Copy System Tape	29	DSERV	22
Copy System Tape to Disk	29	DSERV Phases and Modules	239
Copying Selectively to Merge Libraries	97	DTFBT (Define the file BTAM), Size of Table	321
Core Image Library	8	DTFBTND (Define the file end BTAM), Size of Table	323
Core Image Library-IBM Supplied	7	DTFCD (Define the file card), Size of Table	309
Core Image Library, Components of	358	DTFCN (Define the file console), Size of Table	311
Core Image Phases	233	DTFDA (Define the file direct access device)	311
Core Image Transients	233	DTFDI (Define the file device independent) System Units	315
CORGZ	22	DTFIS (Define the file indexed sequential)	312
CORGZ Phases and Modules	240	DTFMR (Define the file - magnetic character reader)	315
Creating a Third Library from Existing Libraries	97	DTFMT (Define the file magnetic tape), Size of Table	316
CSERV	22	DTFOR (Define the file optical reader), Size of Table	317
CSERV Phases and Modules	239	DTFPH (Define the file physical IOCS), Size of Table	318
		DTFPR (Define the file printer), Size of Table	318
		DTFPT (Define the file paper tape reader)	319
DAMOD	230,312	DTFQT (Define the file QTAM), Size of Tables	327
DAMOD (Direct access device module), Size of	312	DTFQT DASD Audio Output Queue Table Requirements (QTAM)	329
DASDFP	38	DTFQT DASD Checkpoint Records Table Requirements	328
Data Cell to Printer Sample Problem	157	DTFQT DASD Communication Line Group File Table Requirements	328
Data Cell-to-Data Cell Phases and Modules	250	DTFQT DASD IBM 7772 Voc. File Table Requirements	328
Data Cell-to-Disk Phases and Modules	250	DTFQT DASD Main Storage Destination Queue, Table Requirements	328
Data Cell-to-Printer Phases and Modules	250	DTFQT DASD Main Storage Process Queue Table Requirement	328
Data Cell-to-Tape Phases and Modules	251	DTFQT DASD Message Queues File Table Requirements, QTAM	327
DATE	36	DTFSD (Define the file sequential DASD), Size of Table	320
DEC	35	DTFSR (Define the file serial device), Size of Table	321
DECK	35	DUMP	36
DELETECL	23	DVCGEN	41
DELETERL	23	DVCGEN Macro	41
DELETESL	23	DVCGEN Parameters	41
Deleting Entries and Merging Libraries	97	DVCGEN, Rules for Using	42
Device I/O Modules Requirements (QTAM)	331	DVCTYP	41
DFTRMLST (BTAM Table Requirements):		DWF	17
AUTOLST/AUTOWLST	324		
DIALST	323	Emulator	34
IDLST	324	Emulator (1401/1460 and 1440) Sample Problems	221
OPENLST	323		
SSLAST/SSAWLST	324		
WRAPLST	323		
WTTALST	324		
DFTRMLST (Define the terminal list BTAM)	323		
Diagnostics	20		
DIMOD	232		
DIMOD (Device independent system units modules)	315		
Directory Entries	358		
Disk Sort/Merge	149		
Disk to Printer Sample Problem	151		
Disk Work Files	17		
Disk Workfile Module Sizes	353		
Disk-to-Card Phases and Modules	251		
Disk-to-Data Cell Phases and Modules	251		
Disk-to-Disk Phases and Modules	251		
Disk-To-Printer (2311) Sample Problem	175		
Disk-To-Printer (2314) Sample Problem	183		

End of Supervisor Macro Instructions	43	IOCS: (Cont.)	
ERRS	35	Imperative Macros - Source Statement Library	364
EU	34	Modules for Compilers	349
Example of a Supervisor	304	Modules, Size of BTAM (BSC)	355
Example of MERGE Job Stream	102	Modules, Size of BTAM (Start-Stop)	354
Example One:		Modules, Size of BTAM (Translate Tables)	356
Results of System Generation	55	Modules, Size of COBOL	349
Example Three:		Modules, Size of Disk Work Files	353
Results of System Generation	89	Modules, Size of Nondevice Dependent	354
Example Two:		Modules, Size of PL/I	351,351
Results of System Generation	74	Modules, Size of RPG	352
Examples of MERGE	99-101	Modules, Size of Tape Work File	353
Examples of Sample Problem Execution and Output	116	Other Macro Instruction Storage Requirements	338-341
EXIT	40	IODEV	40
External Storage Requirements	356	IOTAB	39
		IOTAB Macro	40
File Definition Macros - Source Statement Library	361	IOTAB Parameters	40
File Names and Logical Unit Identification for Merge	102	IPL	223
FOPT Macro	36	IPL Phases and Modules	238
FOPT Parameters	36	ISMOD	228,313
Foreground Save Areas	306	ISMOD (Indexed sequential module), Size of	313
FORTTRAN Compatibility	19	IT	36
FORTTRAN Phases and Modules	244	JIB	40
FORTTRAN Sample Problem	118	Job Control and Linkage Editor Routines	237
FORTTRAN Subroutines	255,345	Job Control Phases and Modules	238
FORTTRAN:			
Subroutines, Storage Requirement	345		
Workfiles (IBM 2311)	371		
Workfiles (IBM 2314)	372		
FP	36		
FLPGR	40		
F2PGR	40		
General Library Updating Techniques	97	Library Block Lengths	358
General System Generation Procedure	23	Library Sizes	9
		LINES	36
IBM Supplied Core Image Library	7	Linkage Editor Phases and Modules	238
IBM Supplied Relocatable Library	7	Linkage Editor:	
IBM System/360 DOS Distribution	7	Workfiles	366
IBM 2314 Direct Access Storage Facility	87	LINKEDIT	23
IBM-Supplied Source Statement Library	7	LIST	35
IBM-Supplied System	52	Listings	17
Initialize Data Cell Phases and Modules	251	LISTX	35
Initialize Disk	29	LOG	36
Initialize Disk Phases and Modules	251		
Input/Output Device Configuration for Example One	55	Machine Requirements	10
Input/Output Device Configuration for Example Three	88	Macro Instruction Work File Requirements:	
Input/Output Device Configuration for Example Two	74	Assembler	368
Internal Storage Requirements	9,296	Assembler F	369
IOCS:		Macro Instructions For Generating a Supervisor	33
Declarative Macros Main Storage Requirements	306	Macro Rules	33
		Macro Sequence	33
		Magnetic Character Reader Sample Problems	203
		Magnetic Tape Module	317
		Main Storage Requirements For Subroutines	
		Basic FORTRAN	346

Main Storage Requirements for Subroutines
 FORTRAN 345
 Main Storage Requirements for Elements of
 Supervisor 16,297
 Main Storage Requirements for Subroutines:
 COBOL 342-344
 PL/I 347
 MAINT 22
 MAINT Phases and Modules 239
 Maintenance Macro - Source Statement
 Library 364
 Maintenance Procedures 97
 MAPS 17
 Maximum Unprotected Supervisor Storage 46
 MICR 34
 MODE 42
 Model 35
 MPS 34
 MPS Utility Macro Storage Requirements
 306-309
 MRMOD (Magnetic Character Reader module)
 315
 MTMOD 227,317
 MTMOD (Magnetic tape module), Size of 31
 Multiprogramming Sample Problem 195
 Multitasking 34

Nondevice Dependent IOCS Modules, Size of
 354

OC 36
 OLTEP Phases and Modules 268
 One IBM 2311 Disk Drive 71
 One 2311 Disk Drive 13
 OPEN 233
 Operational Pack, Planning a 12
 Operational Pack 12
 Optical Reader Sample Problems 211
 Optimum Assignment of Work Files:
 Assembly and Link 373-377
 Compile and Link 373-377
 Options Affecting Generation of a
 Supervisor 16,297-302
 Organization of the System Pack 356
 ORMOD (Optical reader module), Size of
 318

Parameters for ASSGN 43
 Parameters for CONFG 34
 Parameters for DTFBT Table Requirements
 Formula 322
 Parameters for DVCGEN 41
 Parameters for FOPT 36
 Parameters for IOTAB 40
 Parameters for PIOCS 39
 Parameters for STDJC 35
 Parameters for SUPVR 34
 PC 36
 Phase Name 233
 Physical and Logical I/O Assignments,
 Sample Problems 109

Physical Transient Overlays 37
 PIOCS 39
 PIOCS Macro 39
 PIOCS Parameters 39
 PL/I 18
 PL/I and Systems Input/Output on Disk 18
 PL/I Phases and Modules 245
 PL/I Sample Problem 133
 PL/I Subroutines 256,347
 PL/I Variants 18
 PL/I:
 IOCS Modules 351
 Subroutines, Storage Requirements
 347
 Workfiles (IBM 2311) 371
 Workfiles (IBM 2314) 372
 Planning a Supervisor 10
 Planning System Generation 7
 Planning the Libraries 8
 Preassembled IOCS Modules 225
 Private Libraries 9
 PRMOD 226,319
 PRMOD (Printer module) 319
 PTMOD (Paper tape reader module), Size of
 319
 PTO 37

QTAM Phases and Modules 262
 QTAM Storage Requirements, Control
 Information 329
 QTAM Storage Requirements:
 Device I/O Modules 331
 QTAM:
 Basic Logic Modules 327
 Device I/O Modules - Storage
 Requirements 331
 Macro Instructions Storage
 Requirements 332-337
 Macros - Source Statement Library
 362
 Requirement for Buffers - Nonaudio
 Applications 330
 Requirements for Buffers - Audio
 Application 330
 Storage Requirements 326

Relocatable Library 9
 Relocatable Library IBM-Supplied 7
 Relocatable Library, Components of 360
 Relocatable Module Identification 238
 Relocatable Subroutines, Size of:
 Basic FORTRAN 346,346
 COBOL 342,342-344
 FORTRAN 345
 PL/I 347
 Replacing Identical Entries Using Merge
 Function 97
 Restart Phases and Modules 239
 Restore Card or Tape to Disk 27
 Restore Card to Disk Phases and Modules
 251
 Restore System Tape to Disk 29,31
 Restore Tape-to-Disk/Data Cell Phases and
 Modules 251

Retrieving the Sample Problems 105
 RPG Phases and Modules 248
 RPG Sample Problem 129
 RPG:
 IOCS Modules 352
 Workfiles (IBM 2311) 371
 Workfiles (IBM 2314) 372
 RRSERV 22
 RRSERV Phases and Modules 238
 Rules for Using Macros 33
 RWTAU 39

 Sample Problem Data 105
 Sample Problem Identification and Sequence 105
 Sample Problem Preparation 105
 Sample Problem Work Files 109
 Sample Problems 105
 Sample Problems as Successive Job Steps 109
 Sample Problems, Library Blocks 364
 SDMOD 320
 SDMOD (Sequential DASD Module), Size of 320
 SDMODW 232
 SDMODXX 227
 SELCH 39
 SEND 43
 SEND Macro 43
 SEND, SP=NO 44
 SEND, SP=YES 45
 SENDN, SP=NO 45
 SENDN, SP=YES 45
 SET 223
 SETIME 39
 Size of Supervisors 10,297
 SKSEP 37
 Sort 277
 Source Statement Library 9
 Source Statement Library Macros: 269
 Source Statement Library, IBM-Supplied 7
 Source Statement Library:
 BTAM Macros 361
 COBOL DASD Modules 364
 Components of 361-364
 File Definition Macros 361
 IOCS Imperative Macros 362
 Maintenance Macros 364
 MPS Utility Macros 364
 PL/I DASD Macros 364
 QTAM Macros 362
 Sample Problems 365
 Supervisor Generation Macros 364
 Supervisor Communication Macro 361
 SP 35
 SSERV 22
 SSERV Phases and Modules 240
 Standard Label Option 26
 Standard System Dump Phases and Modules 238
 STDJC 35
 Storage Requirements 296
 STXIT 39
 Subroutines 253,342

Subroutines, Relocatable:
 Basic FORTRAN 346,346
 COBOL 342,342-344
 FORTRAN 345
 PL/I 347
 Supervisor 33,296
 Supervisor and IPL Programs 237
 Supervisor:
 Communication Macros - Source Statement Library 361
 Generation Macros - Source Statement Library 364
 Macro Instructions 304
 Macro Instructions Storage Requirements 305
 Main Storage Requirements 297-302
 Supervisors Shipped by IBM 12,296
 SUPVR Macro 34
 Switchable Channels 222
 SYM 35
 SYSFIL 38
 SYSnnn 223
 System Configuration 10
 System Generation and Maintenance Procedure 22
 System Generation Techniques 22

 Tape 39
 Tape and Disk Sort/Merge 2311 Application Sample Problem 173
 Tape and Disk Sort/Merge 2314 Application Sample Problem 182
 Tape and Disk Sort/Merge 2400 Application Sample Problem 163
 Tape Compare Phases and Modules 252
 Tape Sort/Merge Phases and Modules 249
 Tape Sort/Merge Sample Problem 141
 Tape To Printer (2400) Sample Problem 16
 Tape to Printer Phases and Modules 252
 Tape to Printer Sample Problem 143
 Tape Work Files 17
 Tape Workfile Modules 353
 Tape-to-Card Phases and Modules 252
 Tape-to-Data Cell Phases and Modules 252
 Tape-to-Disk Phases and Modules 252
 Tape-to-Tape Phases and Modules 252
 Tape, Disk, and Data Cell Configurations 110
 TEB 36
 Telecommunications 257
 TIMER 35
 TP 34
 Translating System Dump Phases and Modules 238
 TRKHL 38
 TSWTCH 39
 TWF 17
 Two IBM 2311 Disk Drives 52

 Unprotected Supervisor Storage 46
 User Decisions and Considerations 16
 Using the Merge Function of the CORGZ Librarian Program 97

Utilities	249
Utility Programs (BPS)	27
Values for Communication Line Group Table	328
Variants of IBM Supplied Assembler	17
Variants of PL/I	18
Vocabulary File Utility	253
Volume Serial Number	25
VTOC Display (BJS) Phases and Modules	252
VTOC Display (MPS) Phases and Modules	252
WAITM	38
Warning Diagnostics	20
Work File Assignments:	
For One Disk Drive System	376
For One Disk Drive, Three Tapes	377
For Two Disk Drive System	375
Workfile Module	29
Workfile Requirements for Linkage Editor and Assembler	366
Workfile Requirements:	
(IBM 2311)	370
(IBM 2314)	372
Assembler	367
Assembler F	367
COBOL (IBM 2311)	371
COBOL (IBM 2314)	372
FORTRAN (IBM 2311)	371
FORTRAN (IBM 2314)	372
Linkage Editor	366
PL/I (IBM 2311)	371
RPG (IBM 2311)	371,371
RPG (IBM 2314)	372
Workfiles	17
Workfile MTMOD	231
X'CUU'	223
X'SS'	224
XREF	35

Reader's Comments Form

IBM System/360
Disk Operating System
System Generation and Maintenance

C24-5033-7

Your comments, accompanied by answers to the following questions, help us produce better publications for your use. If your answer to a question is "No" or requires qualification, please explain in the space provided below. Please give specific page and line references with your comments when appropriate. All comments will be handled on a non-confidential basis. Copies of this and other IBM publications can be obtained through IBM branch offices.

- | | <i>Yes</i> | <i>No</i> |
|--|---|--------------------------|
| ● Does the publication meet your needs? | <input type="checkbox"/> | <input type="checkbox"/> |
| ● Did you find the material: | | |
| Easy to read and understand? | <input type="checkbox"/> | <input type="checkbox"/> |
| Organized for convenient use? | <input type="checkbox"/> | <input type="checkbox"/> |
| Complete? | <input type="checkbox"/> | <input type="checkbox"/> |
| Well illustrated? | <input type="checkbox"/> | <input type="checkbox"/> |
| Written for your technical level? | <input type="checkbox"/> | <input type="checkbox"/> |
| ● What is your occupation? _____ | | |
| ● How do you use this publication: | | |
| As an introduction to the subject? <input type="checkbox"/> | As an instructor in a class? <input type="checkbox"/> | |
| For advanced knowledge of the subject? <input type="checkbox"/> | As a student in a class? <input type="checkbox"/> | |
| For information about operating procedures? <input type="checkbox"/> | As a reference manual? <input type="checkbox"/> | |

Your comments:

Thank you for your cooperation. No postage necessary if mailed in the U.S.A.

Your comments, please . . .

This publication is one of a series that serves as a reference source for systems analysts, programmers, and operators of IBM systems. Your answers to the questions on the back of this form, together with your comments, help us produce better publications for your use. Each reply is carefully reviewed by the persons responsible for writing and publishing this material. All comments and suggestions become the property of IBM.

Please note: Requests for copies of publications and for assistance in using your IBM system should be directed to your IBM representative or to the IBM sales office serving your locality.

Fold

Fold

FIRST CLASS
PERMIT NO. 170
ENDICOTT, N. Y.

BUSINESS REPLY MAIL
NO POSTAGE STAMP NECESSARY IF MAILED IN THE UNITED STATES

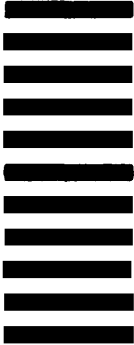

POSTAGE WILL BE PAID BY . . .

IBM Corporation
P. O. Box 6
Endicott, N. Y. 13760

Attention: Programming Publications, Dept. 157

Fold

Fold



International Business Machines Corporation
Data Processing Division
112 East Post Road, White Plains, N.Y. 10601
[USA Only]

IBM World Trade Corporation
821 United Nations Plaza, New York, New York 10017
[International]

IBM

**International Business Machines Corporation
Data Processing Division
112 East Post Road, White Plains, N.Y. 10601
(USA Only)**

**IBM World Trade Corporation
821 United Nations Plaza, New York, New York 10017
(International)**