

# EPG Software Configuration Overview

## OPERATION DIRECTIONS

## **Copyright**

© Ericsson AB 2012–2018. All rights reserved. No part of this document may be reproduced in any form without the written permission of the copyright owner.

## **Disclaimer**

The contents of this document are subject to revision without notice due to continued progress in methodology, design and manufacturing. Ericsson shall have no liability for any error or damage of any kind resulting from the use of this document.

## **Trademark List**

All trademarks mentioned herein are the property of their respective owners. These are shown in the document Trademark Information.



# Contents

<b>1</b>	<b>Introduction</b>	<b>1</b>
1.1	Scope	1
1.2	Target Groups	1
<b>2</b>	<b>Default Root Password</b>	<b>1</b>
<b>3</b>	<b>Configuration Guidelines</b>	<b>2</b>
3.1	Using the CLI	2
3.1.1	Command Modes and Prompts	2
3.2	Stop and Start the EPG	3
3.2.1	Terminate User Sessions	3
3.2.2	Stop and Start the Standalone SGW on Node Level	3
3.2.3	Stop and Start the Standalone GGSN or PGW on Node Level	6
3.2.4	Stop and Start the Combined SGW and PGW on Node Level	8
<b>4</b>	<b>Basic Configuration</b>	<b>11</b>
4.1	Configure Node Identifiers	11
4.1.1	Configure an EPG Node Identifier	12
4.1.2	Configure an SGW Identifier	12
4.1.3	Configure a GGSN/PGW Identifier	13
4.2	Configure Physical Interfaces	13
4.3	Configure Logical Interfaces with IP Addresses and Routing Instances	13
4.4	Configure Offline Charging	13
4.5	Configure APNs	14
4.6	Migrate the EPG for Deployment in EPS	14
4.7	Configure System Syslog for ISP Logging	14
<b>5</b>	<b>Optional Configuration</b>	<b>14</b>
5.1	Connectivity and Routing	14
5.1.1	PDP Context and EPS Bearer Properties	14
5.1.2	GTP Properties	14
5.1.3	PMIPv6 Properties	15
5.1.4	L2TP	15
5.1.5	DHCP	15
5.1.6	RADIUS	15
5.2	Event-Based Monitoring	15
5.3	Quality of Service	15
5.4	Resilience	15



5.5	SACC	15
5.5.1	Content Filtering	16
5.5.2	PISC	16
5.5.3	Charging Methods	16
5.5.4	Credit Control	16
5.5.5	Policy and Charging Control	16
5.5.6	Aware Policy-Based Routing	16
5.6	PGW Pause Charging	16
5.7	Operation and Maintenance	16
5.8	Traffic Redirection	17
5.9	Shared IP Pool	17
5.10	IMS Emergency Session	17
5.11	Inter-Chassis Redundancy	17
5.12	Service Chaining	17
<b>6</b>	<b>EPG Configuration Examples</b>	<b>17</b>
6.1	Determine the Network Environment	18
6.2	Determine the IP Addresses	20
6.3	Configure Physical Interfaces	24
6.4	Configure EPG Logical Interfaces	25
6.5	Configure Other EPG Services	26
	<b>Reference List</b>	<b>33</b>



# 1 Introduction

This document gives an overview of the basic and optional software configuration tasks on the Evolved Packet Gateway (EPG) as well as configuration guidelines, and includes references to configuration instructions.

## 1.1 Scope

This document covers the following issues:

- Information on the default root password
- An overview of configuration guidelines
- An overview of basic EPG software configuration tasks
- An overview of optional EPG software configuration tasks
- Examples of an EPG software configuration

**Note:** Do not issue a commit command when the EPG application is stopped unless specifically instructed. The validation of the configuration cannot be performed on a stopped node. For information on how to stop and start the EPG application, see Section 3 on page 1.

**Note:** In this document, the term physical interface refers to the interface configured in Network Functions Virtualization Infrastructure (NFVI).

## 1.2 Target Groups

This document is intended for personnel performing configuration of the EPG.

# 2 Default Root Password

At initial installation of the EPG, use the default root password **root** to access the node.

The root password is reset to the default value after an upgrade or update. Therefore, change the default root password immediately after an initial installation, software upgrade, or update. For more information, refer to [Security Management](#).



## 3 Configuration Guidelines

This section lists some necessary guidelines for consideration when performing EPG configuration.

### 3.1 Using the CLI

The primary user interface to the EPG is the CLI. For more information about using CLI commands, refer to [Using the CLI](#) and for information about specific commands, refer to [Action Commands for the vRE](#) and [Show Commands for the vRE](#).

#### 3.1.1 Command Modes and Prompts

Table 1 shows the CLI modes of the Ericsson Core CLI (ECCLI).

Table 1

Mode	Access	Prompt	Example
Ericsson operational	Operational mode is the default mode.	[local]Ericsson#	[local]Ericsson#
Ericsson configuration	Enter the Ericsson configuration mode by using the following command from the Ericsson operational mode:  [local]Ericsson# <b>config</b>	Ericsson(config)#	[local]Ericsson# <b>config</b> Ericsson(config)# <b>epg</b> <b>pgw apn apn1.com</b>
Shell <sup>(1)</sup>	Enter the shell mode by using the following command from the Ericsson operational mode:  [local]Ericsson# <b>start shell</b>	bash-4.2\$	[local]Ericsson# <b>start shell</b> bash-4.2\$

(1) The shell mode is only to be used according to Ericsson directions and in strict accordance to the procedures described in the CPI.

For information on administrative privilege levels and user roles required to access the different CLI modes, refer to [Security Management](#).



The ECCLI supports the following:

- Autocomplete, using the **Tab** key
- Help text and support, using the **?** key

## 3.2 Stop and Start the EPG

Some configuration changes require that the GGSN, PGW, or SGW applications be stopped before making such changes. The GGSN, PGW, or SGW applications can also be stopped before or after the initial start of a new software application.

Mandatory GGSN-, PGW-, or SGW-specific configuration needs to be made before start of the specific application is possible. This configuration is performed during an upgrade or update of installations already running a specific application or during an initial software installation. The procedure for upgrade and update is described in [Software Upgrade for Virtual EPG](#). The procedure for initial software installation, is described in [Deploying Virtual EPG](#).

**Note:** Activation of PGW-specific functionality by configuration is not a prerequisite for start of the GGSN application. The procedure for activation of the PGW and SGW functionality is described in [EPG Migration for Deployment in EPS](#).

The EPG can be stopped on node level for all deployment types.

### 3.2.1 Terminate User Sessions

User sessions can be terminated using two commands, `terminate-idle-session-start` and `terminate`.

The termination of idle user sessions is an optional feature controlled by the action command `terminate-idle-session-start`. The command is used to terminate idle user sessions on the SGW, PGW, or GGSN nodes. It is used to empty a node partially or fully without impacting active user sessions.

To terminate both active and idle user sessions use the `terminate` command. The termination of user sessions is limited by the configured throttling rates. Using the `terminate` command results in active user sessions being interrupted.

See [Session Management](#) for more information on `terminate-idle-session-start` and throttling rates.

### 3.2.2 Stop and Start the Standalone SGW on Node Level

The following sections describe the stop and start procedures for the standalone SGW on node level.



### 3.2.2.1 Stop the Standalone SGW

The standalone SGW can be stopped on node level according to the following procedure.

---

---

#### Warning!

The following procedure is service-affecting and causes EPG downtime. Depending on the traffic load, this procedure can take a long time to execute, possibly several hours.

---

---

1. Block the creation of new user sessions on the SGW:

```
Ericsson(config)# epg sgw control-plane session block node
Ericsson(config)# commit
```

2. Terminate idle user sessions on the SGW, or user sessions that become idle while the command is running:

```
[local]Ericsson#epg sgw control-plane session terminate-idle-
session-start
```

3. Verify the number of users sessions that are remaining on the SGW to determine when is appropriate to run the terminate command:

```
[local]Ericsson#epg sgw statistics
```

The `sgw-nbr-ues` field shows the total number of UE devices on the SGW.

The following command displays the number of user sessions remaining on the SGW with a QCI value of 1:

```
[local]Ericsson#epg sgw statistics-qci qci 1 detail-level brief
interface all
```

The following command displays the number of bearers per ARP priority level:

```
[local]Ericsson#epg sgw statistics-arp
```

4. Terminate all remaining user sessions on the SGW:

```
[local]Ericsson#epg sgw control-plane session terminate
```

**Note:** The `terminate` command is only required if there are user sessions remaining on the SGW.

5. Verify that the termination has been finalized. All user sessions must be terminated before the application can be stopped:



```
[local]Ericsson#epg sgw statistics
```

6. Verify that SGW Charging Data Records (CDRs) or Rf Accounting-Requests (ACRs) are not being generated any more:

```
[local]Ericsson#epg sgw statistics-charging
```

Ensure that the `rf-acct-req-pending-to-be-written-to-disk` and `bp-cdrs-pending-to-be-written-to-disk` fields are equal to zero.

7. Stop the node function by setting a stop configuration:

```
Ericsson(config)# epg sgw stop node
Ericsson(config)# commit
```

If the EPG application is stopped, the Redundant File Manager (RFM) process rebuilds the file system after 5 minutes. Stop the RFM process to prevent it from removing a custom file directory structure.

8. Stop the RFM process, using the following command:

```
[local]Ericsson#process stop rfm
```

9. Verify that the RFM process is stopped:

```
[local]Ericsson#show process rfme
```

Ensure that the STATE of the RFM process is stop.

### 3.2.2.2

#### Start the Standalone SGW

The standalone SGW can be started on node level by using the following procedure.

1. Start the node by deleting the stop setting on node level:

```
Ericsson(config)# no epg sgw stop
Ericsson(config)# commit
```

2. Unblock the user sessions by deleting the block setting on node level:

```
Ericsson(config)# no epg sgw control-plane session block node
Ericsson(config)# commit
```

**Note:** After an upgrade or node reload, the RFM process starts automatically. If no upgrade or node reload has been performed, the RFM process needs to be started manually. To start the RFM process, use the following command:

```
[local]Ericsson#process start rfm
```

3. Verify that the RFM process is running:

```
[local]Ericsson#show process rfm
```



### 3.2.3 Stop and Start the Standalone GGSN or PGW on Node Level

The following sections describe the stop and start procedures for the standalone GGSN or PGW on node level.

#### 3.2.3.1 Stop the Standalone GGSN or PGW

The standalone GGSN or PGW can be stopped on node level according to the following procedure.

---

---

### Warning!

The following procedure is service-affecting and causes EPG downtime. Depending on the traffic load, this procedure can take a long time to execute, possibly several hours.

---

---

1. Block the creation of new user sessions on the GGSN or PGW:

```
Ericsson(config)# epg pgw control-plane session block node
Ericsson(config)# commit
```

Blocking the GGSN or PGW causes all incoming bearer creation requests to be rejected.

2. To terminate idle user sessions on the GGSN or PGW or user sessions that become idle while the command is running:

```
[local]Ericsson#epg pgw control-plane session terminate-idle-session-start idle-monitor-timer <timer-value>
```

The value of `idle-monitor-timer` indicates the maximum time in seconds for which a session is allowed to be kept with no uplink payload. The range of `idle-monitor-timer` is 1–65535 seconds.

If the user session is idle for 20 seconds and the `terminate-idle-session-start` command is configured with the `idle-monitor-timer` set as 30 seconds, the GGSN or PGW retains the session for 10 seconds with no payload and then deletes the user session.

**Note:** The user sessions that have dedicated bearers with QCI values that have been configured to prevent idle termination are kept.

To display QCI values for bearers, enter the following command:

```
[local]Ericsson#epg pgw statistics of qci
```

3. Verify the number of user sessions that are remaining on the PGW to determine when is appropriate to run the `terminate` command:



```
[local]Ericsson#epg pgw statistics of brief
```

The following field displays the number of active PDP contexts:

```
pdp-active
```

The following field displays the number of active IPv4 and IPv6 EPS bearers:

```
eps-active-bearer
```

4. Terminate all remaining user sessions on the GGSN or PGW:

```
[local]Ericsson#epg pgw control-plane session terminate
```

**Note:** The terminate command is only required if there are user sessions remaining on the GGSN or PGW.

5. Verify that the termination has been finalized. All user sessions must be terminated before the application can be stopped:

```
[local]Ericsson#epg pgw statistics of brief
```

6. Verify that GGSN/PGW CDRs or Rf ACRs are not being generated any more:

```
[local]Ericsson#epg pgw statistics of charging
```

Ensure that the ftp-cdrs-to-be-written-to-disk,gtp-cdrs-to-be-written-to-disk and rf-acct-req-to-be-written-to-disk fields are equal to zero.

7. Stop the node function by setting a stop configuration:

```
Ericsson(config)#epg pgw stop node
Ericsson(config)# commit
```

If the EPG application is stopped, the RFM process rebuilds the file system after 5 minutes. Stop the RFM process to prevent it from removing a custom file directory structure.

8. Stop the RFM process, using the following command:

```
[local]Ericsson#process stop rfm
```

9. Verify that the RFM process is stopped:

```
[local]Ericsson#show process rfm
```

Ensure that the STATE of the RFM process is stop.

### 3.2.3.2 Start the Standalone GGSN or PGW

The standalone GGSN or PGW can be started on node level by using the following procedure.

1. Start the node by deleting the stop setting on node level:



```
Ericsson(config)# no epg pgw stop  
Ericsson(config)# commit
```

2. Unblock the user sessions by deleting the block setting on node level:

```
Ericsson(config)# no epg pgw control-plane session block node  
Ericsson(config)# commit
```

**Note:** After an upgrade or node reload, the RFM process starts automatically. If no upgrade or node reload has been performed, the RFM process needs to be started manually. To start the RFM process, use the following command:

```
[local]Ericsson#process start rfm
```

3. Verify that the RFM process is running:

```
[local]Ericsson#show process rfm
```

### 3.2.4 Stop and Start the Combined SGW and PGW on Node Level

The following sections describe the stop and start procedures for the combined SGW and PGW on node level.

#### 3.2.4.1 Stop the Combined SGW and PGW

The combined SGW and PGW can be stopped on node level according to the following procedure.

---

---

### Warning!

The following procedure is service-affecting and causes EPG downtime. Depending on the traffic load, this procedure can take a long time to execute, possibly several hours.

---

---

1. Block the creation of new SGW and PGW user sessions:

```
Ericsson(config)# epg sgw control-plane session block node  
Ericsson(config)# epg pgw control-plane session block node  
Ericsson(config)# commit
```

2. Terminate idle user sessions on the SGW or user sessions that become idle while the command is running:

```
[local]Ericsson#epg sgw control-plane session terminate-idle-  
session-start
```



3. Verify the number of user sessions that are remaining on the SGW to determine when is appropriate to run the terminate command:

```
[local]Ericsson#epg sgw statistics
```

The `sgw-nbr-ues` field shows the total number of UE devices on the SGW.

The following command displays the number of user sessions remaining on the SGW with a QCI value of 1:

```
[local]Ericsson#epg sgw statistics-qci qci 1 interface all
detail-level brief
```

The following command displays the number of bearers per ARP priority level:

```
[local]Ericsson#epg sgw statistics-arp
```

4. Terminate all remaining user sessions on the SGW:

```
[local]Ericsson#epg sgw control-plane session terminate
```

**Note:** The `terminate` command is only required if there are user sessions remaining on the SGW or PGW.

5. Terminate idle user sessions on the PGW or user sessions that become idle while the command is running:

```
[local]Ericsson#epg pgw control-plane session terminate-idle-session-start
idle-monitor-timer <timer-value>
```

The value of `idle-monitor-timer` indicates the maximum time in seconds for which a session is allowed to be kept with no uplink payload. The range of `idle-monitor-timer` is 1–65535 seconds.

**Note:** The user sessions that have dedicated bearers with QCI values that have been configured to prevent idle termination are kept.

To display QCI values for bearers, enter the following command:

```
[local]Ericsson#epg pgw statistics of qci
```

6. Verify the number of user sessions that are remaining on the PGW to determine when is appropriate to run the terminate command:

```
[local]Ericsson#epg pgw statistics of brief
```

The following field displays the number of active PDP contexts:

```
pdp-active
```

The following field displays the number of active IPv4 and IPv6 EPS bearers:

```
eps-active-bearer
```



7. Terminate all remaining user sessions on the PGW:

```
[local]Ericsson#epg pgw control-plane session terminate
```

**Note:** The terminate command is only required if there are user sessions remaining on the SGW or PGW.

8. Verify that the termination has been finalized. All user sessions must be terminated before the applications can be stopped:

```
[local]Ericsson#epg sgw statistics  
[local]Ericsson#epg pgw statistics of brief
```

9. Verify that CDRs or Rf ACRs are no longer being generated.

If SGW charging is enabled, verify that CDRs or Rf ACRs are no longer being generated:

```
[local]Ericsson#epg sgw statistics-charging
```

If PGW charging is enabled, verify that CDRs or Rf ACRs are no longer being generated:

```
[local]Ericsson#epg pgw statistics of charging
```

Ensure that the following fields are equal to zero:

- ftp-cdrs-to-be-written-to-disk
- gtp-cdrs-to-be-written-to-disk
- rf-acct-req-to-be-written-to-disk
- rf-acct-req-pending-to-be-written-to-disk
- bp-cdrs-pending-to-be-written-to-disk

10. Stop the SGW and PGW node functions simultaneously by setting a stop configuration:

**Note:** Stopping either the SGW or PGW only is not supported.

```
Ericsson(config)# epg sgw stop node  
Ericsson(config)# epg pgw stop node  
Ericsson(config)# commit
```

If the EPG application is stopped, the RFM process rebuilds the file system after 5 minutes. Stop the RFM process to prevent it from removing a custom file directory structure.

11. Stop the RFM process, using the following command:

```
[local]Ericsson#process stop rfm
```



12. Verify that the RFM process is stopped:  

```
[local]Ericsson#show process rfm
```

 Ensure that the STATE of the RFM process is stop.

### 3.2.4.2 Start the Combined SGW and PGW

The combined SGW and PGW can be started on node level by using the following procedure.

**Note:** The SGW and PGW must be started together for the start to be effective. Start does not take place until after a commit is performed.

1. Start the SGW and PGW node functions simultaneously by deleting the stop settings on node level:

```
Ericsson(config)# no epg sgw stop
Ericsson(config)# no epg pgw stop
Ericsson(config)# commit
```

2. Unblock the SGW and PGW sessions, by deleting the block setting on node level:

```
Ericsson(config)# no epg pgw control-plane session block node
Ericsson(config)# no epg sgw control-plane session block node
Ericsson(config)# commit
```

**Note:** After an upgrade or node reload, the RFM process starts automatically. If no upgrade or node reload has been performed, the RFM process needs to be started manually. To start the RFM process, use the following command:

```
[local]Ericsson#process start rfm
```

3. Verify that the RFM process is running:

```
[local]Ericsson#show process rfm
```

## 4 Basic Configuration

This section lists the configuration tasks required to establish basic functionality.

### 4.1 Configure Node Identifiers

This section describes the configuration for any of the following node identifiers:



- An EPG identifier
- An SGW identifier
- A GGSN/PGW identifier

By default, the length of a node identifier cannot be longer than 20 characters. When `long-node-id-allowed` is configured, the maximum length for each of `epg-identifier`, `sgw-identifier`, and `pgw-identifier` is 32 characters. If only one character is used for the node identifier, this character must not be equal to 1.

To configure long node identifier, include the following statement:

```
Ericsson(config)# epg node
    long-node-id-allowed
```

#### 4.1.1 Configure an EPG Node Identifier

An EPG identifier is included in Fault Management (FM) alarms and alerts, and Event-Based Monitoring (EBM) stream header records. The EPG identifier is also included in the PM statistic data of all node levels (that is all xml files of the node) as localDn even if a PGW/SGW identifier is set.

To configure an EPG identifier, include the following statement:

```
Ericsson(config)# epg node
    node-name <epg-identifier>
```

If an EPG identifier is not configured, the default EPG identifier is the host name of the router.

#### 4.1.2 Configure an SGW Identifier

An SGW identifier is included in generated SGW charging data files and SGW-specific alarms and alerts.

To configure an SGW identifier, include the following statement:

```
Ericsson(config)# epg sgw
    node <sgw-identifier>
```

**Note:** To run the SGW application, it is mandatory to configure the SGW identifier.

The node identifier is included in the PM statistic data of all SGW levels (that is all xml files of the SGW) as localDn even if an SGW identifier is set.



### 4.1.3 Configure a GGSN/PGW Identifier

A GGSN/PGW identifier is included in generated GGSN/PGW CDRs and GGSN/PGW-specific alarms and alerts, and as NAS-Identifier in RADIUS messages.

To configure a GGSN/PGW identifier, include the following statement:

```
Ericsson(config)# epg pgw
    node <pgw-identifier>
```

The node identifier is included in the PM statistic data of all PGW levels (that is all xml files of the PGW) as localDn even if a PGW identifier is set.

## 4.2 Configure Physical Interfaces

For information on configuring the physical interfaces and Internet Protocol (IP) addresses, refer to [Contexts and Interfaces](#).

For information on service chaining interfaces in (S)Gi-LAN, refer to [Service Chaining Configuration](#).

## 4.3 Configure Logical Interfaces with IP Addresses and Routing Instances

Logical interfaces can be configured for the following interfaces:

- For the SGW: S4-C/S11, S5/S8-C, S5/S8-U, S1-U/S4-U/S12, Rf, and Gom
- For the GGSN/PGW: Gn/Gp, S5/S8, S2a, S2b, Gx+, Gy+, S6b, S6b Auth, Rf, and Gom

For information on configuring logical interfaces with IP addresses and routing instances, refer to [GTP Interface Configuration](#) and [EPG Board Configuration](#).

For information on configuring other relevant interfaces such as the EBM logical interface, see the corresponding interface configuration documents.

For information on selecting the master routing instance or virtual routing instances for the logical interfaces, refer to [Routing](#).

For information on service chaining interfaces in (S)Gi-LAN, refer to [Service Chaining Configuration](#).

## 4.4 Configure Offline Charging

For information on configuring CDR-based charging and Rf charging, refer to [Offline Charging Configuration](#).



## 4.5 Configure APNs

For information on configuring Access Point Names (APNs), refer to [APN Configuration](#).

## 4.6 Migrate the EPG for Deployment in EPS

For information on migrating the EPG for deployment in the Evolved Packet System (EPS) network, refer to [EPG Migration for Deployment in EPS](#)

## 4.7 Configure System Syslog for ISP Logging

Logging of ISP-related information is performed using system logging interface, configured to write specific events to the ISP log file. For more information about default system syslog configuration, refer to [EPG Logs](#).

**Note:** The time stamp format for the ISP log is configurable. This format with Universal Time Coordinated (UTC) offset is recommended due to its compatibility with the ISPTool. Refer to [Logging](#) for how to configure the time stamp format.

# 5 Optional Configuration

This section lists further configuration options available in the EPG.

## 5.1 Connectivity and Routing

This section lists configuration options related to EPG connectivity and routing.

### 5.1.1 PDP Context and EPS Bearer Properties

For information on configuring Packet Data Protocol (PDP) context and EPS bearer properties, refer to [APN Configuration](#).

### 5.1.2 GTP Properties

For information on configuring GPRS Tunneling Protocol (GTP) properties, refer to [GTP Properties Configuration](#).



### 5.1.3 PMIPv6 Properties

For information on configuring the PMIPv6 PDN connection properties, refer to [APN Configuration](#).

### 5.1.4 L2TP

For information on configuring Layer Two Tunneling Protocol (L2TP), refer to [L2TP Configuration](#).

### 5.1.5 DHCP

For information on configuring Dynamic Host Configuration Protocol (DHCP), refer to [APN Configuration](#).

### 5.1.6 RADIUS

For information on configuring Remote Authentication Dial-In User Service (RADIUS), refer to [RADIUS Configuration](#).

## 5.2 Event-Based Monitoring

For information on configuring Event-Based Monitoring (EBM), refer to [Event-Based Monitoring Configuration](#).

## 5.3 Quality of Service

For information on configuring Quality of Service (QoS), refer to [Quality of Service Configuration](#).

## 5.4 Resilience

For information on configuring resilience, refer to [EPG Board Configuration](#).

For information on performing scale out procedures, refer to [Scaling the EPG](#).

## 5.5 SACC

The following sections list resources for information on configuring Service Aware Charging and Control (SACC).



### **5.5.1 Content Filtering**

For information on configuring content filtering, refer to [Content Filtering Configuration](#).

### **5.5.2 PISC**

For information on configuring Packet Inspection and Service Classification (PISC), refer to [PISC Configuration](#).

### **5.5.3 Charging Methods**

For information on configuring charging methods, refer to [Charging Methods Configuration](#).

### **5.5.4 Credit Control**

For information on configuring credit control, refer to [Credit Control Configuration](#).

### **5.5.5 Policy and Charging Control**

For information on configuring policy and charging control, refer to [Policy Control Configuration](#).

### **5.5.6 Aware Policy-Based Routing**

For information on configuring Aware Policy-Based Routing, refer to [Aware Policy-Based Routing Configuration](#).

## **5.6 PGW Pause Charging**

For more information on PGW pause charging, refer to [Session Management](#).

For more information on configuring PGW pause charging, refer to [PGW Pause Charging Configuration](#).

## **5.7 Operation and Maintenance**

For information on performing Operation and Maintenance (O&M) procedures, refer to [Operation and Maintenance Configuration](#).



## 5.8 Traffic Redirection

For information on configuring traffic redirection, refer to [Traffic Redirection Configuration](#).

## 5.9 Shared IP Pool

For more information on configuring shared IP pools, refer to [Shared IP Pool Configuration](#).

## 5.10 IMS Emergency Session

For more information on configuring IMS emergency session, refer to [IMS Emergency Session Configuration](#).

## 5.11 Inter-Chassis Redundancy

For more information on configuring Inter-Chassis Redundancy (ICR), refer to [Inter-Chassis Redundancy Configuration](#).

## 5.12 Service Chaining

For information on service chaining configuration, refer to [Service Chaining Configuration](#).

# 6 EPG Configuration Examples

This chapter provides examples of EPG configuration. These examples show configuration of all EPG-related interfaces, addresses, services, APNs, and several other EPG features and capabilities. These examples do not change QoS parameters from the defaults, show routing protocols, nor show configuration of Label-Switched Paths (LSPs) used by Multi-Protocol Label Switching (MPLS).

**Note:** The examples in this section only show, partially, ways that an EPG can be configured. There are other configurations for the Gn, Gi, and additional interfaces for different physical and logical network architectures.



## 6.1 Determine the Network Environment

Before configuring an EPG, first determine the network environment, including all of the physical interfaces on the EPG and the board types.

In this configuration example, the EPG is at the center of a group of conceptual interfaces. The interfaces concerned are listed as below and those not mentioned below are not covered in this document.

- The Gn interface to the SGSN
- The Gi and SGi interfaces to one or more APNs
- The S4 interface to the SGSN
- The S5/S8 interface to an external SGW
- The S5/S8 interface to an external PGW
- The GTP-based S2a interface to a trusted WLAN Access Network (TWAN)
- The PMIPv6-based S2a interface to a Mobile Access Gateway (MAG)
- The S2b interface to an Evolved Packet Data Gateway (ePDG)
- The S11 interface to the MME
- The S1-U interface to the eNodeB
- The S12 interface to the Radio Network Controller (RNC)
- The Ga interface for the charging and billing gateway server
- Gom logical interfaces for O&M
- The SGi interfaces for an external service function in case of service chaining

All of these conceptual interface types are shown in Figure 1.

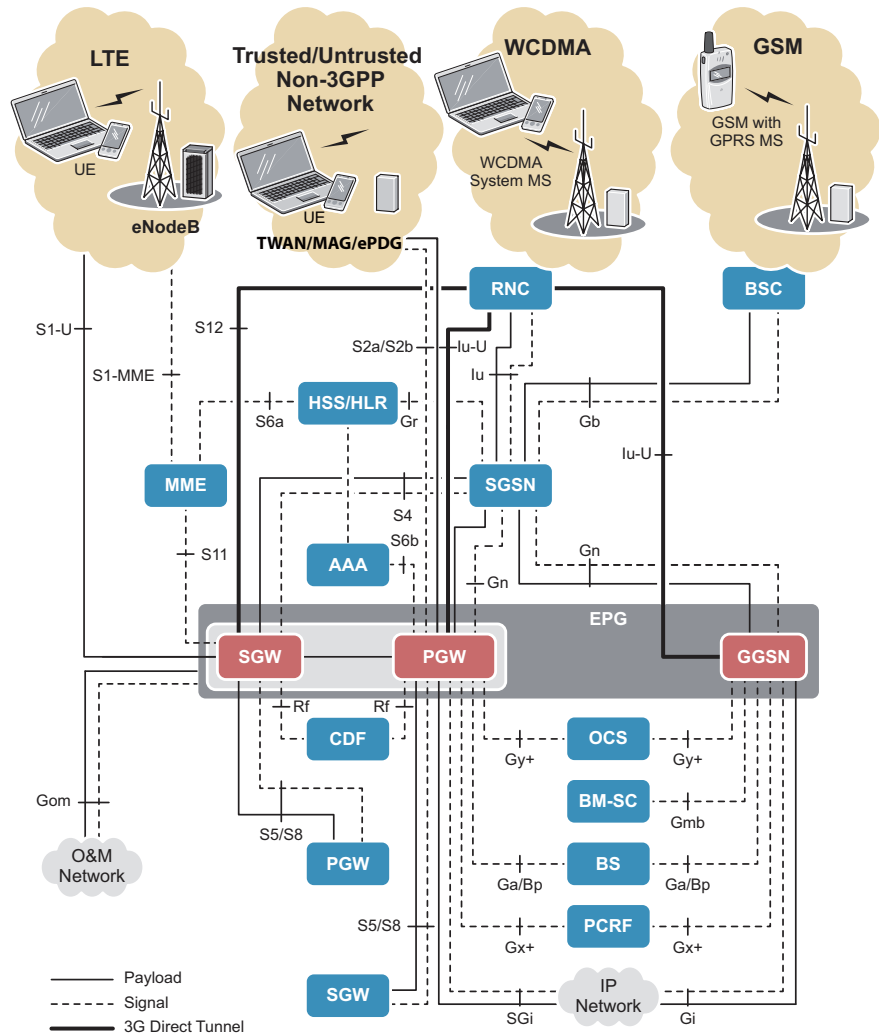

Figure 1 Conceptual EPG Interfaces

Conceptual interfaces are different from logical interfaces, and are not necessarily separate physical interfaces, although they might be in some configurations. More than one conceptual interface can share a single physical interface. However, multiple conceptual interfaces configured on the same physical interface can negatively impact performance. For clarity, this example uses a separate physical interface for each conceptual interface. These physical interfaces are assigned IP addresses in the configuration example.

In addition to the conceptual interfaces and related physical interfaces, this example EPG also configures separate physical interfaces for shared RADIUS and DHCP servers for use by certain APNs.



## 6.2 Determine the IP Addresses

The first task is to configure the correct IP addresses used on the interfaces. This requires coordination between the EPG network administrator and the network administrators of the other network devices and the various APNs. This example uses private IP addresses and is somewhat limited in choice of addresses for different parts of the network. In reality, the IP addresses employed by the EPG would likely be very diverse instead of being drawn from only the 10.0.0.0/8, 172.16.0.0/12 and 192.168.0.0/16 address spaces.

For end-to-end user data transfer between the UE and an APN through the EPG, six IP addresses are important in a GPRS context. Different IP addresses are required in an EPS context and are indicated as such in the list following Figure 2. Control functions also use these IP addresses, but the packet flows are somewhat different and are not illustrated. Figure 2 shows the use of these six IP addresses for data transfer along with the structure of the arriving and departing protocol data units in which the addresses appear for a GPRS example. In an EPS context, the GGSN is replaced by the PGW and the SGSN by the SGW.

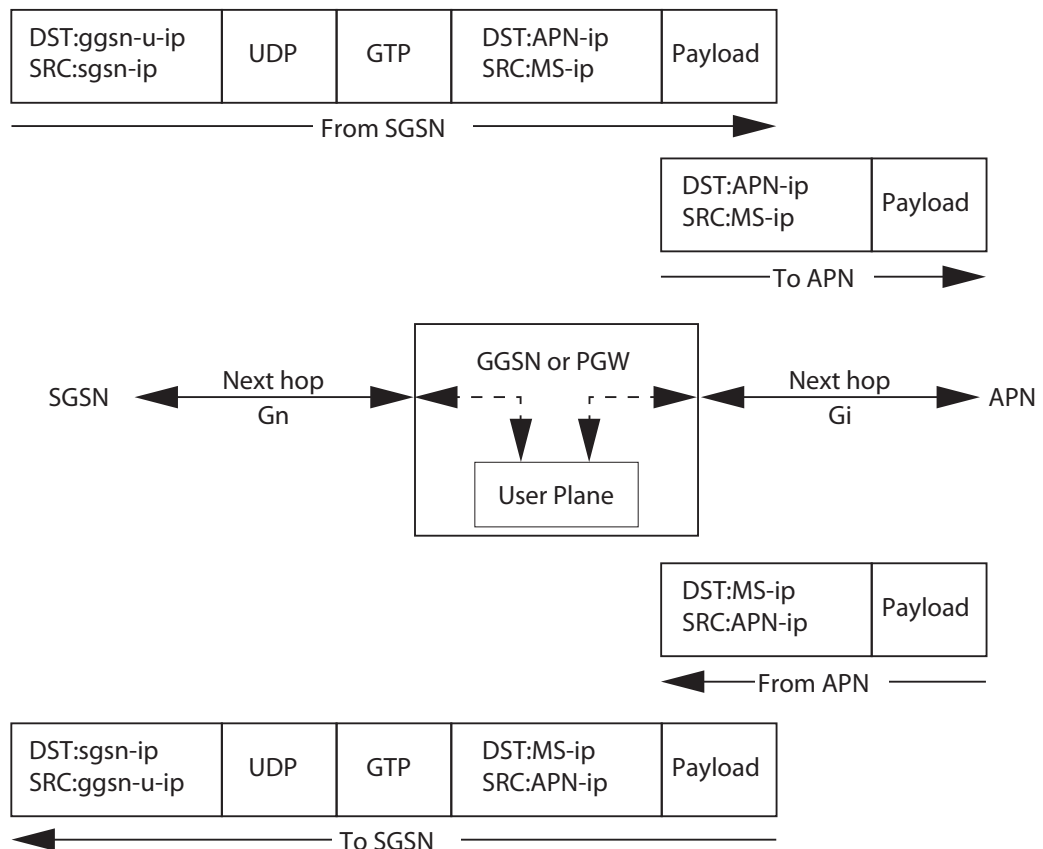

Figure 2 IP Addresses Used for Data Transfer in a GPRS Context

The figure shows the uplink flow of packets from UE through the SGSN and GGSN to the APN and the downlink flow from the APN to the UE. The outer IP header on packets that flow between SGSN and GGSN has the SGSN IP address and the



user plane IP addresses. Packets flow between the SGSN and Packet Processing Boards (PPBs), based on these IP addresses. The inner IP header on packets that flow between the EPG and the APN has the UE IP and APN IP addresses. Packets flow between the UE and the APN device (such as a server) based on these IP addresses. The IP addresses on the physical interfaces on the EPG are used to resolve next-hop addresses for these packets.

The EPG receives or discovers the IP addresses in the following ways:

— Gn/Gp interface

The physical Gn/Gp interface IP address used for next-hop resolution is configured directly on the physical Gn/Gp interface. The Gn/Gp interface is configured using two separate logical interfaces; one for the user plane and one for the control plane. For more information on configuring interfaces and IP addresses, refer to [GTP Interface Configuration](#).

— PGW S5/S8, GTP-based S2a, and S2b interfaces - EPS interface

The physical PGW S5/S8, GTP-based S2a, and S2b interface IP address used for next-hop resolution is configured directly on the physical PGW S5/S8, GTP-based S2a, and S2b interface. The PGW S5/S8, GTP-based S2a, and S2b interfaces are configured using two separate logical interfaces; one for the user plane and one for the control plane. For more information on configuring physical interfaces and IP addresses, refer to [GTP Interface Configuration](#).

— S4-C and S11 - EPS interface

The physical S4-C and S11 interface IP address used for next-hop resolution is configured directly on the physical S4-C and S11 interface. For more information on configuring physical interfaces and IP addresses, refer to [GTP Interface Configuration](#).

— SGW S5/S8 interface - EPS interface

The physical S5/S8 interface IP address used for next-hop resolution are configured directly on the physical S5/S8 interface. The S5/S8 interface is configured using two separate logical interfaces; one for the user plane and one for the control plane. For more information on configuring physical interfaces and IP addresses, refer to [GTP Interface Configuration](#).

— S1-U, S4-U, and S12 interface - EPS interface

The physical S1-U, S4-U, and S12 interface IP address used for next-hop resolution is configured directly on the physical S1-U, S4-U, and S12 interface. For more information on configuring physical interfaces and IP addresses, refer to [GTP Interface Configuration](#).

— Gi and SGi interface

The physical Gi and SGi interface IP address used for next-hop resolution for each APN is configured directly on the particular physical Gi and SGi interface.



For more information on configuring interfaces and IP addresses, refer to [Contexts and Interfaces](#).

The SGi interface is used in the EPS and fulfills the same role as Gi. It is used for PGW-enabled APNs.

When service chaining is used, add the IP address to the interface with SGI service functions, refer to [Service Chaining Configuration](#).

#### — SGSN IP

The IP address of the SGSN is learned by the GGSN when a PDP context is created by the SGSN and GGSN. Because it is part of a control function, no explicit configuration of the SGSN IP address is needed, except when special configuration is required for a particular SGSN.

In an EPS context, the GGSN is replaced by the PGW, SGSN is replaced by the SGW and PDP contexts are replaced by EPS bearers.

#### — APN IP

This IP address space is either learned through a routing protocol, statically configured in the default routing table (`inet.0`), or statically configured as part of the routing instance on that Gi or SGi interface. This example uses static configuration in the routing instances for each Gi or SGi interface. To configure the APN address space, include the `static` statement. For more information on configuring routing instances, refer to [APN Configuration](#).

#### — UE IP

These IP addresses, one for each PDP context or EPS bearer, are configured as a range for each APN and can be assigned a static address, or a dynamic address from a shared IP pool, a RADIUS server, or a DHCP server. All of these methods are used in the various APNs configured in this example network. To configure the UE address space, include the `address` statement or link the shared IP pool to APN.

In this example, the following interfaces are configured:

- Gn, PGW S5/S8, and GTP-based S2a interface
- SGW S5/S8 interface
- S4-C and S11 interface
- S1-U, S4-U, S12 interface
- Gom logical interfaces
- A number of Gi and SGi interfaces

The addresses on the physical Gi and SGi interfaces to the APNs are all drawn from the `20.255.0.0/16` IP address space and the IP addresses assigned to the



UE are all in the 172.16.0.0/12 private IP address space. Because overlapping IP address spaces are used by the UE in this configuration example, each Gi or SGi interface uses a virtual routing instance table in a Virtual Private Network (VPN) to hold routing information. Seven APNs are configured in this example. For simplicity, the APNs are called APN1.com through APN7.com. The major characteristics of each of the seven APNs are as follows:

- APN1.com is on a Gi interface associated to the `vlan-id 1`, using IPv4 address 20.255.59.0/28 and IPv6 address 2001:f040:2::9/62; the UE use IP address range 172.16.1.0/24. The IP addresses for the UE using this APN are assigned a static address by the GGSN, and no RADIUS server is used for authentication and accounting.
- APN2.com is on an SGi interface associated to the `vlan-id 2`, using IP address 20.255.60.0/28 and IPv6 address 2001:f040:3::9/62; the UE use IP address range 172.16.2.0/24. The IP addresses for the UE using this APN are assigned from a shared IP pool by the GGSN, and no RADIUS server is used for authentication and accounting. SACC is enabled and configured for the APN.
- APN3.com is on a Gi interface associated to the `vlan-id 3`, using IP address 20.255.61.0/28 and the UE use IP address range 172.16.3.0/24. This APN uses an inband RADIUS server for authentication and accounting and to assign IP addresses to its UE.
- APN4.com is on a Gi interface associated to the `vlan-id 4`, using IP address 20.255.62.0/28 and the UE use IP address range 172.16.4.0/24. This APN uses an inband DHCP server to assign IP addresses to its UE.
- APN5.com is on a Gi interface associated to the `vlan-id 5`, using IP address 20.255.63.0/28 and the UE use IP address range 172.16.5.0/24. This APN shares a routing instance with APN6.com. This APN uses a shared RADIUS server for authentication and accounting. The UE are assigned a static IP address by the GGSN.
- APN6.com is on a Gi interface associated to the `vlan-id 6`, using IP address 20.255.64.0/28 and the UE use IP address range 172.16.6.0/24. This APN shares a routing instance with APN5.com, so the IP address ranges can no longer overlap. This APN uses a shared RADIUS server for authentication and accounting. The IP addresses are statically assigned to the UE by the EPG.
- APN7.com is on a Gi interface associated to the `vlan-id 7`, using IP address 20.255.65.0/28 and the UE use IP address range 172.16.7.0/24 to show that UE address ranges do not have to overlap. This APN uses a shared DHCP server to assign IP addresses to its UE.

In addition to the Gn, S4-C, S4-U, S5/S8, GTP-based S2a, S2b, S11, S1-U, S12, and Gi or SGi interfaces, the EPG uses addresses from the 192.168/16 private address space for the Gomp, shared RADIUS, and DHCP interfaces.

The IP addresses used in the example are configured in different sections of the EPG configuration file. This configuration example also establishes addresses in



the 192.168/16 range for the node to use as source addresses on packets sent on the Gn, S4-C, S4-U, S5/S8, GTP-based S2a, S2b, S11, S1-U, S12, and Gom interfaces.

## 6.3 Configure Physical Interfaces

This section contains example configuration for contexts, physical interfaces, and Service Chaining using Direct I/O. For more information on configuring physical interfaces and IP addresses, refer to [Contexts and Interfaces](#).

### Create Contexts and Configuring Physical Interfaces

```
contexts service multiple-contexts true
contexts context ctx-s5s8-c
!
contexts context ctx-s5s8-u
!
contexts context ctx-s4s11-c
!
contexts context ctx-s1s4s12-u
!
contexts context ctx-gom-c
!
contexts context ctx-ebm
!
contexts context ctx-rf
!
interfaces interface if-s5s8-c@ctx-s5s8-c
  type ipForward
  l3-interface context ctx-s5s8-c
  l3-interface ipv6 address addr-primary 2a00:11:0:1::254/64
  l3-interface ip address addr-primary addr 11.0.1.254/24
!
interfaces interface if-s5s8-u@ctx-s5s8-u
  type ipForward
  l3-interface context ctx-s5s8-u
  l3-interface ipv6 address addr-primary 2a00:11:0:5::254/64
  l3-interface ip address addr-primary addr 11.0.5.254/24
!
interfaces interface if-s4s11-c@ctx-s4s11-c
  type ipForward
  l3-interface context ctx-s4s11-c
  l3-interface ip address addr-primary addr 11.0.2.254/24
!
interfaces interface if-s1s4s12-u@ctx-s1s4s12-u
  type ipForward
  l3-interface context ctx-s1s4s12-u
  l3-interface ipv6 address addr-primary 2a00:11:0:4::254/64
  l3-interface ip address addr-primary addr 11.0.4.254/24
!
interfaces interface if-gom-c@ctx-gom-c
```



```

type ipForward
l3-interface context ctx-gom-c
l3-interface ipv6 address addr-primary 2a00:11:0:3::254/64
l3-interface ip address addr-primary addr 11.0.3.254/24
!
interfaces interface if-ebm@ctx-ebm
type ipForward
l3-interface context ctx-ebm
l3-interface ipv6 address addr-primary 2a00:11:0:6::254/64
l3-interface ip address addr-primary addr 11.0.6.254/24
!
interfaces interface if-rf@ctx-rf
type ipForward
l3-interface context ctx-rf
l3-interface ipv6 address addr-primary 2a00:11:0:7::254/64
l3-interface ip address addr-primary addr 11.0.7.254/24
!

```

#### Service Chaining Using Direct I/O

```

!
port [local]vepg51-1#show runningconfig
epg node direct-io
epg node direct-i-o logical-port LP-1 port [ 0 ]
!
epg node direct-i-o routing-instance
ROUTING_INSTANCE_DIO_SF link-network-address-range 172.30.0.0/16 logical-port
!

```

## 6.4 Configure EPG Logical Interfaces

This section contains an example of configuration for some EPG logical interfaces.

### Configure SGW Logical Interfaces for S1-U, S4, S11, S5/S8, S12, and Gom Interfaces

```

epg node interface gom-c logical-interface gom-c-if
epg node logical-interface gom-c-if
routing-instance ctx-gom-c
address 192.168.50.9/32
ipv6-address 2001:1b70:4294:ff90::2520/128
!
epg node logical-interface s1s4s12-u-if
routing-instance ctx-s1s4s12-u
ipv6-address 2001:1b70:4294:ffa0::2601/128
!
epg node logical-interface s4s11-c-if
routing-instance ctx-s4s11-c
ipv6-address 2001:1b70:4294:ffa0::2603/128
!
epg node logical-interface s5s8-c-if

```



```
routing-instance ctx-s5s8
address          192.168.50.7/32
ipv6-address     2001:1b70:4294:ffa0::2605/128
!
epg node logical-interface s5s8-u-if
routing-instance ctx-s5s8
address          192.168.50.8/32
ipv6-address     2001:1b70:4294:ffa0::2606/128
!
epg sgw interface s5s8-c logical-interface s5s8-c-if
epg sgw interface s5s8-c t3-response-time 3
epg sgw interface s5s8-c n3-requests 2
epg sgw interface s5s8-c diffserv cs4
epg sgw interface s1s4s12-u logical-interface s1s4s12-u-if
epg sgw interface s4s11-c logical-interface s4s11-c-if
epg sgw interface s4s11-c n3-requests 2
epg sgw interface s4s11-c t3-response-time 3
epg sgw interface s4s11-c diffserv cs4
epg sgw interface s5s8-u logical-interface s5s8-u-if
```

### Configure N3/T3 Per SGW Message Type on S4, S11, and S5/S8 Interfaces

```
epg sgw interface s4s11-c create-bearer-request t3-response-time 0.3
epg sgw interface s4s11-c create-bearer-request n3-requests 5
epg sgw interface s5s8-c echo-request t3-response-time 20
epg sgw interface s5s8-c echo-request n3-requests 2
```

### Configure GGSN/PGW Logical Interfaces for the Gn/Gp, S5/S8, S2a, and S2b Interfaces

```
epg node logical-interface gn-s5s8-c-if
routing-instance ri-gngps5s8s2a
address          192.168.10.17/32
!
epg node logical-interface gn-s5s8-u-if
routing-instance ri-gngps5s8s2a
address          192.168.10.25/32
!
epg pgw interface gn-c logical-interface gn-s5s8-c-if
epg pgw interface gn-u logical-interface gn-s5s8-u-if
epg pgw interface s5s8-c logical-interface gn-s5s8-c-if
epg pgw interface s5s8-u logical-interface gn-s5s8-u-if
```

## 6.5 Configure Other EPG Services

Other EPG services, such as EPG board allocation, EPG node, GGSN/PGW, and SGW identifiers, offline charging, and the APNs can also be configured. EPG boards determine the addresses or address ranges to use for IP packets sent through EPG interfaces towards external nodes. In GGSN APNs and PGW APNs,



UE address ranges, allocation methods, and inband and shared RADIUS and DHCP servers for each APN are configured along with other characteristics. When an APN uses a RADIUS server for authentication and accounting but not address allocation, and there is no DHCP server, the PDP context and EPS bearer must be configured for static or shared-IP-pool address allocation.

The Gi or SGi address range, which is used to assign IP addresses to be used by the control plane for control messages on the Gi or SGi interfaces to and from the APNs uses, for example, a /29 suffix provides a pool of six usable addresses for the control plane. The addresses this example uses are drawn from the 10.200.200.8/29 address space.

Billing information sent to the charging gateway server uses GTP' and establishes tariff times based on day (8:00 AM to 5:00 PM) and night usage.

#### Configure Board Allocation for User Plane, Control Plane, and L2TP

```
epg node board-allocation gc-0/5/1
!
epg node board-allocation gc-0/16/1
!
epg node board-allocation gc-0/17/1
!
epg node board-allocation gu-0/6/1
!
epg node board-allocation gu-0/15/1
!
```

#### Configure the EPG Node Identifier

```
epg node node-name epg1-1
```

#### Configure GGSN/PGW and SGW Identifiers

```
epg pgw node pgw-1
epg sgw node sgw-1
```

#### Configure CDR-Based Charging

```
epg pgw charging charging-format 7
epg pgw charging charging-data-file gtp-prime-data-file activate-on-failure
epg pgw charging gtp-prime path-management
epg pgw charging characteristics default profile0
epg pgw charging characteristics profile2 volume-limit 9000
epg pgw charging characteristics profile2 time-limit 15
epg pgw charging characteristics profile2 transfer-type gtp-prime
epg pgw charging characteristics profile2 gtp-prime gateway [ 8.18.0.1 ]
epg pgw charging characteristics profile0 volume-limit 8000
epg pgw charging characteristics profile0 time-limit 15
epg pgw charging characteristics profile0 transfer-type ftp-pull
epg pgw charging characteristics profile3 volume-limit 10000
epg pgw charging characteristics profile3 time-limit 15
epg pgw charging characteristics profile3 transfer-type gtp-ftp
epg pgw charging characteristics profile3 gtp-prime gateway [ 8.18.0.1 ]
```



```
epg sgw charging charging-format 9
epg sgw charging charging-data-file maximum-size 102400
epg sgw charging charging-data-file maximum-age 20
epg sgw charging charging-data-file local-data-file force-empty-files
epg sgw charging characteristics default-profile 0
epg sgw charging characteristics roaming-based-profile 0
epg sgw charging characteristics ignore-profile-from-serving-node
epg sgw charging characteristics profile 0
  volume-limit 800
  time-limit 15
  change-limit 5
!
```

### Configure Rf Charging (SGW)

```
epg sgw charging rf diameter-application-system das-1
epg sgw charging rf acr-retries 3
epg sgw charging rf service-context-id 5.115.310.10.32251@3gpp.org
epg sgw charging rf acr-attribute charging-gateway-function-host
epg sgw charging rf acr-attribute charging-group-id
epg sgw charging rf acr-attribute connected-info
epg sgw charging charging-format 9
epg sgw charging charging-data-file maximum-size 102400
epg sgw charging charging-data-file maximum-age 20
epg sgw charging charging-data-file local-data-file force-empty-files
epg sgw charging characteristics default-profile 0
epg sgw charging characteristics roaming-based-profile 0
epg sgw charging characteristics ignore-profile-from-serving-node
epg sgw charging characteristics profile 0
  volume-limit 800
  time-limit 15
  change-limit 5
!
```

### Configure Rf Charging (PGW)

```
epg pgw charging rf service-context-id 5.115.310.10.32251@3gpp.org
epg pgw charging charging-format 8
epg pgw charging characteristics default profile0
epg pgw charging characteristics transfer-type rf
epg pgw charging characteristics ignore-profile-from-serving-node
epg pgw charging characteristics profile0 volume-limit 800
epg pgw charging characteristics profile0 time-limit 15
epg pgw charging characteristics profile0 change-limit 5
epg pgw charging characteristics profile0 transfer-type rf
```

### Configure Tariffs Change

```
epg pgw charging tariff-activation 1
  starts 01:45
!
epg pgw charging tariff-activation 2
  starts 07:45
!
```



```
epg pgw charging tariff-activation 3
  starts 13:45
!
epg pgw charging tariff-activation 4
  starts 19:45
!
```

### Configure APN1

APN1.com is on a Gi interface using IPv4 address 20.255.59.0/28 and IPv6 address 2001:f040:2::9/62; the UE use IP address range 172.16.1.0/24. The IP addresses for the UE using this APN are assigned a static address by the GGSN, and no RADIUS server is used for authentication and accounting.

```
epg pgw apn dls-apn3-0104
  access-restrictions radius-assisted-apn-selection
  routing-instance sgi3
  gi-address-range 20.255.59.0/28
  pdp-context creation unblocked
  pdp-context enable-dedicated-bearer
  pdp-context address-allocation radius
  pdp-context address 172.16.1.0/24
!
!
```

### Configure APN2 for the PGW

APN2.com is on an SGi interface using IP address 20.255.60.0/28 and IPv6 address 2001:f040:3::9/62; the UE use IP address range 172.16.2.0/24. The IP addresses for the UE using this APN are assigned from a shared IP pool by the GGSN, and no RADIUS server is used for authentication and accounting. SACC is enabled and configured for the APN.

```
epg pgw apn dls-apn3-0102
  routing-instance sgi3
  gi-address-range 20.255.60.0/28
  pgw-enabled
  allow-rule-space [ A ]
  pdp-context creation unblocked
  pdp-context enable-dedicated-bearer
  pdp-context address-allocation radius
  pdp-context load-distribution granularity 16
  pdp-context address 172.16.2.0/24
!
  service-based-charging control-context 3gpp
  service-based-charging policy-control dynamic gx-profile pcd-pcc-gx-1
  diameter-application-system pcc-gx-1
  rule-space-negotiation
!
  service-based-charging credit-control ro-profile ocs-gy-1
  diameter-application-system ocs-1
  service-context-id 8.32251@3gpp.org
```



```
no-preemptive-reservation
failure failure-action terminate
!
service-based-charging credit-control ro-profile ocs-gy-2
diameter-application-system ocs-2
service-context-id 8.32251@3gpp.org
no-preemptive-reservation
failure failure-action terminate
!
!
```

### Configure APN3 with Inband RADIUS Address Allocation

APN3.com is on a Gi interface using IP address 20.255.61.0/28 and the UE use IP address range 172.16.3.0/24. This APN uses an inband RADIUS server for authentication and accounting and to assign IP addresses to its UE.

```
epg pgw apn dls-apn1-0105
routing-instance sgi1
gi-address-range 20.255.61.0/28
pgw-enabled
pdp-context creation unblocked
pdp-context address-allocation radius
pdp-context address 172.16.3.0/24
!
radius authentication server 10.10.10.10
port 1812
secret $8$Naezc/w23v5piz/tQhuA76nSRWuvzRaUHrQm+oAtzR0=
serverdown-timeout 30
!
radius authentication server 10.10.10.11
port 1812
secret $8$SAmg9xCxZ9GJqQBd1Dd6HmRXvEvyfU36QmNOK+EP3c8=
serverdown-timeout 30
!
radius accounting server 10.10.10.10
port 1813
secret $8$KakVR7RmCszc4P1V5WtVcq27YmFKhHAeI4KFnBCFghk=
serverdown-timeout 30
!
radius accounting server 10.10.10.11
port 1813
secret $8$CB2TEIxvoygPQzb071XdJuALdyxu0BFRwBtGTJPlW7o=
serverdown-timeout 30
!
!
```

### Configure APN4 with Inband DHCP Address Allocation

APN4.com is on a Gi interface using IP address 20.255.62.0/28 and the UE use IP address range 172.16.4.0/24. This APN uses an inband DHCP server to assign IP addresses to its UE.



```

epg pgw apn dls-apn1-0106
  routing-instance sgi1
  gi-address-range 20.255.62.0/28
  pgw-enabled
  pdp-context creation unblocked
  pdp-context address-allocation dhcp-client
  pdp-context address 172.16.4.0/24
  !
  dhcp server 10.20.20.20
  !
  !

```

### Configure APN6 with Shared RADIUS Address Allocation

APN6.com is on a Gi interface using IP address 20.255.64.0/28 and the UE use IP address range 172.16.6.0/24. This APN shares a routing instance with APN5.com, so the IP address ranges can no longer overlap. This APN uses a shared RADIUS server for authentication and accounting. The IP addresses are assigned to the UE by the RADIUS server.

```

epg pgw apn dls-apn1-0107
  routing-instance sgi1
  gi-address-range 20.255.64.0/28
  pgw-enabled
  pdp-context creation unblocked
  pdp-context address-allocation radius
  pdp-context address 172.16.6.0/24
  !
  radius authentication shared-server radauthout-om_cn1
  radius accounting shared-server radaccout-om_cn1
  !

```

### Configure APN7 with Shared DHCP Address Allocation

APN7.com is on a Gi interface using IP address 20.255.65.0/28 and the UE use IP address range 172.16.7.0/24 to show that UE address ranges do not have to overlap. This APN uses a shared DHCP server to assign IP addresses to its UE.

```

epg pgw apn dls-apn1-0108
  routing-instance sgi1
  gi-address-range 20.255.65.0/28
  pgw-enabled
  pdp-context creation unblocked
  pdp-context address-allocation dhcp-client
  pdp-context address 172.16.7.0/24
  !
  dhcp shared-server [ dhcpout-om_cn1 ]
  !

```

### Configure Shared DHCP Server for APN7

```

epg pgw dhcp server dhcpout-om_cn1

```



```
address          [ 192.168.10.10 192.168.10.11 ]
routing-instance om_cn
gi-address-range 20.255.70.0/28
!
epg pgw dhcp server dhcpout-om_cn2
address          [ 192.168.11.10 192.168.11.11 ]
routing-instance om_cn
gi-address-range 20.255.70.32/28
!
```

### Configure Shared RADIUS Server for APN5

```
epg pgw radius server radaccout-om_cn1
address          [ 192.168.20.21 ]
routing-instance om_cn
gi-address-range 20.255.71.32/28
secret          $8$j1C6pX2YFT0e10hAlfTYZR477Xg65dMxQPC0q8SqdKs=
!
epg pgw radius server radauthout-om_cn1
address          [ 192.168.20.20 ]
routing-instance om_cn
gi-address-range 20.255.71.0/28
secret          $8$hLY0MzcJ1Fvgv7f8qd6NuJPt7zGBy6+jff5r8TcgAxQ=
!
```



# Reference List

## Standards

- [1] Internet Engineering Task Force: Request for Comments 1918: Address Allocation for Private Internets, RFC 1918