

**NOKIA**

# **BSC S10.5ED E5 Release Test Results**

**ANSI**

The information in this document is subject to change without notice and describes only the product defined in the introduction of this documentation. This document is intended for the use of Nokia's customers only for the purposes of the agreement under which the document is submitted, and no part of it may be reproduced or transmitted in any form or means without the prior written permission of Nokia. The document has been prepared to be used by professional and properly trained personnel, and the customer assumes full responsibility when using it. Nokia welcomes customer comments as part of the process of continuous development and improvement of the documentation.

The information or statements given in this document concerning the suitability, capacity, or performance of the mentioned hardware or software products cannot be considered binding but shall be defined in the agreement made between Nokia and the customer. However, Nokia has made all reasonable efforts to ensure that the instructions contained in the document are adequate and free of material errors and omissions. Nokia will, if necessary, explain issues which may not be covered by the document.

Nokia's liability for any errors in the document is limited to the documentary correction of errors. NOKIA WILL NOT BE RESPONSIBLE IN ANY EVENT FOR ERRORS IN THIS DOCUMENT OR FOR ANY DAMAGES, INCIDENTAL OR CONSEQUENTIAL (INCLUDING MONETARY LOSSES), that might arise from the use of this document or the information in it.

This document and the product it describes are considered protected by copyright according to the applicable laws.

NOKIA logo is a registered trademark of Nokia Oyj.

Other product names mentioned in this document may be trademarks of their respective companies, and they are mentioned for identification purposes only.

Copyright © Nokia Oyj 2003. All rights reserved.

**Contents**

- 1 Purpose..... 5**
- 2 Release Testing Arrangements ..... 6**
- 3 Test environment ..... 7**
  - 3.1 Network components and software levels ..... 9
- 4 Related documents ..... 10**
- 5 Test logs ..... 11**

**Summary of changes**

Version	Date	Author	Comments
1.1-0	12 May 2003	Marko Drugge	First version

# 1 Purpose

This document presents the Release Testing results including all the findings made during testing. The testing personnel, places and testing times are reported in this document as well.

S10 Release Testing followed the procedure described in a separate document "BSC S10.5 Release Test Plan, ANSI".

The following table summarizes the amount of test cases for each configuration and test case statuses.

Configuration	Nbr of test cases	Passed	Failed	Passed %	SW package
S10 BSC2A – S10.5ED (Local upgrade)	20	20	0	100	S10.5 13.13-0
S10.5 BSC3i – S10.5ED (Remote upgrade)	20	20	0	100	S10.5 13.13-0
S10.5ED E4 BSC2i – S10.5ED E5 (Mini upgrade)	20	20	0	100	S10.5 13.13-0

**GPRS1=1xPCU**

**GPRS2=2xPCU-S/PCU+PCU-S**

**Stability Tests**

**Status**

24 h stability test (BSC2A)	OK	S10.5 13.13-0
-----------------------------	----	---------------

## 2 Release Testing Arrangements

Test Place: Hatanpäänvaltatie 30 / E0 BSC Laboratory

Test Period: From 5-May-03  
To 11-May-03

SW version: S10.5ED 13.13-0

Release Test Group Manager: Pasi Kivimäki

**Test team 1:** Marko Drugge (MDr)

- S10 BSC2A – S10.5ED E5 (Local upgrade)

**Test team 2:** Kari Nyman (KN)

- S10.5 BSC3i S10.5 – S10.5ED (Remote upgrade)

**Test team 3:** Pekka Ikonen (PIk)

S10.5ED E4 BSC2i – S10.5ED E5 (Mini upgrade)

**Test team 4:** Marko Drugge (MDr)

- 24 h stability test with traffic generator (BSC2A)

## 3 Test environment

The release test environment is set up according to figure 2a and 2b. Figure 2a is demonstrating the CS traffic configuration and figure 2b PS traffic configuration.

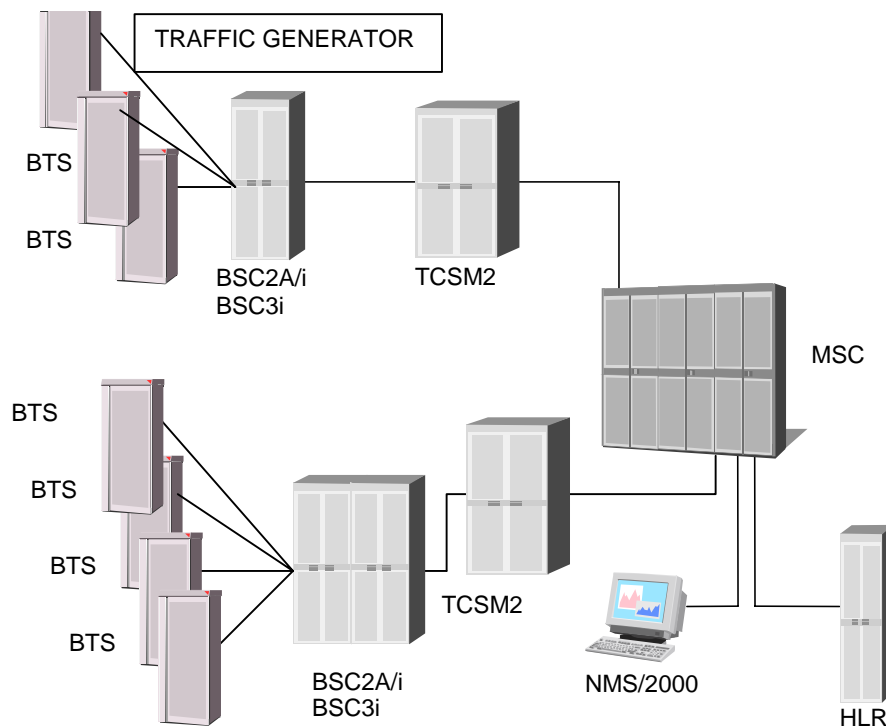

**Figure 2a. Release Test Environment for CS traffic**

The traffic generator is used to produce supervised test traffic for the stability test. A tracer (Protocol Analyser) and a PC are required for tracing the A- and Abis –interfaces in order to verify correct working of the interfaces.

At least two BTSs are connected to BSC for handover tests.

Release tests include the testing of all configuration options on A- and Abis -interfaces. Therefore 16 kbit, 32 kbit and 64 kbit D-channel links must be created on the Abis -interface.

Also, the following special configurations should be taken into account:

The release test configuration must include both the 2<sup>nd</sup>, 3<sup>rd</sup> and 4<sup>th</sup> generation BTSs

The ETs are to be connected so that the whole ET range will be tested, i.e. the first and last ET is in use

At least two TCSM2 units are to be connected to one BSC

All accepted eeprom versions are to be tested during the release testing (one BSC equipped with the newest eeproms, other BSC with a mix of older eeprom versions)

The network configuration must include the whole range of BCFs and BTSs, i.e. the first and last possible BTS and BCF values are used

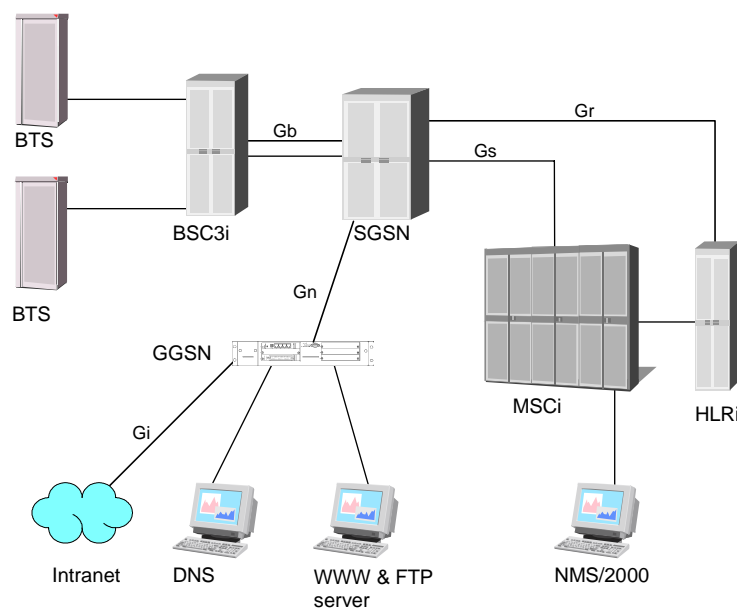

**Figure 2b. Release Test Environment for PS traffic**

## 3.1 Network components and software levels

SW levels of network elements in the test environment must be the following:

DX 200 HLR	SW	M11 6.8-0
DX 200 MSC / VLR	SW	M11 6.8-0
Nokia SGSN	SW	SG2 J2 2.22-0
Nokia Artus SMSC	SW	SC5B.0-24
DX 200 BSC	SW	S10.5 13.13-0
Nokia TCSM	SW	1.10-0
Nokia NMS/2000	SW	T12 03.3 OSS3.1
Ultrasite BTS	SW	CX3.0, CX3.1, CX3.2, CX3.3, CX4.0, PU1.0, PU1E
Metrosite BTS	SW	CXM3.0
PrimeSite BTS	SW	DF6.0, DF7.0
Second generation BTS	SW	B12.0, B13.0, B13.1
Insite BTS	SW	I2.0, I3.0

The feature related compatibilities for individual NE elements are described in the document '*BSS10 Features Under Development*'.

Other Nokia SW release combinations are tested according to BSC Compatibility Test Specification.

# 4

## Related documents

- BSS Integration Manual, Commissioning Manual, 2.2
- DX 200 BSC S10.5 Software Implementation Procedure
- DX200 BSC S10.5 GPRS/EDGE Hardware Implementation Procedure, ANSI
- DX200 BSC And TCSM Hardware Revision List, System Level S8-S10.5
- BSC3i Hardware Revision List, System Level 10.5
- BSS10 Features Under Development
- BSC S10.5 Release Test Cases
- BSC S10.5 Compatibility Test Specification

# 5 Test logs

## Test Team 1 : Local upgrade

### S10 BSC2A + SMLC + GPRS1 → S10.5ED

	TestMan ID	S10.5-S10.5ED Version	Status/Sign
1. Checking BSC & TCSM/TCSM2 HW versions	RT000TC00001	3.1-0	OK/MDr
2. Checking SW levels of other Nes / chapter 4.1	RT000TC00002	3.1-0	OK/MDr
3. Checking installed Change Notes	RT000SW00001	3.1-0	OK/MDr
4. BSC S10.5ED software upgrade	RT000SW00005	1.1-0	OK/MDr
5. BSC system restart	RT000SD00001	2.0-0	OK/MDr
6. Power break in the system	RT000SD00002	1.1-0	OK/MDr
7. OMU state change and diagnostics	RT000SD00003	2.0-0	OK/MDr
8. BCSU state change and diagnostics	RT000SD00004	2.0-0	OK/MDr
9. MCMU state change and diagnostics	RT000SD00005	2.0-0	OK/MDr
10. MB state change and diagnostics	RT000SD00006	2.0-0	OK/MDr
11. Location Update	RT000CC00001	1.0-0	OK/MDr
12. MS to MS call	RT000CC00002	2.0-0	OK/MDr
13. Emergency call	RT000CC00005	1.0-0	OK/MDr
14. Data call	RT000CC00006	2.0-0	OK/MDr
15. SMS from MS to MS	RT000CC00007	1.1-0	OK/MDr
16. Inter cell handover	RT000HO00001	2.0-0	OK/MDr
17. Inter BSC handover S10.5 – S10.5ED	RT000HO00008	1.0-0	OK/MDr
18. Inter BSC handover S10.5ED – S10.5ED	RT000HO00009	1.0-0	OK/MDr
19. Radio resource queuing in handover	RT000HO00004	1.1-0	OK/MDr
20. GPRS call	RT000FE00005	1.0-0	OK/MDr

**Test Team 2 : Remote upgrade**

**S10.5 BSC3i + GPRS2 → S10.5ED**

	TestMan ID	S10.5-S10.5ED	
		Version	Status/Sign
1. Checking BSC & TCSM/TCSM2 HW versions	RT000TC00001	3.1-0	OK/KNy
2. Checking SW levels of other NEs / chapter 4.1	RT000TC00002	3.1-0	OK/KNy
3. Checking installed Change Notes	RT000SW00001	3.1-0	OK/KNy
4. BSC S10.5ED software upgrade	RT000SW00005	1.1-0	OK/KNy
5. BSC system restart	RT000SD00001	2.0-0	OK/KNy
6. Power break in the system	RT000SD00002	1.1-0	OK/KNy
7. OMU state change and diagnostics	RT000SD00003	2.0-0	OK/KNy
8. BCSU state change and diagnostics	RT000SD00004	2.0-0	OK/KNy
9. MCMU state change and diagnostics	RT000SD00005	2.0-0	OK/KNy
10. MB state change and diagnostics	RT000SD00006	2.0-0	OK/KNy
11. Location Update	RT000CC00001	1.0-0	OK/KNy
12. MS to MS call	RT000CC00002	2.0-0	OK/KNy
13. Emergency call	RT000CC00005	1.0-0	OK/KNy
14. Data call	RT000CC00006	2.0-0	OK/KNy
15. SMS from MS to MS	RT000CC00007	1.1-0	OK/KNy
16. Inter cell handover	RT000HO00001	2.0-0	OK/KNy
17. Inter BSC handover S10.5 – S10.5ED	RT000HO00008	1.0-0	OK/KNy
18. Inter BSC handover S10.5ED – S10.5ED	RT000HO00009	1.0-0	OK/KNy
19. Radio resource queuing in handover	RT000HO00004	1.1-0	OK/KNy
20. GPRS call	RT000FE00005	1.0-0	OK/KNy

**Test Team 3 : Mini upgrade**

**S10.5ED E4 BSC2i + SMLC + GPRS2      ->      S10.5ED E5**

	TestMan ID	S10.5-S10.5ED	
		Version	Status/Sign
1. Checking BSC & TCSM/TCSM2 HW versions	RT000TC00001	3.1-0	OK/PIk
2. Checking SW levels of other NEs / chapter 4.1	RT000TC00002	3.1-0	OK/PIk
3. Checking installed Change Notes	RT000SW00001	3.1-0	OK/PIk
4. BSC S10.5ED software upgrade	RT000SW00005	1.1-0	OK/PIk
5. BSC system restart	RT000SD00001	2.0-0	OK/PIk
6. Power break in the system	RT000SD00002	1.1-0	OK/PIk
7. OMU state change and diagnostics	RT000SD00003	2.0-0	OK/PIk
8. BCSU state change and diagnostics	RT000SD00004	2.0-0	OK/PIk
9. MCMU state change and diagnostics	RT000SD00005	2.0-0	OK/PIk
10. MB state change and diagnostics	RT000SD00006	2.0-0	OK/PIk
11. Location Update	RT000CC00001	1.0-0	OK/PIk
12. MS to MS call	RT000CC00002	2.0-0	OK/PIk
13. Emergency call	RT000CC00005	1.0-0	OK/PIk
14. Data call	RT000CC00006	2.0-0	OK/PIk
15. SMS from MS to MS	RT000CC00007	1.1-0	OK/PIk
16. Inter cell handover	RT000HO00001	2.0-0	OK/PIk
17. Inter BSC handover S10.5 – S10.5ED	RT000HO00008	1.0-0	OK/PIk
18. Inter BSC handover S10.5ED – S10.5ED	RT000HO00009	1.0-0	OK/PIk
19. Radio resource queuing in handover	RT000HO00004	1.1-0	OK/PIk
20. GPRS call	RT000FE00005	1.0-0	OK/PIk

**Test Team 4: Stability tests**

**BSC2A + SMLC + GPRS1**

		Version	Status/Sign
1. 24 h stability test with traffic generator (BSC2A)	RT000ST00006	1.1-0	OK/MDr

**RESULTS:**

2 × 24 h stability test with traffic generator

Measurement period:

12-May-03 13:00 -> 14-May-03 13:00

During test execution no serious alarms or disturbances occurred in BSC. No unit restarts occurred during the stability test.

The following results are from BSC measurements after BSC2i stability test:

Call successful: 412426

Call failures: 0

Call failure rate: (0/ 412426)\*100 % = **0 %**

NUM COUNTER	VALUE	NUM COUNTER	VALUE
14	INTERNAL_INTRA_HO_SUCC	3	
16	SETUP_SUCCESSFUL	412480	
18	TCH_SEIZURES	389371	
26	LOCATION_UPDATE	370	
38	ATT_MO_SPEECH_CALL	214097	
43	BASIC_ANSWER_TO_PAGIN	197988	
48	BASIC_IMSI_DETACH	4	
15	CALL_SUCCESSFUL	412426	
17	CONVERSATION_STARTED	375205	
25	ATT_LOCATION_UPDATE	370	
37	ATT_ANSWER_TO_PAGING	198021	
40	ATT_IMSI_DETACH	4	
44	BASIC_MO_SPEECH_CALL	214064	
121	INTRA_DL_INTERF	3	

