

NOKIA

**BSC S10.5ED E5 Release Test Plan
(GSM800 & GSM1900)**

The information in this document is subject to change without notice and describes only the product defined in the introduction of this documentation. This document is intended for the use of Nokia's customers only for the purposes of the agreement under which the document is submitted, and no part of it may be reproduced or transmitted in any form or means without the prior written permission of Nokia. The document has been prepared to be used by professional and properly trained personnel, and the customer assumes full responsibility when using it. Nokia welcomes customer comments as part of the process of continuous development and improvement of the documentation.

The information or statements given in this document concerning the suitability, capacity, or performance of the mentioned hardware or software products cannot be considered binding but shall be defined in the agreement made between Nokia and the customer. However, Nokia has made all reasonable efforts to ensure that the instructions contained in the document are adequate and free of material errors and omissions. Nokia will, if necessary, explain issues which may not be covered by the document.

Nokia's liability for any errors in the document is limited to the documentary correction of errors. **NOKIA WILL NOT BE RESPONSIBLE IN ANY EVENT FOR ERRORS IN THIS DOCUMENT OR FOR ANY DAMAGES, INCIDENTAL OR CONSEQUENTIAL (INCLUDING MONETARY LOSSES)**, that might arise from the use of this document or the information in it.

This document and the product it describes are considered protected by copyright according to the applicable laws.

NOKIA logo is a registered trademark of Nokia Oyj.

Other product names mentioned in this document may be trademarks of their respective companies, and they are mentioned for identification purposes only.

Copyright © Nokia Oyj 2003. All rights reserved.

Contents

1	Purpose	5
2	Minimum S10.5ED upgrade requirements	6
2.1	Minimum S10.5ED SW requirements.....	6
2.1.1	S10 SW level prior to S10.5ED upgrade	6
2.1.2	S10.5 SW level prior to S10.5ED upgrade	6
2.2	Minimum S10.5 HW requirements	6
2.3	Winchester disk space	7
2.4	CPU memory.....	7
3	Test configurations and cases.....	8
3.1	SW upgrades	9
3.2	Stability Tests.....	9
4	Test environment	10
4.1	Network components and software levels.....	11
5	Related documents	13
6	Test logs	14

Summary of changes

Version	Date	Author	Comments
1.0-0	11 Apr 2003	P Kivimaki	First draft version

1 Purpose

This plan contains guidelines for BSC S10.5ED software package release verification. The aim is to check that all the basic functionalities present in the network before the S10.5ED upgrade also remains there after the SW upgrade. The network's basic operational functions are verified through a set of tests, which have been saved in the TestMan database (Lotus Notes application). The remaining functionalities and optional features are tested in BSC system testing phase.

A new BSC software package is upgraded according to the procedure described in the separate document '*DX200 BSC S10.5 Software Implementation Procedure, ANSI, DN02108337*'.

After the upgrade, state transitions and restarts will be tested. The network functionality is tested through location registration, different call cases and handovers. All the call and handover tests are done with real mobile telephone sets. Finally, the stability tests are carried out to verify the traffic transmission capability.

The S10.5ED release test consists of several upgrade configurations covering basic software upgrade (from S10, S10.5 and S10.5ED E4 to S10.5ED E5). The release test environment is described in this plan, together with the required network component SW levels.

2

Minimum S10.5ED upgrade requirements

2.1 Minimum S10.5ED SW requirements

2.1.1 S10 SW level prior to S10.5ED upgrade

It is highly recommended that all the released S10 Change Deliveries (general) are installed in the BSC prior to the S10.5 upgrade. Minimum S10 CD level requirement is BSC S10 Change Delivery **2.0** (general).

Information on published S10 Change Deliveries can be found from NOLS.

2.1.2 S10.5 SW level prior to S10.5ED upgrade

It is highly recommended that all the released S10.5 Change Deliveries (general) must be installed in the BSC prior to the S10.5ED upgrade.

2.2 Minimum S10.5 HW requirements

Before starting the release testing, check the required HW versions of the BSC2A/i and TCSM2 from the document '*DX200 BSC And TCSM Hardware Revisions List, System Level S8- 10.5*'. BSC3i HW versions can be verified from the document '*BSC3i Hardware Revision List, System Level 10.5, CAE 105095*'

2.3 Winchester disk space

Taking into account the recommendation of three SW packages in BSC (S10.5, S10.5ED, a safecopy and space for measurement files), the disk space requirement is altogether 250 MB. The disk space requirement includes all the temporary directories created during the upgrade as well as conversion programs.

2.4 CPU memory

CPU options and minimum acceptable memory requirement in S10.5 are the following:

Second generation BSC2

CPU type	Micro-processor	Memory, Mbytes
CP4HX **	486	64 / 128
CP4HL **	486	64 / 128
CP6LX**	Pentium II	64 / 128
CP6MX *	Pentium III	128

*) With the BSC Optional feature BSS10012, MS Location Services

**) OMU and MCMU with 128 MB memory, BCSU with 64 MB memory

Third generation BSC3i

CPU type	Micro-processor	Memory, Mbytes
CP710_A	Pentium III	256

3 Test configurations and cases

The test configurations in S10.5ED are clearly divided to the three basic SW upgrades. SW upgrade procedures available in S10.5ED is S10, S10.5 and S10.5ED E4 -> S10.5ED E5.

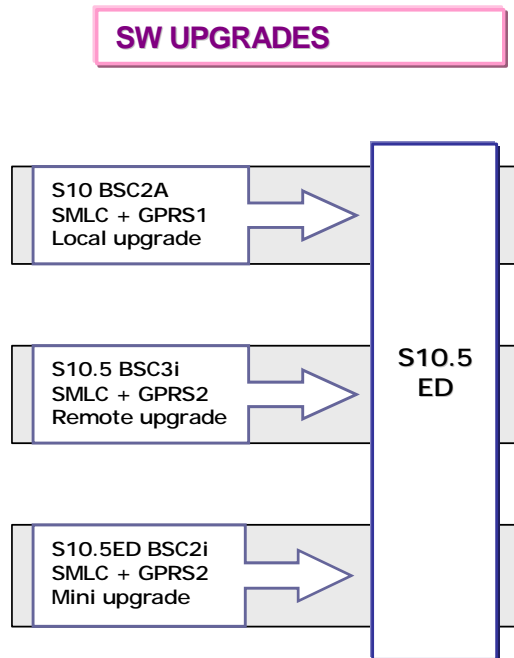

GPRS1=PCU/PCU-S/PCU-T/PCU-B
 GPRS2=2xPCU/2xPCU-S/2xPCU-T/PCU+PCU-S/PCU+PCU-T/PCU-S+PCU-T/2*PCU-B

STABILITY TESTS

Traffic Generator

BSC2A
 SMLC + GPRS1

Figure 1. Release Test configurations.

The release test cases are stored in TestMan, which is a Lotus Notes database for the testware. The test reports are also available in TestMan. Each test group responsible for a certain test configuration fills in the test execution report, which is the basis for upper level test reports. All deviations from the predefined test environment, as well as other observations, should be mentioned in test case comments. To keep track on the release testing, test logs should be available from all the test configurations. In addition to TestMan, release test cases are included in a document *S10.5 Release Test Cases, DN02105604*.

The test cases, which are to be run for a specific test configuration, are listed in chapter 6. The basic tests to be carried out include state transition and restart cases, call cases and handover cases.

3.1 SW upgrades

The S10, S10.5 and S10.5ED E4 to S10.5ED E5 SW upgrade is described in a document '*DX200 BSC S10.5 Software Implementation Procedure, ANSI, DN02108337*'.

Upgrade macros implemented with a PC program HIT (Holistic Integrated Tester) are available for the software upgrades.

3.2 Stability Tests

Stability test is run in traffic generator environment. A 24 h stability test with traffic generator will be carried out for BSC2A. The BSC stability test is used to check the BSC's traffic transmission stability. The traffic generator makes the calls from the Abis-interface through the BSC via real MSC and back to the traffic generator. Calls will be automatically generated and the traffic cases like incoming call, outgoing call, handovers and location update requests are part of testing.

4 Test environment

The release test environment is set up according to figure 2a and 2b. Figure 2a is demonstrating the CS traffic configuration and figure 2b PS traffic configuration.

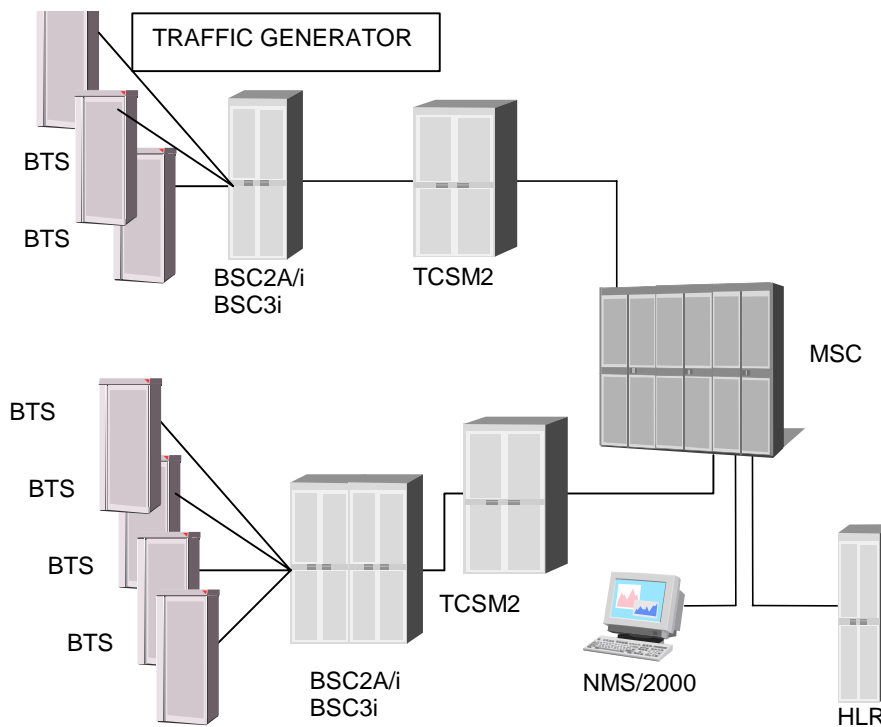

Figure 2a. Release Test Environment for CS traffic

The traffic generator is used to produce supervised test traffic for the stability test. A tracer (Protocol Analyser) and a PC are required for tracing the A- and Abis –interfaces in order to verify correct working of the interfaces.

At least two BTSs are connected to BSC for handover tests.

DX 200 MSC / VLR	SW	M11 6.2-0
Nokia SGSN	SW	SG2 J2 2.22-0
Nokia Artus SMSC	SW	SC5B.0-24
DX 200 BSC	SW	S10.5 13.13-0
Nokia TCSM	SW	1.10-0
Nokia NMS/2000	SW	T12 03.3 OSS3.1
Ultrasite BTS	SW	CX3.0, CX3.1, CX3.2, CX3.3, CX4.0, PU1.0, PU1E
Metrosite BTS	SW	CXM3.0, CX3.2
Talk family BTS	SW	DF6.0, DF7.0
Second generation BTS	SW	B12.0, B13.0, B13.1
Insite BTS	SW	I2.0, I3.0

The feature related compatibilities for individual NE elements are described in the document '*BSS10 Features Under Development*'.

Other Nokia SW release combinations are tested according to BSC Compatibility Test Specification.

5

Related documents

- BSS Integration Manual, Commissioning Manual, 2.2
- DX 200 BSC S10.5 Software Implementation Procedure
- DX200 BSC S10.5 GPRS/EDGE Hardware Implementation Procedure, ANSI
- DX200 BSC And TCSM Hardware Revision List, System Level S8-S10.5
- BSC3i Hardware Revision List, System Level 10.5
- BSS10 Features Under Development
- BSC S10.5 Release Test Cases
- BSC S10.5 Compatibility Test Specification

6 Test logs

Test Team 1 : Local upgrade

S10 BSC2A + SMLC + GPRS1 -> S10.5ED

	TestMan ID	S10.5-S10.5ED Version	Status/Sign
1. Checking BSC & TCSM/TCSM2 HW versions	RT000TC00001	3.1-0	
2. Checking SW levels of other Nes / chapter 4.1	RT000TC00002	3.1-0	
3. Checking installed Change Notes	RT000SW00001	3.1-0	
4. BSC S10.5ED software upgrade	RT000SW00005	1.1-0	
5. BSC system restart	RT000SD00001	2.0-0	
6. Power break in the system	RT000SD00002	1.1-0	
7. OMU state change and diagnostics	RT000SD00003	2.0-0	
8. BCSU state change and diagnostics	RT000SD00004	2.0-0	
9. MCMU state change and diagnostics	RT000SD00005	2.0-0	
10. MB state change and diagnostics	RT000SD00006	2.0-0	
11. Location Update	RT000CC00001	1.0-0	
12. MS to MS call	RT000CC00002	2.0-0	
13. Emergency call	RT000CC00005	1.0-0	
14. Data call	RT000CC00006	2.0-0	
15. SMS from MS to MS	RT000CC00007	1.1-0	
16. Inter cell handover	RT000HO00001	2.0-0	
17. Inter BSC handover S10.5 – S10.5ED	RT000HO00008	1.0-0	
18. Inter BSC handover S10.5ED – S10.5ED	RT000HO00009	1.0-0	
19. Radio resource queuing in handover	RT000HO00004	1.1-0	
20. GPRS call	RT000FE00005	1.0-0	

Test Team 2 : Remote upgrade

S10.5 BSC3i + GPRS2

->

S10.5ED

	TestMan ID	S10.5-S10.5ED	
		Version	Status/Sign
1. Checking BSC & TCSM/TCSM2 HW versions	RT000TC00001	3.1-0	
2. Checking SW levels of other NEs / chapter 4.1	RT000TC00002	3.1-0	
3. Checking installed Change Notes	RT000SW00001	3.1-0	
4. BSC S10.5ED software upgrade	RT000SW00005	1.1-0	
5. BSC system restart	RT000SD00001	2.0-0	
6. Power break in the system	RT000SD00002	1.1-0	
7. OMU state change and diagnostics	RT000SD00003	2.0-0	
8. BCSU state change and diagnostics	RT000SD00004	2.0-0	
9. MCMU state change and diagnostics	RT000SD00005	2.0-0	
10. MB state change and diagnostics	RT000SD00006	2.0-0	
11. Location Update	RT000CC00001	1.0-0	
12. MS to MS call	RT000CC00002	2.0-0	
13. Emergency call	RT000CC00005	1.0-0	
14. Data call	RT000CC00006	2.0-0	
15. SMS from MS to MS	RT000CC00007	1.1-0	
16. Inter cell handover	RT000HO00001	2.0-0	
17. Inter BSC handover S10.5 – S10.5ED	RT000HO00008	1.0-0	
18. Inter BSC handover S10.5ED – S10.5ED	RT000HO00009	1.0-0	
19. Radio resource queuing in handover	RT000HO00004	1.1-0	
20. GPRS call	RT000FE00005	1.0-0	

Test Team 3 : Mini upgrade

S10.5ED E4 BSC2i + SMLC + GPRS2 -> S10.5ED E5

	TestMan ID	S10.5-S10.5ED	
		Version	Status/Sign
1. Checking BSC & TCSM/TCSM2 HW versions	RT000TC00001	3.1-0	
2. Checking SW levels of other NEs / chapter 4.1	RT000TC00002	3.1-0	
3. Checking installed Change Notes	RT000SW00001	3.1-0	
4. BSC S10.5ED software upgrade	RT000SW00005	1.1-0	
5. BSC system restart	RT000SD00001	2.0-0	
6. Power break in the system	RT000SD00002	1.1-0	
7. OMU state change and diagnostics	RT000SD00003	2.0-0	
8. BCSU state change and diagnostics	RT000SD00004	2.0-0	
9. MCMU state change and diagnostics	RT000SD00005	2.0-0	
10. MB state change and diagnostics	RT000SD00006	2.0-0	
11. Location Update	RT000CC00001	1.0-0	
12. MS to MS call	RT000CC00002	2.0-0	
13. Emergency call	RT000CC00005	1.0-0	
14. Data call	RT000CC00006	2.0-0	
15. SMS from MS to MS	RT000CC00007	1.1-0	
16. Inter cell handover	RT000HO00001	2.0-0	
17. Inter BSC handover S10.5 – S10.5ED	RT000HO00008	1.0-0	
18. Inter BSC handover S10.5ED – S10.5ED	RT000HO00009	1.0-0	
19. Radio resource queuing in handover	RT000HO00004	1.1-0	
20. GPRS call	RT000FE00005	1.0-0	

Test Team 4: Stability tests
BSC2A + SMLC + GPRS1

	Status/Sign		Version		
1. 24 h stability test with traffic generator (BSC2A)		RT000ST00006	<table border="1"><tr><td>1.1-0</td><td></td></tr></table>	1.1-0	
1.1-0					

