

DX 200

BSC S10.5 High Capacity Feature Implementation
Procedure

ANSI

NOKIA

The information in this document is subject to change without notice and describes only the product defined in the introduction of this documentation. This document is intended for the use of Nokia Networks' customers only for the purposes of the agreement under which the document is submitted, and no part of it may be reproduced or transmitted in any form or means without the prior written permission of Nokia Networks. The document has been prepared to be used by professional and properly trained personnel, and the customer assumes full responsibility when using it. Nokia Networks welcomes customer comments as part of the process of continuous development and improvement of the documentation.

The information or statements given in this document concerning the suitability, capacity, or performance of the mentioned hardware or software products cannot be considered binding but shall be defined in the agreement made between Nokia Networks and the customer. However, Nokia Networks has made all reasonable efforts to ensure that the instructions contained in the document are adequate and free of material errors and omissions. Nokia Networks will, if necessary, explain issues which may not be covered by the document.

Nokia Networks' liability for any errors in the document is limited to the documentary correction of errors. Nokia Networks WILL NOT BE RESPONSIBLE IN ANY EVENT FOR ERRORS IN THIS DOCUMENT OR FOR ANY DAMAGES, INCIDENTAL OR CONSEQUENTIAL (INCLUDING MONETARY LOSSES), that might arise from the use of this document or the information in it.

This document and the product it describes are considered protected by copyright according to the applicable laws.

NOKIA logo is a registered trademark of Nokia Corporation.

Other product names mentioned in this document may be trademarks of their respective companies, and they are mentioned for identification purposes only.

Copyright © Nokia Networks Oy 2002. All rights reserved.

No. of Pages	Edited by/Translator	Author	Approved by	Previous issue approved
84	30 May 2002 J.Peltomäki	30 May 2002 P. Kivimäki	30 May 2002 P. Kivimäki	

Contents

1	PURPOSE	6
2	FEATURE DESCRIPTION	7
3	PREREQUISITES	9
4	HIGH CAPACITY HW REQUIREMENTS	10
4.1	S10 PLUG-IN UNITS, AS7-X AND CP6MX.....	11
4.2	UPGRADING BSC2A TO BSC2i	11
5	PRELIMINARY STEP	13
5.1	UPGRADE PROCEDURE EXECUTION TIME	13
5.2	THE HOLISTIC INTEGRATED TESTER, HIT	13
5.3	INSTALLING THE HIT-UPGRADE MACRO.....	13
5.4	HIT UPGRADE MACROES.....	14
5.5	INFORMATION FROM CURRENT SOFTWARE.....	14
6	HARDWARE CHANGES	16
6.1	MB UPGRADE - CHANGING MBIF-T TO MBIF-UA.....	17
6.1.1	Database handling	18
6.1.2	MB,1 upgrade.....	19
6.1.3	MB,1 upgrade, MCMU.....	19
6.1.4	MB,1 upgrade, BCSU.....	20
6.1.5	MB,1 upgrade, OMU.....	20
6.1.6	MB,0 upgrade.....	21
6.1.7	MB,0 upgrade, MCMU.....	22
6.1.8	MB,0 upgrade, BCSU.....	22
6.1.9	MB,0 upgrade, OMU.....	23
6.1.10	MCMU SYSB Diagnostics	24
6.1.11	BCSU SYSB Diagnostics	25
6.1.12	OMU SYSB Diagnostics	25
6.2	MCMU UPGRADE.....	26
6.3	BCSU UPGRADE	29
6.3.1	CP6LX / CP6MX CPU Installation.....	29
6.3.2	BSC2A PCU Configuration.....	30
6.3.3	PCU_S Track 8 PCM Configuration in BSC2i.....	31
6.3.4	AS7-VA / AS7-X.....	32
6.3.5	BSC2i AS7_VA /AS7_X Configuration.....	34
6.3.6	DMCT Terminators and BCSU Diagnostics	35
6.4	OMU UPGRADE WITH WDDC CARTRIDGE.....	36
6.4.1	Disable the measurements and observations.....	36
6.4.2	Check measurements	36
6.4.3	Copying databases and files to disk	36
6.4.4	Old OMU HW.....	37
6.4.5	Creation of new HW.....	39
6.4.6	COCEN PIU AND NMS/2000 LAN connection with CP6LX/CP6MX.....	40
6.4.7	Copy EQUIPM database to disk	40
6.4.8	Prevent database and disk updates	41
6.4.9	OMU state change.....	41
6.4.10	Installation of new HW.....	41
6.4.11	CP6LX/CP6MX installation with WDDC SCSI cabling.....	45
6.4.12	Running diagnostics	46
6.4.13	Resume Database and Disk updates.....	47
6.4.14	LAN NMS/2000 links	47

6.4.15 Start Measurements.....	48
7 ET HW UPGRADE.....	49
8 COMPLETION OF THE UPGRADE	53
8.1 IMPLEMENTATION OF THE NEW FEATURE.....	53
8.2 PSFP AND CARTRIDGE MARKING LABELS	53
8.3 ALTERNATIVE VDU AND LPT SETTINGS	53
8.4 TCP/IP SETTINGS FOR LAN CONNECTION.....	54
9 TROUBLESHOOTING	55
9.1 MB- MESSAGEBUS TROUBLESHOOTING	55
9.2 – BCSU UPGRADE TROUBLESHOOTING	55
9.3 – MCMU UPGRADE TROUBLESHOOTING.....	55
9.4 – OMU UPGRADE TROUBLESHOOTING	56
APPENDICES.....	57
APPENDIX 1. DESCRIPTION OF WDDC CARTRIDGE IMPROVEMENT	57
APPENDIX 2. MBIF-UA C 8887 JUMPER SETTINGS	58
APPENDIX 3. CP6LX JUMPER SETTINGS.....	60
APPENDIX 4. CP6MX DIP-SWITCHES.....	62
APPENDIX 5. AS7-VA JUMPER SETTINGS	64
APPENDIX 6. AS7-X JUMPER SETTINGS	66
APPENDIX 7. SW64B JUMPER SETTINGS	69
APPENDIX 8. INSTALLATION OF CARTRIDGES.....	70
APPENDIX 9. SERO-T C 8652 JUMPER SETTINGS	75
APPENDIX 10. ET5C ET CARTRIDGE JUMPER SETTINGS	78
APPENDIX 11. ET2A C 8781 JUMPER SETTINGS	79
APPENDIX 12. WDDC CARTRIDGE JUMPER SETTINGS	81
APPENDIX 13. AS7-US C 8905 JUMPER SETTINGS.....	82
APPENDIX 14. MC1C INTERCHANGEABILITY D	84

Summary of Revisions

Version	Date	Author	Comments
1.0-0	13-Mar-2002	P. Kivimäki	First S10 ANSI version
2.0-0	30-May-2002	J.Peltomäki	First S10.5 ANSI version

1 Purpose

This document describes the implementation of the Nokia DX200 High Capacity BSC feature in S10.5.

Prior to the High Capacity Feature upgrade, the minimum HW requirements for the S10.5 release are met. This brings with it memory upgrade requirements.

High Capacity feature implementation is carried out using the HIT, which is a Microsoft Windows compatible program.

In S10.5 some new hardware items are added to the BSC because of the new features introduced in S10.5. To increase packet processing capacity in S10.5, a new HW configuration may be used by adding a second PCU (PCU-S/PCU_T plug-in unit) to each BCSU unit in BSC2A and in BSC2i. The implementation of second PCU requires also GSWB extension from 192 to 256 PCMs (four SW64B plug-in units in GSWB).

2 Feature description

The S10.5 High Capacity feature is an optional feature for the DX200 Base Station Controller to enhance the growth of the network capacity. The feature enables more powerful and efficient BSC usage by making it possible to create a maximum of 512 TRXs and 248 BTSs/BCFs in BSC2A. The maximum number of air interface traffic channels in one BSC is 4096, this meaning that the sum of full rate, half rate and dual rate channels cannot exceed 512 in one BCSU. The prerequisite is that the BSC fulfills the hardware requirements described in this document.

Note that if the BSC has already S10.5 SMLC feature activated, then the Message Bus and MCMU has been upgraded to high capacity hardware level earlier. MCMU / MB does not require any changes for High Capacity feature, and they can be used as such.

The maximum amount of TRX and BCF objects in a BSC depends on the amount of active BCSU units (BCSU units in WO-EX) state. It is possible to create a maximum of 64 TRX objects under one active BCSU. The amount of BCF objects is 31 under one BCSU. The amount of BTS objects does not depend on the amount of BCSUs. It is always 248 under one High Capacity BSC.

The TRXs, which are numbered 129-512 in a BSC are called Extra TRXs and the number of these is controlled with an Extra TRX Licence. The Extra TRX Licence control is realized in the NMS/2000 T11 and the licence can be used in any BSC fulfilling the HW requirements. The High Capacity Feature does not have limitations on how many BCSU units exist.

BSC2i CPU Hardware includes an Ethernet interface for LAN connections. Thus, BSC2i can be configured for LAN type of NMS connections without any additional hardware. NMS connections of type X.25 are available in the same way as in BSC2A.

A LAN connection to the NMS provides a faster data transmission rate for operation and maintenance use. Instructions for full utilization of available LAN connections are described in the NMS 2000 document: ***DCN Integration manual***.

The CP6LX/CP6MX LAN interface also supports TCP/IP Connections. The TCP/IP protocol suite in DX 200 consists of basic TCP/IP protocol stack and TCP/IP applications, FTP and Telnet. The Telnet in DX 200 enables the user to log in to the DX 200 MMI system across the network from a remote host (e.g. Unix, winNT) over LAN. With the FTP, the disk files can be copied to and from the DX 200, using the remote host asking for the file transfer service.

The DX 200 TCP/IP is compatible with IPv4. The basic protocol stack includes protocols such as TCP, UDP, IP, ICMP, ARP and DNS resolver (client). There are no routing protocols included in the DX 200 TCP/IP, so the user has to define the necessary routing information manually i.e. default routes, when configuring the DX 200 TCP/IP. Additional DX 200 TCP/IP information is available in the S10.5NED, 2.3 Operating Manual, TCP/IP Guide document.

3 Prerequisites

Persons performing the expansion work should have a good knowledge of the DX 200 system and preferably have previous DX 200 BSC expansion experience. The password of the BSC with authority 250 in all command classes and SIM cards of the operator network are needed. It is recommended that a backup is taken from the software package according to the document '*Safecopy Instructions of DX200 BSC*' before installations. This document is included in the S10.5 NED.

Stability of the BSC should be verified, prior to hardware installation work, by checking the alarm history and unit states. Alarm history should be checked for all main computer units. Diagnostics should be executed for all units which are modified during the extension. Change over should be made for all duplicated units. Diagnostics results and alarm history should be analysed to ensure that there are no problems in the BSC.

A wrist band ESD Earthing device or a corresponding method must be used when handling DX 200 hardware equipment.

Installations should be done during periods of low traffic, for example, at night time, to minimize any traffic disturbances. Each stage of the extension work should be commenced only if conditions remain stable. The BSC configuration should be returned to the last stable stage if unsolvable problems are encountered. During the extension work, the alarm situation should be monitored. All alarms which arise must be analysed and the reason for the alarm should be found. The traffic ability of the BSC is checked by testing separate call cases and following up the traffic with traffic specific commands (ZEEL, ZEEI, ZRCI, ZCEL, ZNET). If night time work is done, the operational stability of the BSC should always be checked before leaving the site.

It is recommended that all available S10.5 Change Deliveries be installed to the BSC before the upgrade. The automatic return to old package - feature must not be in use during the upgrade, since the OMU restarts may cause the system to switch the active SW package. The status of the feature can be checked with ZWSI - command.

Subscriber traces must be stopped from the MSC. If subscriber trace is active there is an open observation file in a BSC.

4 High capacity hw requirements

The BSC software release S10.5 High Capacity feature sets requirements for hardware. The capacity increase demands faster calculations, messaging and better overall hardware performance.

The new requirements are met through the introduction of a more efficient CPU (CP6LX/CP6MX), message bus interface (MBIF-UA) and signalling unit (AS7-VA/AS7-X), the BSC2A. The extended need for external PCM circuit interfaces is fulfilled by adding ET5C –cartridges with ET2x plug-in units.

CP6LX/CP6MX has an onboard SCSI –adapter which makes the SCSI –adapter (SCSIF) in the OMU obsolete. CP6LX/CP6MX doesn't provide an MML –interface. This meaning that the SERO PIU is equipped and SCSIF removed with the OMU CPU –upgrade. The service terminal connector type for CP6LX/CP6MX is RJ45 instead of the D25. An adapter cable (CXK003) with D25 female and RJ45 male connectors is available.

The required BSC WDDC cartridge interchangeability level is **B**. Interchangeability **B** must be implemented into BSCs which have been manufactured before week 44/97 (WDDC interchangeability **A**). This retrofit is verified and implemented, if needed, during the upgrade procedure. See section *OMU Upgrade* for additional information.

The interchangeability code B is required for SWADD01. Due to BSC HW Retrofit 9.0, the interchangeability A is not allowed in BSC2A. If the BSC HW Retrofit 9.0 has not yet been implemented, it must be installed before the High Capacity BSC upgrade. See HW Technical note 7/97 for details. BSC factory deliveries with HW Retrofit 9.0 began on week 44/97.

The CP6LX, CP6MX, AS7-X and AS7-VA plug-in unit requires modifications to the current DMC-bus. New DMCT2-S terminators are added to each MC1C cartridge. This changes the interchangeability of MC1C to D. DMCT2-S is required also with PCU- Packet Control Unit plug-in unit. If GRPS -feature has been installed earlier to the BSC, DMCT2-S terminators are found from BCSU units. In this kind of case, add DMCT2-S terminators to the MCMU and OMU cartridges. However, DMCT2-S terminator installation to all MC1C cartridges should be verified during the High Capacity upgrade, so that after the upgrade all cartridges are in interchangeability D – level (material changes: new version of terminator DMCT2-S, code 72724 4001). See HW Product Change Note for Functional Change (CM) of MC1C for details.

If the BSC is equipped with COCEN plug-in units for NMS connection, they must be removed from OMU configuration since CP6LX/CP6MX CPU has a built in LAN interface connection. However, if the LAN cabling used is of coaxial type (with BNC connectors), an adapter or HUB is needed to adapt the coaxial type LAN to the twisted pair (TPI) type of LAN. CP6LX/CP6MX CPU has only the TPI - twisted pair type of LAN connector. If the BSC is equipped with two COCEN PIUs for redundant connection, the redundant LAN connection is not supported in CP6LX/CP6MX in OMU.

4.1 S10 Plug-in units, AS7-X and CP6MX

The AS7-X is a multichannel signalling link terminal for data or signalling using the HDLC format. The capacity of the AS7-X is same as the AS7-VA. The memory architecture in AS7-X pre-processor units is based on the SRAM. Capacity of the AS7-X is as follows:

- 16 CCS7 links or
- 64 LAPD channels or
- digital X.25

AS7-X replaces AS7-VA in High Capacity upgrade deliveries.

The CP6MX CPU is a Mobile Pentium III 500MHz Microprocessor based, single board computer, with an onboard PCI bus and interface to DMC bus, max. 512 MB of SDRAM is accommodated via the DIMMs.

One connection provides option for two lines for the serial port or the service terminal. The use of the two service terminals require a special cable. The DMCT2-S is a Bus Terminator which limits the DMC-bus signal voltage level to 3.5V. The CP6MX and AS7-X units are requiring lower voltage level.

4.2 Upgrading BSC2A to BSC2i

The following picture /1/ shows the necessary HW changes for the second generation BSC. The plug-in units to be changed are:

- OMU
 - MBIF-UAs
 - CP6LX with 64/128 MBytes or CP6MX with 128MBytes of RAM
 - SCSI cabling
 - SCSIT-V terminators
 - SERO-T for LPT and MMIs
 - Q1/LapD terminal changed to AS7-VA or to AS7-X plug-in unit
 - DMCT2-S terminators for DMC bus (at the back of the cartridge, MC1C)
 - new cross-connection brick (PCMCO05, to rearrange PCMs).
 - CBD8, a new panel for 4 LPT + 4 MML interfaces (SERO-T)

- MCMU
 - MBIF-UAs
 - CP6LX with 128 MBytes or CP6MX with 128MBytes of RAM
 - DMCT2-S terminators for DMC bus (at the back of the cartridge, MC1C)
- BCSU
 - MBIF-UAs
 - CP6LX with 64Mbytes of RAM or CP6MX with 128MBytes of RAM
 - AS7-US(s) in every BCSU are replaced with AS7-VA or with AS7-X
 - DMCT2-S terminators for DMC bus (at the back of the cartridge, MC1C)
- SW1C
 - one or two additional SW64 plug-in units in both cartridges
 - front panel connector SWBUS4 with 4th SW64B PIU
 - front panel connector SWBUS3 with 3rd SW64B PIU

Cartridges:
ET5Cs (optional)

Cables:
GSWB -cables for ET2s (with ET5C option)

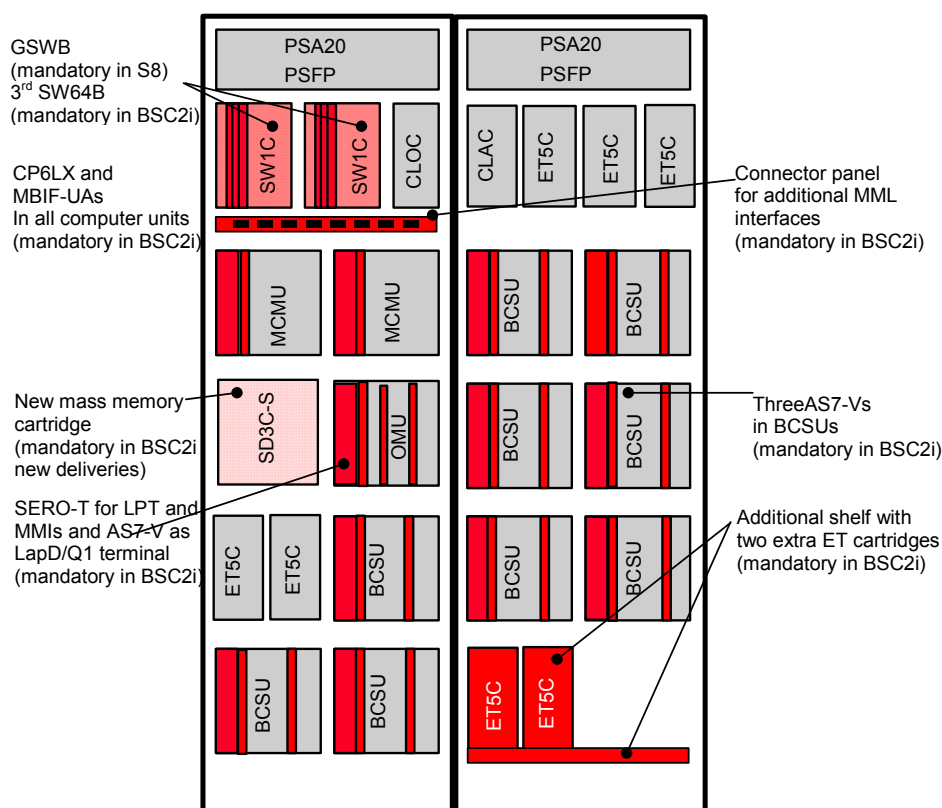

Picture 1. HW requirements and options for BSC2i.

5 Preliminary step

5.1 Upgrade Procedure execution time

Total High Capacity BSC Hardware Upgrade time is 7-8 hours, depending on which options are installed. Execution times for different steps in this procedure are defined later in this manual. Total execution time of 7-8 hours means, that depending on operator's operations and maintenance procedures, upgrade may need to be done in two nights.

If upgrade is done in two nights, it is recommended that in first night whole Messagebus and one BCSU is upgraded. After the upgrade BCSU switchover is made so that particular high capacity HW BCSU is handling signalling link and TRXs. BCSU is monitored during the next day, and if problem appears, BCSU can be switched over to old HW BCSU. In the second night the rest of the HW is installed; BCSUs, MCMUs and OMU.

During the High Capacity BSC upgrade the traffic is handled in a normal way. Only effect to the normal operation is that NMS links are blocked for one hour and measurements are stopped also for one hour.

5.2 The Holistic Integrated Tester, HIT

HIT, the Holistic Integrated Tester program is used in the High Capacity upgrade. Persons performing the expansion work should have a good knowledge of HIT, before starting the upgrade work.

Installation Instructions and details of HIT program are available in HIT documentation. See Document: *HIT 2.3 User Guide*.

5.3 Installing the HIT-Upgrade macro

Install the required upgrading macros. The S10.5 High Capacity upgrading macros are included in the diskette '**HIT Upgrading macros S10.5**'.

Set the following HIT settings on before starting the macro:

1. Options / Interpreter / Recover Errors (tick the box)
2. Options / Environment / Enforce Promptcheck to BOTH (tick the box)
3. Options / Save Settings / default

Directory	File name	Purpose
UPGRADE	UPRHIG10A.LST	S10.5 High Capacity upgrade
BACKUPS10.5	UPRBUP10.HIT	S10.5 software package safecopy

5.4 HIT upgrade macros

In S10.5, high capacity upgrade macros are implemented to the HIT environment. In the S10.5 HIT environment, different phases are divided into the separate HIT macros. This is done to make HIT macro and upgrade procedure more modular and easier to follow. The HIT macro language, TEL, is procedural language (like C) and makes a macro design like a program.

High Capacity upgrade HIT macro modules are executed in HIT's CASE LIST window. UPRHIG10.LST list is executed by either Run Menu (F9) or by the Run icon of the toolbar. If the user wishes to execute only the selected macros from the list, those macros can be marked by clicking the mouse while the CTRL is held down. Alternatively: position the cursor on the item and using the CTRL+UP or CTRL+DOWN arrows to highlight the line. The selected caselist lines are painted green. All the unselected lines are ignored. If no lines are manually selected, the whole caselist is executed as a default. Double clicking an item in the list window causes the macro to be opened in the macro window.

BSC S10.5 High Capacity upgrade HIT macro modules for different phases:

1. UPRHIG10.HIT, **Precheck phase**
2. UPR1HI10.HIT, **MessageBus upgrade phase**
3. UPR2HI10A.HIT, **BCSU upgrade phase**
4. UPR3HI10.HIT, **MCMU upgrade phase**
5. UPR4HI10A.HIT, **OMU, PRFILE and ET upgrade phase**

All the HIT upgrade phases are using their own log file. The Logfile name is asked in the beginning of every upgrade phase. If the used name is already in use, logfile will be appended to the end of the file. However, if user wishes to use single logfile for the whole upgrade, this is possible to do by giving the same logfile name in every phase (instead of default logfile name).

5.5 Information from current software

It is recommended that part of the old S10.5 hardware and software information is printed to the log file.

```
ZUSI ;
ZDDE : OMU : "ZGSC" ;
ZDDE : MCMU , 0 : "ZGSC" ;
ZDDE : MCMU , 1 : "ZGSC" ;
ZWTI : J ;
ZWTI : C ;
ZWTI : U ;
ZWTI : P ;
ZWIP : GSW ;
ZWOO ;
ZEOL ;
ZDSB ;
```

```
ZNET ;  
ZNEL ;  
ZNCI ;  
ZAHO ;  
ZDEB :OMU ;  
ZDBS :BSDATA , 0 ;  
ZDBS :EQUIPM , 0 ;  
ZDBS :OEDATA , 0 ;
```

6 Hardware changes

This section follows the steps in the *UPRHIG10.LST* file. The new hardware is installed and created to the EQUIPM-database.

HW changes are recommended to be made one unit, at a time, but due to incompatibility between CP6LX/CP6MX and MBIF-T PIUs, the MBIF-UAs are to be changed first. The MB-upgrade is then followed by the BCSU, MCMU, OMU and ET HARDWARE upgrades.

The following picture show the rack equipment of BSC2i.

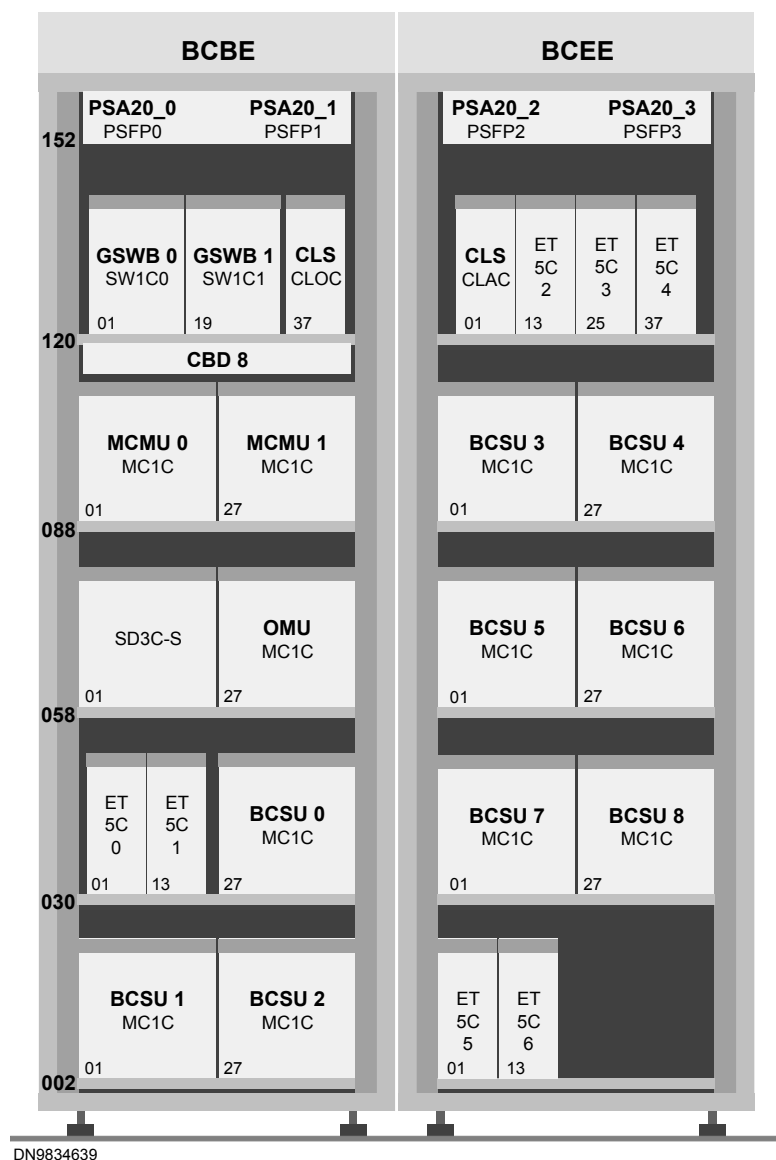

Picture 2. Rack equipment of the DX 200 BSC2i. WDDC cartridges are used instead of SD3C-S in BSC2i's which are upgraded from BSC2A. New BSC2i deliveries are having SD3C-S.

Check that the required amount of plug-in units for the extension are available. It is also recommended to have tested spareparts available. Verify that the plug-in unit interchangeability codes and versions are correct and in accordance with the document *DX200 BSC and TCSM Hardware Revisions List System release S10.5*. This document is delivered in the *S10.5* Software Release binders.

6.1 MB upgrade - Changing MBIF-T to MBIF-UA

This section contains instructions on how to update the message bus interface plug-in units (MBIF-T to MBIF-UA) for every computer unit in DX200 BSC2A with minimal disturbance to the operation of the network element. The execution time of these steps is about 2,5 hours for a fully configured BSC and 1,25 hours for a basic rack (6 Computer units). MBIF cards are replaced one by one in every computer unit.

Note that if the BSC has already S10.5 SMLC feature activated, then the Message Bus has been upgraded to MBIF-UA level earlier. And MB does not require any changes for High Capacity feature.

In the first step, the spare Message Bus is set to SE-NH state. Next, every computer unit is changed to SE-NH state one by one, and MBIF-UA plug-in units are installed to the SE-NH side of the Message Bus in all computer units. Once the plug-in units have been updated to every computer unit, MB diagnostics are performed. After that, MB switchover is executed and a new spare MB is put into SE-NH state. All computer units are then changed to SE-NH state one at a time, and MBIF-UA plug-in units are installed to the other (now in SE-NH state) side of Message bus. In the third phase, computer units are set to TE - state one at a time, and SYSB diagnostics are executed to every computer unit.

During the MB, BCSU and MCMU HW upgrade, Q3 links are not locked. Therefore, network operators must be informed about the HW upgrade work before starting. This is to ensure that no simultaneous BSC commands, which may disturb the upgrade work, are executed from the operating center. Minimizing the Q3 link down time will ensure that the loss of measurements and alarm events are minimized as well. This makes the monitoring of radio network alarms in operating center possible during the upgrade. Measurements and Q3 links are blocked when OMU HW is upgraded.

The CP6LX/CP6MX CPU does not support MBIF-T plug-in units. Therefore, Message Buses are upgraded first. The CP4HX/CP4HL CPU supports both MBIF-T and MBIF-UA plug-in units. After the upgrade, all message bus cards must be of the same type throughout the whole message bus. Every computer unit must contain the same type of MBIF plug-in unit in both message buses.

It is recommended that the operation of the message buses is followed on the day after modification. It is also recommended that a busy hour be included in the system monitoring phase. Both message buses should be up (WO-EX and SP-EX) and no serious alarms should exist in the message or DMC buses during the day.

6.1.1 Database handling

Copy the databases from memory to disks before the MB upgrade changes. This is done to make sure that the latest information is updated to the disks.

```
ZDBC:BSDATA,0;  
ZDBC:OEDATA,0;  
ZDBC:EQUIPM,0;
```

Copy the files:

```
ZDFC:MCMU,<woex_mcmu>;  
ZDFC:OMU;
```

Check that the database states are normal and that they are consistent with both Winchester disks. Check these with commands:

```
ZDBS:BSDATA,0;  
ZDBS:OEDATA,0;  
ZDBS:EQUIPM,0;  
ZDBD:OMU;
```

Make sure that there are no disk updatings in queue.

```
ZDUQ;
```

The values of SIMQUE and SEQQUE must be zero (0).

The manual MB upgrade starts from MB,1. Change the MB,1 to SP-EX state (if it is in some other state):

```
ZUSC:MB,1:SP,;
```

The used MB track numbers and plug-in unit indexes are:

```
MB,0: PIU <index> = 0  
MB,1: PIU <index> = 1  
MB,0: MBIF_UA <track> = 3  
MB,1: MBIF_UA <track> = 4
```

In the MCMUs, the MB upgrade starts from MCMU-0. Change the MCMU,0 to SP-EX state (if it is in some other state):

```
ZUSC:MCMU,0:SP,;
```

In BCSUs, the MB upgrade starts from BCSU-0. Change the BCSU,0 to SP-EX state (if it is in some other state):

```
ZUSC:BCSU,0:SP,;
```

6.1.2 MB,1 upgrade

Change the SP-EX Message Bus 1 to SE-NH state:

```
ZUSC:MB,1:TE,;  
ZUSC:MB,1:SE,;  
ZUSC:MB,1:SE,;
```

6.1.3 MB,1 upgrade, MCMU

Change the SP-EX MCMU state to SE-NH state.

```
ZUSC:MCMU,<SP_EX>:TE,;  
ZUSC:MCMU,<SP_EX>:SE,;  
ZUSC:MCMU,<SP_EX>:SE,;
```

Delete the MBIF-T from the MCMU HW configuration.

```
ZWTQ:MCMU,<SP-EX>:MBIF_T,1;
```

Check that the MBIF-UA plug-in unit strappings are set according to MBIF-UA strapping instructions (see appendix : *MBIF-UA C 8887 Jumper settings*).

Replace the MB,1 MBIF-T plug-in unit with the MBIF-UA in the SE-NH MCMU computer unit. Special attention should be paid to changing the MBIF-UA along the message bus 1 which is in SE-NH state. The front panel lights are switched off in both MBIF-T cards.

Create MBIF-UA to the HW configuration.

```
ZWTP:MCMU,<SP-EX>:MBIF-UA,1,4;
```

Change the MCMU state to SP-EX.

```
ZUSC:MCMU,<SP-EX>:SE,;  
ZUSC:MCMU,<SP-EX>:TE,;  
ZUSC:MCMU,<SP-EX>:SP,;
```

After the MB,1 MBIF-UA is installed in the computer unit, follow the alarm situation from LPT. If any problems are encountered, they must be cleared manually, before continuing the MBIF-UA installation to the next computer unit.

Perform an MCMU Switchover.

```
ZUSC:MCMU,<wo_ex>:SP,;
```

Repeat the steps in section 6.1.3 for another MCMU.

6.1.4 MB,1 upgrade, BCSU

Change the SP-EX BCSU state to SE-NH state:

```
ZUSC:BCSU,<sp_ex>:TE,;  
ZUSC:BCSU,<sp_ex>:SE,;  
ZUSC:BCSU,<sp_ex>:SE,;
```

Delete the MBIF-T from the HW configuration.

```
ZWTQ:BCSU,<sp_ex>:MBIF_T,1;
```

Check that the MBIF-UA plug-in unit strappings are set according to MBIF-UA strapping instructions (see appendix : *MBIF-UA C 8887 Jumper settings*).

Replace the MB,1 MBIF-T plug-in unit with the MBIF-UA in the SE-NH BCSU computer unit. Special attention should be paid to changing the MBIF-UA along the message bus 1 which is in SE-NH state. The front panel light is switched off in both MBIF-T cards.

Create MBIF-UA to the HW configuration.

```
ZWTP:BCSU,<sp_ex>:MBIF-UA,1,4;
```

Change the BCSU state to SP-EX.

```
ZUSC:BCSU,<sp_ex>:SE,;  
ZUSC:BCSU,<sp_ex>:TE,;  
ZUSC:BCSU,<sp_ex>:SP,;
```

After the MB,1 MBIF-UA is installed in the computer unit, follow the alarm situation from LPT. If any problems are encountered, they must be cleared manually, before continuing MBIF-UA installation to the next computer unit.

Make a BCSU switchover.

```
ZUSC:BCSU,<wo_ex>:SP,;
```

Repeat the steps in section 6.1.4 until the MB card has been changed to MBIF-UA through the MB in SE-NH state.

6.1.5 MB,1 upgrade, OMU

Change the OMU state to SE-NH state. Note that the Q3 link is disconnected:

```
ZUSC:OMU:TE;  
ZUSC:OMU:SE;  
ZUSC:OMU:SE;
```

Delete the MBIF-T from the HW configuration.

```
ZWTQ:OMU:MBIF_T,1;
```

Check that the MBIF-UA plug-in unit strappings are set according to MBIF-UA strapping instructions (see appendix : *MBIF-UA C 8887 Jumper settings*).

Replace the MB,1 MBIF-T plug-in unit with the MBIF-UA in the OMU unit. Special attention should be paid to changing the MBIF-UA along the message bus 1 which is in SE-NH state (leds in both MBIF_Ts are on).

Create MBIF-UA to the HW configuration.

```
ZWTP:OMU:MBIF_UA,1,4;
```

Change the OMU state to WO-EX.

```
ZUSC:OMU:SE,;  
ZUSC:OMU:TE,;  
ZUSC:OMU:WO,;
```

After the MB,1 MBIF_UA is installed in the OMU unit, follow the alarm situation from LPT. If any problems are encountered, they must be cleared manually, before continuing to the MB state change.

Change the SE-NH MB,1 state to TE-EX.

```
ZUSC:MB,1:SE,;  
ZUSC:MB,1:TE,;
```

Run diagnostics:

```
ZUDU:MB,1;
```

If the diagnostics fail, follow the procedure described in *Diagnosis Reports manual (2.5 Alarm Reference Manual)*.

Once the diagnostics have been passed, change the MB state to SP-EX.

```
ZUSC:MB,1:SP,;
```

Make a MB switchover.

```
ZUSC:MB,0:SP,;
```

6.1.6 MB,0 upgrade

In BCSUs, the MB upgrade starts from BCSU-0. Change the BCSU,0 to SP-EX state (if it is in some other state):

```
ZUSC:BCSU,0:SP,;
```

Change the SP-EX Message Bus 0 to SE-NH state:

```
ZUSC:MB,0:TE,;  
ZUSC:MB,0:SE,;  
ZUSC:MB,0:SE,;
```

6.1.7 MB,0 upgrade, MCMU

Change the SP-EX MCMU state to SE-NH state:

```
ZUSC:MCMU,<SP_EX>:TE,;  
ZUSC:MCMU,<SP_EX>:SE,;  
ZUSC:MCMU,<SP_EX>:SE,;
```

Delete the MBIF-T from the MCMU HW configuration.

```
ZWTQ:MCMU,<SP-EX>:MBIF_T,0;
```

Check that the MBIF-UA plug-in unit strappings are set according to MBIF-UA strapping instructions (see appendix : *MBIF-UA C 8887 Jumper settings*).

Replace the MB,0 MBIF-T plug-in unit with the MBIF-UA in the SE-NH MCMU computer unit. Special attention should be paid to changing the MBIF-UA along the message bus 0 which is in SE-NH state. The front panel light is switched off in both MBIF-T cards.

Create MBIF-UA to the HW configuration.

```
ZWTP:MCMU,<SP-EX>:MBIF-UA,0,3;
```

Change the MCMU state to SP-EX.

```
ZUSC:MCMU,<SP-EX>:SE,;  
ZUSC:MCMU,<SP-EX>:TE,;  
ZUSC:MCMU,<SP-EX>:SP,;
```

After the MB,0 MBIF-UA is installed in the computer unit, follow the alarm situation from LPT. If any problems are encountered, they must be cleared manually, before continuing the MBIF-UA installation to the next computer unit.

Make an MCMU switchover.

```
ZUSC:MCMU,<wo_ex>:SP,;
```

Repeat the steps in section 6.1.7 for another MCMU.

6.1.8 MB,0 upgrade, BCSU

Change the SP-EX BCSU state to SE-NH state:

```
ZUSC:BCSU,<sp_ex>:TE,;
```

```
ZUSC:BCSU,<sp_ex>:SE,;  
ZUSC:BCSU,<sp_ex>:SE,;
```

Delete the MBIF-T from the HW configuration.

```
ZWTQ:BCSU,<sp_ex>:MBIF_T,0;
```

Check that the MBIF-UA plug-in unit strappings are set according to MBIF-UA strapping instructions (see appendix : *MBIF-UA C 8887 Jumper settings*).

Replace the MB,0 MBIF-T plug-in unit with the MBIF-UA in the SE-NH BCSU computer unit. Special attention should be paid to changing the MBIF-UA along the message bus 0 which is in SE-NH state. The front panel light is switched off in both MBIF-T cards.

Create MBIF-UA to the HW configuration.

```
ZWTP:BCSU,<sp_ex>:MBIF-UA,0,3;
```

Change the BCSU state to SP-EX.

```
ZUSC:BCSU,<sp_ex>:SE,;  
ZUSC:BCSU,<sp_ex>:TE,;  
ZUSC:BCSU,<sp_ex>:SP,;
```

After the MB,0 MBIF-UA is installed in the computer unit, follow the alarm situation from LPT. If any problems are encountered, they must be cleared manually, before continuing the MBIF-UA installation to the next computer unit.

Make a BCSU switchover.

```
ZUSC:BCSU,<wo_ex>:SP,;
```

Repeat the steps in section 6.1.8 until the MB card has been changed to MBIF-UA through the MB in SE-NH state.

6.1.9 MB,0 upgrade, OMU

Change the OMU state to SE-NH state. Note that the Q3 link is disconnected:

```
ZUSC:OMU:TE;  
ZUSC:OMU:SE;  
ZUSC:OMU:SE;
```

Delete the MBIF-T from the HW configuration.

```
ZWTQ:OMU:MBIF_T,0;
```

Check that the MBIF-UA plug-in unit strappings are set according to MBIF-UA strapping instructions (see appendix : *MBIF-UA C 8887 Jumper settings*).

Replace the MB,0 MBIF-T plug-in unit with the MBIF-UA in OMU unit. Special attention should be paid to changing the MBIF-UA along the message bus 0 which is in SE-NH state (leds in both MBIF_Ts are on).

Create MBIF-UA to the HW configuration.

```
ZWTP:OMU:MBIF-UA,0,3;
```

Change the OMU state to WO-EX.

```
ZUSC:OMU:SE,;  
ZUSC:OMU:TE,;  
ZUSC:OMU:WO,;
```

After the MB,0 MBIF-UA is installed in the OMU unit, follow the alarm situation from LPT. If any problems are encountered, they must be cleared manually, before continuing to the MB state change.

Change the SE-NH MB,0 state to TE-EX.

```
ZUSC:MB,0:SE,;  
ZUSC:MB,0:TE,;
```

Run diagnostics:

```
ZUDU:MB,0;
```

If the diagnostics fail, follow the procedure described in *Diagnosis Reports manual (2.5 Alarm Reference Manual)*.

Once the diagnostics have been passed, change the MB state to SP-EX.

```
ZUSC:MB,0:SP,;
```

6.1.10 MCMU SYSB Diagnostics

Change the SP-EX MCMU state to TE- state:

```
ZUSC:MCMU,<SP_EX>:TE,;
```

Run diagnostics:

```
ZUDU:MCMU,<sp_ex>:SYSB;
```

If the diagnostics fail, follow the procedure described in *Diagnosis Reports manual (2.5 Alarm Reference Manual)*.

Change the MCMU state to SP-EX.

```
ZUSC:MCMU,<SP-EX>:SP,;
```

Make an MCMU switchover.

```
ZUSC:MCMU,<wo_ex>:SP,;
```

Repeat the steps in section 6.1.10 for another MCMU.

6.1.11 BCSU SYSB Diagnostics

Change the SP-EX BCSU state to TE- state:

```
ZUSC:BCSU,<sp_ex>:TE,;
```

Run diagnostics:

```
ZUDU:BCSU,<sp_ex>:SYSB;
```

If the diagnostics fail, follow the procedure described in *Diagnosis Reports manual (2.5 Alarm Reference Manual)*.

Change the BCSU state to SP-EX.

```
ZUSC:BCSU,<sp_ex>:SP,;
```

Make a BCSU switchover.

```
ZUSC:BCSU,<wo_ex>:SP,;
```

Repeat the steps in section 6.1.11 until SYSB diagnostics have been executed to every BCSU.

6.1.12 OMU SYSB Diagnostics

Change the OMU state to TE- state. Note that the Q3 link is disconnected:

```
ZUSC:OMU:TE;
```

Run diagnostics:

```
ZUDU:OMU:SYSB;
```

If the diagnostics fail, follow the procedure described in *Diagnosis Reports manual (2.5 Alarm Reference Manual)*. Change the OMU state to WO-EX:

```
ZUSC:OMU:WO,;
```

6.2 MCMU upgrade

The execution time of this step is half an hour. High Capacity hardware is installed by using a MCMU,0 for the HW upgrade and and by making an MCMU switchover. It is recommended that MCMU upgrade is done after the MB upgrade, this is because GSWB can be extended during the procedure. GSWB extension is needed when PCU diagnostics are executed in BCSU step.

Note that if the BSC has already S10.5 SMLC feature activated, then the MCMU CPU has been upgraded to CP6MX level earlier. And MCMU does not require any changes for High Capacity feature.

Implementation of MCMU is shown in the following picture.

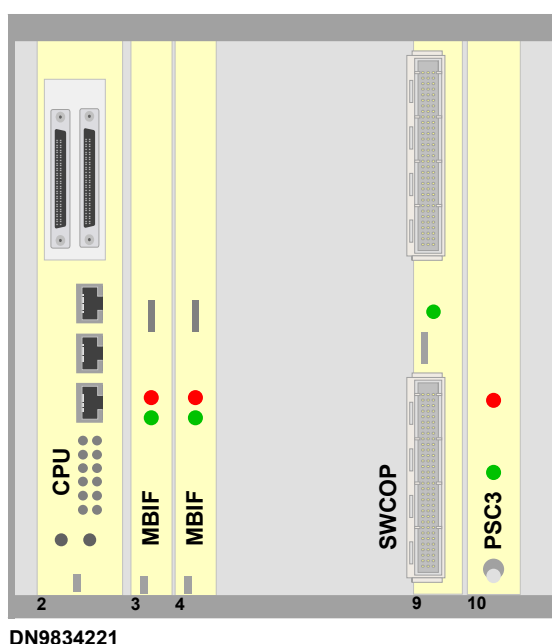

Picture 3. Implementation of the MCMU in BSC2i.

Change the state of the MCMU,0 to SP-EX (The GSWB extension must be installed first to the GSW,0 to ensure that GSWB size is updated to the SWICOP process properly. Proper SWICOP updatings are needed to ensure succesful diagnostics):

```
ZUSC:MCMU,0:SP,;
```

Change the state of the MCMU from SP-EX to state SE-NH.

```
ZUSC:MCMU,<index>:TE,;
ZUSC:MCMU,<index>:SE,;
ZUSC:MCMU,<index>:SE,;
```

Switch the MCMU cartridge power off from the PSC3 power supply.

Check the MCMU hardware with command:

```
ZWTI:P:MCMU,<index>;
```

Delete the old CPU plug-in unit (CP4HX or CP4HL):

```
ZWTQ:MCMU,<index>:<CPU_type>,0;
```

Set the CP6LX /CP6MX strappings according to the instructions in appendix 3 and 4. Replace the CPU plug-in unit with CP6LX/CP6MX.

Create a CPU plug-in unit:

```
ZWTP:MCMU,<index>:CP6LX,0,2; or ZWTP:MCMU,<index>:CP6MX,0,2;
```

It is also possible to expand the GSWB in BSC2i for GPRS/EGPRS (optional feature) use at the same time as upgrading the MCMU in the high capacity upgrade.

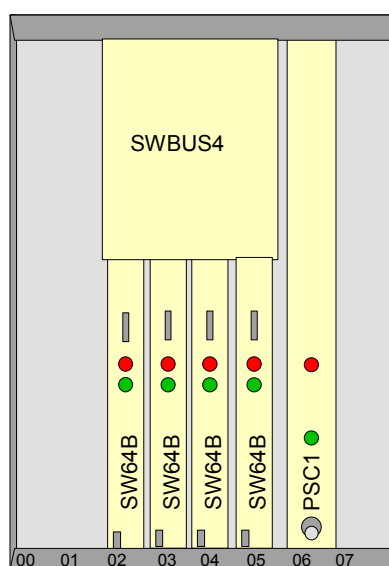

Picture 4. The SW1C cartridge for the GSWB application in BSC2i.

Set the SW64B strappings according to appendix. Install the plug-in unit(s) to the SE-NH MCMU's SW1C cartridge. Switch the GSWB cartridge power off from the PSC1 power supply before installing HW. Switch the power on again after the GSWB HW is installed.

Create an SW64B plug-in unit(s). Third SW64B is required for first PCU plug-in unit in BCSU track 9. The Fourth SW64B is needed, if second PCU/PCU_S is used in BSC2A/BSC2I BCSUs:

```
ZWTP:GSW,<index>:SW64B,2,4;
```

ZWTP:GSW,<index>:SW64B,3,5;

Install a SWBUS3/4 bus extender to GSWB. Install a DMCT2-S DMC-bus terminator at the back of the MCMU MC1C-cartridge. The termination block is equipped to both ends of the MC1C DMC-bus in positions R00 and R09 at the back of the cartridge. Update the interchangeability of MC1C to D. Cover the old code from the interchangeability label by using a drawing pen or replace a label when only one interchangeability code is printed on the label.

Switch the MCMU cartridge power on from the PSC3 power supply.

Change the MCMU state to TE-EX.

ZUSC:MCMU,<index>:SE,;
ZUSC:MCMU,<index>:TE,;

Run diagnostics.

ZUDU:MCMU,<index>;

If diagnostics fail, follow the steps described in **Diagnosis Reports (2.5 Alarm Reference Manual)** manual. Once the diagnostics have been passed, change the MCMU state to SP-EX.

ZUSC:MCMU,<index>:SP,;

Make an MCMU switchover.

ZUSC:MCMU,<wo_index>:SP,;

Repeat these steps for another MCMU.

6.3 BCSU upgrade

The execution time of this step is ten (10) minutes per BCSU. Thus, a fully configured BSC (1+8 BCSU) BCSU upgrade step takes approximately 1,5 hours. High Capacity hardware is installed using a spare BCSU for the HW upgrade and by making BCSU switchovers until every unit is upgraded.

First, change the BCSU state from SP-EX to SE-NH.

```
ZUSC:BCSU,<index>:TE,;  
ZUSC:BCSU,<index>:SE,;  
ZUSC:BCSU,<index>:SE,;
```

Switch the BCSU cartridge power off from the PSC3 power supply.

6.3.1 CP6LX / CP6MX CPU Installation

To change CP6LX/CP6MXs, first check the BCSU hardware with command:

```
ZWTI:P:BCSU,<index>;
```

Delete the old CPU plug-in unit (CP4HX or CP4HL):

```
ZWTQ:BCSU,<index>:<CPU_type>,0;
```

Set the CP6LX/CP6MX jumper settings according to the instructions (see appendixes for *CP6LX/CP6MX*). Replace the CPU plug-in unit with CP6LX/CP6MX (see picture). Create a CPU plug-in unit:

```
ZWTP:BCSU,<index>:CP6LX,0,2; or ZWTP:BCSU,<index>:CP6MX,0,2;
```

6.3.2 BSC2A PCU Configuration

S10.5 BSC2A configuration with two PCUs:

In BSC2A the second PCU/PCU_S plug-in unit might be installed to the BCSU

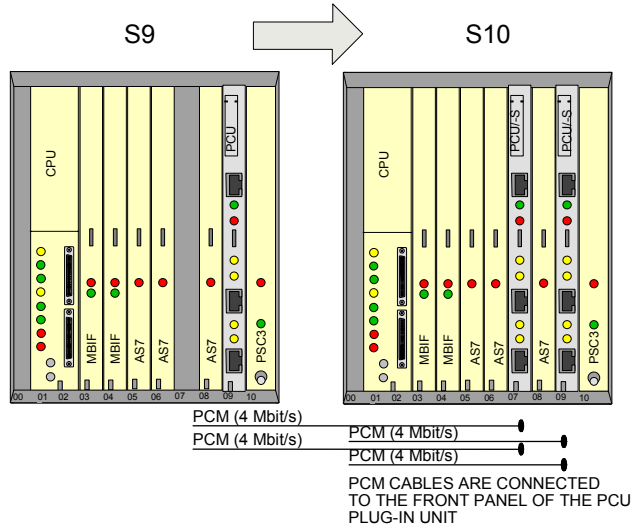

track 7. In the High Capacity BSC configuration 2nd PCU is installed into the track 8. This is why some PCU reconfigurations are required.

S10.5 BSC2i configuration with two PCUs:

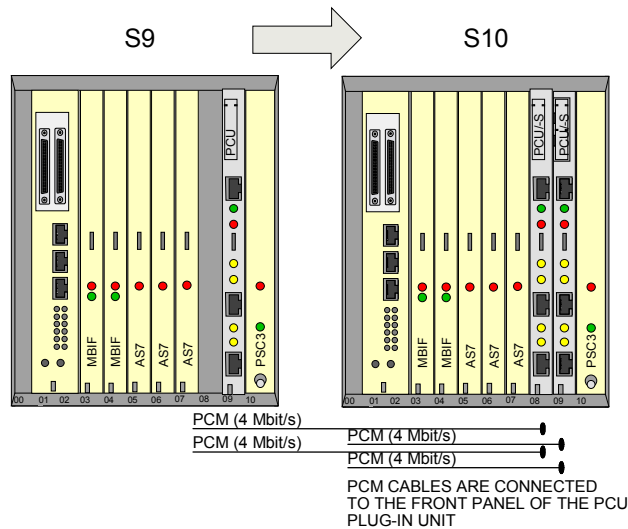

Delete and disconnect the PCU plug-in unit from track 7:

```
ZWUD:BCSU,<index>:PCU_S,2; or ZWUD:BCSU,<index>:PCU,2;
ZWTQ:BCSU,<index>:PCU_S,2; or ZWTQ:BCSU,<index>:PCU_S,2;
```

Remove the PCU plug-in unit.

6.3.3 PCU_S Track 8 PCM Configuration in BSC2i

Install the PCU/ PCU_S to BCSU track 8 (remove AS7_US from track 8). Connect two internal 4M PCM cables (cables which are coming from the GSWB) to the PCU_S. See cable lists for details. The PCU plug-in unit is recreated to the EQUIPM database with the following MML-command:

```
ZWTP:BCSU,0:PCU_S,3,8::PCUDSP,4,152,TSL,0&&31:PCUDSP,4,153,TSL,0&&31:PCUPPC,4,154,TSL,0&&31:PCUPPC,4,155,TSL,0&&31;
```

```
ZWTP:BCSU,1:PCU_S,3,8::PCUDSP,4,192,TSL,0&&31:PCUDSP,4,193,TSL,0&&31:PCUPPC,4,194,TSL,0&&31:PCUPPC,4,195,TSL,0&&31;
```

```
ZWTP:BCSU,2:PCU_S,3,8::PCUDSP,4,196,TSL,0&&31:PCUDSP,4,197,TSL,0&&31:PCUPPC,4,198,TSL,0&&31:PCUPPC,4,199,TSL,0&&31;
```

```
ZWTP:BCSU,3:PCU_S,3,8::PCUDSP,4,200,TSL,0&&31:PCUDSP,4,201,TSL,0&&31:PCUPPC,4,202,TSL,0&&31:PCUPPC,4,203,TSL,0&&31;
```

```
ZWTP:BCSU,4:PCU_S,3,8::PCUDSP,4,204,TSL,0&&31:PCUDSP,4,205,TSL,0&&31:PCUPPC,4,206,TSL,0&&31:PCUPPC,4,207,TSL,0&&31;
```

```
ZWTP:BCSU,5:PCU_S,3,8::PCUDSP,4,208,TSL,0&&31:PCUDSP,4,209,TSL,0&&31:PCUPPC,4,210,TSL,0&&31:PCUPPC,4,211,TSL,0&&31;
```

```
ZWTP:BCSU,6:PCU_S,3,8::PCUDSP,4,212,TSL,0&&31:PCUDSP,4,213,TSL,0&&31:PCUPPC,4,214,TSL,0&&31:PCUPPC,4,215,TSL,0&&31;
```

```
ZWTP:BCSU,7:PCU_S,3,8::PCUDSP,4,216,TSL,0&&31:PCUDSP,4,217,TSL,0&&31:PCUPPC,4,218,TSL,0&&31:PCUPPC,4,219,TSL,0&&31;
```

```
ZWTP:BCSU,8:PCU_S,3,8::PCUDSP,4,220,TSL,0&&31:PCUDSP,4,221,TSL,0&&31:PCUPPC,4,222,TSL,0&&31:PCUPPC,4,223,TSL,0&&31;
```

After the PCU hardware has been created, connect the functional unit.

```
ZWUC:BCSU,<index>:PCU_S,3;
```

BSC2i PCU track 8 PCM-Cables, Cable list for BCBE rack:

No.	Rack	FE	Connector	Rack	FE	Connector	Type	Use
1.110	BCBE	BCSU 0 / PCU	030.27F 08R1	BCBE	SW1C 0	120.01B 04R7	CFN020	PCM
1.111	BCBE	BCSU 0 / PCU	030.27F 08R3	BCBE	SW1C 1	120.19B 04R7	CFN018	PCM
1.112	BCBE	BCSU 1 / PCU	002.01F 08R1	BCBE	SW1C 0	120.01B 05R1	CFN026	PCM
1.113	BCBE	BCSU 1 / PCU	002.01F 08R3	BCBE	SW1C 1	120.19B 05R1	CFN024	PCM
1.114	BCBE	BCSU 2 / PCU	002.27F 08R1	BCBE	SW1C 0	120.01B 05R2	CFN024	PCM
1.115	BCBE	BCSU 2 / PCU	002.27F 08R3	BCBE	SW1C 1	120.19B 05R2	CFN022	PCM

Cable list for BCEE rack:

No.	Rack	FE	Connector	Rack	FE	Connector	Type	Use
2.120	BCEE	BCSU 3 / PCU	088.01F 08R1	BCBE	SW1C 0	120.01B 05R3	CFN016	PCM
2.121	BCEE	BCSU 3 / PCU	088.01F 08R3	BCBE	SW1C 1	120.19B 05R3	CFN014	PCM
2.122	BCEE	BCSU 4 / PCU	088.27F 08R1	BCBE	SW1C 0	120.01B 05R4	CFN018	PCM
2.123	BCEE	BCSU 4 / PCU	088.27F 08R3	BCBE	SW1C 1	120.19B 05R4	CFN016	PCM
2.124	BCEE	BCSU 5 / PCU	058.01F 08R1	BCBE	SW1C 0	120.01B 05R5	CFN024	PCM
2.125	BCEE	BCSU 5 / PCU	058.01F 08R3	BCBE	SW1C 1	120.19B 05R5	CFN022	PCM
2.126	BCEE	BCSU 6 / PCU	058.27F 08R1	BCBE	SW1C 0	120.01B 05R6	CFN022	PCM
2.127	BCEE	BCSU 6 / PCU	058.27F 08R3	BCBE	SW1C 1	120.19B 05R6	CFN020	PCM
2.128	BCEE	BCSU 7 / PCU	030.01F 08R1	BCBE	SW1C 0	120.01B 05R7	CFN028	PCM
2.129	BCEE	BCSU 7 / PCU	030.01F 08R3	BCBE	SW1C 1	120.19B 05R7	CFN026	PCM
2.130	BCEE	BCSU 8 / PCU	030.27F 08R1	BCBE	SW1C 0	120.01B 05R8	CFN026	PCM
2.131	BCEE	BCSU 8 / PCU	030.27F 08R3	BCBE	SW1C 1	120.19B 05R8	CFN024	PCM

¼ EURO Connector is connected to PCU card and 1/8 EURO to the GSWB.

6.3.4 AS7-VA / AS7-X

When changing AS7-USs to AS7-VAs or to AS7-X, first disconnect the functional units. The commands are based on the existing configuration (see the printout).

```
ZWTI:P:BCSU,<index>;
```

```
ZWUD:BCSU,<index>:AS7_U,0;
ZWUD:BCSU,<index>:AS7_U,1;
ZWUD:BCSU,<index>:AS7_U,3;
```

Delete the AS7-USs from the equipment database.

```
ZWTQ:BCSU,<index>:AS7_U,0;
ZWTQ:BCSU,<index>:AS7_U,1;
ZWTQ:BCSU,<index>:AS7_U,3;
```

Check that AS7-VA/AS7-X plug-in unit jumpers are set according to instructions (see appendixes for *the AS7-VA/AS7-X*).

Install the AS7-VAs to BCSU tracks 5, 6 and 7.

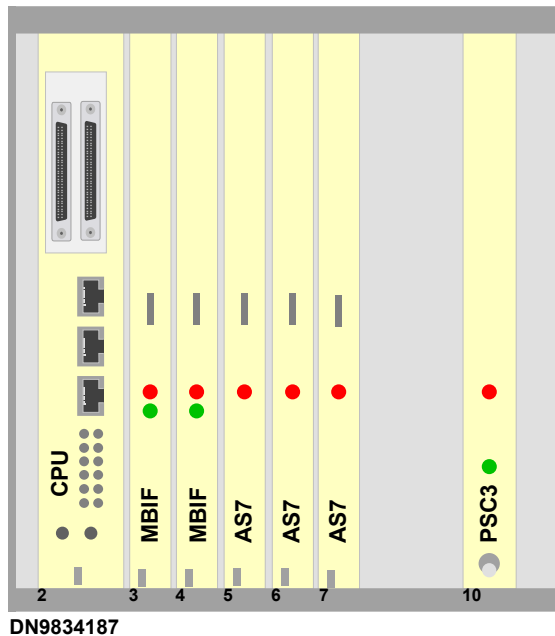

Picture 5. Implementation of the BCSU in BSC2i (without PCU plug-in units).

6.3.5 BSC2i AS7_VA /AS7_X Configuration

From the following printout, select the right command depending on the BCSU index. Create AS7-VA plug-in units. If AS7-X is used instead of the AS7-VA, change the corresponding parameter to the AS7_X:

```

***** BCSU-0 *****
;*****
ZWTP:BCSU,0:AS7_VA,0,5::CCS7,4,4,TSL,0&&3;
ZWTP:BCSU,0:AS7_VA,1,6::LAPD,4,4,TSL,4&&31:LAPD,4,5,TSL,0&&31;
ZWTP:BCSU,0:AS7_VA,2,7::LAPD,4,6,TSL,0&&31:LAPD,4,7,TSL,0&&31;

; ***** BCSU-1 *****
;*****
ZWTP:BCSU,1:AS7_VA,0,5::CCS7,4,8,TSL,0&&3;
ZWTP:BCSU,1:AS7_VA,1,6::LAPD,4,8,TSL,4&&31:LAPD,4,9,TSL,0&&31;
ZWTP:BCSU,1:AS7_VA,2,7::LAPD,4,10,TSL,0&&31:LAPD,4,11,TSL,0&&31;

; ***** BCSU-2 *****
;*****
ZWTP:BCSU,2:AS7_VA,0,5::CCS7,4,12,TSL,0&&3;
ZWTP:BCSU,2:AS7_VA,1,6::LAPD,4,12,TSL,4&&31:LAPD,4,13,TSL,0&&31;
ZWTP:BCSU,2:AS7_VA,2,7::LAPD,4,14,TSL,0&&31:LAPD,4,15,TSL,0&&31;

; ***** BCSU-3 *****
;*****
ZWTP:BCSU,3:AS7_VA,0,5::CCS7,4,16,TSL,0&&3;
ZWTP:BCSU,3:AS7_VA,1,6::LAPD,4,16,TSL,4&&31:LAPD,4,17,TSL,0&&31;
ZWTP:BCSU,3:AS7_VA,2,7::LAPD,4,18,TSL,0&&31:LAPD,4,19,TSL,0&&31;

; ***** BCSU-4 *****
;*****
ZWTP:BCSU,4:AS7_VA,0,5::CCS7,4,20,TSL,0&&3;
ZWTP:BCSU,4:AS7_VA,1,6::LAPD,4,20,TSL,4&&31:LAPD,4,21,TSL,0&&31;
ZWTP:BCSU,4:AS7_VA,2,7::LAPD,4,22,TSL,0&&31:LAPD,4,23,TSL,0&&31;

; ***** BCSU-5 *****
;*****
ZWTP:BCSU,5:AS7_VA,0,5::CCS7,4,24,TSL,0&&3;
ZWTP:BCSU,5:AS7_VA,1,6::LAPD,4,24,TSL,4&&31:LAPD,4,25,TSL,0&&31;
ZWTP:BCSU,5:AS7_VA,2,7::LAPD,4,26,TSL,0&&31:LAPD,4,27,TSL,0&&31;

; ***** BCSU-6 *****
;*****
ZWTP:BCSU,6:AS7_VA,0,5::CCS7,4,28,TSL,0&&3;
ZWTP:BCSU,6:AS7_VA,1,6::LAPD,4,28,TSL,4&&31:LAPD,4,29,TSL,0&&31;
ZWTP:BCSU,6:AS7_VA,2,7::LAPD,4,30,TSL,0&&31:LAPD,4,31,TSL,0&&31;

; ***** BCSU-7 *****
;*****
ZWTP:BCSU,7:AS7_VA,0,5::CCS7,4,64,TSL,0&&3;
ZWTP:BCSU,7:AS7_VA,1,6::LAPD,4,64,TSL,4&&31:LAPD,4,65,TSL,0&&31;
ZWTP:BCSU,7:AS7_VA,2,7::LAPD,4,66,TSL,0&&31:LAPD,4,67,TSL,0&&31;

; ***** BCSU-8 *****
;*****
ZWTP:BCSU,8:AS7_VA,0,5::CCS7,4,68,TSL,0&&3;
ZWTP:BCSU,8:AS7_VA,1,6::LAPD,4,68,TSL,4&&31:LAPD,4,69,TSL,0&&31;
ZWTP:BCSU,8:AS7_VA,2,7::LAPD,4,70,TSL,0&&31:LAPD,4,71,TSL,0&&31;

```

6.3.6 DMCT Terminators and BCSU Diagnostics

After the AS7-VA/AS7-X hardware has been created, connect the functional unit.

```
ZWUC:BCSU,<index>:AS7_VA,0; or      ZWUC:BCSU,<index>:AS7_X,0;  
ZWUC:BCSU,<index>:AS7_VA,1; or      ZWUC:BCSU,<index>:AS7_X,1;  
ZWUC:BCSU,<index>:AS7_VA,2; or      ZWUC:BCSU,<index>:AS7_X,2;
```

<index> =number of the BCSU

Install DMCT2-S DMC-bus terminators at the back of the BCSU MC1C-cartridge. The termination block is equipped to both ends of the MC1C DMC-bus, positions R00 and R09 at the back of the cartridge. Update the interchangeability of MC1C to D. Cover the old code from the interchangeability label by using a drawing pen or replace a label when only one interchangeability code is printed on the label.

Switch the BCSU cartridge power on from the PSC3 power supply.

Change the BCSU state to TE-EX .

```
ZUSC:BCSU,<index>:SE,;  
ZUSC:BCSU,<index>:TE,;
```

Run diagnostics.

```
ZUDU:BCSU,<index>;
```

If diagnostics fail, follow the steps described in **Diagnosis Reports (2.5 Alarm Reference Manual)** manual. Once the diagnostics have been passed, change the BCSU state to SP-EX:

```
ZUSC:BCSU,<index>:SP,;
```

Change the working BCSU to SP-EX :

```
ZUSC:BCSU,<index>:SP,;
```

Repeat these steps for all BCSUs.

6.4 OMU upgrade with WDDC Cartridge

The execution time of OMU upgrade step is one hour. OMU High Capacity hardware is installed when OMU is in SE-NH state.

6.4.1 Disable the measurements and observations

The measurements must be disabled during the OMU upgrade. Also, Q3-links must be blocked during the OMU upgrade. This needs to be done because disk updatings are prevented when OMU is not in use because of the hardware changes. It is impossible to copy measurement files to disks when the OMU is not working.

Subscriber traces must be stopped from the MSC. Note that if a traced subscriber has a call on, the trace does not stop until the call is released. Therefore it is recommended to wait for couple of minutes (that the call is released). If subscriber trace is active there is an open observation file in a BSC.

All measurements should be stopped from the NMS/2000 WS. The command to check measurement states from BSC is:

```
ZTPI ;
```

Make sure that all the measurements with the administrative state 'UNLOCKED' are turned to 'LOCKED'. Disable measurements using NMS applications until all measurements and observations are inactivate.

6.4.2 Check measurements

Check that all measurements and observations have been transferred:

```
ZIFI:OMU,MEASUR:S;  
ZIFI:OMU,OBSERV:S;
```

If there are files in FULL state, wait for 2 minutes and check again. Files can be put into transferred state with MML command:

```
ZIFS:OMU,MEASUR:1&&<file_cnt>:T;  
ZIFS:OMU,OBSERV:1&&<file_cnt>:T;
```

6.4.3 Copying databases and files to disk

It is recommended that the database be copied from memory to disks before the HW changes. This is to make sure that the latest information is updated.

```
ZDBC:BSDATA,0;  
ZDBC:OEDATA,0;  
ZDBC:EQUIPM,0;
```

Copy the files:

```
ZDFC:MCMU,<woex_mcmu>;
ZDFC:OMU;
```

6.4.4 Old OMU HW

Check the OMU hardware with command:

```
ZWTI:P:OMU;
```

Delete the old CPU plug-in unit from the equipment database (CP4HX or CP4HL):

```
ZWTQ:OMU:<CPU_type>,0;
```

Disconnect the function of AS7-US and delete it from the equipment database.

```
ZWUD:OMU:AS7_U,1;
ZWTQ:OMU:AS7_U,1;
```

CP6LX/CP6MX has an onboard SCSI-adapter which makes the SCSI-adapter in OMU (SCSIF) obsolete. Delete the SCSIF board from the equipment database (see picture 6).

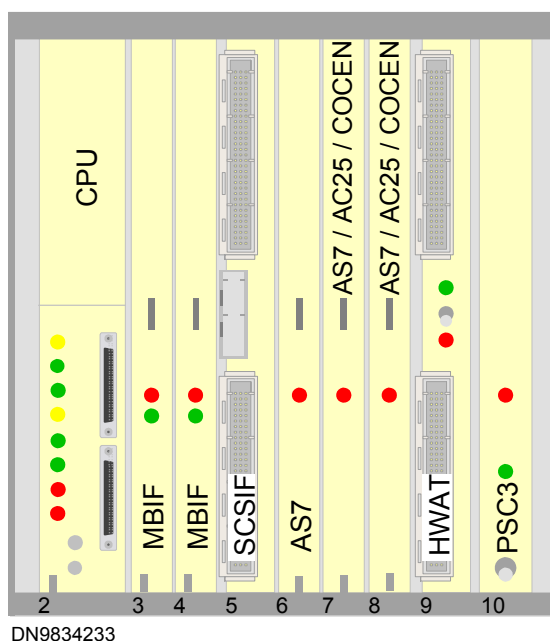

Picture 6. Implementation of OMU in BSC2A.

```
ZWTQ:OMU:SCSIF,0;
```

Delete X.25 plug-in units from the equipment database (when X.25 is used).

First, disconnect the function of AS7-US if digital X.25 is used:

```
ZWUD:OMU:AS7_U,2;  
ZWTQ:OMU:AS7_U,2;
```

If analog X.25 is used:

```
ZWTQ:OMU:AC25_S,2;
```

If redundant digital X.25 is used:

```
ZWUD:OMU:AS7_U,3;  
ZWTQ:OMU:AS7_U,3;
```

If analog X.25 is used:

```
ZWTQ:OMU:AC25_S,3;
```

Create the AS7-VA or AS7-US for digital X.25:

```
ZWTP:OMU:<AS7_TYPE>,2,7::X25,4,1,TSL,0;  
ZWUC:OMU:<AS7_TYPE>,2;
```

Or, when analog X.25 is used (base address is set to default):

```
ZWTP:OMU:AC25_S,2,7;
```

If redundant X.25 is used, create digital X.25:

```
ZWTP:OMU:<AS7_TYPE>,3,8::X25,4,1,TSL,16;  
ZWUC:OMU:<AS7_TYPE>,3;
```

Or, when analog X.25 is used:

```
ZWTP:OMU:AC25_S,3,8;
```

CP6LX/CP6MX has an Ethernet interface and, therefore, the existing Ethernet interface plug-in unit COCEN is not equipped with CP6LX/CP6MX. Delete the COCEN PIUs with the following commands.

COCEN plug-in unit in track 7:

```
ZWTQ:OMU:COCEN,2;
```

COCEN plug-in unit in track 8:

```
ZWTQ:OMU:COCEN,3;
```

Delete HWAT.

```
ZWTQ:OMU:HWAT,4;
```

6.4.5 Creation of new HW

Alarm inputs for BSC2A WDDC0 and WDDC1 cartridges are created with:

```
ZWTC:WDDC,1A058-13, : P1=1A058-13,P2=1A058-13,AL=1A120-37-04S3, ;
ZWTC:WDDC,1A058-01, : P1=1A058-01,P2=1A058-01,AL=1A120-37-02S5, ;
```

The following picture shows the HW implementation in OMU.

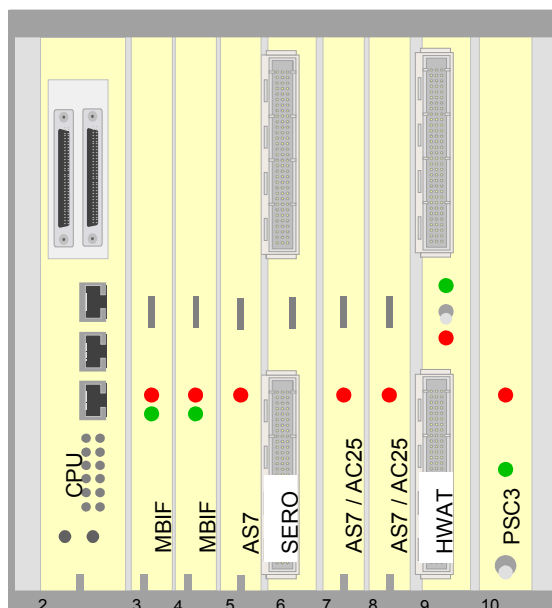

Picture 7. Implementation of OMU in BSC2i.

Create a CPU plug-in unit :

```
ZWTP:OMU:CP6LX/CP6MX,0,2; or ZWTP:OMU:CP6MX,0,2;
```

CP6LX/CP6MX does not provide an MML-interface. Therefore, the OMU is equipped with a SERO-T plug-in unit.

```
ZWTP:OMU:SERO_T,0,6;
```

Recreate HWAT (to change the HWAT address):

```
ZWTP:OMU:HWAT,4,9;
```

Create the AS7-VA/AS7-X plug-in unit and connect the function of it.

```
ZWTP:OMU:AS7_VA,0,5::LAPD,4,2,TSL,0&&31:LAPD,4,3,TSL,0&&31::;
ZWUC:OMU:AS7_VA,0::;
```

Or:

```
ZWTP:OMU:AS7_X,0,5::LAPD,4,2,TSL,0&&31:LAPD,4,3,TSL,0&&31:;
ZWUC:OMU:AS7_X,0:;
```

6.4.6 COCEN PIU AND NMS/2000 LAN connection with CP6LX/CP6MX

The following steps are executed only if a LAN type Q3 connection with COCEN plug-in unit is used.

The COCEN plug-in unit is not supported in the OMU hardware configuration when the CP6LX/CP6MX CPU is implemented. CP6LX/CP6MX has a built-in LAN interface for an NMS/2000 link. Broadband OSI CLNS Linkage has to be modified to support CP6LX/CP6MX for LAN connections.

Print out the existing LAN linkage with command:

```
ZQLI:::BRO;
```

Example printout:

```
LOADING PROGRAM VERSION 2.3-0
DX 200   BSC66                               1999-04-06  13:06:12
INTERROGATING LINKAGE DATA
NODE IN ES ROLE
LINKAGE TYPE ROLE UNIT   LOG UNIT TERM SNPA ADDRESS   PVC  Prio STATE
-----
   1   BRO   ES  OMU   4002H   3     -                -   -   LOC-DIS
COMMAND EXECUTED
```

Block LAN connection to NMS with command:

```
ZQLG:<link number>::LOC;
```

Remember that after the Q3 link has been blocked, no alarms will be forwarded to the NMS. The BSC alarms should, therefore, be followed to keep track of any unexpected phenomenon.

Delete the LAN linkage with command:

```
ZQLD:<linkage>;
```

6.4.7 Copy EQUIPM database to disk

```
ZDBC:EQUIPM,0;
```

Check that the database states are normal and that they are consistent with both Winchester disks. Check these with commands:

```
ZDBS:BSDATA,0;  
ZDBS:OEDATA,0;  
ZDBS:EQUIPM,0;  
ZDBD:OMU;
```

Make sure that there are no disk updatings in queue.

```
ZDUQ;
```

The values of SIMQUE and SEQQUE must be zero (0).

6.4.8 Prevent database and disk updates

```
ZDBP:BSDATA,0:DISK;  
ZDBP:OEDATA,0:DISK;  
ZDBP:EQUIPM,0:DISK;
```

```
ZDUP::NO;
```

6.4.9 OMU state change

Change OMU to state SE-NH.

```
ZUSC:OMU:TE;  
ZUSC:OMU:SE;  
ZUSC:OMU:SE;
```

6.4.10 Installation of new HW

Switch the OMU cartridge power off from the PSC3 power supply. Switch the WDDC0 and WDDC 1 cartridge power off from the PSC4 power supplies. Remove the following old hardware:

- CP4HX/CP4HL CPU from track 2
- SCSI-IF plug-in unit from track 5
- SCSI bus cables from OMU SCISIF to WDDC0
- AS7-US plug-in unit from track 6
- COCEN plug-in units from track 7/8
- SCSI bus cables between WDDC0 and WDDC1

BSC2I is equipped with WDDC0 and WDDC1 cartridges, verify that the interchangeability code of these cartridges is version B. If the interchangeability code is version A, retrofit both WDDC0 and WDDC1 to version B, before continuing:

WDDC retrofit from interchangeability code A to B (skip if WDDC code is B):

On the backside of the WDDC mother board, the cabling frames in positions R00 and S03 are changed to frames which support connectors in circular SCSI cables (same type of frame which is in position S00 and S02). Lock Flats, which lock SCSI cables to the WDDC Connectors, are also removed from the connectors in positions R00 and S03. (Existing old frame and lock flat prevent the installation of a new SCSI bus cable or terminator. Therefore, a retrofit is needed). Remove the old plastic frames with side-cutting pliers or pointed pliers. Usually a frame will fall to pieces when it is removed. Install a new plastic frame and check that it is properly fixed.

Together with the connector frame change, change to a wider model of earthing strip to improve the earthing of the cartridge. See appendix 8 and picture Mounting of Cartridge. The grounding part is number 6 in the picture. Special care must be taken to avoid dropping screws into the inside of the cabinet. Place a paper or plastic board under the WDDC cartridge when replacing the earthing strip.

Update the interchangeability of WDDC to B. Cover the old code from the interchangeability label by using a drawing pen.

Check which type of SCSI BUS terminators are in use. In BSC2A, terminators are located at the back of the WDDC1 cartridge in positions **R00** and **S03**. If SCSI bus terminators are of type **SCSIT C23580**, they must be replaced with **SCSIT-S C23580**. This is done to avoid SCSI bus disturbances when CP6LX/CP6MX is used as an SCSI interface.

Set the AS7-VA/AS7-X strappings according to *appendix 5* and *6* and install an AS7-VA/AS7-X plug-in unit to track 5 in OMU. If Digital X.25 is used, install AS7-VA,AS7-X or AS7-US to track 7. Also, if redundant X.25 is used then install AS7-VA,AS7-X or AS7-US to track 8.

Set the SERO-T strappings according to *appendix 9* and install a SERO-T plug-in unit to track 6 in OMU.

Install the DMCT2-S terminator for the DMC bus. The termination block is equipped to both ends of the MC1C DMC-bus, positions R00 and R09 at the back of the cartridge. Update the interchangeability of OMU MC1C to D. Cover the old code from the interchangeability label by using a drawing pen or replace a label when only one interchangeability code is printed on the label.

Install a new cross-connection brick (**PCMCO05 C72504**) to the back of OMU MC1C. The cross-connection brick is installed to position Y05 at the back of the OMU MC1C cartridge. PCM 1, which has been used for Q1 and LapD in slot 6, is re-routed to slots 7 and 8 for X.25. PCMs 2 and 3 (previously used for X.25) will be re-routed to slot 5.

Remove the old VDU/LPT connector panel and install the eight-slot connector panel **CBD8 C72502**. Install VDU/LPT cables to the eight-slot connector panel before installing the panel to the rack. A new eight-slot connector panel is needed for full utilization of the interfaces provided by SERO-T. The software supports four MML- and two LPT-interfaces. Special care must be taken to avoid dropping screws into the inside of the cabinet. Place a paper or plastic board under the Bracket when replacing the connector panel:

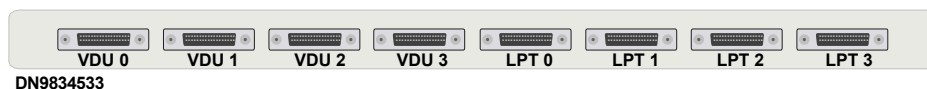

Picture 8. CBD8 C72502 Connector Bracket for D connectors.

Install VDU/LPT cables according to the cable list:

BSC2A LPT/VDU Cable list:

When upgrading from BSC2 to BSC2i remove cable 1.122

1.122	BCBE	OMU	058.27F 05X1	BCBE	CBD2	116.46B D25	CLQS019	VDU
-------	------	-----	--------------	------	------	-------------	---------	-----

When upgrading from BSC2A to BSC2i Install cables:

No.	Rack	FE	Connector	Rack	FE	Connector	Type	Use
1.90	BCBE	OMU	058.27F 06R7	BCBE	CBD8	116.28B LPT0 116.34B LPT1	CLQS012	LPT
1.91	BCBE	OMU	058.27F 06R5	BCBE	CBD8	116.04B VDU0 116.10B VDU1	CLQS012	VDU
1.92	BCBE	OMU	058.27F 06R3	BCBE	CBD8	116.40B LPT2 116.46B LPT3	CLQS012	LPT
1.93	BCBE	OMU	058.27F 06R1	BCBE	CBD8	116.16B VDU2 116.22B VDU3	CLQS012	VDU

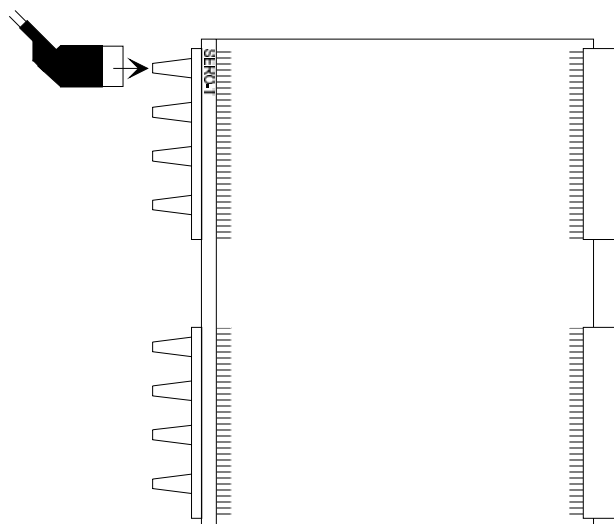

6.4.11 CP6LX/CP6MX installation with WDDC SCSI cabling

Set the CP6LX/CP6MX strappings according to the documentation in appendix 3 and 4. Install new SCSI cables **CJF 007 C83179** to the CP6LX/CP6MX. Install 16 bit SCSI bus terminators **SCSIT-V C72180** to the top of the SCSI cable connectors in CP6LX/CP6MX. Install the CP6LX/CP6MX CPU plug-in unit with SCSI cables to the OMU. If the BSC has been equipped with a COCEN card for an NMS connection, connect the LAN cable to the CP6LX/CP6MX's LAN connector.

When the SCSI cable CJF 007 is installed to CP6LX/CP6MX, take special care that connectors and SCSIT-V terminators are installed firmly to the CPU. Loose connectors or bent connector pins prevent CP6LX/CP6MX startup, and further, this leads to a situation in which OMU will not restart. CP6LX/CP6MX's new SCSI-bus terminators are used on the CP6LX/CP6MX end of the SCSI-cable:

Type	Name	ID number	Amount
SCSI-cable	CJF007	C83179	2
16-bit terminator	SCSIT-V	C72180	2

Install the new mass memory cartridge alarm cables **CFT** from WDDCs to the CLOC cartridges (alarm groups 11 and 12). Also install **CJF** SCSI bus cables to the back of the WDDC0 cartridge. Use locking latches to ensure a firm connector installation to the connector frame. Install new **CFHA** SCSI cable(s) between WDDC0 and WDDC1 (to the top of the **CFT** alarm cables). See the cable lists on the next page for the right positions.

Set the power alarm control of the WDDC1 cartridge. The alarm control of the WDDC1 power supply is set as follows:

WDDC	Power Supply	Jumper Block	Jumper Set
0	PS0	W2	0
0	PS1	W4	4
1	PS0	W2	0
1	PS1	W4	4

Check that cables and terminators are installed according to the following cable lists.

BSC2A, Cable list:

When upgrading from BSC2A to BSC2i Install cables and terminators:

No.	Rack	FE	Connector	Rack	FE	Connector	Type	Use
1.94	BCBE	OMU	058.27F 02J6A	BCBE	WDDC 0	058.13B 00R1	CJF007	SCSI 0
1.95	BCBE	OMU	058.27F 02J6B	BCBE	WDDC 0	058.13B 03S1	CJF007	SCSI 1
1.96	BCBE	WDDC 0	058.13B 00S1	BCBE	WDDC 1	058.01B 00S1	CFHA002	SCSI 0
1.97	BCBE	WDDC 0	058.13B 02S1	BCBE	WDDC 1	058.01B 02S1	CFHA002	SCSI 1
1.98	BCBE	CLOC	120.37B 04S3	BCBE	WDDC 0	058.13B 00S1 058.13B 02S1	CFT015	AL (AG11)
1.99	BCBE	CLOC	120.37B 02S5	BCBE	WDDC 1	058.01B 00S1 058.01B 02S1	CFT015	AL (AG12)
SCSI Terminators: When upgrading from BSC2 to BSC2i check and add the terminators:								
	BCBE	OMU	058.27F 02J6A				SCSIT-V	SCSI 0
	BCBE	OMU	058.27F 02J6B				SCSIT-V	SCSI 1
	BCBE	WDDC 1	058.01B 00R1				SCSIT-S	SCSI 0
	BCBE	WDDC 1	058.01B 03S1				SCSIT-S	SCSI 1

Switch the WDDC0 and WDDC 1 cartridge power on from the PSC4 power supplies. Switch the OMU cartridge power on from the PSC3 power supply. MML session is available after OMU CPU has restarted to SE-NH state. Restart can be monitored from the service terminal connector of CP6LX/CP6MX.

6.4.12 Running diagnostics

Change OMU to state TE-EX and run diagnostics.

```
ZUSC:OMU:SE;
ZUSC:OMU:TE;

ZUDU:OMU:;
```

If diagnostics fail, follow the steps described in the **Diagnosis Reports (2.5 Alarm Reference Manual)** manual. Once the diagnostics have been passed, change the OMU state to WO-EX.

```
ZUSC:OMU:WO;
```

Change the WDU to TE-ID state and run diagnostics:

```
ZISC: ,OMU:WDU ,<no>:WO-ID;
ZISC: ,OMU:WDU ,<no>:TE-ID;

ZUDD:OMU:WDU ,<no>:;
```

Check the results of WDU diagnostics from the printer. After successful WDU diagnostics, change the WDU to WO-BU state:

```
ZISC: ,OMU:WDU ,<no>:WO-ID;
ZISC: ,OMU:WDU ,<no>:WO-BU;
```

Execute diagnostics for both WDUs one by one.

6.4.13 Resume Database and Disk updates

```
ZDUR;
ZDBR:BSDATA,0:DISK;
ZDBR:OEDATA,0:DISK;
ZDBR:EQUIPM,0:DISK;
```

6.4.14 LAN NMS/2000 links

The following steps are executed only if a LAN type NMS connection with COCEN plug-in unit is used.

The COCEN plug-in unit is not supported in the OMU hardware configuration when the CP6LX/CP6MX CPU is implemented. CP6LX/CP6MX has a built-in LAN interface for an NMS/2000 link. Broadband OSI CLNS Linkage has to be modified to support CP6LX/CP6MX for LAN connections.

Create new OSI linkage for CP6LX/CP6MX with command:

```
ZQLL::ES:OMU:0::;
```

Example printout:

```
DX 200      BSC62                      1999-04-06  13:14:38

CREATING BROADCAST LINKAGE

NODE IN ES ROLE

LINKAGE  ROLE  UNIT      LOG      PARAMETER
UNIT    TERM  SET NAME
-----  -
      0    ES  OMU      4002H    0  BRODFSET

COMMAND EXECUTED
```

Print out the new CP6LX/CP6MX LAN linkage with command:

```
ZQLI:::BRO;
```

Example print out:

```
LOADING PROGRAM VERSION 2.3-0

DX 200      BSC62                      1999-04-06  13:14:43

INTERROGATING LINKAGE DATA

NODE IN ES ROLE

LINKAGE  TYPE  ROLE  UNIT      LOG  UNIT  TERM  SNPA  ADDRESS      PVC  PRIO  STATE
-----  -
      1    BRO   ES   OMU      4002H    0    -    -    -    -    -    LOC-DIS

COMMAND EXECUTED
```

Unlock the LAN connections to the NMS with command:

```
ZQLG:<link_number>::UNL;
```

6.4.15 Start Measurements

Start the GSM measurements which were active before the OMU HW upgrade from the NMS/2000.

7 ET HW upgrade

Two new optional ET5C cartridges can be installed to the bottom of the BSC extension rack. The maximum number of external ET_PCM is then increased from 80 to 112 PCMs.

However, the EGPRS feature introduced in S10.5 software brings additional two optional ET5C cartridges. They can be installed to the bottom of the BSC2A extension rack. The maximum number of external ET_PCM is then further increased from 112 to 144 PCMs. See Picture 9. S10.5 BSC2i with EDGE hardware. Instructions for ET5C-7 and ET5C-8 cartridge installation are found in S10.5 document: BSC S10.5 GPRS/EDGE Hardware Implementation Procedure.

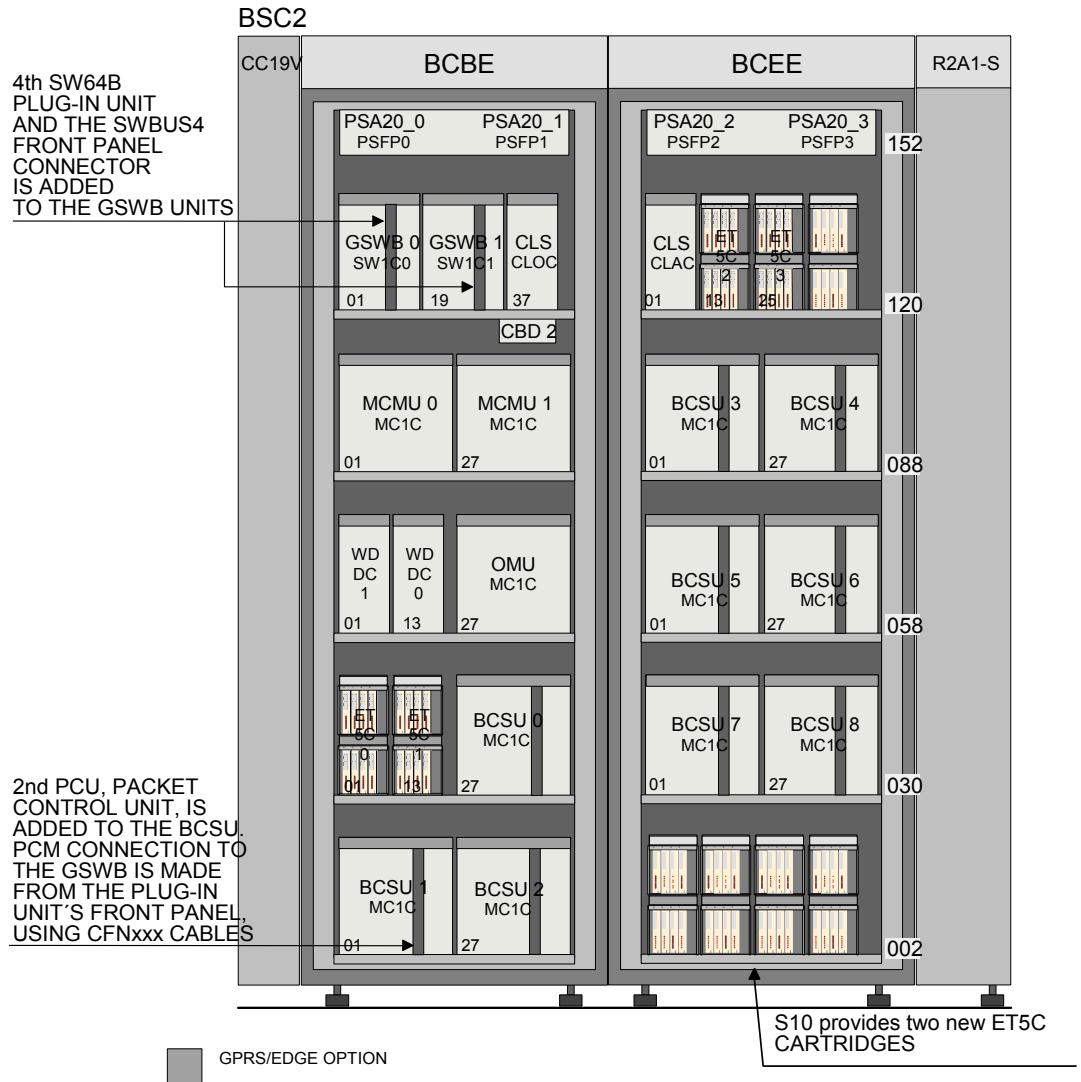

Picture 9. S10.5 BSC2i with EDGE hardware.

The bottom shelf of the BCEE-rack (CS6A-T C23697) is not equipped in BSC2As already in the field. However, this shelf is standard configuration in BSC2i. When upgrading to BSC2I, the bottom shelf is needed for the extra ET5C cartridges. Install the shelf to the rack.

Install ET5C cartridges to the bottom of the BSC2A's extension rack (see cartridge picture in appendix for details). Connect the power, PCM, and alarm cables according to the cable list. Set the ET plug-in unit strappings and install ET plug-in units to the ET5 cartridge. Set ET5C cartridge strappings according to appendix 10.

When installing the cabling, avoid sharp bends and make sure that the cables are not pulled too tight. The BSC may be carrying traffic during the upgrade and therefore special care must be taken to avoid disconnecting other cables or connectors.

If BSC2A is not equipped with an ET5C-4 cartridge (part of the large capacity BSC feature), instructions for installation and creation of ET5C-4 ETs are found in *S10.5 Large Capacity feature implementation procedure*.

ET5C-5 and ET5C-6 Cable lists:

No.	Rack	FE	Connector	Rack	FE	Connector	Type	Use
2.70	BCEE	PSFP 2	148.03B P7	BCEE	ET5C 5	002.01B_PL1	CVKT022	POWER
2.71	BCEE	PSFP 3	148.27B P7	BCEE	ET5C 5	002.01B_PL2	CVKT025	POWER
2.72	BCBE	SW1C 0	120.01B 03S7	BCEE	ET5C 5	002.01B 00V1	CEB032	PCM
2.73	BCBE	SW1C 0	120.01B 04R1	BCEE	ET5C 5	002.01B 00V3	CEB033	PCM
2.74	BCBE	SW1C 1	120.19B 03S7	BCEE	ET5C 5	002.01B 00V5	CEB031	PCM
2.75	BCBE	SW1C 1	120.19B 04R1	BCEE	ET5C 5	002.01B 00V7	CEB032	PCM
2.76	BCEE	CLAC	120.01B 04R5	BCEE	ET5C 5	002.01B 04S1	CFB025	AL/CLK 5)
2.77	BCEE	PSFP 2	148.03B P8	BCEE	ET5C 6	002.13B_PL1	CVKT022	POWER
2.78	BCEE	PSFP 3	148.27B P8	BCEE	ET5C 6	002.13B_PL2	CVKT025	POWER
2.79	BCBE	SW1C 0	120.01B 04R3	BCEE	ET5C 6	002.13B 00V1	CEB033	PCM
2.80	BCBE	SW1C 0	120.01B 04R5	BCEE	ET5C 6	002.13B 00V3	CEB033	PCM
2.81	BCBE	SW1C 1	120.19B 04R3	BCEE	ET5C 6	002.13B 00V5	CEB031	PCM
2.82	BCBE	SW1C 1	120.19B 04R5	BCEE	ET5C 6	002.13B 00V7	CEB031	PCM
2.83	BCEE	CLAC	120.01B 03R7	BCEE	ET5C 6	002.13B 04S1	CFB024	AL/CLK 6)

Create hardware for ET5Cs:

```
//*****
// DX 200 BSC2i ***** ET5C-5 *****
//*****
// <ET_TYPE> is ET2A
```

```
ZWTC:ET5C,1B002-01:AL=01B120-01-5;
ZWTU:ET,120:1B002-01;
ZWTU:ET,121:1B002-01;
ZWTU:ET,122:1B002-01;
ZWTU:ET,123:1B002-01;
ZWTU:ET,124:1B002-01;
ZWTU:ET,125:1B002-01;
ZWTU:ET,126:1B002-01;
ZWTU:ET,127:1B002-01;
ZWTU:ET,128:1B002-01;
ZWTU:ET,129:1B002-01;
ZWTU:ET,130:1B002-01;
ZWTU:ET,131:1B002-01;
ZWTU:ET,132:1B002-01;
ZWTU:ET,133:1B002-01;
ZWTU:ET,134:1B002-01;
ZWTU:ET,135:1B002-01;

ZWTP:ET,120:<ET_TYPE>,0,0::ETT00,4,120,TSL,0;
ZWTP:ET,121:<ET_TYPE>,0,0::ETT00,4,121,TSL,0;
ZWTP:ET,122:<ET_TYPE>,0,1::ETT00,4,122,TSL,0;
```

```
ZWTP:ET,123:<ET_TYPE>,0,1::ETT00,4,123,TSL,0;
ZWTP:ET,124:<ET_TYPE>,0,2::ETT00,4,124,TSL,0;
ZWTP:ET,125:<ET_TYPE>,0,2::ETT00,4,125,TSL,0;
ZWTP:ET,126:<ET_TYPE>,0,3::ETT00,4,126,TSL,0;
ZWTP:ET,127:<ET_TYPE>,0,3::ETT00,4,127,TSL,0;
ZWTP:ET,128:<ET_TYPE>,0,4::ETT00,4,128,TSL,0;
ZWTP:ET,129:<ET_TYPE>,0,4::ETT00,4,129,TSL,0;
ZWTP:ET,130:<ET_TYPE>,0,5::ETT00,4,130,TSL,0;
ZWTP:ET,131:<ET_TYPE>,0,5::ETT00,4,131,TSL,0;
ZWTP:ET,132:<ET_TYPE>,0,6::ETT00,4,132,TSL,0;
ZWTP:ET,133:<ET_TYPE>,0,6::ETT00,4,133,TSL,0;
ZWTP:ET,134:<ET_TYPE>,0,7::ETT00,4,134,TSL,0;
ZWTP:ET,135:<ET_TYPE>,0,7::ETT00,4,135,TSL,0;
```

```
//*****
//                               ***** ET5C-6 *****
//*****
```

In Next step ET5C-6 cassette is created. Check the hardware and PCM cabeling of ET5C-6 cartridge.

```
ZWTC:ET5C,1B002-13:AL=01B120-01-6;
ZWTU:ET,136:1B002-13;
ZWTU:ET,137:1B002-13;
ZWTU:ET,138:1B002-13;
ZWTU:ET,139:1B002-13;
ZWTU:ET,140:1B002-13;
ZWTU:ET,141:1B002-13;
ZWTU:ET,142:1B002-13;
ZWTU:ET,143:1B002-13;
ZWTU:ET,144:1B002-13;
ZWTU:ET,145:1B002-13;
ZWTU:ET,146:1B002-13;
ZWTU:ET,147:1B002-13;
ZWTU:ET,148:1B002-13;
ZWTU:ET,149:1B002-13;
ZWTU:ET,150:1B002-13;
ZWTU:ET,151:1B002-13;
```

```
ZWTP:ET,136:<ET_TYPE>,0,0::ETT00,4,136,TSL,0;
ZWTP:ET,137:<ET_TYPE>,0,0::ETT00,4,137,TSL,0;
ZWTP:ET,138:<ET_TYPE>,0,1::ETT00,4,138,TSL,0;
ZWTP:ET,139:<ET_TYPE>,0,1::ETT00,4,139,TSL,0;
ZWTP:ET,140:<ET_TYPE>,0,2::ETT00,4,140,TSL,0;
ZWTP:ET,141:<ET_TYPE>,0,2::ETT00,4,141,TSL,0;
ZWTP:ET,142:<ET_TYPE>,0,3::ETT00,4,142,TSL,0;
ZWTP:ET,143:<ET_TYPE>,0,3::ETT00,4,143,TSL,0;
ZWTP:ET,144:<ET_TYPE>,0,4::ETT00,4,144,TSL,0;
ZWTP:ET,145:<ET_TYPE>,0,4::ETT00,4,145,TSL,0;
ZWTP:ET,146:<ET_TYPE>,0,5::ETT00,4,146,TSL,0;
ZWTP:ET,147:<ET_TYPE>,0,5::ETT00,4,147,TSL,0;
ZWTP:ET,148:<ET_TYPE>,0,6::ETT00,4,148,TSL,0;
ZWTP:ET,149:<ET_TYPE>,0,6::ETT00,4,149,TSL,0;
ZWTP:ET,150:<ET_TYPE>,0,7::ETT00,4,150,TSL,0;
ZWTP:ET,151:<ET_TYPE>,0,7::ETT00,4,151,TSL,0;
```

8 Completion of the Upgrade

8.1 Implementation of the new feature

Instructions are given in the S10.5 Feature Installation Manual: *Installation of Optional Features for BSC SW S10.5*. This document is included in the S10.5 Software Release Binders.

8.2 PSFP and Cartridge Marking Labels

Each BSC cartridge is provided with a marking label, which indicates e.g. the cartridge name, the PCM interface number, functional unit number or plug-in unit names, depending on the cartridge and its function. All marking labels, except for the ET1TC and ET5C cartridge labels, are filled in at the factory.

Due to the multiple plug-in unit configuration and allocation options offered, the labels for the ET1TC and ET5C cartridges have been left partially blank. The only details shown are the name of the cartridge and the positions of the plug-in units. The boxes left blank are filled in at the site, in accordance with the equipment configuration installed into each cartridge.

Attach the new cartridge marking labels to the BSC racks. The labels are delivered as a set in a separate bag. The use of the circuit breakers and fuses are indicated by the labels. Mark new cartridges on to the fuse labels or attach a new PSFP label to the rack.

8.3 Alternative VDU and LPT Settings

The SERO_T plug-in unit's serial port interfaces are numbered in the following way:

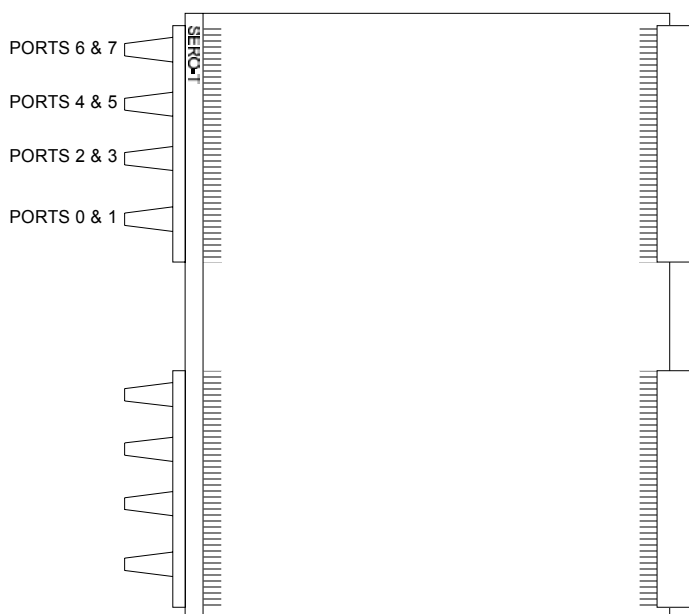

The serial port's VDU and LPT configuration can be printed out with the MML-command ZITI. Output can be, for example:

```
ZITI;

I/O          PIU          PORT TERMINAL BAUD DATA STOP PARITY PAGE    LINE
COMMON
DEVICE                               TYPE      RATE BITS BITS          LENGTH LENGTH
TIMER WITH

LPT-00  SERO -00 00  DUMMY    9600 7   2   EVEN   65    80
LPT-01  SERO -00 01  DUMMY    9600 7   2   EVEN   65    80
VDU-00  SERO -00 02  VDU220  9600 7   2   EVEN   23    80
VDU-01  SERO -00 03  VDU220  9600 7   2   EVEN   23    80
VDU-02  SERO -00 06  VDU220  9600 7   2   EVEN   23    80
VDU-03  SERO -00 07  VDU220  9600 7   2   EVEN   23    80
```

If another port configuration is needed, use ZITF and ZITM commands to reconfigure the ports.

8.4 TCP/IP Settings for LAN connection

LAN connections can be created to the BSC2i. The following example shows the MML commands needed to set up a CP6LX/CP6MX Telnet connection. Creation of the Ethernet interface to the OMU, eg. with address 131.228.47.123 with netmask length eg. 16:

```
ZQRC:OMU:ETH,0:131.228.47.123,16;
```

Change the state of the network interface to UP:

```
ZQRG:OMU:ETH,0:UP;
```

Change the state of the Telnet application to UP:

```
ZQJG:TELNETTCP:OMU:UP;
```

The LAN cable with the RJ45 connector can be installed directly to the CP6LX/CP6MX CPU's LAN interface.

9 Troubleshooting

BSC limits the amount of available TRX capacity according to the HW configuration. In case of HW configuration, the slowest speed CPU in a BSC limits the amount of available TRXs. The amount of TRXs available for the current configuration can be printed out with command:

```
ZEEI : :BCSU ;
```

MC1C Interchangeability code D is compatible with BSC2A hardware. It is not needed to return MC1C interchangeability code to B (ie. Unplug DMCT terminators) if some computer unit's HW is returned to BSC2A level.

9.1 MB- Messagebus Troubleshooting

Problems met in MBIF-UA upgrade are in most cases caused by the faulty piece of MBIF-UA hardware. And they are found automatically during the messagebus upgrade. SYSB diagnostics can be executed to check the Messagebus interface in particular computer unit. If MB problems are met after the upgrade, the faulty MB should be set to Test state, and use SYSB diagnostics to investigate the units. Monitor also for possible disturbance number 1016- "MB INTERFACE FAILURE" in alarm history. This disturbance directly discloses the Faulty MB and unit where the faulty plug-in unit is located.

CP6LX CPU does not support MBIF-T plug-in units. CP4HX/ CP4HL CPU supports both MBIF-T and MBIF-UA plug-in units. All message bus cards must be of the same type throughout the whole message bus. All of the MBIFs must be of the type MBIF-UA, when there is CP6LX/CP6MX installed in BSC HW.

9.2 – BCSU upgrade Troubleshooting

Problems met in BCSU upgrade are in most cases caused by the faulty piece of installed plug-in unit hardware. And they are found automatically during the upgrade. BCSU diagnostics can be executed to check the particular BCSU computer unit. If there appears problems in the startup phase of the unit, check also the DMCT2-S terminators at the back of the MC1C cartridge. Terminator may be faulty or it is not properly installed in it's place.

9.3 – MCMU upgrade Troubleshooting

Problems met in MCMU upgrade are in most cases caused by the faulty piece of installed plug-in unit hardware. And they are found automatically during the upgrade. BCSU diagnostics can be executed to check the particular BCSU computer unit. If there appears problems in the startup phase of the unit, check also the DMCT2-S terminators at the back of the MC1C cartridge. Terminator may be faulty or it is not properly installed in it's place.

9.4 – OMU upgrade Troubleshooting

OMU upgrade troubleshooting is more complicated compared to the other computer unit upgrades in the high capacity BSC upgrade. Main problem is that if the OMU unit does not start-up, there is no MML available for troubleshooting. This is because of the fact that SERO plug-in unit is located in the OMU, and thus it is not available if OMU is not working.

If the OMU does not start-up, does not load the software properly, or OMU stays in reset loop, then proceed according to following instructions:

1. Verify that OMU hardware was created properly. Check from HIT logfiles that HIT macro configured the OMU in a normal way. Check that all necessary commands were executed.
2. If the configuration is right, then the fault lies is hardware itself. Check all the installed OMU and IO-device hardware one by one. Use only tested spareparts to verify the operation. Replace all the plug-in units one by one until the faulty unit has been found. Usually loading problems are caused by the CPU or SCSI-bus problems. First replace CPU. Check SCSI-cables that they are properly installed and/or verify the operation with spareparts SCSI cables. Check also following I/O hardware (and verify the operation with spareparts):
 - FDU,0
 - CTU,0
 - SCSI terminators
 - WDU jumpers. Actual WDU jumpers are located in the bottom of the WDU.Unscrew the WDU from the Frame, jumpers are at the bottom side. Specially look at SCSI address settings.
 - DAT jumpers. Actual DAT jumpers are located in the bottom of the WDU.Unscrew the DAT from the Frame.
 - DMCT2-S terminators at the back of the MC1C cartridge

NOTE: OMU does not start-up with BSC2A level OMU hardware, if the high capacity configuration is found from the EQUIPM- database. This is because in BSC2A there is SCSI-IF plug-in unit installed to track 5, which is used for AS7-VA or AS7-X function in BSC2i. So, if the BSC is not starting with new hardware, neither it does not start-up with old hardware if there is new configuration defined in the BSC files. Therefore the only way to troubleshoot is to find out the faulty OMU / IO device -hardware unit in high capacity configuration. (Special methods are required to return the old HW-configuration in EQUIPM, in this case please contact the Nokia BSC Technical Support.)

APPENDICES

Appendix 1. Description of WDDC cartridge improvement

WDDC, Winchester Cartridge Interchangeability change **A ->B**

Note: BSC deliveries from the factory with the interchangeability B began in the week 44/97.

A change in the cabling method of the SCSI bus. When the old method of SCSI cabling (WDDC Interchangeability A) is used, an extra branch remains on the SCSI bus in the WDDC cartridge. The SCSI bus continues and the SCSI bus terminator is connected on top of the incoming bus cable. In the WDDC cartridge, the SCSI bus also branches to the motherboard of WDDC.

Changes to be made for BSC2 WDDC Interchangeability B:

On the WDDC mother board, on the backside of the board, the cabling frames in positions R00 and S03 are changed to frames which support connectors in circular type SCSI cables (same type of frame as in positions S00 and S02). Lock Flats which are locking SCSI cables to the WDDC Connectors are also removed from connectors in positions R00 and S03.

Cabling changes:

For BSC2A:

1.54	BCBE	WDDC 0	058.13B 00S1	BCBE	WDDC 1	058.01B 00S1	CFHS004	SCSI
1.55	BCBE	WDDC 0	058.13B 02S1	BCBE	WDDC 1	058.01B 02S1	CFHS004	SCSI
1.56	BCBE	OMU	058.27F 05R1	BCBE	WDDC 0	058.13B 00R1	CFH007	SCSI
1.57	BCBE	OMU	058.27F 05S1	BCBE	WDDC 0	058.13B 03S1	CFHS006	SCSI

SCSI Bus 0 **Cable 1.56** coming from OMU SCsIF PIU is connected to the position R00 in WDDC0 cartridge.

SCSI Bus 1 **Cable 1.57** coming from OMU SCsIF PIU is connected to the position S03 in WDDC0 cartridge.

The bus terminals SCsIT-S on top of the bus cables in WDDC1 are moved to positions S03 and R00.

Cabling for BSC2i:

1.94	BCBE	OMU	058.27F 02J6A	BCBE	WDDC 0	058.13B 00R1	CJF007	SCSI
1.95	BCBE	OMU	058.27F 02J6B	BCBE	WDDC 0	058.13B 03S1	CJF007	SCSI
1.96	BCBE	WDDC 0	058.13B 00S1	BCBE	WDDC 1	058.01B 00S1	CFHA002	SCSI
1.97	BCBE	WDDC 0	058.13B 02S1	BCBE	WDDC 1	058.01B 02S1	CFHA002	SCSI

At the same time, check the types of the SCSI BUS terminators. Terminators are located on the back of the WDDC1 cartridge in positions **R00** and **S03**. If SCSI bus terminators are of type **SCSIT C23580**, they must be replaced with **SCSIT-S C23580**.

Together with the connector frame change, change the earthing strip to a wider one to improve the earthing of the cartridge. See appendix 8 and picture *Mounting of Cartridge*. The grounding part is number 6 in picture.

After all the above mentioned work is done, update the interchangeability of the WDDC to B. Cover the old code from the interchangeability label using a drawing pen.

Appendix 2. MBIF-UA C 8887 Jumper Settings

Strappings of the plug-in unit MBIF-UA:

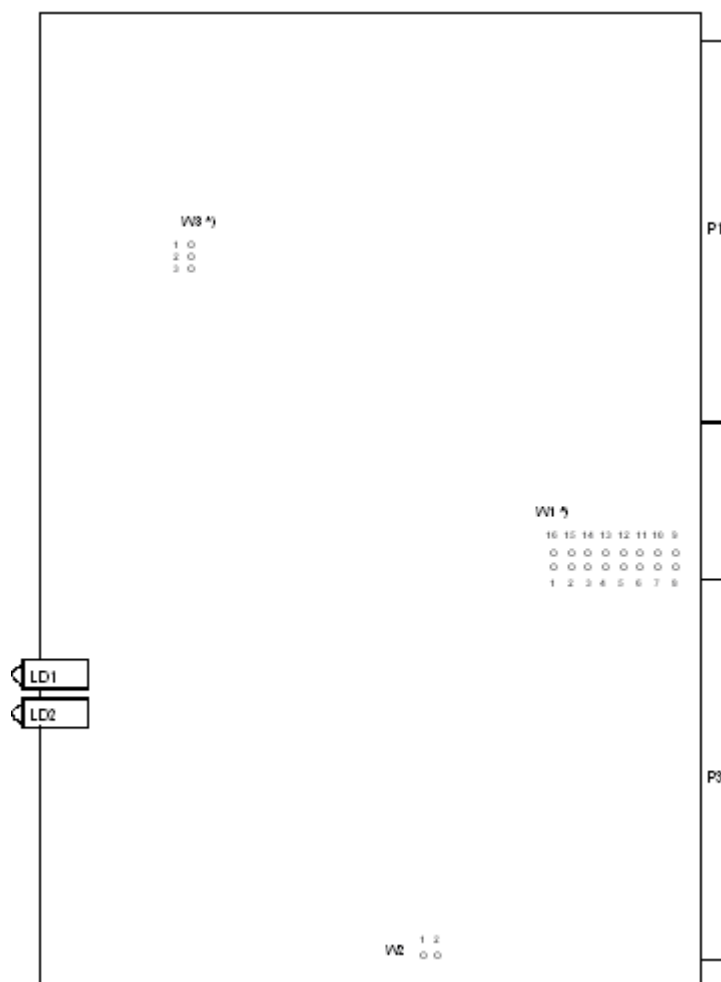

Standard settings:

Strapping Group	Connection	Note
W1	-	Wired addresses with 7 bits. Selection of frequencies with wirings.
W2	-	The MB is set to operate 16-bit mode.
W3	1-2	Reception moment 31 ns before the transmission cycle ends.

Appendix 3. CP6LX Jumper Settings

Jumpers of the central processor CP6LX:

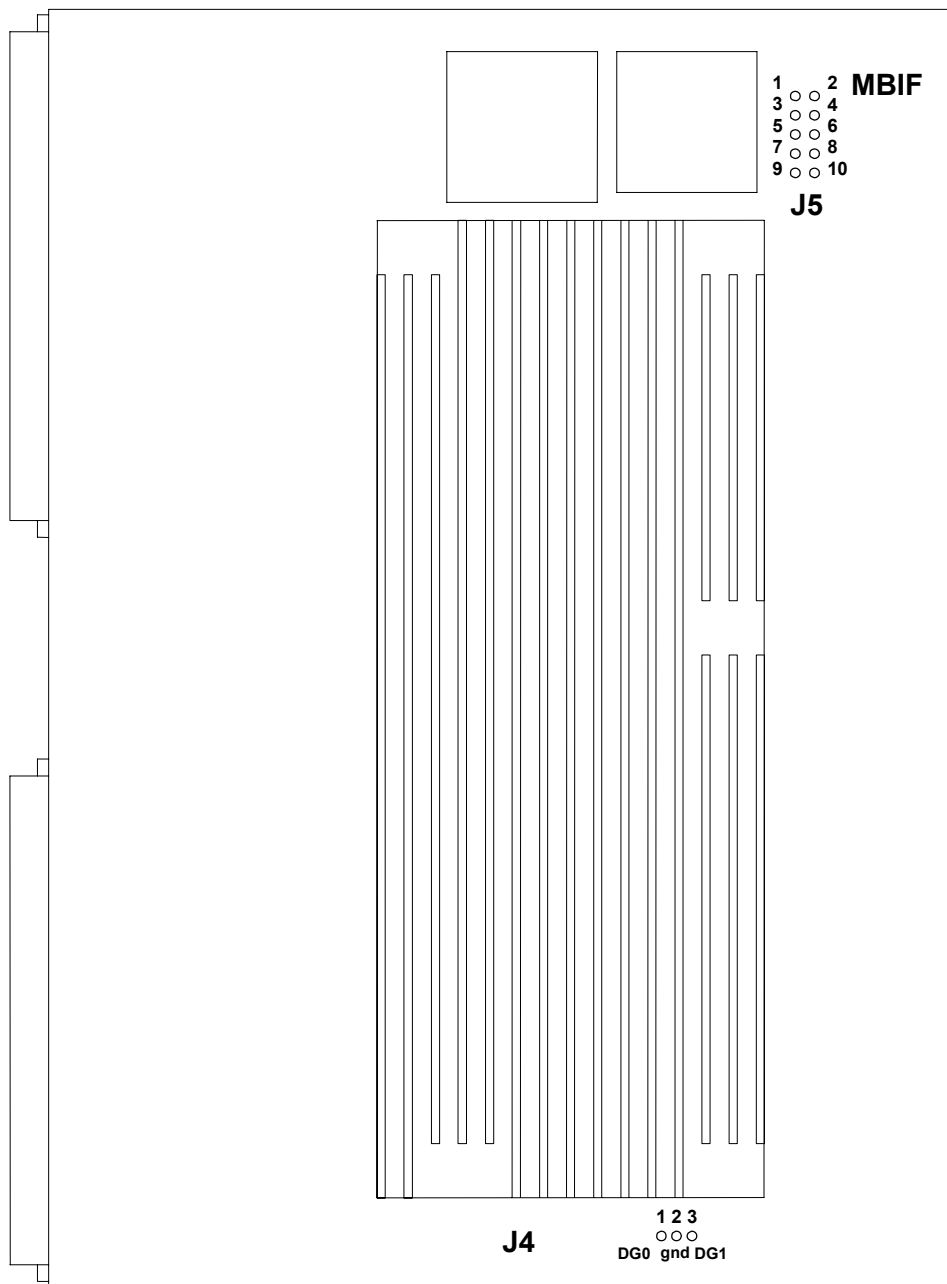

Alternative settings are presented in the tables below.

Jumper block J5 is used to set the MBIF usage and the interchangeability of the plug-in unit delivered. The jumpers drive a signal line to “0” when installed and result in the following functions.

MBIF setting (jumper group J5):

Connection	Jumper	Meaning	Note
J5: 1-2	On	MBIF in use	Default
	Off	MBIF not used	

Interchangeability code settings (jumper group J5):

Connection	Interchangeability code														R
	A	B	C	D	E	F	G	H	J	K	L	M	N	P	
J5: 3-4	X		X		X		X		X		X		X		X
5-6	X	X			X	X			X	X			X	X	
7-8	X	X	X	X					X	X	X	X			
9-10	X	X	X	X	X	X	X	X							

X = jumper connected, blank = jumper removed

Note that interchangeability codes I, O, and Q are not allowed.

DMC/BUS/SPEED setting (jumper group J4):

Jumper block J4 defines the DMC bus speed.

Connection	Jumper	Meaning	Note
J4: DG0 - GND	On	Subrack, slowest speed	Default
J4: GND - DG1	On	Optional timing (not implemented)	do not use
	None	Fastest speed	

Appendix 4. CP6MX DIP-switches

There are no jumpers in CP6MX. All the settings are made by using the microswitches in switch package SW1:

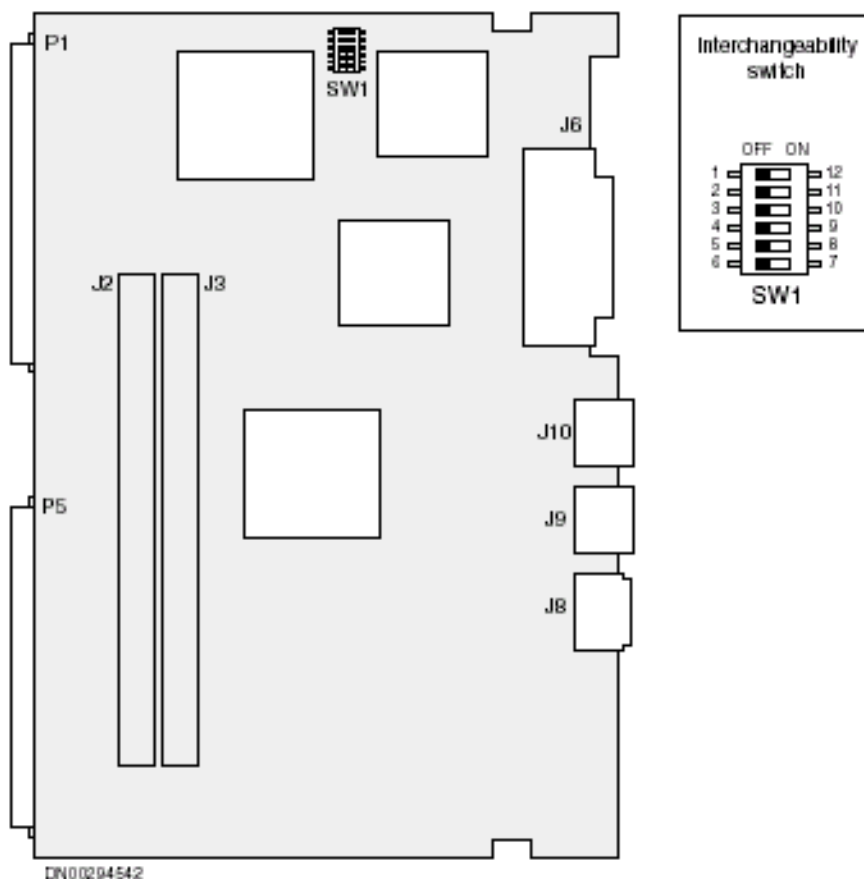

The Switch Block consists of a 6 position DIP switch. This switch contains the four Interchangeability code bits, the MBIF status, and the DMC bus speed setting. The interchangeability lines drive to “0” when the switches are OFF.

The MBIF status drives the signal to “0” when switch is OFF. The DMC bus speed drives digital input 1 of the DMCI0B. The slow speed corresponds to switch OFF. The fast speed corresponds to the switch ON.

SW1	Setting	Function
6-7	OFF	MBIF status; MBIF assembled. Default setting.
	ON	MBIF status; MBIF not assembled.
5-8	OFF	DMC bus speed; slow timing mode. Default setting.
	ON	DMC bus speed; fast timing mode.
4-9	See below	DMX Interchangeability code bit 0
3-10	See below	DMX Interchangeability code bit 1
2-11	See below	DMX Interchangeability code bit 2
1-12	See below	DMX Interchangeability code bit 3

Switch SW1	Interchangeability code															
	A	B	C	D	E	F	G	H	J	K	L	M	N	P	R	
4-9	X	-	X	-	X	-	X	-	X	-	X	-	X	-	X	
3-10	X	X	-	-	X	X	-	-	X	X	-	-	X	X	-	
2-11	X	X	X	X	-	-	-	-	X	X	X	X	-	-	-	
1-12	X	X	X	X	X	X	X	X	-	-	-	-	-	-	-	

Note, In the table:

X= the corresponding switch is set to OFF

- = the corresponding switch is set to ON.

Letters I, O, and Q may not be used as interchangeability codes.

Appendix 5. AS7-VA Jumper settings

Jumpers of the AS7-VA plug-in unit:

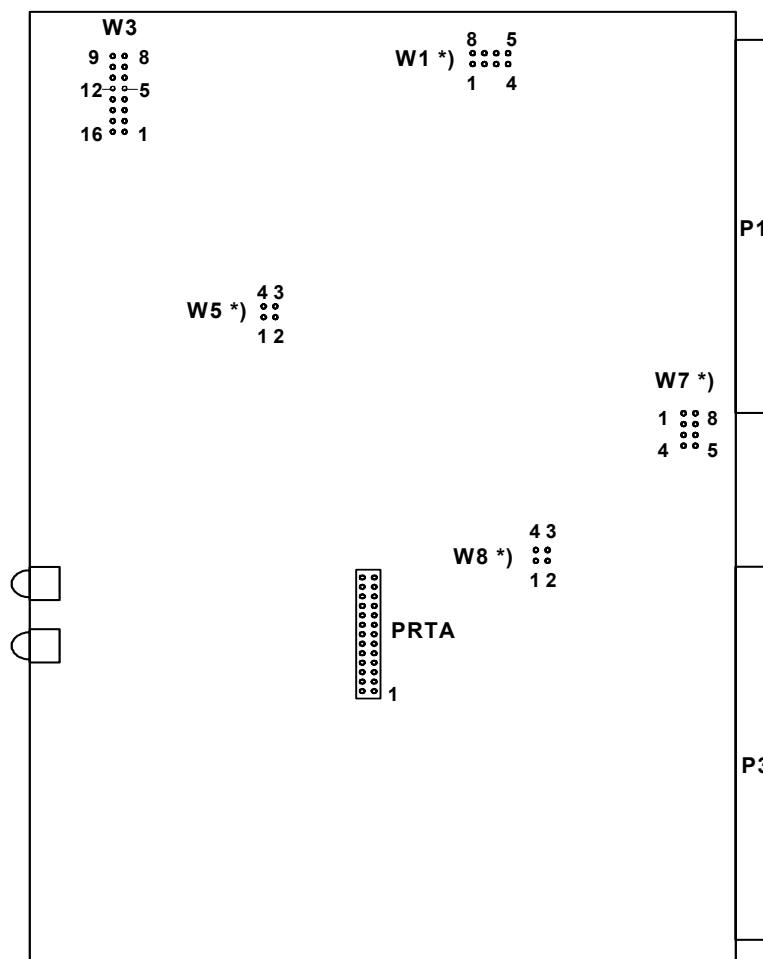

* Alternative settings (**W1, W5, W7 and W8**) are presented in tables below.

Jumper W1, Selection of base address:

Jumper block	Jumper	Selection Criteria	Base Address
W1	1-8	BCSU / OMU	100000H
	2-7	Slot 05	
	3-6		
	1-8	BCSU / OMU	200000H
	2-7	Slot 06	
	4-5		
	1-8	BCSU / OMU	300000H
	2-7	Slot 07	
	1-8	BCSU / OMU	400000H
	3-6	Slot 08	
	4-5		
	1-8	BCSU / OMU	500000H
	3-6	Slot 09	

Jumper W5 DMC- Bus memory space:

W5	1-2 3-4	16-bit DMC-Bus	DMC bus memory space 32 MB, BSC default
	-	32-bit DMC-Bus	

Jumper W7 Interchangeabilty code setting:

Jumper	Interchangeabilty Code														
	A	B	C	D	E	F	G	H	J	K	L	M	N	P	R
W7: 1-8	X	-	X	-	X	-	X	-	X	-	X	-	X	-	X
2-7	X	X	-	-	X	X	-	-	X	X	-	-	X	X	-
3-6	X	X	X	X	-	-	-	-	X	X	X	X	-	-	-
4-5	X	X	X	X	X	X	X	X	X	-	-	-	-	-	-

X = Jumper on

Jumper W8 Timing signal is selection.

W8	1-4	ON	Not available
	-	OFF	BSC default

Appendix 6. AS7-X Jumper Settings

Jumper blocks and switches of the AS7-X plug-in unit:

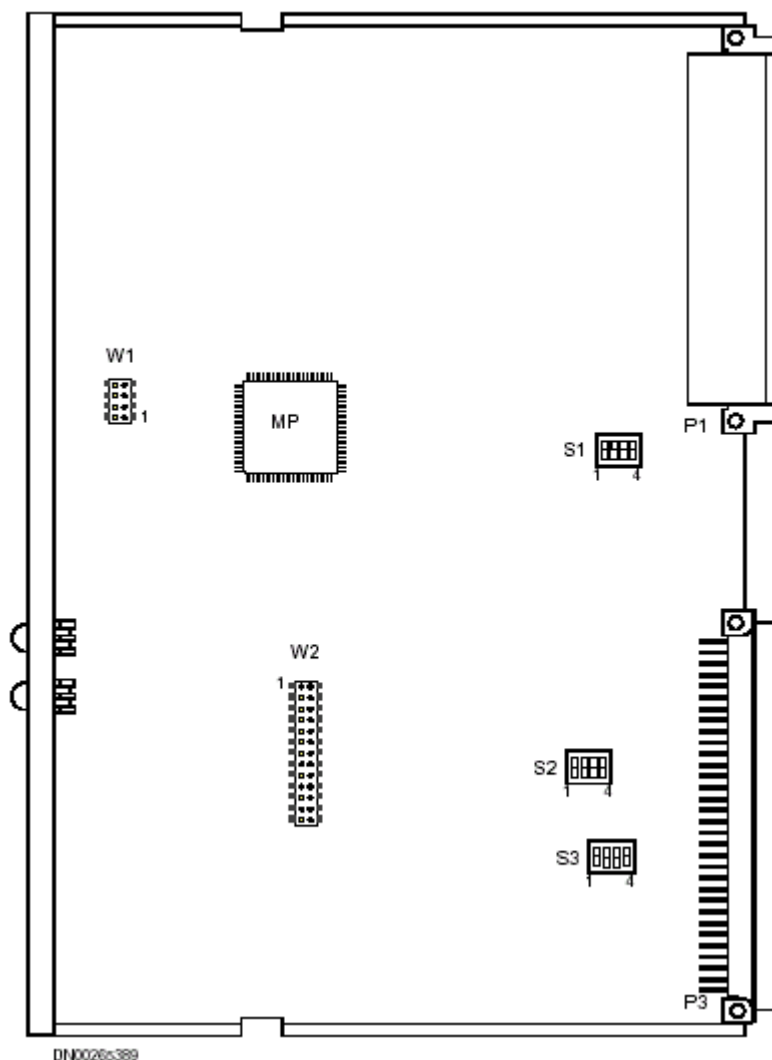

There are no jumpers for settings in CP6MX. All settings are made by using the microswitches S1, S2 and S3. Jumper block W1 is a Lattice circuits programming connector. Jumper block W2 is a PRTA -connector for test purposes.

The use of switches S1, S2 and S3 is presented in the tables below.

Switch 1 = LSB and switch 4 = MSB.

-ON = the switch is in the upper position

-OFF = the switch is in the lower position.

S1, selection of the base address of the DMC bus:

Base +	1 (LSB)	2	3	4 (MSB)
00000H	Off	Off	Off	Off
10000H	On	Off	Off	Off
20000H	Off	On	Off	Off
30000H	On	On	Off	Off
40000H	Off	Off	On	Off
50000H	On	Off	On	Off

Selection of base address:

Selection Criteria	Base Address
BCSU / OMU Track 05	100000H
BCSU / OMU Track 06	200000H
BCSU / OMU Track 07	300000H
BCSU / OMU Track 08	400000H
BCSU / OMU Track 09	500000H

S2, selection of the interchangeability code:

Code	Jumper settings			
	1 (LSB)	2	3	4 (MSB)
A	Off	Off	Off	Off
B	On	Off	Off	Off
C	Off	On	Off	Off
D	On	On	Off	Off
E	Off	Off	On	Off
F	On	Off	On	Off
G	Off	On	On	Off
H	On	On	On	Off
J	Off	Off	Off	On
K	On	Off	Off	On
L	Off	On	Off	On
M	On	On	Off	On
N	Off	Off	On	On
P	On	Off	On	On
R	Off	On	On	On

S3, selection of timing signal and type of DMC bus:

Selection	Explanation
S3-1	Selection of timing signal either for cartridge mechanics (no redundancy) or for subrack mechanics (2n redundancy). On: When the switch is closed, 2n redundant timing signal is selected Off: When the switch is open, non-redundant timing signal is selected
S3-2	Selection of either 32-bit or 16-bit DMC bus. Off: When the switch is open, the 32-bit bus selected On: When the switch is closed, the 16-bit bus selected
S3-3	Not in use
S3-4	Not in use

BSC defaults:

S3-1 OFF, Non-redundant timing signal is selected

S3-2 ON, 16-bit DMC-Bus

S3-3 Not in use

S3-4 Not in use

Appendix 7. SW64B Jumper Settings

SW64B C 8790, jumpers of the plug-in unit:

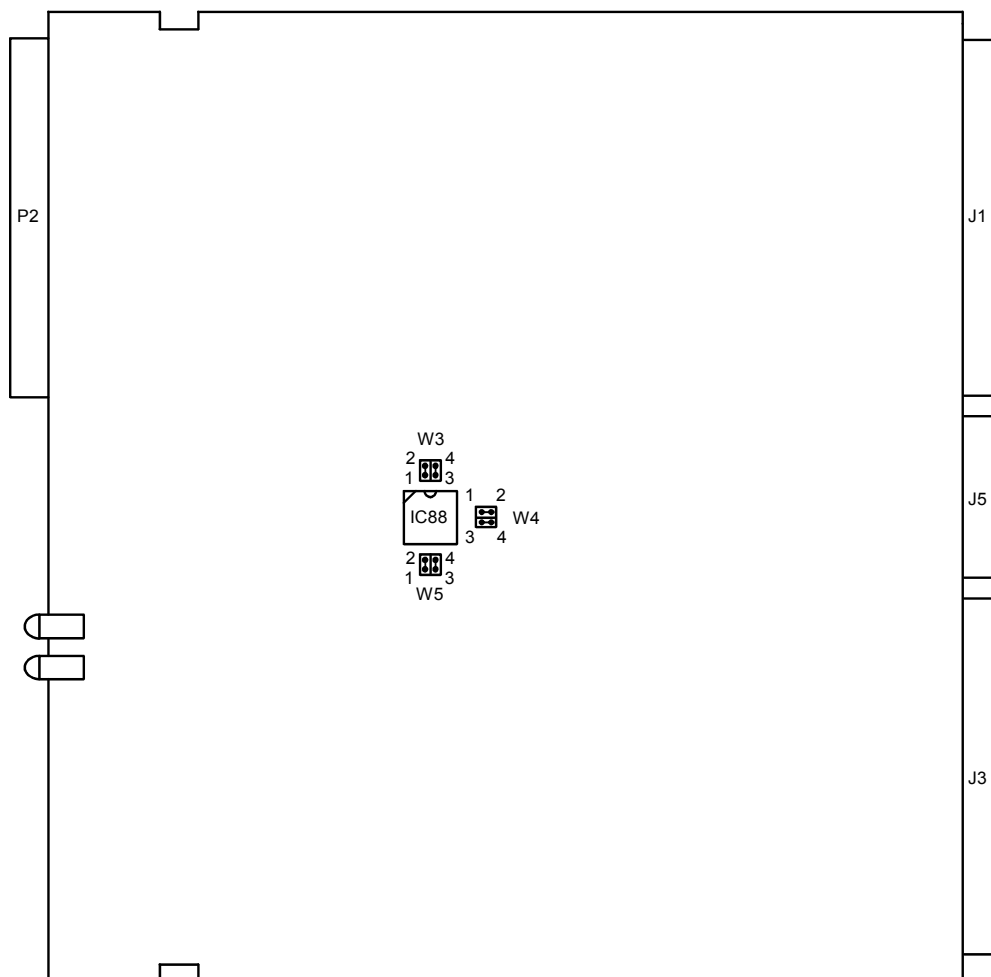

Standard settings:

Jumper block	Connection
W3	1-2 3-4
W4	1-2 3-4
W5	1-2 3-4

Appendix 8. Installation of Cartridges

The plug-in units are housed in cartridges mounted on cartridge shelves. The width of the cartridge shelves is 730 mm (28.7 in). The mechanical structure of a single cartridge is presented in the following figure. Note that the cartridges are grounded to the rack with special grounding parts (referred to as number 6 in the Figure).

Mounting of a cartridge:

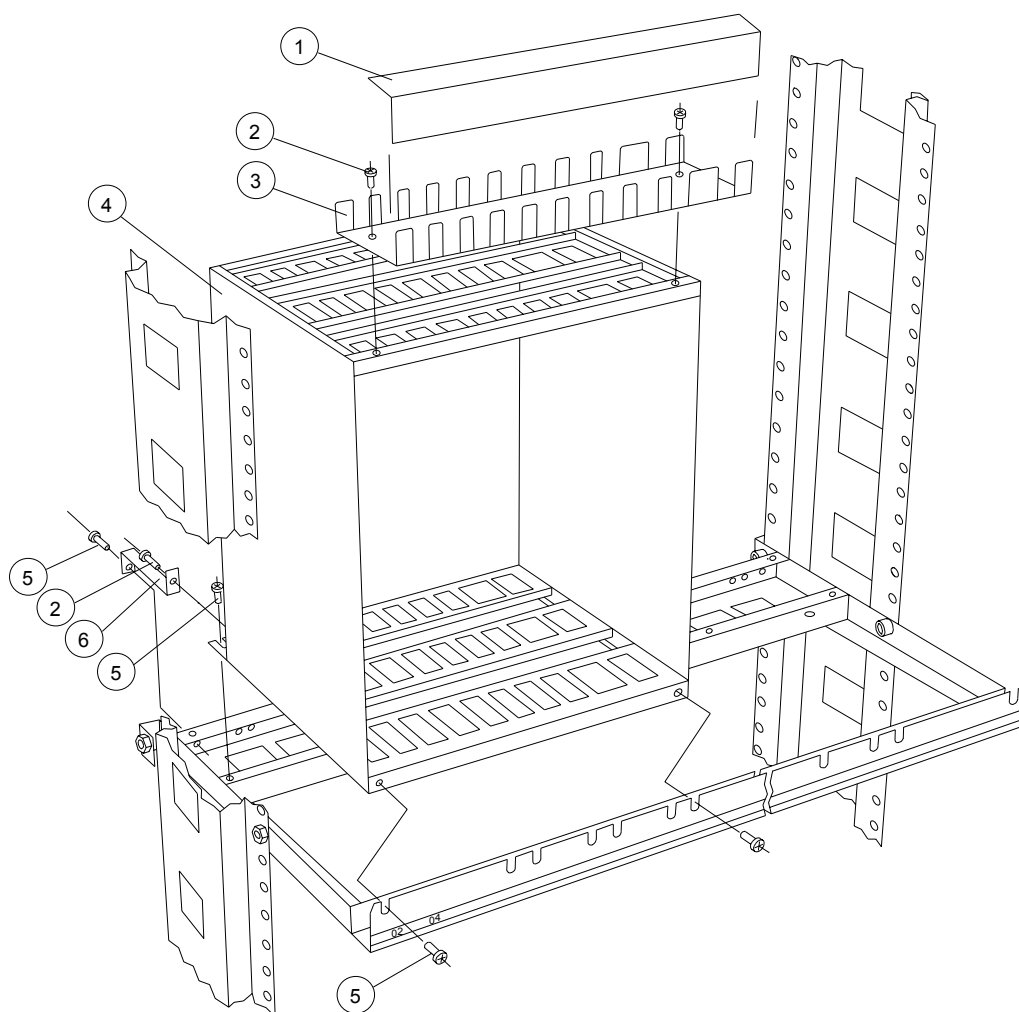

Cartridge mounting parts:

No.	Name
1	Cover plate
2	Screw 2.9 x 9.5
3	Cable trough
4	Cartridge
5	Allen screw 4 x 12
6	Grounding part

Interconnection Cabling

This chapter describes the positions and routing of the cabling located inside the BSC racks. The cables are prefabricated. Interconnection cables are used for cabling between the cartridges and racks of the BSC. The cables are prefabricated to the appropriate length and have connectors at both ends. The cables should be placed so that there are no sharp edges and so that they are not pulled too tight. Place them evenly in the supporters behind the racks, so that they will not hamper the installation of the back doors and their girders later.

The Cable table has nine columns which contain the following information:

- The first column (No) shows the identification number of the cable. Both ends of the cable are marked with a label with this number on it.
- The second column (RACK) shows the name of the rack where the first end of the cable is connected.
- The third column (FE) shows the name of the Functional Entity where the first end of the cable is connected.
- The fourth column shows the co-ordinate of the connector where the first end of the cable is connected. The structure of the co-ordinate is explained in the section below.
- The fifth, sixth and seventh columns show the same information about the other end of the cable as the second, third and fourth columns.
- The eighth column shows the type number of the cable. The type of the cable and connectors are coded in the first three letters and the length of the cable is shown in the following three numbers. The length is given in centimetres if there is a letter C after the three numbers and in decimetres if there is no letter after the three numbers.
- The ninth column shows the use of the cable.

Structure of the co-ordinate

The co-ordinate is a group of eight, nine or ten digits, which are divided into three subgroups:

The first subgroup is a vertical co-ordinate of three numbers. It shows the height of the functional entity in the rack. Eight different heights are used in the BSC. Six of these are used for shelves where cartridges are located and two for power distribution units at the top of the rack. Vertical co-ordinates and their meanings are explained in the following table:

002 = the lowest shelf

030	=	the second lowest shelf
058	=	the third lowest shelf
088	=	the fourth lowest shelf
120	=	the fifth lowest shelf
148	=	PSFP at the top of the rack
152	=	PSA20 at the top of the rack

The second subgroup is a horizontal co-ordinate of two numbers and one letter. The two numbers indicate the horizontal position of the functional entity on the shelf and the letter shows whether the connector where the cable will be connected is located in the back (B) or in the front (F) of the subrack. The horizontal co-ordinates used in the BSC are:

01, 03	=	the rightmost cartridge, PSFP or PSA20 on the shelf
13, 19	=	the middle cartridge on the shelf
25,27,33,37	=	the leftmost cartridge, PSFP or PSA20 on the shelf

The third subgroup states the exact position of the connector inside the functional entity. The position is always marked on the functional entity by a label. The number of digits in this subgroup depends on the type of the functional unit and the use of the cable:

Two digits, the letter P and one number, are used for power distribution connectors of PSFP.

Three digits, the letters PL and one number are used for power distribution connectors in different cartridges for cables coming from PSFP.

Three or four digits, the letters LL and one or two numbers are used for connectors for the power distribution cables between two cartridges.

Three digits, the numbers 01 and one number separated by a dash, are used for alarm connectors in PSFP and PSA20.

Four digits, two numbers and the letter R or S followed by one number, are used for all other connectors. The letter shows the vertical co-ordinate inside a cartridge and the first two numbers show the horizontal co-ordinate inside a cartridge. The last number states in which of the eight possible positions inside a Euroconnector the cable is located.

Identification of interconnection cables:

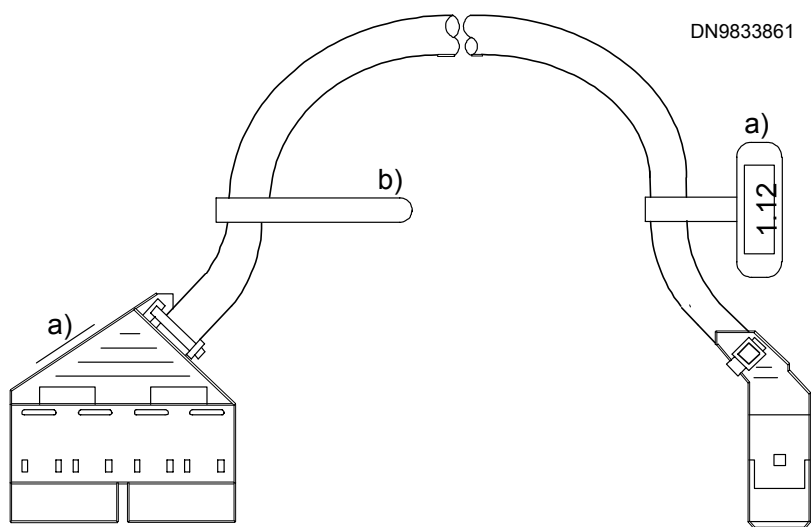

a) SEQUENTIAL NUMBER OF CABLE, E.G. 1.12
 OME RACK _____
 SEQUENTIAL NUMBER _____

b) CABLE IDENTIFICATION LABEL

EXAMPLE: CEB 070 C17425 BCDEF 01 9504 2 1114

NAME _____
 LENGTH [dm] _____
 ID CODE _____
 INTERCHANGEABILITY CODE _____
 VERSION _____
 YEAR AND WEEK OF MANUFACTURING _____
 PLACE OF MANUFACTURING _____
 SERIAL NUMBER _____

Equipping of the Euroconnector with 1/8, 1/4 and 1/2 connectors:

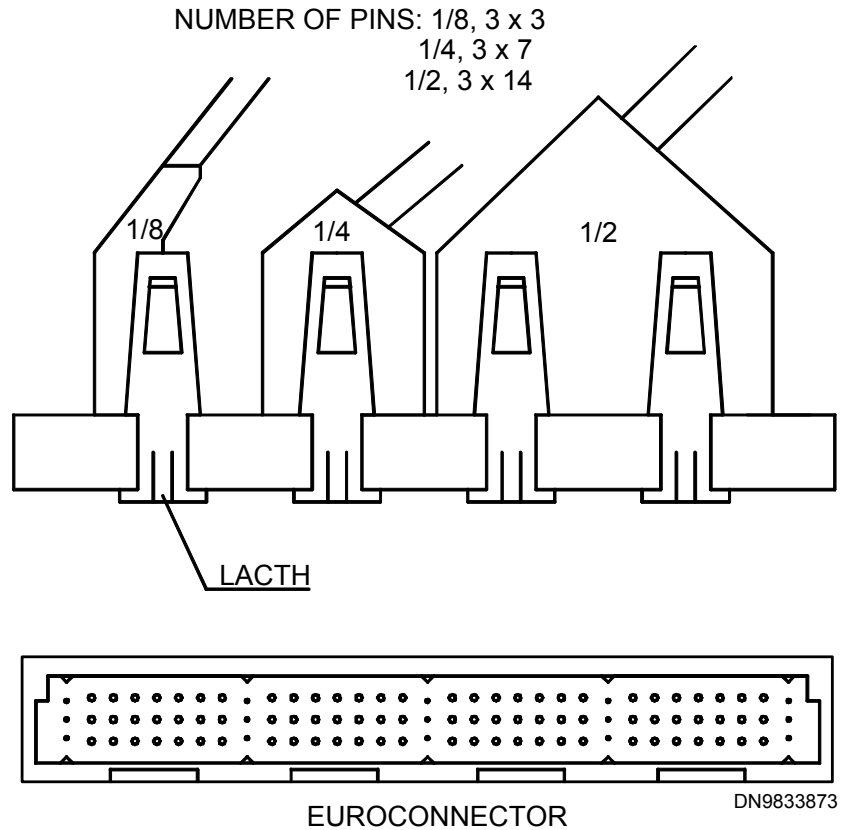

Internal power cabling

Each BCBE and BCEE rack contains two Power Supply Fuse Panels (PSFP). The PSFPs distribute the power from the PSA 20 unit via 10 A fuses (F0 to F11) to the cartridges in the rack (see Table 5). The cartridges are cabled to connectors (P0 to P11).

Figure, Front view of the PSFP:

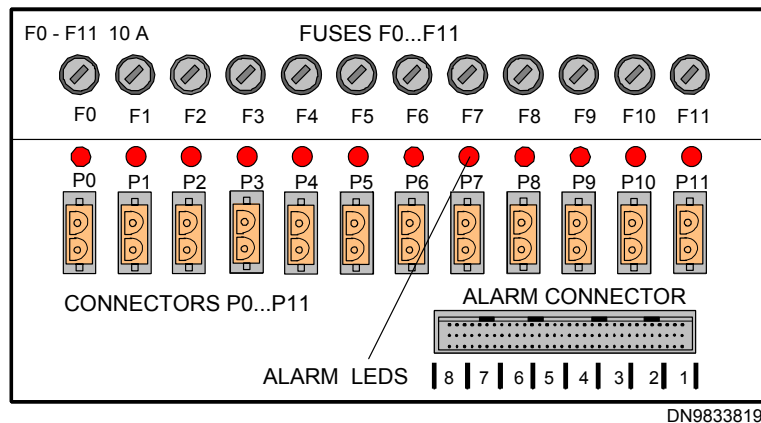

Appendix 9. SERO-T C 8652 Jumper Settings

Strappings and read-only memory circuits of the plug-in unit SERO-T:

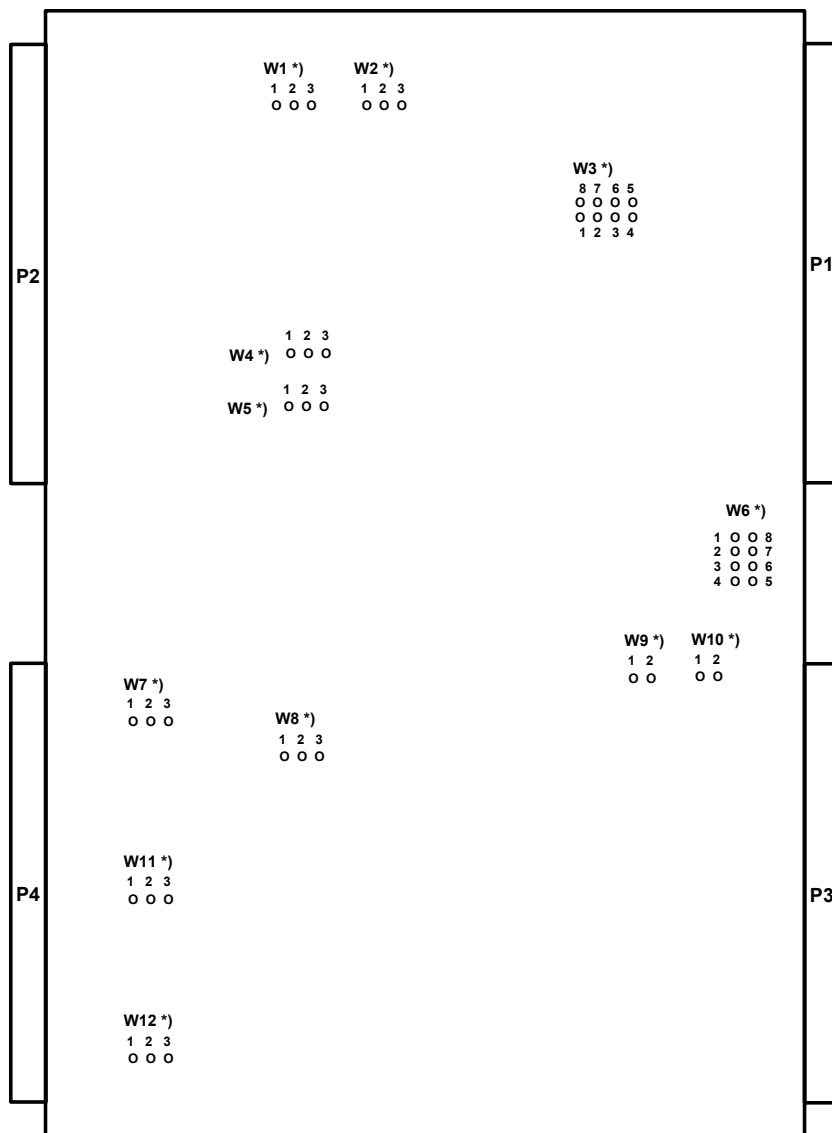

*) Alternative settings are presented in table.

Alternative settings:

Base address selection (strapping group W3):

Base address	Connection (W3)				Note
	1 - 8	2 - 7	3 - 6	4 - 5	
E000H	X	X	X	X	Default
E100H		X	X	X	
E200H	X		X	X	
E300H			X	X	
E400H	X	X		X	
E500H		X		X	
E600H	X			X	
E700H				X	
E800H	X	X	X		
E900H		X	X		
EA00H	X		X		
EB00H			X		
EC00H	X	X			
ED00H		X			
EE00H	X				
EF00H					

X = Connected.

The selection of the clock signal of the oscillator (strapping group W9):

Criteria	Connection (W9)	Note
Clock signal is connected	1 - 2	Default
Clock signal is disconnected	-	

The selection of the CTS signal and channels (strapping groups W1, W2, W4, W5, W7, W8, W11 and W12).

Strapping group	Connection	Note
W1	1 - 2	V.11 interface in channel 2
	2 - 3	V.28 interface in channel 2, Default
W2	1 - 2	V.11 interface in channel 3
	2 - 3	V.28 interface in channel 3, Default
W4	1 - 2	V.11 interface in channel 0
	2 - 3	V.28 interface in channel 0, Default
W5	1 - 2	V.11 interface in channel 1
	2 - 3	V.28 interface in channel 1, Default
W7	1 - 2	V.11 interface in channel 6
	2 - 3	V.28 interface in channel 6, Default
W8	1 - 2	V.11 interface in channel 7
	2 - 3	V.28 interface in channel 7, Default
W11	1 - 2	V.11 interface in channel 5
	2 - 3	V.28 interface in channel 5, Default
W12	1 - 2	V.11 interface in channel 4
	2 - 3	V.28 interface in channel 4, Default

The interchangeability code selection (strapping group W6)

Connection (W6)	Interchangeability code														
	A	B	C	D	E	F	G	H	J	K	L	M	N	P	R
1 - 8	X		X		X		X		X		X		X		X
2 - 7	X	X			X	X			X	X			X	X	
3 - 6	X	X	X	X					X	X	X	X			
4 - 5	X	X	X	X	X	X	X	X							

X = connected

The connection of the interrupt signal (strapping group W10)

Criteria	Connection (W10)	Note
The interrupt signal is connected	1 - 2	subrack mechanics in use
The interrupt signal is disconnected	-	cartridge mechanics in use, Default

Appendix 10. ET5C ET Cartridge Jumper Settings

Jumper blocks of the ET5C cartridge:

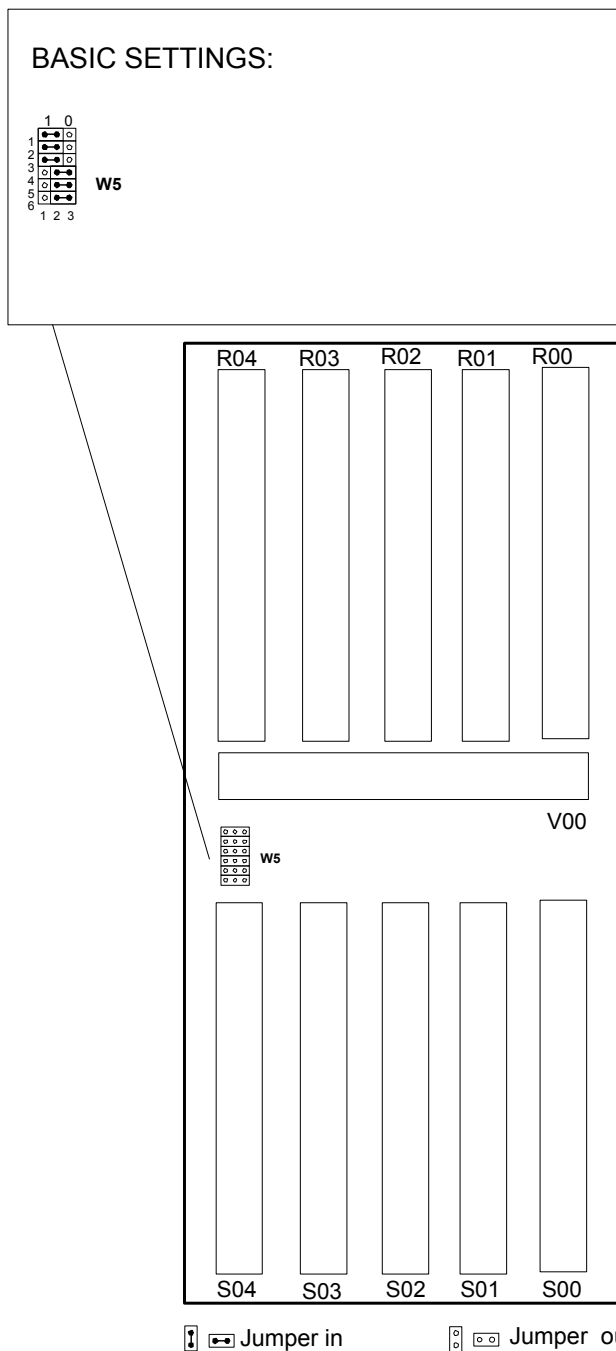

Appendix 11. ET2A C 8781 Jumper Settings

Jumpers and EPROM circuits of plug-in unit ET2A:

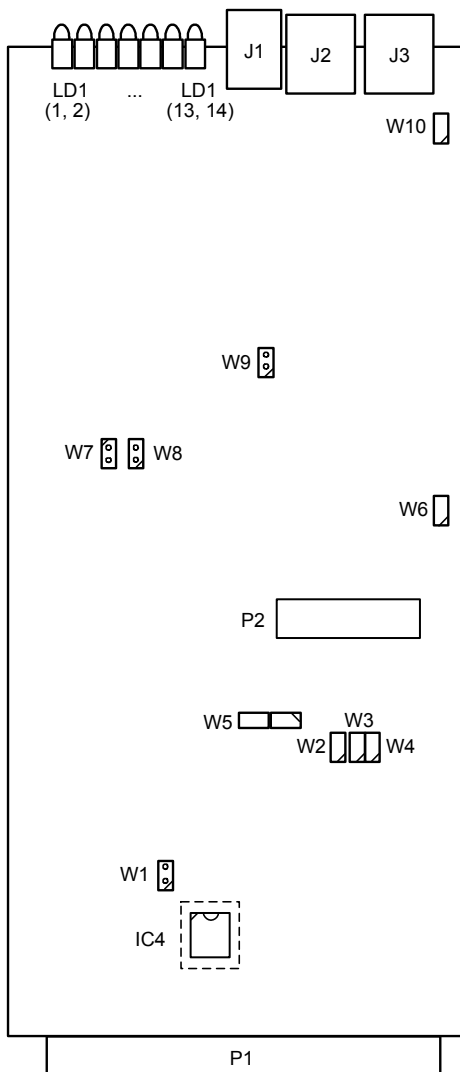

Standard settings:

Jumper block	Connection	Note
W1	-	Ground potential for test use
W3	1-2	Disconnection of processor clock signal (for testing)
W4	1-2	Disconnection of processor RESET signal (for testing)
W6	1-2	Disconnection of 6.176 MHz clock signal (for testing)
W7	-	-5V (pin 2) and ground (pin 1) for test purposes
W8	-	+5V (pin 1) and ground (pin 2) for test purposes
W9	-	Ground potential for test use
W10	-	Overvoltage ground separated from digital ground

Alternative settings:

The jumper which can be read by the software (W2).

Selection criteria	Connection	Note
Chosen setting accessible to the program (spare)	W2: 1-2	Not currently used

Selection of the interchangeability code of the plug-in unit (jumper block W5; The currently valid interchangeability code is set at the factory)

Connection	Interchangeability code															
	A	B	C	D	E	F	G	H	J	K	L	M	N	P	R	S
W5: 1-2	X		X		X		X		X		X		X		X	
3-4	X	X			X	X			X	X			X	X		

Selection of the interchangeability code.

- in the above interchangeability code table, X = the corresponding connection is made, and blank = the corresponding connection is not made

Appendix 12. WDDC Cartridge Jumper Settings

Jumper setting in BSC2A:

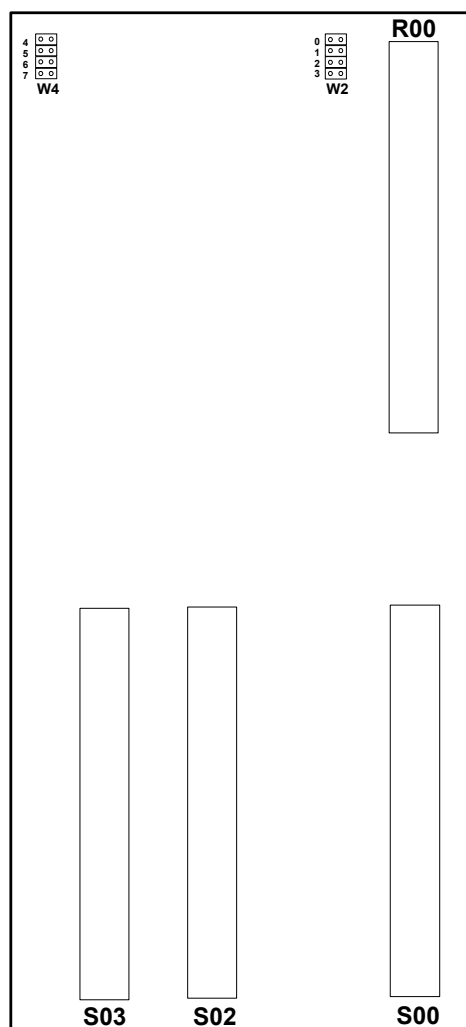
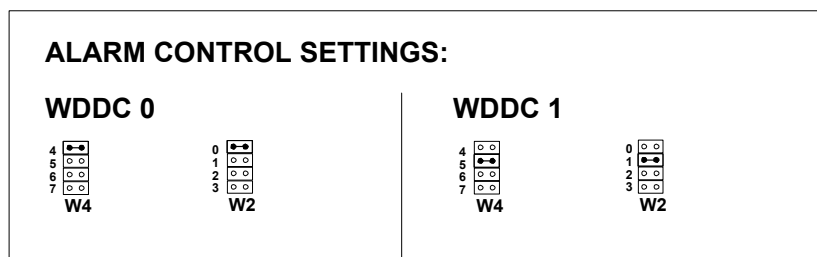

Jumper in Jumper out

Note: When WDDC is used in BSC2i, both WDDC0 and WDDC1 cartridges are jumpered as a WDDC0.

Appendix 13. AS7-US C 8905 Jumper Settings

Jumpers of the plug-in unit:

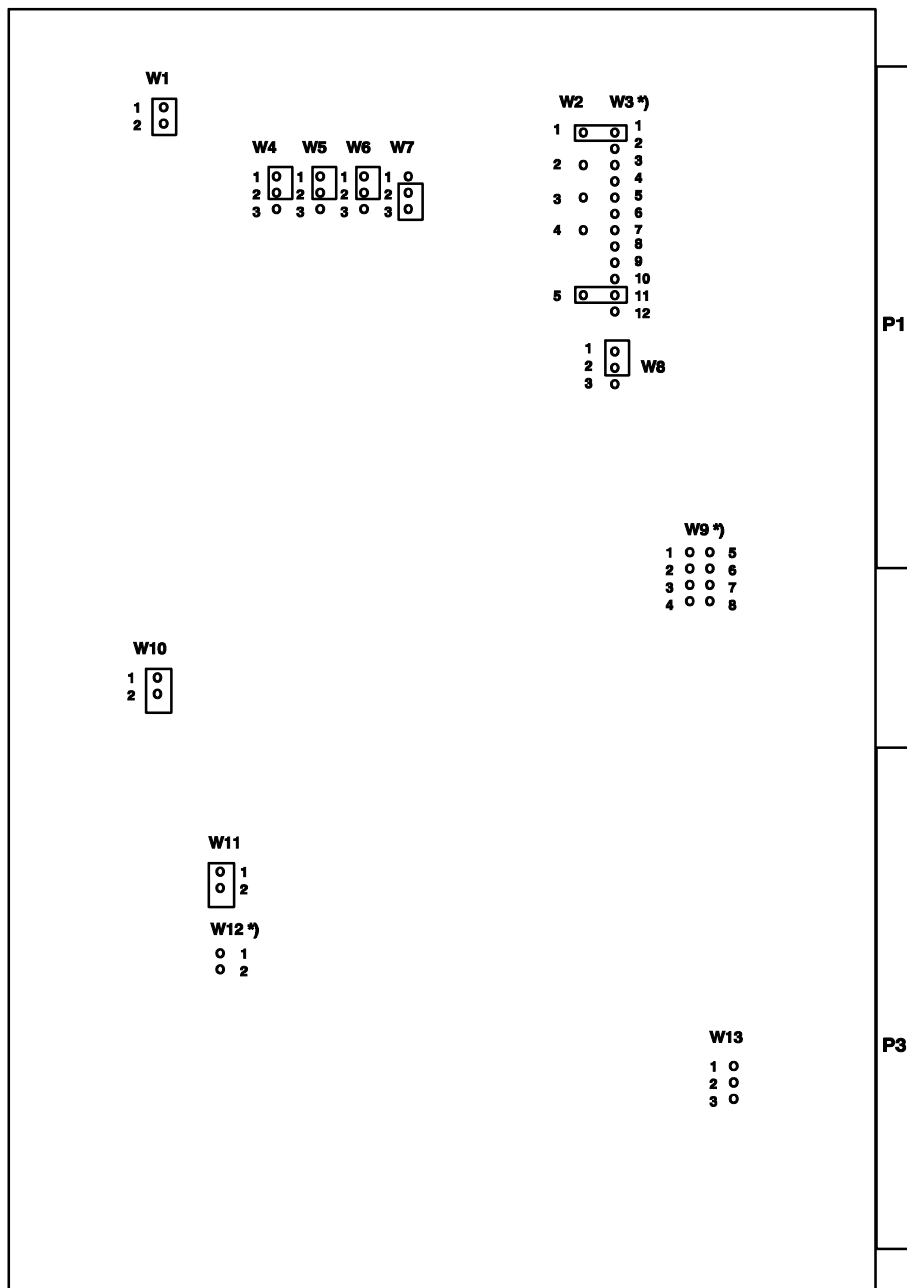

*) Alternative settings are presented in the tables below.

Standard settings:

Jumper block	Connection	Note
W1	1-2	
W2	5 - W3/11 1 - W3/1	Bit A19 not in use Bit A24 not in use
W4	1-2	READY signal not delayed
W5	1-2	READY signal not delayed
W6	1-2	READY signal not delayed
W7	2-3	One WAIT state is generated
W8	1-2	Memory area 1M visible to DCM bus
W10	1-2	
W11	1-2	
W13	-	

Alternative settings:

Selection of the memory space of the multi-protocol circuit (R8071) (jumper block W12)

Selection criteria	Connection	Note
AS7-U/AS7-US is used in digital X.25 interface	W12: -	R8071 memory space 64 kbytes
AS7-U/AS7-US is not used in digital X.25 interface	W12: 1-2	R8071 memory space 256 kbytes, Default setting

Selection of base address (jumper block W3)

Plug-in unit location	Connection	Note
MC1C (BCSU) track 05	W3: 3-4 5-6 7-8	Base address 100000H
MC1C (OMU) track 06, MC1C (BCSU) track 06	W3: 3-4 5-6 9-10	Base address 200000H
MC1C (OMU) track 07	W3: 3-4 5-6	Base address 300000H
MC1C (OMU) track 08 MC1C (BCSU) track 08	W3: 3-4 7-8 9-10	Base address 400000H

- When referring to the base addresses seen from the main processor, the hexadecimal digit 80 or the old E is placed before the address

Setting of the interchangeability code for the plug-in unit (jumper block W9; use of letters I, O and Q as interchangeability codes is not allowed):

Connection	Interchangeability code															
	A	B	C	D	E	F	G	H	J	K	L	M	N	P	R	
W9: 1-5	X	X	X	X	X	X	X	X								
2-6	X	X	X	X					X	X	X	X				
3-7	X	X			X	X			X	X			X	X		
4-8	X		X		X		X		X		X		X		X	

- in the above interchangeability code table, X = the corresponding connection is made, and blank = the corresponding connection is not made.

Appendix 14. MC1C Interchangeability D

Keywords:

MC1C, Cartridge, Interchangeability

Summary:

Cartridge DMC-bus reset signal sensitivity improvement

Description:

MC1C Multicomputer Cartridge
Product ID C08680
Interchangeability Change C -> D (CM4571)

Description of change:

The _RESET-signal of DMC-bus is now terminated to the +5V in order to improve noise immunity in a bus during the reset situation.

The _RESET-signal is used to cause a warm reset to the plug-in units in a DMC-bus.

Instructions:

Usage/equipping:

The usage is same as with the older ones, there is no extra requirement.

Required actions:

The older interchangeability B is allowed only when BSC2 product. For BSC2i products MC1C interchangeability has to be in interchangeability C level. These are still valid and acceptable for usage with mentioned requirements. No changes required for them.

Note:

BSC deliveries with new MC1C interchangeability D will start on weeks 1-3/01. For more detailed information about the deliveries, please contact your local Nokia representative.