

2.0 Lowband PCB 8485658Z01 / Schematics

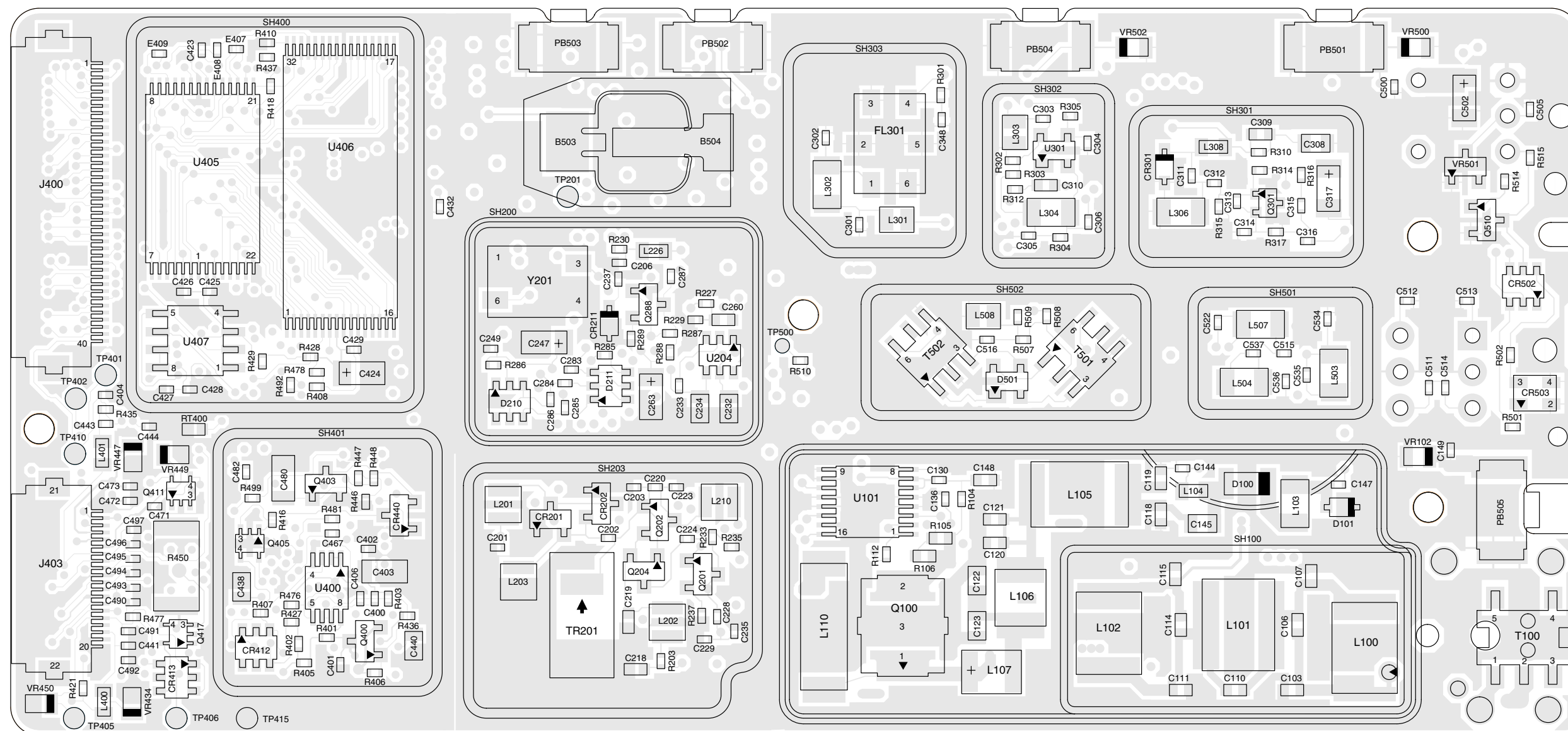

FL0830474-O

Lowband (30-50 MHz) Main Board Top Side

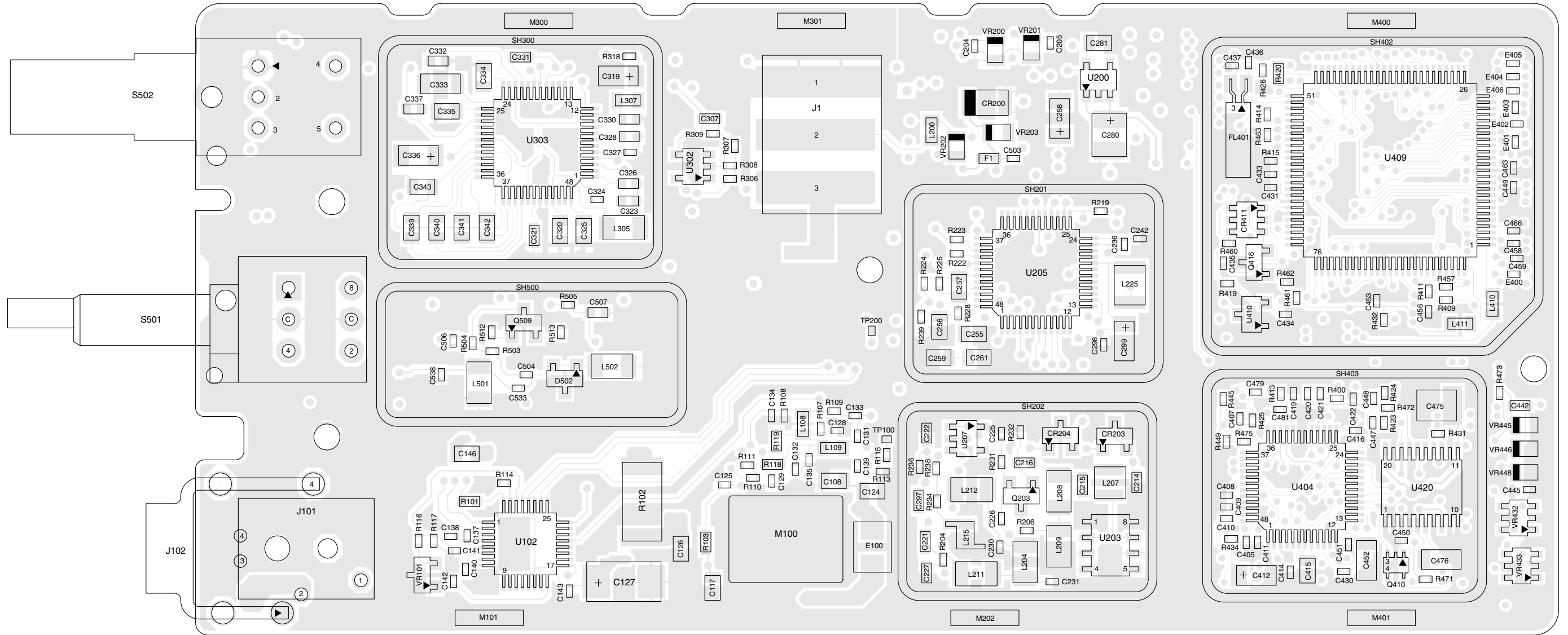

FL0830475-O

Lowband (30-50 MHz) Main Board Bottom Side

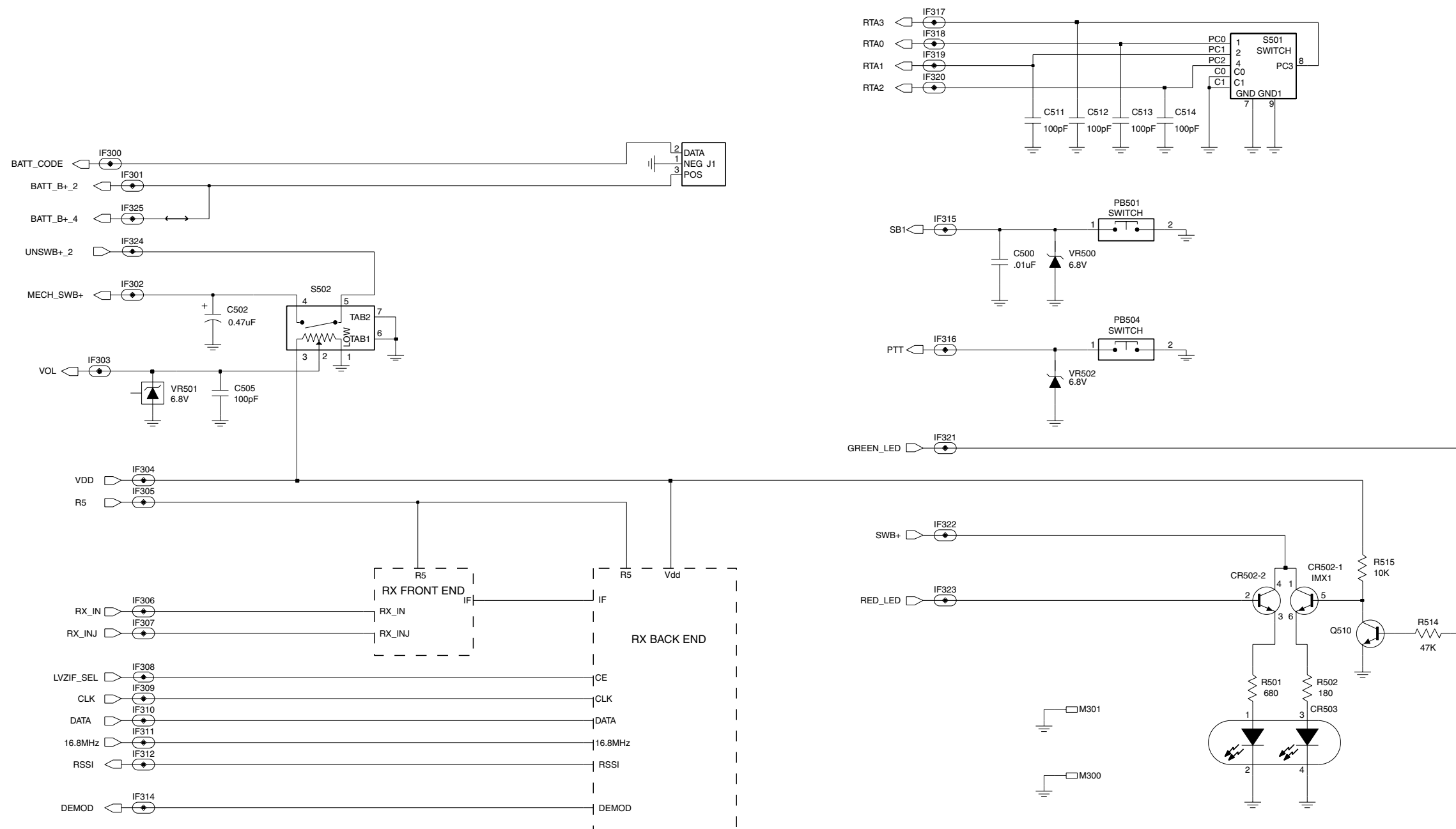

FL0830470-O

Lowband (30-50 MHz) Receiver Overall Schematic

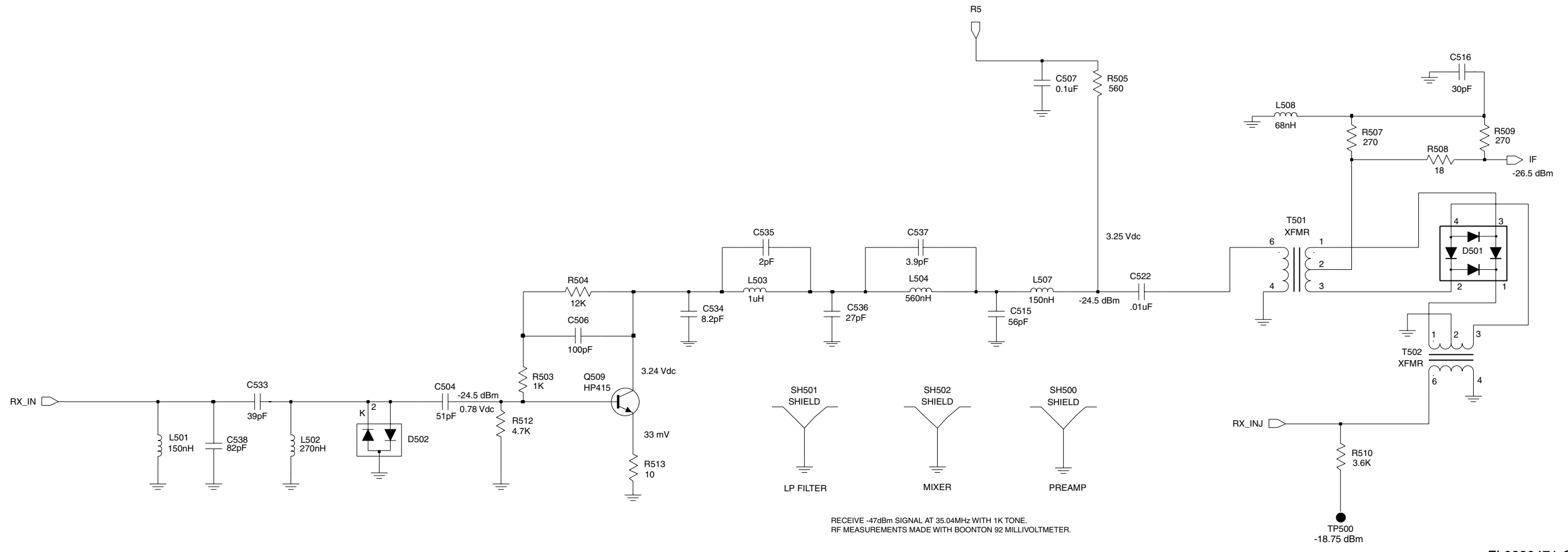

FL0830471-O

Lowband (30-50 MHz) Receiver Front End

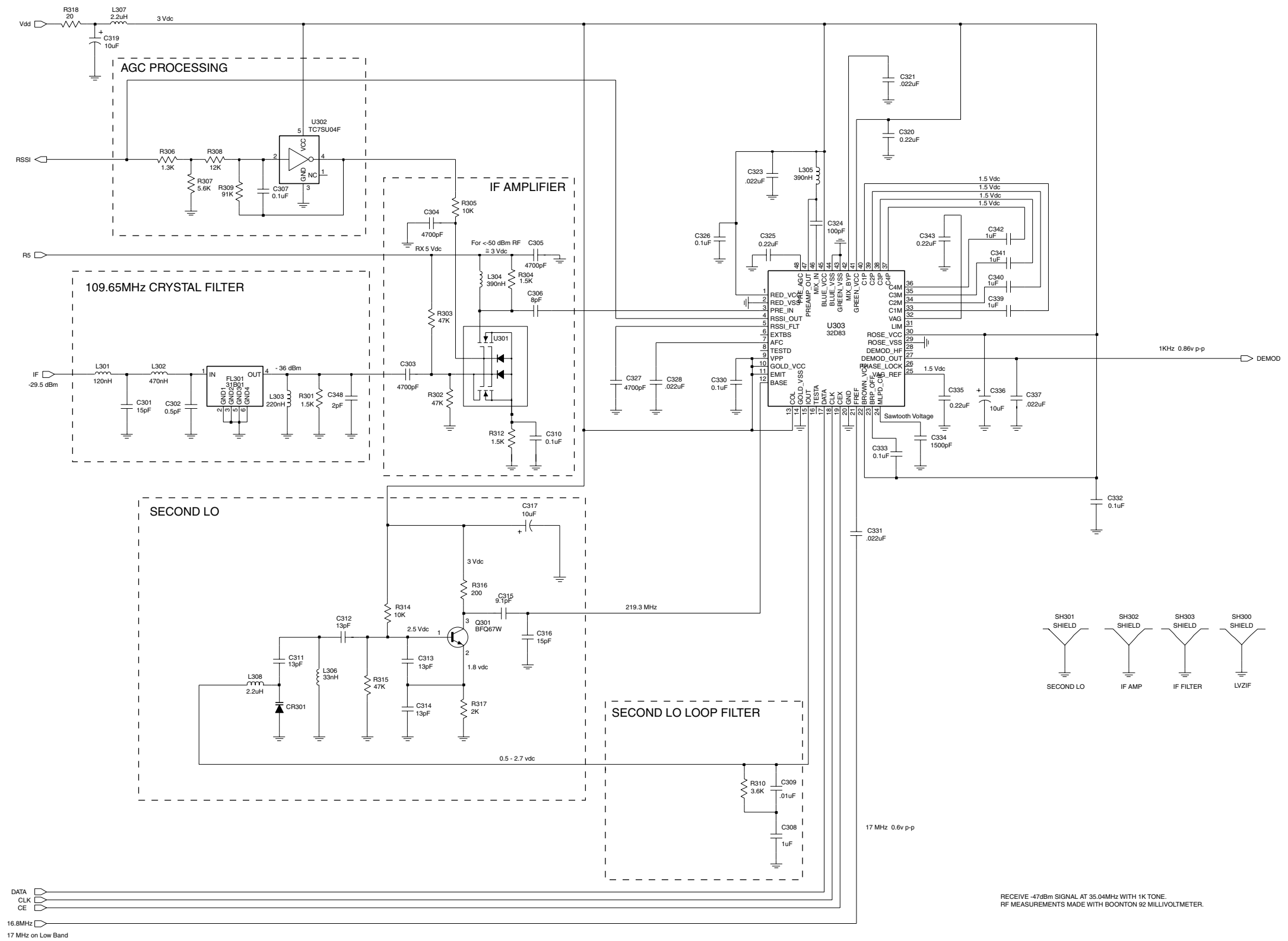

FL0830472-O

Lowband (30-50 MHz) Receiver Back End

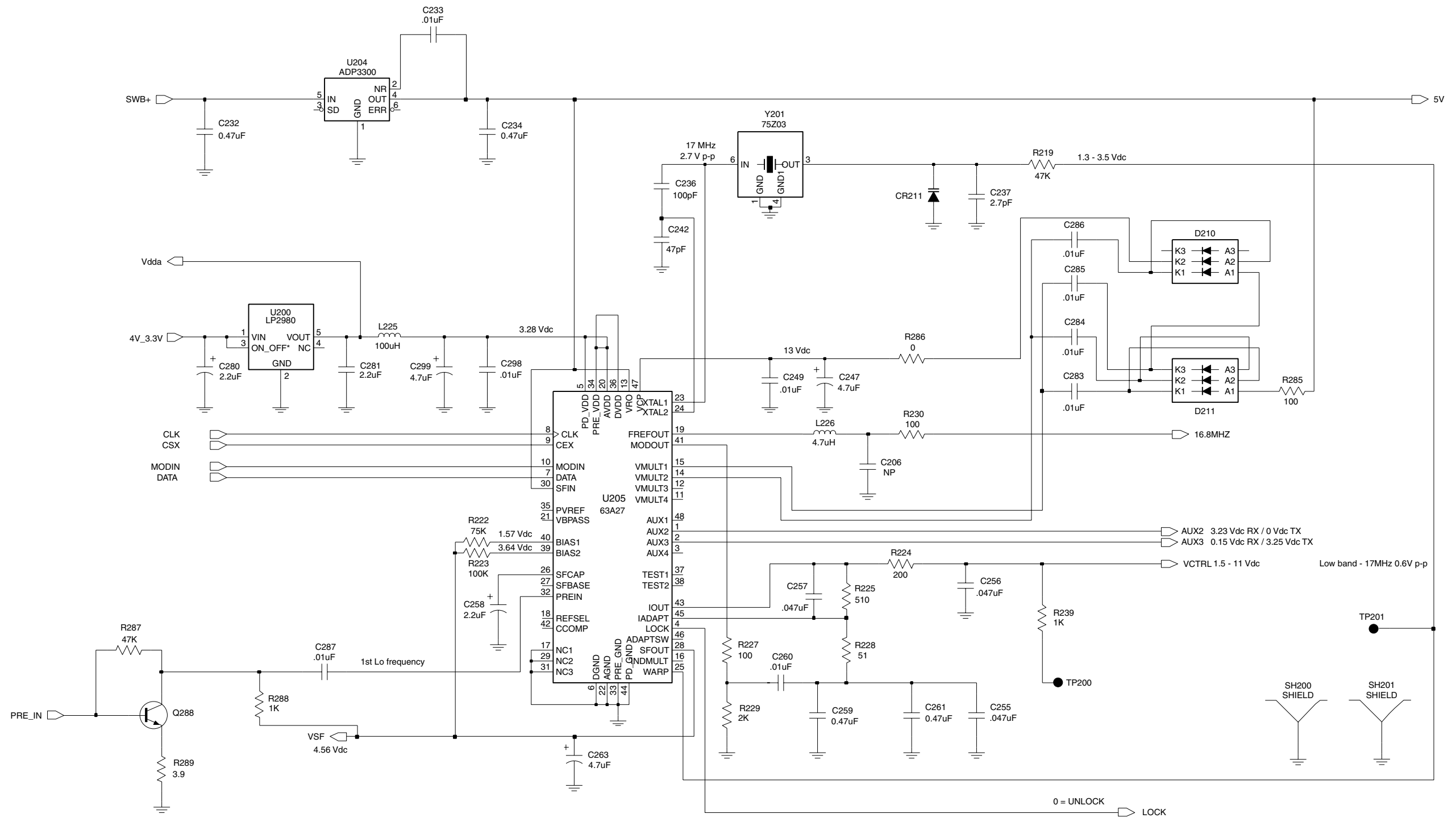

FL0830468-O

Lowband (30-50 MHz) Synthesizer

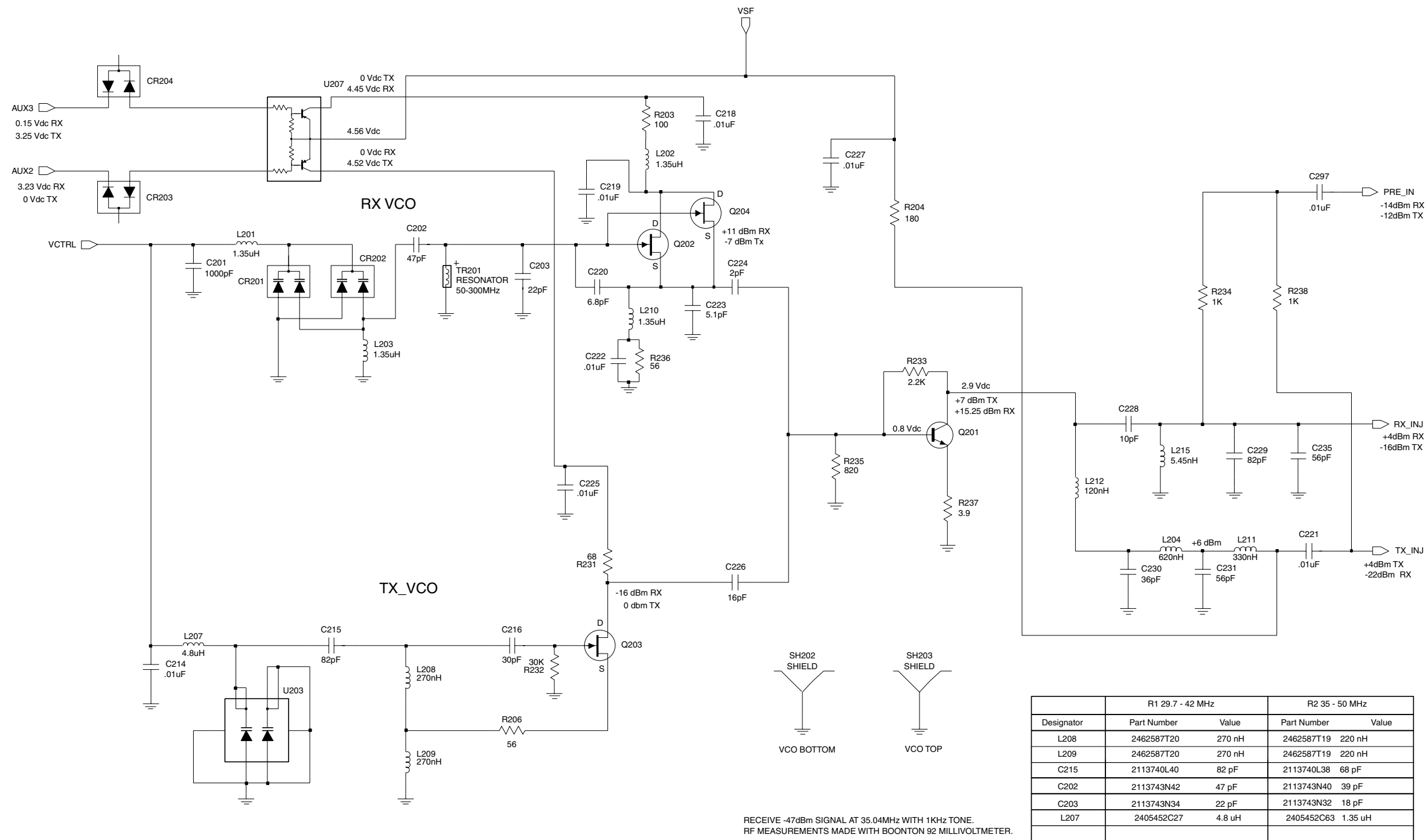

FL0830269-O

Lowband (30-50 MHz) Voltage Controlled Oscillator

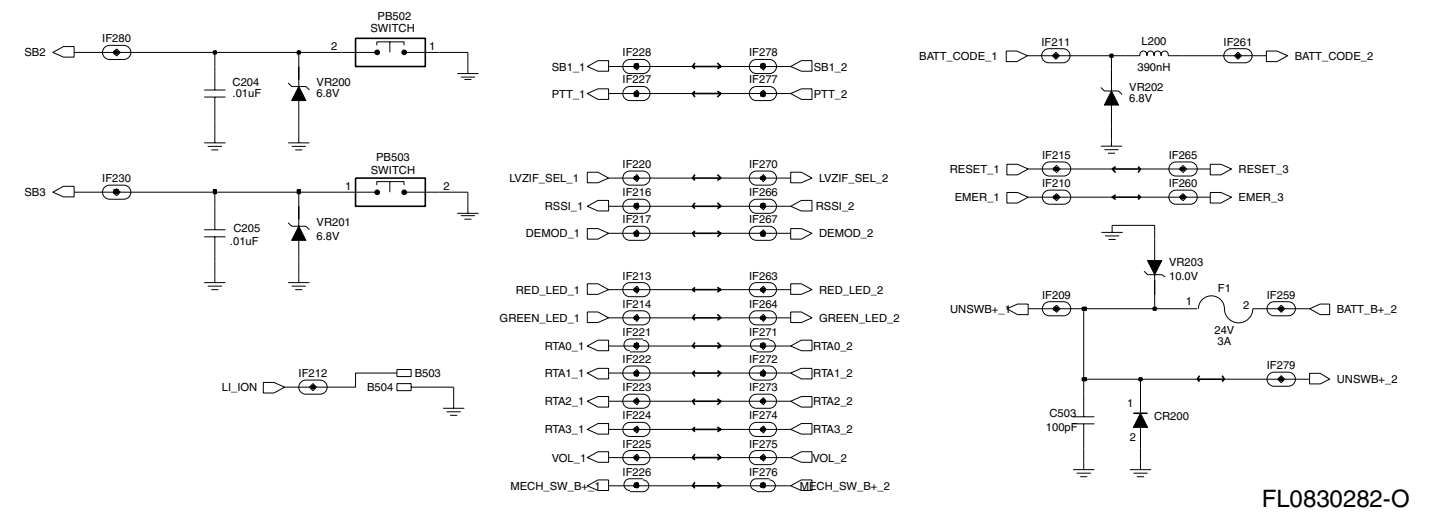
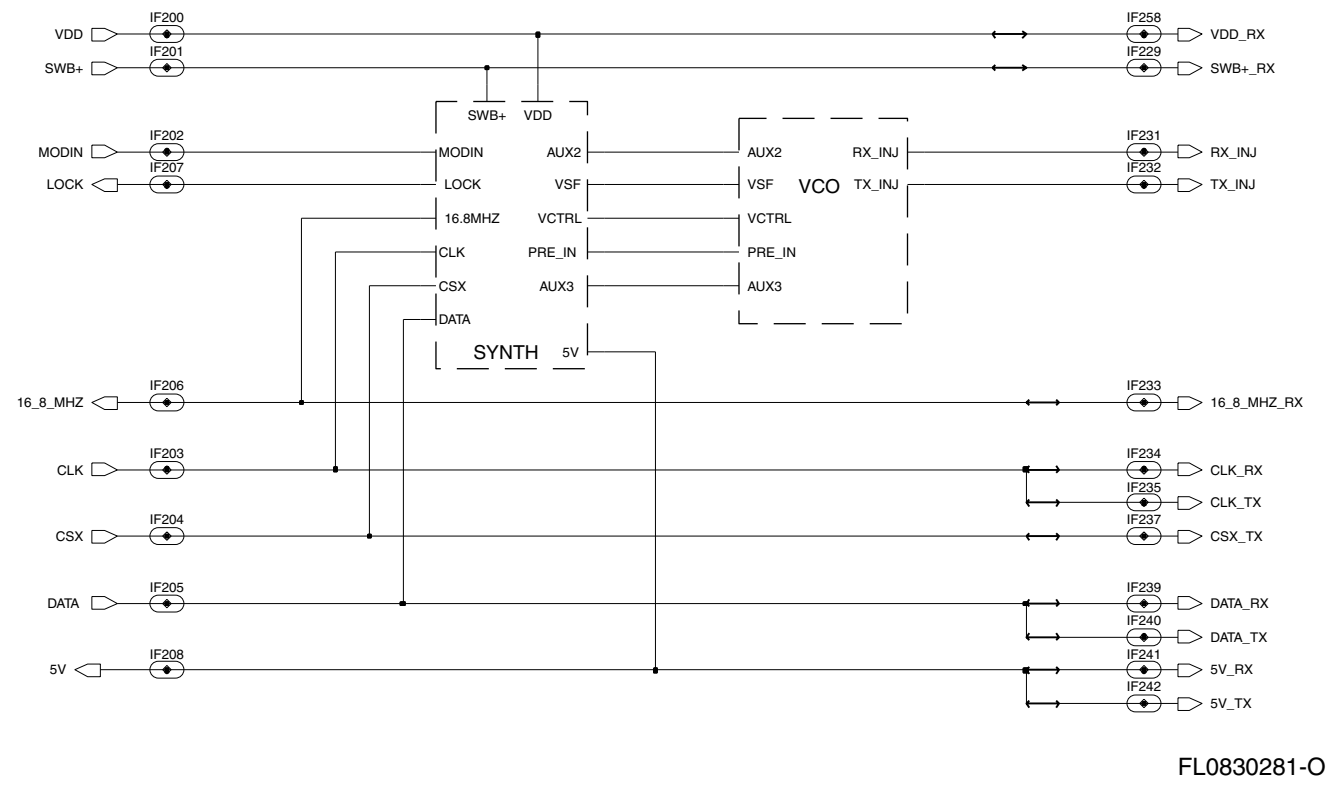

Lowband (30-50 MHz) Overall Synthesizer Schematic

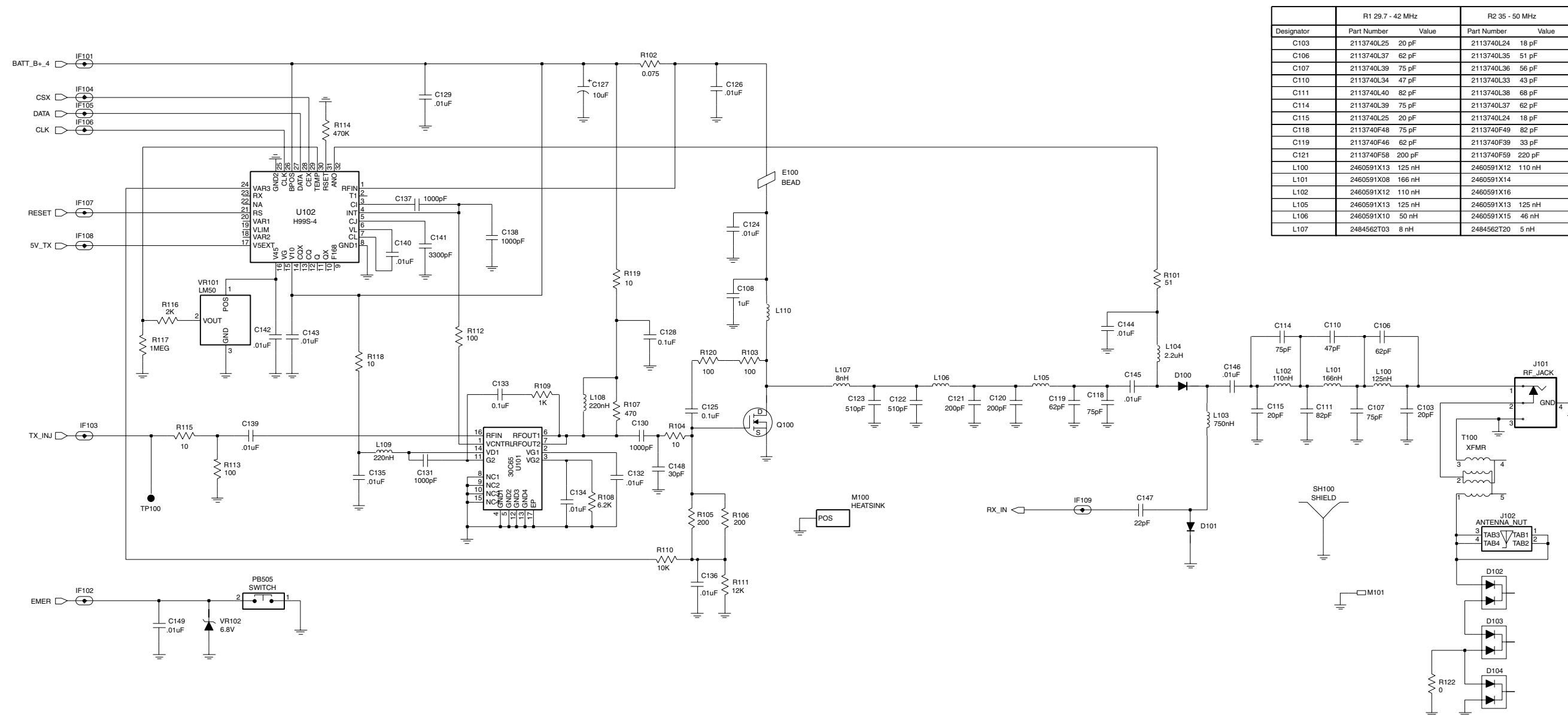

FL0830473-A

Lowband (30-50 MHz) Transmitter

3.0 Lowband PCB 8485658Z01 Parts List

Circuit Ref	Motorola Part No.	Description
C103	2113740L25	20pF
C103*	2113740L24	18pF
C106	2113740L37	62pF
C106*	2113740L35	51pF
C107	2113740L39	75pF
C107*	2113740L36	56pF
C108	2113743F16	1.0uF
C110	2113740L34	47pF
C110*	2113740L33	43pF
C111	2113740L40	82pF
C111*	2113740L38	68pF
C114	2113740L39	75pF
C114*	2113740L37	62pF
C115	2113740L25	20pF
C115*	2113740L24	18pF
C118	2113740F48	47pF
C118*	2113740F49	82pF
C119	2113740F46	62pF
C119	2113740F39	33pF
C120	2113740F58	200pF
C121	2113740F58	200pF
C121*	2113740F59	220pF
C122	2113740A72	510pF
C123	2113740A72	510pF
C124	2113741A45	56pF
C125	2113743M24	0.01uF
C126	2113741A45	56pF
C127	2311049A18	10uF
C128	2113743M24	0.01uF
C129	2113743L41	0.01uF
C130	2113743L17	1000pF
C131'	2113743L17	1000pF
C132	2113743L41	0.01uF
C133	2113743M24	0.01uF
C134	2113743L41	0.01uF
C135	2113743L41	0.01uF
C136	2113743L41	0.01uF
C137	2113743L17	1000pF
C138	2113743L17	1000pF
C139	2113743L41	0.01uF
C140	2113743L41	0.01uF
C141	2113743L29	3300pF
C142	2113743L41	0.01uF
C143	2113743L41	0.01uF
C144	2113743L41	0.01uF
C145	2113741A45	56pF
C146	2113741A45	56pF
C147	2113743N34	22pF

Circuit Ref	Motorola Part No.	Description
C148	2113740F38	30pF
C149	2113743L41	0.01uF
C201	2113743L17	1000pF
C202	2113743N42	47pF
C203	2113743N34	18pF
C204	2113743L41	0.01uF
C205	2113743L41	0.01uF
C206	2113743N42	47pF
C214	2113741F49	0.1uF
C215	2113740L40	82pF
C216	2113740F38	30pF
C218	2113741F49	0.1uF
C219	2113741F49	0.1uF
C220	2113743N22	15pF
C221	2113741F49	0.1uF
C222	2113741F49	0.1uF
C223	2113743N19	5.1pF
C224	2113743N09	2pF
C225	2113743L41	0.1uF
C226	2113743N31	16pF
C227	2113741F49	0.1uF
C228	2113743N26	10pF
C229	2113743N48	82pF
C230	2113743N39	36pF
C231	2113743N44	56pF
C232	2113743A27	0.47uF
C233	2113743L41	0.01uF
C234	2113743A27	0.47uF
C235	2113932N44	56pF
C236	2113743N50	100pF
C237	2113743N12	2.7pF
C242	2113743N42	47pF
C247	2311049A56	4.7uF
C249	2113743L41	0.01uF
C255	2113741A61	0.047uF
C256	2113741A61	0.047uF
C257	2113741A61	0.047uF
C258	2311049F16	2.2uF
C259	2113743A27	0.47uF
C260	2113743F49	0.01uF
C261	2113741A27	0.47uF
C263	2311049A56	4.7uF
C280	2311049A09	2.2uF
C281	2104993J02	2.2uF
C283	2113743L41	0.01uF
C284	2113743L41	0.01uF
C285	2113743L41	0.01uF
C286	2113743L41	0.01uF
C287	2113743L41	0.01uF
C297	2113741F49	0.1uF
C298	2113743L41	0.01uF

Circuit Ref	Motorola Part No.	Description
C299	2311049A56	4.7uF
C301	2113743N30	15pF
C302	Not Placed	
C303	2113743R33	4700pF
C304	2113743R33	4700pF
C305	2113743R33	4700pF
C306	2113743N65	8pF
C307	2113743E20	0.1uF
C308	2180478Z20	1uF
C309	2113741F49	0.1uF
C310	2113743E20	0.1uF
C311	2113743N29	13pF
C312	2113743N29	13pF
C313	2113743N29	13pF
C314	2113743N29	13pF
C315	2113743N25	9.1pF
C316	2113743N30	15pF
C317	2311049A59	10uF
C319	2311049A59	10uF
C320	2113743A23	0.22uF
C321	2113743E07	0.022uF
C323	2113743E07	0.022uF
C324	2113743N50	100pF
C325	2113743A23	0.22uF
C326	2113743E20	0.1uF
C327	2113743R33	4700pF
C328	2113743E07	0.022uF
C330	2113743E20	0.1uF
C331	2113743E07	0.022uF
C332	2113743E20	0.1uF
C333	2109720D14	0.1uF
C334	2113740A82	1500pF
C335	2113743A23	0.22uF
C336	2311049A59	10uF
C337	2113743E07	0.022uF
C339	2113743F16	1uF
C340	2113743F16	1uF
C341	2113743F16	1uF
C342	2113743F16	1uF
C343	2113743A23	0.22uF
C348	2113743N09	2pF
C400	2113743L41	.01uF
C401	2113743M24	0.1uF
C402	2113743M24	0.1uF
C403	2113928D08	10uF
C404	Not Placed	
C405	Not Placed	
C406	Not Placed	
C407	2113928N01	0.1uF
C408	2113743N50	100pF
C409	2113743M24	0.1uF

Circuit Ref	Motorola Part No.	Description
C410	2113928N01	0.1uF
C411	2113743M24	0.1uF
C412	2311049A59	10uF
C414	2113743M24	0.1uF
C415	2109720D01	0.1uF
C416	2113928N01	0.1uF
C419	Not Placed	
C420	2113743L41	.01uF
C421	2113928N01	0.1uF
C422	2113743M24	0.1uF
C423	2113743N50	100pF
C424	2311049A59	10uF
C425	2113743M24	0.1uF
C426	2113743N50	100pF
C427	2113743N50	100pF
C428	2113743M24	0.1uF
C429	2113743M24	0.1uF
C430	2113928N01	0.1uF
C431	2113743N50	100pF
C432	Not Placed	
C433	2113743L41	.01uF
C434	2113743M24	0.1uF
C435	2113743M24	0.1uF
C436	2113743N34	22pF
C437	2113743N34	22pF
C438	2113743F18	2.2pF
C440	2113743F18	2.2pF
C441	2113743N50	100pF
C442	2113743E20	0.1uF
C443	2113928N01	0.1uF
C444	2113743N50	100pF
C445	2113743N50	100pF
C447	2113743M08	0.022uF
C448	2113928N01	0.1uF
C449	2113743N50	100pF
C450	Not Placed	
C451	2113743M08	0.022uF
C452	2113743G26	4.7uF
C453	2113743N50	100pF
C456	2113743N50	100pF
C458	2113743N50	100pF
C459	2113743N50	100pF
C463	2113743N50	100pF
C466	2113743N50	100pF
C467	2113928N01	0.1uF
C471	2113743N50	100pF
C472	2113743N50	100pF
C473	2113743N50	100pF
C475	2113743H14	10uF
C476	2113928D08	10uF
C479	2113928N01	0.1uF

Circuit Ref	Motorola Part No.	Description
C480	2113743G24	0.1uF
C481	2113928N01	0.1uF
C482	2113928N01	0.1uF
C490	2113743N50	100pF
C491	2113743N50	100pF
C492	2113743N50	100pF
C493	2113743N50	100pF
C494	2113743N50	100pF
C495	2113743N50	100pF
C496	2113743N50	100pF
C497	2113743N50	100pF
C500	2113743L41	0.01uF
C502	2311049A05	0.47uF
C503	2113743N50	100pF
C504	2113743N43	51pF
C505	2113743N50	100pF
C506	2113743N50	100pF
C507	2113743K15	0.1uF
C511	2113743N50	100pF
C512	2113743N50	100pF
C513	2113743N50	100pF
C514	2113743N50	100pF
C515	2113743N44	56pF
C516	2113928N37	30pF
C522	2113743L41	0.01uF
C533	2113743N40	100pF
C534	2113743N24	8.2pF
C535	2113743N09	2pF
C536	2113743N36	27pF
C537	2113743N16	3.9pF
C538	2113743N48	82pF
CR200	4880107R01	Varactor
CR201	4805648Q13	Dual Varactor
CR202	4805648Q13	Dual Varactor
CR203	4813833C07	Varactor
CR204	4813833C07	Varactor
CR211	4813833C03	Varactor
CR301	4813833C01	Varactor
CR411	4802245J62	Schottky Diode
CR412	4802245J62	Schottky Diode
CR413	4802245J62	Schottky Diode
CR440	4813833C02	Dual Diode Common Cathode
CR502	4880107R01	Rectifier
CR503	4805729G49	LED Red/Yellow
D100	4802482J02	Pin Diode
D101	4809948D23	Pin Diode
D102	4813825A21	Dual Diode
D103	4813825A21	Dual Diode
D104	Not Placed	
D210	4802233J09	Triple Diode
D211	4802233J09	Triple Diode

Circuit Ref	Motorola Part No.	Description
D501	4802245J42	Ring Quad Diode
D502	4805129M06	Dual Diode
E100	2480640R01	Ferrite Bead
E400	2480640Z01	Ferrite Bead
E401	2480640Z01	Ferrite Bead
E402	2480640Z01	Ferrite Bead
E403	2480640Z01	Ferrite Bead
E404	2480640Z01	Ferrite Bead
E405	2480640Z01	Ferrite Bead
E406	2480640Z01	Ferrite Bead
E407	2480640Z01	Ferrite Bead
E408	2480640Z01	Ferrite Bead
E409	2480640Z01	Ferrite Bead
F1	6580542Z01	Fuse 3A
FL301	4885631B01	109.65MHz Crystal Filter
FL401	4870368G02	38.4kHz Crystal Oscillator
J1	0986237A02	Connector
J101	0985613Z01	RF Jack
J102	0280519Z01	Antenna Nut
J400	0905505Y04	40-pins Connector
J403	0905505Y02	20-pins Connector
L100	2460591X13	125nH
L100*	2460591X12	110nH
L101	2460591X08	166nH
L101*	2460591X14	
L102	2460591X12	110nH
L102*	2460591X16	
L103	2462587T27	750nH
L104	2462587Q20	2.2uH
L105	2460591X13	125nH
L106	2460591X10	50nH
L106*	2460591X15	46nH
L107	2484562T03	8nH
L107*	2484562T20	5nH
L108	2462587Q08	220nH
L109	2462587Q08	220nH
L110	2460591X11	100nH
L200	2462587Q42	390nH
L201	2405452C63	1.35uH
L202	2405452C63	1.35uH
L203	2405452C63	1.35uH
L204	2462587T25	620nH
L207	2405452C27	4.7uH
L207*	2405452C63	1.35uH
L208	2462587T20	270nH
L208*	2462587T19	220nH
L209	2462587T20	270nH
L209*	2462587T19	220nH
L210	2405452C63	1.35uH
L211	2462587T21	330nH
L212	2462587T16	5.45nH

Circuit Ref	Motorola Part No.	Description
L215	2409348J04	13.85nH
L225	2462587L50	100uH
L226	2462587Q24	4.7uH
L301	2462587V35	120nH
L302	2462587T23	470nH
L303	2462587V38	220nH
L304	2462587T22	390nH
L305	2462587T22	390nH
L306	2462587T40	33nH
L307	2462587Q20	2.2uH
L308	2462587Q20	2.2uH
L400	2462587Q42	390nH
L401	2462587Q42	390nH
L410	2462587Q42	390nH
L411	2462587Q42	390nH
L501	2462587T17	150nH
L502	2462587T20	270nH
L503	2462587T30	1nH
L504	2462587T24	560nH
L507	2462587T17	150nH
L508	2462587V32	68nH
PB501	4080523Z01	Tactile, Push-button
PB502	4080523Z01	Tactile, Push-button
PB503	4080523Z01	Tactile, Push-button
PB504	4080523Z01	Tactile, Push-button
PB505	4080523Z01	Tactile, Push-button
Q100	4813828A08	FET
Q201	4802245J44	NPN
Q202	4805218N82	FET
Q203	4805218N82	FET
Q204	4805218N82	FET
Q288	4802245J44	NPN
Q301	4805218N63	NPN
Q400	4809579E18	MOSFET P-Channel
Q403	4880214G02	NPN
Q405	4802245J54	Dual NPN
Q410	4802245J54	Dual NPN
Q411	Not Placed	
Q416	4809579E18	MOSFET P-Chan
Q417	4802245J50	Dual NPN/PNP
Q509	4880214J44	NPN
Q510	4880214G02	NPN
R101	0662057A18	51
R102	0680735Z01	0.075
R103	0662057A25	100
R104	0662057M26	10
R105	0662057A32	200
R106	0662057A32	200
R107	0662057M66	470
R108	0662057M93	6.2K
R109	0662057M74	1K

Circuit Ref	Motorola Part No.	Description
R110	0662057M98	10K
R111	0662057N01	12K
R112	0662057M50	100
R113	0662057M50	100
R114	0662057N39	470K
R115	0662057M26	10
R116	0662057M81	2K
R117	0662057N47	1M
R118	0662057A01	10
R119	0662057A01	10
R120	0662057A25	100
R122	0662057M01	0
R203	0662057M50	100
R204	0662057M56	180
R206	0662057U45	56
R219	0662057N15	47K
R222	0662057N20	75K
R223	0662057N23	100K
R224	0662057M57	200
R225	0662057M67	510
R227	0662057M50	100
R228	0662057M43	51
R229	0662057M81	2K
R230	0662057M50	100
R231	0662057M46	68
R232	0662057N10	30K
R233	0662057M82	2.2K
R234	0662057A41	470
R235	0662057M72	820
R236	0662057M44	56
R237	0662057M16	3.9
R238	0662057M74	1K
R239	0662057M74	1K
R285	0662057M50	100
R286	0662057M01	0
R287	0662057N15	47K
R288	0662057M74	1K
R289	0662057M16	3.9
R301	0662057M78	1.5K
R302	0662057N15	47K
R303	0662057N15	47K
R304	0662057M78	1.5K
R305	0662057M98	10K
R306	0662057M77	1.3K
R307	0662057M92	5.6K
R308	0662057N01	12K
R309	0662057N22	91K
R310	0662057M87	3.6K
R312	0662057M78	1.5K
R314	0662057M98	10K
R315	0662057N15	47K

Circuit Ref	Motorola Part No.	Description
R316	0662057M57	200
R317	0662057M81	2K
R318	0662057M33	20
R400	0662057N15	47K
R401	0662057M01	0
R402	Not Placed	
R403	Not Placed	
R405	0662057M01	0
R406	0662057N20	75K
R407	0662057N19	68K
R408	Not Placed	
R409	0662057M98	10K
R410	0662057N23	100K
R411	0662057M98	10K
R413	0662057M01	0
R414	0662057V34	180K
R415	0662057V26	91K
R416	0662057N13	39K
R418	Not Placed	
R419	0662057M67	510
R420	0662057B46	10M
R421	0662057M81	2K
R423	0662057N21	82K
R424	0662057N12	36K
R425	0662057N10	30K
R426	0662057M35	330
R427	0662057M84	2.7K
R428	0662057M10	2.2
R429	0662057M98	10K
R431	0662057N39	470K
R432	0662057N16	51K
R434	0662057M62	330
R435	0662057M81	2K
R436	0662057M74	1K
R437	0662057M01	0
R445	0662057N08	24K
R446	0662057N30	220K
R447	0662057N52	1.6M
R448	0662057N33	270K
R449	0662057N08	24K
R450	0662057T45	68
R457	0662057M98	10K
R460	0662057M90	4.7K
R461	0662057M56	180
R462	0662057M98	10K
R463	0662057M61	300
R471	0662057M92	5.6K
R472	0662057M93	6.2K
R473	0662057M26	10
R475	0662057M01	0
R476	0662057N08	24K

Circuit Ref	Motorola Part No.	Description
R477	0662057M74	1K
R478	0662057M98	10K
R481	0662057N08	24K
R492	0662057M01	0
R499	Not Placed	
R501	0662057M70	680
R502	0662057M56	180
R503	0662057M74	1K
R504	0662057N01	12K
R505	0662057M68	10K
R507	0662057M60	270
R508	0662057M32	18
R509	0662057M60	270
R510	0662057M87	3.6K
R512	0662057M90	4.7K
R513	0662057M26	10
R514	0662057N15	47K
R515	0662057M98	10K
RT400	0680590Z01	Thermistor 33K
S501	4080710Z01	Channel Switch
S502	1880619Z01	Volume Switch
SH100	2686076A01	Shield
SH200	2685709B02	Shield
SH201	2680511Z01	Shield
SH202	2680511Z01	Shield
SH203	2686079A01	Shield
SH300	2680516Z01	Shield
SH301	2680508Z01	Shield
SH302	2680697Z01	Shield
SH303	2680553Z01	Shield
SH400	2680505Z01	Controller Memory Shield
SH401	2680506Z01	Controller On/Off Shield
SH402	2680515Z01	Controller Microprocessor Shield
SH403	2680516Z01	Controller ASFIC Cmp/Audi PA Shield
SH500	2680555Z01	Shield
SH501	2680697Z01	Shield
SH502	2680696Z01	Shield
T100	2505515V03	Transformer Coil
T501	2580541Z01	Transformer Coil
T502	2580541Z01	Transformer Coil
TR201	2460593D01	Resonator, 50-300MHz
U101	5105109Z67	LDMOS Driver
U102	5185765B01	Power Control
U200	5102463J58	3.3V Regulator
U203	4805649Q14	Varactor Diode
U204	5105739X05	Linear Regulator
U205	5185963A27	LV Fractional N Synthesizer
U207	4805921T06	Dual PNP
U301	4885622B01	Dual Gate MOSFET

Circuit Ref	Motorola Part No.	Description
U302	5185623B01	3.3V Regulator
U303	5109632D83	Low Voltage ZIF
U400	5102463J40	3.3V Regulator
U404	5185963A53	ASFIC
U405	Not Placed	
U406**	5102463J59	ROM 256K
U407**	5102463J64	EEPROM 16Kx8
U409	5102226J56	Microcontroller
U410	5102463J57	3.3V Regulator
U420	5102463J44	Audio PA
VR101	5185963A15	Temperature Sense
VR102	4802245J51	6.8V Zener
VR200	4802245J51	6.8V Zener
VR201	4802245J51	6.8V Zener
VR202	4802245J51	6.8V Zener
VR203	4802245J53	6.8V Zener
VR432	4805656W08	5.6V Zener
VR433	4805656W08	5.6V Zener
VR434	4802245J51	6.8V Zener
VR445	4802245J53	10V Zener
VR446	4802245J53	10V Zener
VR447	4802245J53	10V Zener
VR448	4802245J53	10V Zener
VR449	4802245J53	10V Zener
VR450	4802245J53	10V Zener
VR500	4800245J51	6.8V Zener
VR501	4813830A18	6.8V Zener
VR502	4802245J51	6.8V Zener
Y201	4805875Z03	Crystal Oscillator

** Motorola Depot Servicing only.

* Range 2 Only.