

LTE Radio Access, Rel. RL70, Operating Documentation, Issue 01

Flexi Zone Micro BTS Product Description

DN09158819

Issue 03

Approval Date 2014-11-17

The information in this document applies solely to the hardware/software product ("Product") specified herein, and only as specified herein.

This document is intended for use by Nokia Solutions and Networks' customers ("You") only, and it may not be used except for the purposes defined in the agreement between You and Nokia Solutions and Networks ("Agreement") under which this document is distributed. No part of this document may be used, copied, reproduced, modified or transmitted in any form or means without the prior written permission of Nokia Solutions and Networks. If you have not entered into an Agreement applicable to the Product, or if that Agreement has expired or has been terminated, You may not use this document in any manner and You are obliged to return it to Nokia Solutions and Networks and destroy or delete any copies thereof.

The document has been prepared to be used by professional and properly trained personnel, and You assume full responsibility when using it. Nokia Solutions and Networks welcome Your comments as part of the process of continuous development and improvement of the documentation.

This document and its contents are provided as a convenience to You. Any information or statements concerning the suitability, capacity, fitness for purpose or performance of the Product are given solely on an "as is" and "as available" basis in this document, and Nokia Solutions and Networks reserves the right to change any such information and statements without notice. Nokia Solutions and Networks has made all reasonable efforts to ensure that the content of this document is adequate and free of material errors and omissions, and Nokia Solutions and Networks will correct errors that You identify in this document. But, Nokia Solutions and Networks' total liability for any errors in the document is strictly limited to the correction of such error(s). Nokia Solutions and Networks does not warrant that the use of the software in the Product will be uninterrupted or error-free.

NO WARRANTY OF ANY KIND, EITHER EXPRESS OR IMPLIED, INCLUDING BUT NOT LIMITED TO ANY WARRANTY OF AVAILABILITY, ACCURACY, RELIABILITY, TITLE, NON-INFRINGEMENT, MERCHANTABILITY OR FITNESS FOR A PARTICULAR PURPOSE, IS MADE IN RELATION TO THE CONTENT OF THIS DOCUMENT. IN NO EVENT WILL NOKIA SOLUTIONS AND NETWORKS BE LIABLE FOR ANY DAMAGES, INCLUDING BUT NOT LIMITED TO SPECIAL, DIRECT, INDIRECT, INCIDENTAL OR CONSEQUENTIAL OR ANY LOSSES, SUCH AS BUT NOT LIMITED TO LOSS OF PROFIT, REVENUE, BUSINESS INTERRUPTION, BUSINESS OPPORTUNITY OR DATA THAT MAY ARISE FROM THE USE OF THIS DOCUMENT OR THE INFORMATION IN IT, EVEN IN THE CASE OF ERRORS IN OR OMISSIONS FROM THIS DOCUMENT OR ITS CONTENT.

This document is Nokia Solutions and Networks' proprietary and confidential information, which may not be distributed or disclosed to any third parties without the prior written consent of Nokia Solutions and Networks.

Nokia is a registered trademark of Nokia Corporation. Other product names mentioned in this document may be trademarks of their respective owners, and they are mentioned for identification purposes only.

Copyright © 2014 Nokia Solutions and Networks. All rights reserved.



Important Notice on Product Safety

This product may present safety risks due to laser, electricity, heat, and other sources of danger.

Only trained and qualified personnel may install, operate, maintain or otherwise handle this product and only after having carefully read the safety information applicable to this product.

The safety information is provided in the Safety Information section in the "Legal, Safety and Environmental Information" part of this document or documentation set.

Nokia Solutions and Networks is continually striving to reduce the adverse environmental effects of its products and services. We would like to encourage you as our customers and users to join us in working towards a cleaner, safer environment. Please recycle product packaging and follow the recommendations for power use and proper disposal of our products and their components.

If you should have questions regarding our Environmental Policy or any of the environmental services we offer, please contact us at Nokia Solutions and Networks for any additional information.

Table of Contents

This document has 35 pages

	Summary of changes.....	6
1	Introduction to Flexi Zone Micro BTS.....	7
2	Construction.....	12
2.1	Construction of Flexi Zone Micro BTS variants.....	13
2.2	Construction of directional antenna (FAWE).....	16
2.3	Construction of directional antenna (FAWF).....	16
2.4	Construction of directional antenna (FAWI).....	17
2.5	Construction of directional antenna (FAWJ).....	17
2.6	Construction of directional antenna (FAWK).....	17
2.7	Construction of omni antenna (FAWB).....	18
2.8	Construction of omni antenna (FAWC).....	18
2.9	Construction of omni antenna (FAWH).....	19
3	Air interface.....	20
4	Benefits.....	21
5	Transport and synchronization.....	22
6	Management and software.....	23
7	Interfaces.....	24
7.1	Interfaces of Flexi Zone Micro BTS (FWGB, FWHA, FWIB).....	24
7.2	Interfaces of Flexi Zone Micro BTS (FWFA, FWEA, FWHE, FWHF, FWHO, FWHN).....	25
7.3	Interfaces of Flexi Zone Micro BTS (FWHD).....	26
7.4	Interfaces of Flexi Zone Micro BTS (FWHC, FWHM).....	27
8	Safety for Public and Workers.....	28
8.1	Installing base stations to ensure public safety.....	28
8.2	Installing base stations to ensure installer safety.....	28
9	Flexi Zone Micro BTS (FWHA) CE Marking.....	30
10	Flexi Zone Micro BTS (FWIB, FWHD) United States FCC Part 15 compliance.....	31
11	Flexi Zone Micro BTS (FWIB, FWFA, FWHD) Industry Canada IC RSS-GEN compliance	32
12	Flexi Zone Micro Bluetooth Modular Approval	34
13	EU RoHS statement.....	35

List of Figures

Figure 1	Flexi Zone Micro BTS (FWGB, FWHA, FWIB).....	9
Figure 2	Flexi Zone Micro BTS (FWFA, FWEA, FWHE, FWHF, FWHO, FWHN). 9	
Figure 3	Flexi Zone Micro BTS (FWHC, FWHM).....	10
Figure 4	Flexi Zone Micro BTS (FWHD).....	11
Figure 5	Flexi Zone Micro BTS functional diagram (excluding FWHD).....	13
Figure 6	Flexi Zone Micro BTS (FWHD) functional diagram.....	13
Figure 7	Flexi Zone Micro BTS (FWGB, FWHA, FWIB) bottom view interfaces.. 24	
Figure 8	Flexi Zone Micro BTS (FWGB, FWHA, FWIB) top view interfaces....	24
Figure 9	Flexi Zone Micro BTS (FWGB, FWHA, FWIB) side view interfaces... 24	
Figure 10	Flexi Zone Micro BTS (FWFA, FWEA, FWHE, FWHF, FWHO, FWHN) bottom view interfaces.....	25
Figure 11	Flexi Zone Micro BTS (FWFA, FWEA, FWHE, FWHF, FWHO, FWHN) top view interfaces.....	25
Figure 12	Flexi Zone Micro BTS (FWFA, FWEA, FWHE, FWHF, FWHO, FWHN) side view interfaces.....	25
Figure 13	Flexi Zone Micro BTS (FWHD) bottom view interfaces.....	26
Figure 14	Flexi Zone Micro BTS (FWHD) top view interfaces.....	26
Figure 15	Flexi Zone Micro BTS (FWHD) side view interfaces.....	26
Figure 16	Flexi Zone Micro BTS (FWHC, FWHM) bottom view interfaces.....	27
Figure 17	Flexi Zone Micro BTS (FWHC, FWHM) top view interfaces.....	27
Figure 18	Flexi Zone Micro BTS (FWHC, FWHM) side view interfaces.....	27
Figure 19	CE marking.....	30

List of Tables

Table 1	Flexi Zone Micro BTS naming convention.....	8
Table 2	Construction of Flexi Zone Micro BTS (FDD-LTE variants)	14
Table 3	Construction of Flexi Zone Micro BTS (TDD-LTE variants)	16
Table 4	Properties of directional antenna (FAWE) (473029A).....	16
Table 5	Properties of directional antenna (FAWF) (473030A).....	16
Table 6	Properties of directional antenna (FAWI) (473172A).....	17
Table 7	Properties of directional antenna (FAWJ) (473173A).....	17
Table 8	Properties of directional antenna (FAWK) (473174A).....	17
Table 9	Properties of omni antenna (FAWB) (472933A).....	18
Table 10	Properties of omni antenna (FAWC) (472947A).....	18
Table 11	Properties of omni antenna (FAWH) (473171A).....	19
Table 12	Required Compliance Boundaries (CB) by band (all single carrier FZM variants).....	28
Table 13	Required Compliance Boundaries (CB) by band (all three carrier FZM variants).....	29

Summary of changes

Changes between document issues are cumulative. Therefore, the latest document issue contains all changes made to previous issues.

This document describes all variants of Flexi Zone Micro BTS. The differences between the variants are indicated in the respective chapters.

Changes between issues 02 (2014-10-30) and 03 (2014-11-17)

Information on the following variants has been added:

- Flexi Zone Micro BTS (FWHM) 2600 MHz FDD-LTE
- Flexi Zone Micro BTS (FWHO) 2600 MHz FDD-LTE
- Flexi Zone Micro BTS (FWHN) 2600 MHz FDD-LTE

Changes between issues 01A (2014-07-17) and 02 (2014-10-30)

Information on the following variants has been added:

- Flexi Zone Micro BTS (FWFA) 1900 MHz FDD-LTE
- Flexi Zone Micro BTS (FWEA) 1800 MHz FDD-LTE
- Flexi Zone Micro BTS (FWHC) 2600 MHz FDD-LTE
- Flexi Zone Micro BTS (FWHD) 2600 MHz TDD-LTE
- Flexi Zone Micro BTS (FWHE) 2600 MHz TDD-LTE
- Flexi Zone Micro BTS (FWHF) 2600 MHz TDD-LTE

Changes between issues 01 (2014-02-10) and 01A (2014-07-17)

Chapter *FCC Part 15 compliance* removed.

Flexi Zone Micro BTS (FWIB) Industry Canada IC RSS-GEN compliance

- New chapter.

Flexi Zone Micro BTS (FWHA) CE Marking

- New chapter.

Supported bandwidth

- Table with Flexi Zone Micro BTS supported bandwidth variants added.

Flexi Zone Micro BTS (FWIB) United States FCC Part 15 compliance

- New chapter.

Flexi Zone Micro Bluetooth Modular Approval

- New chapter.

1 Introduction to Flexi Zone Micro BTS

The Flexi Zone Micro BTS is a second generation small cell BTS optimized for outdoor micro-cell environment. The product design utilizes a small cell specific radio architecture based on a radio frequency integrated circuit device, and an integrated baseband processing solution that enables feature parity with the Flexi Macro BTS solutions.

The main application of this BTS, is to help deliver an improved mobile broadband experience by enhancing coverage and capacity both outdoor and indoor. Thanks to its small size and fanless solution the BTS can be used in micro cell applications. It can be deployed at street level and on rooftops in order to cover traffic hotspots or to fill network coverage holes as well as improve coverage inside buildings, for example at airports and railway stations.

The Flexi Zone Micro BTS provides functionality defined by 3GPP for an eNodeB and supports standard network interfaces to other network elements, that is S1 and X2.

The performance of the product is defined in a way that the air-interface is the only thing which limits the throughput for the LTE implementation. The HW platform supports full throughput capability of 20 MHz LTE FDD carriers with 2x2 MIMO and two 20 MHz carriers for the TDD hardware variant (three 20 MHz carriers in case of FWHD). The physical transport interface is optimized for IP-based transport solutions. Furthermore, the BTS supports varying transmit power.



TDD-LTE multi-carrier mode depends on the SW release.

Flexi Zone Micro BTS is available in the following variants:

- Flexi Zone Micro BTS (FWGB) 2100 MHz FDD-LTE
- Flexi Zone Micro BTS (FWHA) 2600 MHz FDD-LTE
- Flexi Zone Micro BTS (FWIB) 2100 MHz AWS FDD-LTE
- Flexi Zone Micro BTS (FWFA) 1900 MHz FDD-LTE
- Flexi Zone Micro BTS (FWEA) 1800 MHz FDD-LTE
- Flexi Zone Micro BTS (FWHC) 2600 MHz FDD-LTE
- Flexi Zone Micro BTS (FWHM) 2600 MHz FDD-LTE
- Flexi Zone Micro BTS (FWHO) 2600 MHz FDD-LTE
- Flexi Zone Micro BTS (FWHN) 2600 MHz FDD-LTE
- Flexi Zone Micro BTS (FWHD) 2600 MHz TDD-LTE
- Flexi Zone Micro BTS (FWHE) 2600 MHz TDD-LTE
- Flexi Zone Micro BTS (FWHF) 2600 MHz TDD-LTE

Flexi Zone Micro BTS naming convention

The Flexi BTS family is named according to the following format - Fxxx. [Table 1: Flexi Zone Micro BTS naming convention](#) shows the explanation of the format.



[Table 1: Flexi Zone Micro BTS naming convention](#) might not list all the possible variants/items. Additionally, some items might not be available in certain releases.

Table 1 Flexi Zone Micro BTS naming convention

Letter	Description
F _ _ _	Flexi family
_ A _ _	Flexi Zone Micro BTS antenna variant The general naming is FAWx. It indicates an integrated antenna (omni or directional). It can also be a GPS antenna.
_ M _ _	Flexi Zone Micro BTS mounting bracket The general naming is FMWx, where x indicates: <ul style="list-style-type: none"> A - wall and pole mounting bracket B - directional antenna tilt bracket
_ O _ _	Flexi Zone Micro BTS SFP The general naming is FOSx, where x indicates: <ul style="list-style-type: none"> D - optical SFP 1000Base-SX 850 nm MM C - optical SFP 1000Base-LX 1310 nm SM
_ P _ _	Flexi Zone Micro BTS AC power cable The general naming is FPWx.
_ W _ _	Flexi Zone Micro BTS variant The general naming is FWxy, where x indicates: <ul style="list-style-type: none"> E - 1800 MHz (FDD-LTE band 3) F - 1900 MHz (FDD-LTE band 2/25) G - 2100 MHz (FDD-LTE band 1) H - 2600 MHz (FDD-LTE band 7, TDD-LTE band 41) I - 2100 MHz (AWS) (FDD-LTE band 4) N - 2300 MHz (TDD-LTE band 40)
_ _ x _	Application, usage, or frequency band.
_ _ _ x	Used for additional product identification as required.

Figure 1 Flexi Zone Micro BTS (FWGB, FWHA, FWIB)



Figure 2 Flexi Zone Micro BTS (FWFA, FWEA, FWHE, FWHF, FWHO, FWHN)



Figure 3 Flexi Zone Micro BTS (FWHC, FWHM)



Figure 4 Flexi Zone Micro BTS (FWHD)



2 Construction

All Flexi Zone Micro BTS variants are outdoor-capable and weather-sealed. Flexi Zone Micro BTS consists of the following elements:

- **Core base station module**
The core mechanics, with installed gaskets in all of the connectors, shields the module core against water, snow, and solid foreign objects, and make the module core IP65 weatherproof. The core mechanics also provide EMC shielding. The core module integrates the following items into one single unit:

- RF
- baseband functionality
- clock and control
- external interfaces
- transmission

Some variants also contain an integrated Wi-Fi antenna which makes Flexi Zone Micro BTS a wireless Access Point (AP).

- **Bluetooth antenna**
The Bluetooth antenna is used to manage Flexi Zone Micro BTS locally with a PC.
- **Optional GPS antenna**
The GPS signal can be used as a synchronization source. GPS antenna FAWD (472932A) can be used with any Flexi Zone Micro BTS variant. GPS/GLONASS antenna FAWG (473100A) can be used with the variants that support Wi-Fi.
- **Optional integrated antenna (omni or directional)**
The BTS has a directional antenna panel that is field-installable. It is mounted to the front of the Flexi Zone Micro BTS as an alternative to the integrated omni antennas. When the directional antenna is not used, the BTS can be configured with omni antennas connected directly to the RF antenna ports, or connected to remotely located external antennas via RF cables. An integrated antenna is an optional item with protection class IP65.
- **Optional external antenna**
An external antenna is an optional item used when an integrated antenna is not connected.



Remotely located antennas must meet the requirements outlined by the antenna installation section in the installation manual and be equipped with additional in-line surge protection.

- **Module cables, accessories**
All cables are in protection class IP65. Accessories include, for example, mounting bracket, ground lug, cable strain reliefs, environmental grommets.

The functional diagram of the BTS is shown in [Figure 5: Flexi Zone Micro BTS functional diagram \(excluding FWHD\)](#) and [Figure 6: Flexi Zone Micro BTS \(FWHD\) functional diagram](#).

Figure 5 Flexi Zone Micro BTS functional diagram (excluding FWHD)

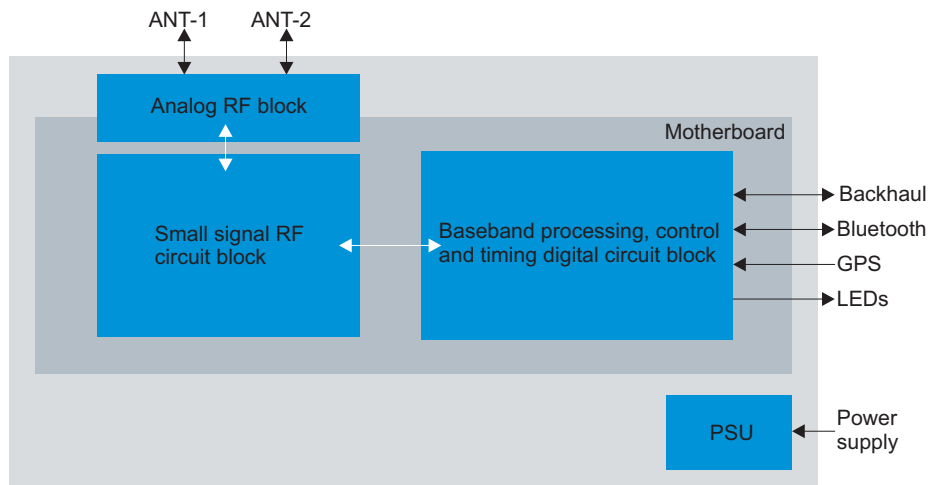
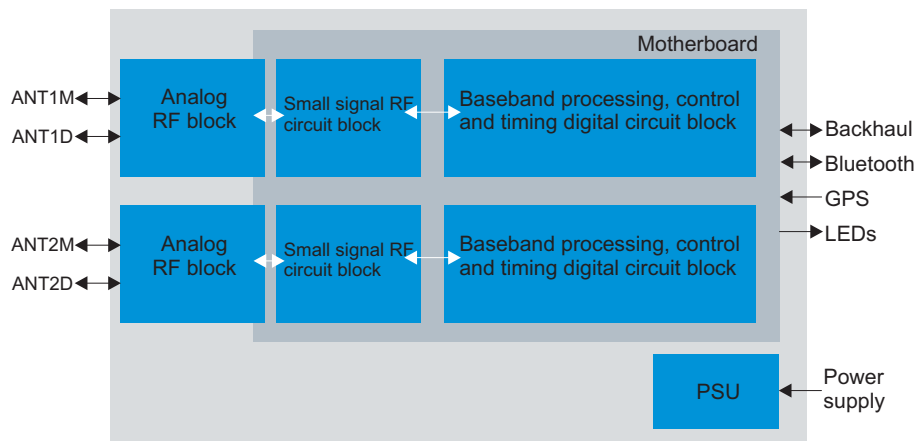

Figure 6 Flexi Zone Micro BTS (FWHD) functional diagram



2.1 Construction of Flexi Zone Micro BTS variants

Table 2: Construction of Flexi Zone Micro BTS (FDD-LTE variants) and Table 3: Construction of Flexi Zone Micro BTS (TDD-LTE variants) show the HW characteristic of the available Flexi Zone Micro BTS variants.

Variant	Shows the variant name, feature id, and sales code. For the explanation of the abbreviation, see Table 1: Flexi Zone Micro BTS naming convention .
Dimensions	Shows the height, width, depth, weight, and volume of the variant.
Band	Shows the band, exact frequency range, supported bandwidths, and number of supported carriers.
Power	Shows the maximum output power at the antenna connector and range of the configurable power levels.
Integrated antenna	Shows which integrated antenna variant (omni, directional) is supported.
Integrated Wi-Fi	Shows whether the variant contains an integrated Wi-Fi.

Table 2 Construction of Flexi Zone Micro BTS (FDD-LTE variants)

Variant	Dimensions	Band	Power	Integrated antenna	Integrated Wi-Fi
FWGB LTE1659 472851A	H: 247 mm (9.72 in.) W: 327 mm (12.87 in.) D: 86 mm (3.38 in.) W: 5.2 kg (11.46 lb) V: 5 l	Band 1 UL: 1920 - 1980 MHz DL: 2110 - 2170 MHz Bandwidths: 5, 10, 15, 20 MHz Carriers: 1	2 x 5 W 0.25, 0.315, 0.4, 0.5, 0.63, 0.8, 1, 1.2, 1.6, 2, 2.5, 3, 4, 5 W	Directional: FAWE Omni: FAWB	No
FWHA LTE1682 472897A	W: 327 mm (12.87 in.) H: 247 mm (9.72 in.) D: 86 mm (3.38 in.) W: 5.2 kg (11.46 lb) V: 5 l	Band 7 UL: 2500 - 2570 MHz DL: 2620 - 2690 MHz Bandwidths: 5, 10, 15, 20 MHz Carriers: 1	2 x 5 W 0.25, 0.315, 0.4, 0.5, 0.63, 0.8, 1, 1.2, 1.6, 2, 2.5, 3, 4, 5 W	Directional: FAWF Omni: FAWC	No
FWIB LTE1727 472899A	W: 327 mm (12.87 in.) H: 247 mm (9.72 in.) D: 86 mm (3.38 in.) W: 5.2 kg (11.46 lb) V: 5 l	Band 4 UL: 1710 - 1755 MHz DL: 2110 - 2155 MHz Bandwidths: 5, 10, 15, 20 MHz Carriers: 1	2 x 5 W 0.25, 0.315, 0.4, 0.5, 0.63, 0.8, 1, 1.2, 1.6, 2, 2.5, 3, 4, 5 W	Directional: FAWE Omni: FAWB	No
FWFA LTE2055 473040A	W: 327 mm (12.87 in.) H: 247 mm (9.72 in.) D: 120 mm (4.72 in.) W: 8.0 kg (17.63 lb) V: 7.2 l	Band 2 and 25 UL: 1850 - 1915 MHz DL: 1930 - 1995 MHz Bandwidths: 5, 10, 15, and 20 MHz Carriers: 1	2 x 5 W 0.25, 0.315, 0.4, 0.5, 0.63, 0.8, 1, 1.2, 1.6, 2, 2.5, 3, 4, 5 W	Directional: FAWI Omni: FAWB	No
FWEA LTE1728 472898A	W: 327 mm (12.87 in.) H: 247 mm (9.72 in.) D: 120 mm (4.72 in.) W: 6.2 kg (13.66 lb) V: 7.2	Band: 3 UL: 1710 - 1785 MHz DL: 1805 - 1880 MHz	2 x 5 W 0.25, 0.315, 0.4, 0.5, 0.63, 0.8, 1, 1.2, 1.6, 2, 2.5, 3, 4, 5 W	Directional: FAWI Omni: FAWB	No

Table 2 Construction of Flexi Zone Micro BTS (FDD-LTE variants) (Cont.)

Variant	Dimensions	Band	Power	Integrated antenna	Integrated Wi-Fi
		Bandwidths: 5, 10, 15, and 20 MHz Carriers: 1			
FWHC LTE1961 472938A	W: 327 mm (12.87 in.) H: 247 mm (9.72 in.) D: 120 mm (4.72 in.) W: 7.2 kg (15.87 lb) V: 7.2 l	Band: 7 (low band) UL: 2500 - 2555 MHz DL: 2620 - 2675 MHz Bandwidths: 5, 10, 15, and 20 MHz. Carriers: 1	2 x 5 W 0.25 , 0.315, 0.4, 0.5, 0.63, 0.8, 1, 1.2, 1.6, 2, 2.5, 3, 4, 5 W	Directional: FAWK Omni: FAWC	Directional: FAWK Omni: FAWH
FWHM LTE2340 473147A	W: 327 mm (12.87 in.) H: 247 mm (9.72 in.) D: 120 mm (4.72 in.) W: 7.2 kg (15.87 lb) V: 7.2 l	Band: 7 (high band) UL: 2520 - 2570 MHz DL: 2640 - 2690 MHz Bandwidths: 5, 10, 15, 20 Carriers: 1	2 x 5 W 0.25 , 0.315, 0.4, 0.5, 0.63, 0.8, 1, 1.2, 1.6, 2, 2.5, 3, 4, 5 W	Directional: FAWK Omni: FAWC	Directional: FAWK Omni: FAWH
FWHO LTE2338 473149A	W: 327 mm (12.87 in.) H: 247 mm (9.72 in.) D: 120 mm (4.72 in.) W: 6.2 kg (13.67 lb) V: 7.2 l	Band: 7 (low band) UL: 2500 -2555 MHz DL: 2620 -2675 MHz Bandwidths: 5, 10, 15, 20 MHz Carriers: 1	2 x 5 W 0.25 , 0.315, 0.4, 0.5, 0.63, 0.8, 1, 1.2, 1.6, 2, 2.5, 3, 4, 5 W	Directional: FAWJ Omni: FAWC	No
FWHN LTE2339 473148A	W: 327 mm (12.87 in.) H: 247 mm (9.72 in.) D: 120 mm (4.72 in.) W: 6.2 kg (13.67 lb) V: 7.2 l	Band: 7 (high band) UL: 2520 - 2570 MHz DL: 2640 - 2690 MHz Bandwidths: 5, 10, 15, 20 Carriers: 1	2 x 5 W 0.25 , 0.315, 0.4, 0.5, 0.63, 0.8, 1, 1.2, 1.6, 2, 2.5, 3, 4, 5 W	Directional: FAWJ Omni: FAWC	No

Table 3 Construction of Flexi Zone Micro BTS (TDD-LTE variants)

Variant	Dimensions	Band	Power	Integrated antenna	Integrated Wi-Fi
FWHD LTE1889 472852A	H: 482 mm (18.97 in.) W: 335 mm (13. 8 in.) D: 86 mm (3.38 in.) W: 12.6 kg (27.78 lb) V: 12 l	Band 41 2496 - 2690 MHz Bandwidths: 10, 20 MHz Carriers: 3	4 x 5 W 0.25, 0.315, 0.4, 0.5, 0.63, 0.8, 1, 1.2, 1.6, 2, 2.5, 3, 4, 5 W	Omni: FAWC	No
FWHE LTE1729 472939A	W: 327 mm (12.87 in.) H: 247 mm (9.72 in.) D: 120 mm (4.72 in.) W: 6.2 kg (13.66 lb) V: 7.2 l	Band 41 2575 - 2635 MHz Bandwidths: 10, 20 MHz Carriers: 1	2 x 5 W 0.25, 0.315, 0.4, 0.5, 0.63, 0.8, 1, 1.2, 1.6, 2, 2.5, 3, 4, 5 W	Directional: FAWJ Omni: FAWC	No
FWHF LTE1964 472940A	W: 327 mm (12.87 in.) H: 247 mm (9.72 in.) D: 120 mm (4.72 in.) W: 6.2 kg (13.66 lb) V: 7.2 l	Band 41 2545 - 2575 MHz Bandwidths: 10, 20 MHz Carriers: 1	2 x 4 W 0.25, 0.315, 0.4, 0.5, 0.63, 0.8, 1, 1.2, 1.6, 2, 2.5, 3, 4 W	Directional: FAWJ Omni: FAWC	No

2.2 Construction of directional antenna (FAWE)

Table 4 Properties of directional antenna (FAWE) (473029A)

Property	Value
Frequency range	1710 - 2170 MHz
Antenna gain	~7 dBi
Antenna beam-widths	horizontal: 70° vertical: 60°
Antenna configuration	2TX/2RX MIMO with 2 antennas
Antenna ports (mounting)	N-type

2.3 Construction of directional antenna (FAWF)

Table 5 Properties of directional antenna (FAWF) (473030A)

Property	Value
Frequency range	2400 – 2700 MHz
Antenna gain	~8 dBi

Table 5 Properties of directional antenna (FAWF) (473030A) (Cont.)

Property	Value
Antenna beam-widths	horizontal: 70° vertical: 60°
Antenna configuration	2TX/2RX MIMO with 2 antennas
Antenna ports (mounting)	N-type

2.4 Construction of directional antenna (FAWI)

Table 6 Properties of directional antenna (FAWI) (473172A)

Property	Value
Frequency range	1710 - 2170 MHz
Antenna gain	~7 dBi
Antenna beam-widths	horizontal: 70° vertical: 60°
Antenna configuration	2TX/2RX MIMO with 2 antennas
Antenna ports (mounting)	N-type

2.5 Construction of directional antenna (FAWJ)

Table 7 Properties of directional antenna (FAWJ) (473173A)

Property	Value
Frequency range	2400 - 2700 MHz
Antenna gain	~8 dBi
Antenna beam-widths	horizontal: 70° vertical: 60°
Antenna configuration	2TX/2RX MIMO with 2 antennas
Antenna ports (mounting)	N-type

2.6 Construction of directional antenna (FAWK)

Table 8 Properties of directional antenna (FAWK) (473174A)

Property	Value
Frequency range	LTE band 7 (2400 - 2700 MHz) with dual-band Wi-Fi (2400 – 5925 MHz)
Antenna gain	~6 dBi

Table 8 Properties of directional antenna (FAWK) (473174A) (Cont.)

Property	Value
Antenna beam-widths	horizontal: 70° vertical: 60°
Antenna configuration	2TX/2RX MIMO
Antenna ports (mounting)	N-type

2.7 Construction of omni antenna (FAWB)

Table 9 Properties of omni antenna (FAWB) (472933A)

Property	Value
Frequency range	698-960/1710-2170 MHz
Antenna gain	~1 dBi
Antenna beam-widths	horizontal: 360° vertical: 50°
Antenna configuration	2TX/2RX MIMO with 2 antennas
Antenna ports (mounting)	N-type
Height	129 mm (5.07 in.)
Width	22.8 mm (0.89 in.)
Weight	0.14 kg (0.31 lb)

2.8 Construction of omni antenna (FAWC)

Table 10 Properties of omni antenna (FAWC) (472947A)

Property	Value
Frequency range	2400 – 2700 MHz (band 7, 38, 41)
Antenna gain	~2 dBi
Antenna beam-widths	horizontal: 360° vertical: 50°
Antenna configuration	2TX/2RX MIMO with 2 antennas
Antenna ports (mounting)	N-type
Height	129 mm (5.07 in.)
Width	22.8 mm (0.89)
Weight	0.14 kg (0.31 lb)

2.9 Construction of omni antenna (FAWH)

Table 11 Properties of omni antenna (FAWH) (473171A)

Property	Value
Frequency range	LTE band 7 (2400 - 2700 MHz) with dual-band Wi-Fi (2400 – 5925 MHz)

3 Air interface

The BTS transceiver is equipped with TX/RX antenna connections. Each transmit port supports a maximum of several watts transmit power. Receivers support reference sensitivity specifications as defined in 3GPP 36.104 for Medium Area base stations. In addition to 3GPP standards alignment with the Flexi Multi Radio BTS, Flexi Zone Micro BTS follows Medium Area BTS specifications from TS 36.104 Rel-11. Carrier frequency can be freely selected via SW within frequency associated with the band specific hardware variant.

FDD-LTE

Flexi Zone Micro BTS FDD-LTE variants support full throughput capability of one 20 MHz LTE carrier with 2x2 MIMO.

TDD-LTE

In TDD-LTE variants the air interface can be configured for a two-carrier operation and can be configured with any combination of bandwidths, provided that carriers occupy contiguous frequencies, and operate within the maximum bandwidth window of 40 MHz for TDD.



SW support for two-carrier operation in FWHE and FWHF will be introduced in the future SW release.

FWHD supports three-carrier operation.

When multiple carriers are configured to use a single radio module, each carrier must share the transmit power (for example, 37 dBm per TX is shared across all carriers). All carriers sharing a single radio module must be configured with the same transmit power level ensuring the power level of each carrier is equal to, or less than, the full capability of the radio module (for example, 5 W).

Diversity

Flexi Zone Micro BTS supports two-way receiver diversity. Each carrier can be configured for normal operation with 2TX/2RX, 1TX/2RX, or 1TX/1RX within the same radio module.

4 Benefits

Flexi Zone Micro BTS provides a vast number of benefits for the operator.

Easy installation

Flexi Zone Micro BTS offers new site deployment possibilities thanks to its compact size and light weight which makes it easy and fast to deploy. Its compact size enables minimum installation clearance which allows Flexi Zone Micro BTS to be installed in areas of limited space like crowded sites, utility rooms, or inside the cabinets. This small base station can be also installed back to back at compact multiband and multiradio sites. The portability enables further savings in the form of lower rental costs and simpler site acquisition due to the unit requiring less space. As a result of this, operators are now able to extend their coverage to areas that were previously inaccessible. As the Flexi Zone Micro BTS is deployable by a single person and consumes little power, installation and running costs are significantly reduced without compromising the quality of the delivery capacity.

The size of the BTS makes it unnoticeable in locations such as exterior walls, billboards, lamp-posts, and bus stops.

Low acoustic noise

Flexi Zone Micro BTS uses passive cooling.

Easy commissioning

Flexi Zone Micro BTS supports wizard-based commissioning via the BTS Site Manager. The configuration can be saved to a file which can be later reused as a template.

Auto-connection and auto configuration support is also available for Flexi Multiradio BTS and Flexi Multiradio 10 BTS.

Software features

Flexi Zone Micro BTS enables feature parity with the Flexi Macro BTS solutions. For the full list of features and their descriptions, see *Feature List*.

5 Transport and synchronization

Flexi Zone Micro BTS uses IP/Ethernet as a standard transport protocol. Ethernet, both copper and fiber, is the standard interface used by the BTS. When external transport solutions (such as wireless backhaul) are used, they interface through the Ethernet connections on the BTS and the technology used is transparent to the BTS.

Passive optical networks (PONs) can be supported via E-PON or G-PON SFPs. An IOT with the PON vendor will be required to use customer-specific PON SFPs.

Flexi Zone Micro supports the following LTE network interfaces:

- eNodeB to MME and Serving SAE Gateway with S1 interface
- eNodeB to eNodeB with X2 interface

The physical transport interface configuration available is RJ45 + SFP (fiber).

Copper Ethernet

Flexi Zone Micro BTS Base Module RJ45 socket supports 1 Gigabit Ethernet copper interface 100/1000 Base-T according IEEE802.3 clause 40.

Fiber Ethernet

Flexi Zone Micro BTS supports single-mode and multi-mode fibers. The 1 Gigabit Ethernet SFP interface is based on MSA INF-8074. The following fiber SFP module options are available:

- 1000BASE-SX up to 550 m (FOSD)
- 1000BASE-LX up to 10 km (FOOSC)

Synchronization

Flexi Zone Micro BTS supports the following synchronization mechanisms:

- Integrated GPS/GNSS
- Synchronous Ethernet (ITU-T G.8261) (only FDD-LTE variants)
- Timing over Packet according to IEEE 1588v2

BTS chaining

Flexi Zone Micro BTS supports the ability to connect additional BTS sites that are downstream from the network interface terminations (S1, X2). Deployment configurations include co-located BTSs to provide multiple sector or multiple band developments at a single shared installation point. In addition, one site is also used as an intermediate transport termination point for a geographically separated site. Note that downstream BTSs have to use satellite-based synchronization.

6 Management and software

The Flexi Zone Micro BTS can be managed locally through the RJ45 port or through a Bluetooth connection. This eliminates the need for a wired connection to the Flexi Zone Micro BTS when it is installed in a difficult to reach location. NetAct can also be used to manage the Flexi Zone Micro BTS remotely.

Flexi Zone Micro BTS features an internal Bluetooth module which consists of an on-board Bluetooth transceiver. The transceiver provides a 78 channel EDR 2.1 compliant Bluetooth interface used for remote MMI and maintenance operations. All required SW is loaded and installed onto the Flexi Zone Micro BTS Bluetooth Module as part of the overall Flexi Zone Micro BTS product software. Contact Nokia Solutions and Networks for additional details.

The BTS automatically detects the SW version number, HW product code, version number and serial number during the start-up. This data can be retrieved remotely. The BTS supervises its internal operation, ensuring that any malfunctions or loss-of-service is detected and reported to the network management.

Software updates

New SW versions can be downloaded while the BTS is in operation. The software can be uploaded to BTS either locally, with the BTS Site Manager, or remotely from NetAct. Site visits are therefore unnecessary for routine operation and maintenance (O&M) tasks.

Typically, a local software download is done only when the NetAct connection is missing, for example, during the commissioning process. Software downloads can be run in the background of the BTS operation. The new software can be activated at any time. A reboot is required in order to activate the software.

The BTS only uses downloadable software. All software can be downloaded and updated from NetAct. This procedure is centralized. As the procedure is centralized, upgrading SW for several BTSs can be performed simultaneously or individually.

The BTS keeps the current and previous software packages in its flash memory and can be updated at any moment. Updated software (current and previous) in the BTS can be seen through BTS Site Manager/NetAct.

7 Interfaces

7.1 Interfaces of Flexi Zone Micro BTS (FWGB, FWHA, FWIB)

Figure 7 Flexi Zone Micro BTS (FWGB, FWHA, FWIB) bottom view interfaces

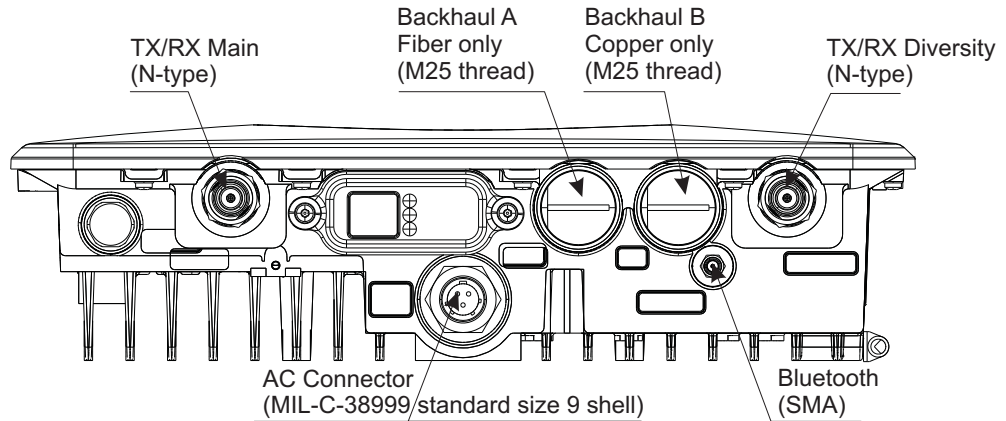
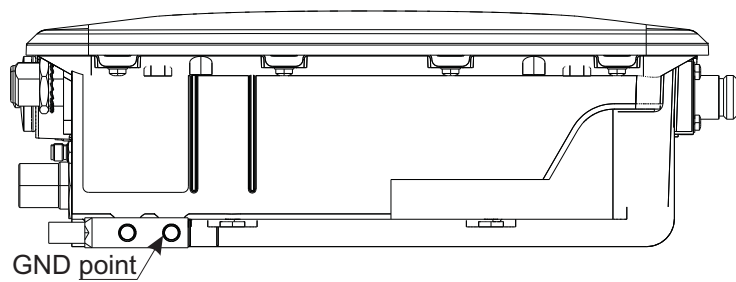

Figure 8 Flexi Zone Micro BTS (FWGB, FWHA, FWIB) top view interfaces

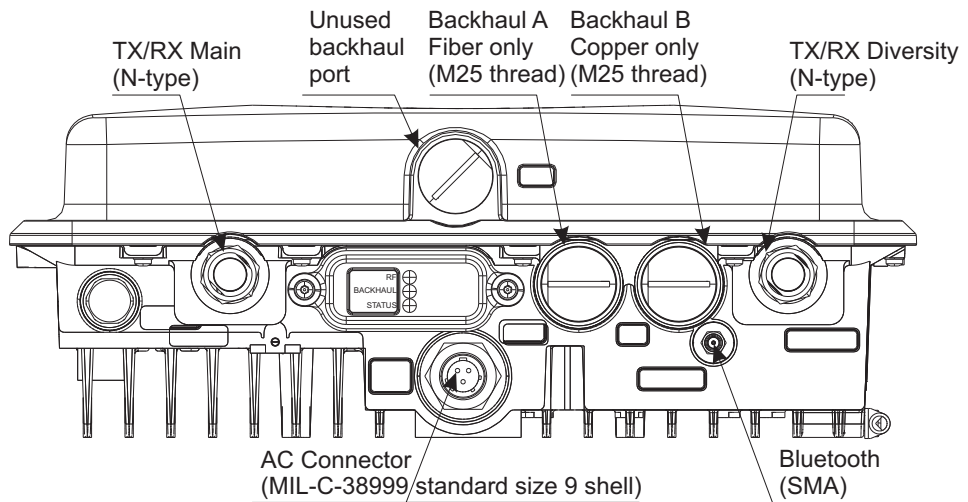

Figure 9 Flexi Zone Micro BTS (FWGB, FWHA, FWIB) side view interfaces



7.2 Interfaces of Flexi Zone Micro BTS (FWFA, FWEA, FWHE, FWHF, **FWHO**, FWHN)

Figure 10 Flexi Zone Micro BTS (FWFA, FWEA, FWHE, FWHF, FWHO, FWHN) bottom view interfaces



In case of FWHE and FWHF both backhaul interfaces are optical.

Figure 11 Flexi Zone Micro BTS (FWFA, FWEA, FWHE, FWHF, FWHO, FWHN) top view interfaces

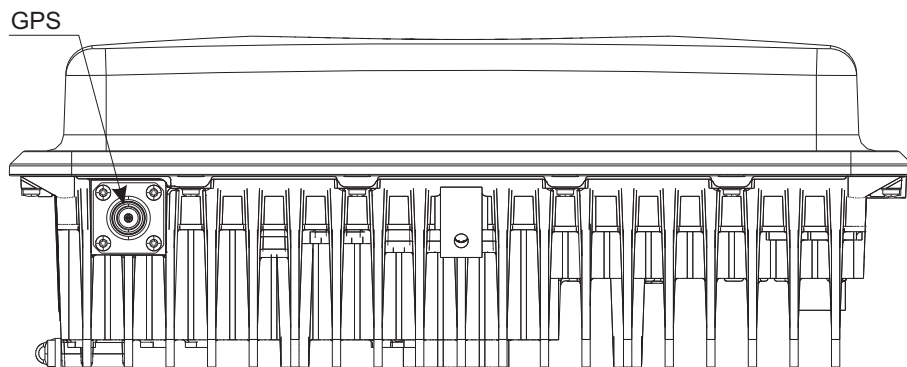
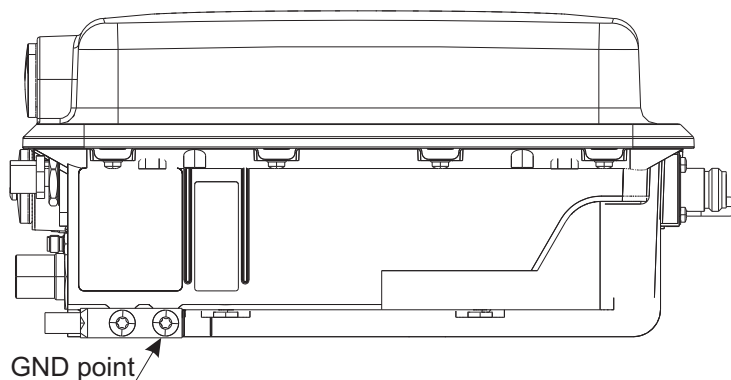

Figure 12 Flexi Zone Micro BTS (FWFA, FWEA, FWHE, FWHF, FWHO, FWHN) side view interfaces



7.3 Interfaces of Flexi Zone Micro BTS (FWHD)

Figure 13 Flexi Zone Micro BTS (FWHD) bottom view interfaces

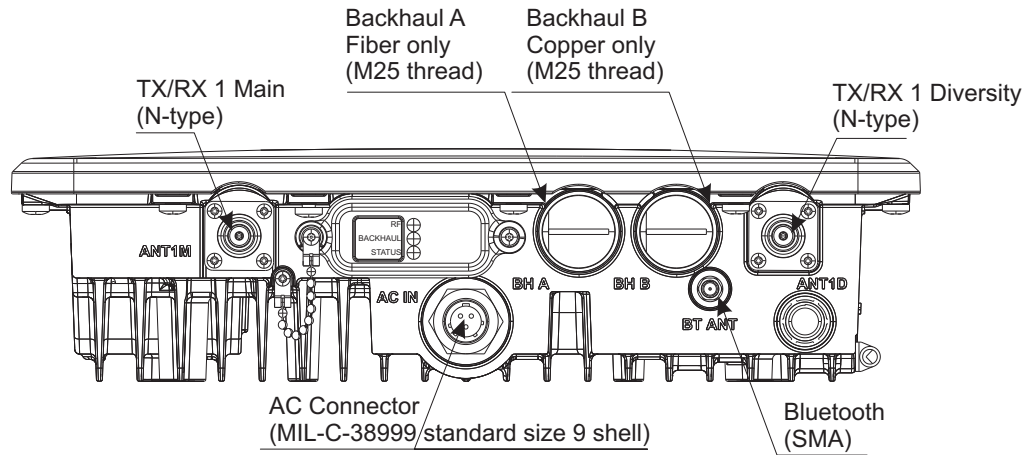

Figure 14 Flexi Zone Micro BTS (FWHD) top view interfaces

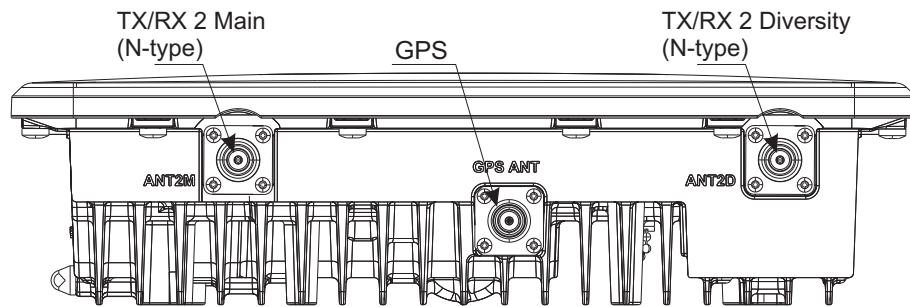
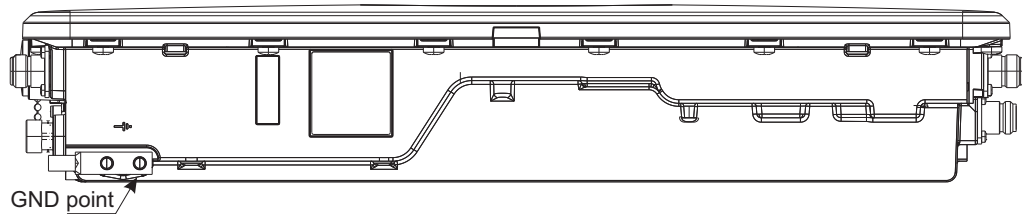

Figure 15 Flexi Zone Micro BTS (FWHD) side view interfaces



7.4 Interfaces of Flexi Zone Micro BTS (FWHC, FWHM)

Figure 16 Flexi Zone Micro BTS (FWHC, FWHM) bottom view interfaces

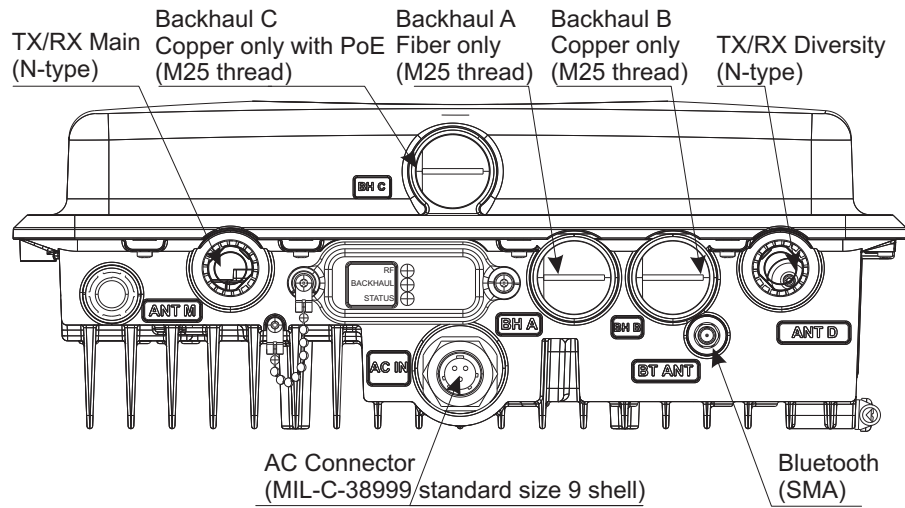

Figure 17 Flexi Zone Micro BTS (FWHC, FWHM) top view interfaces

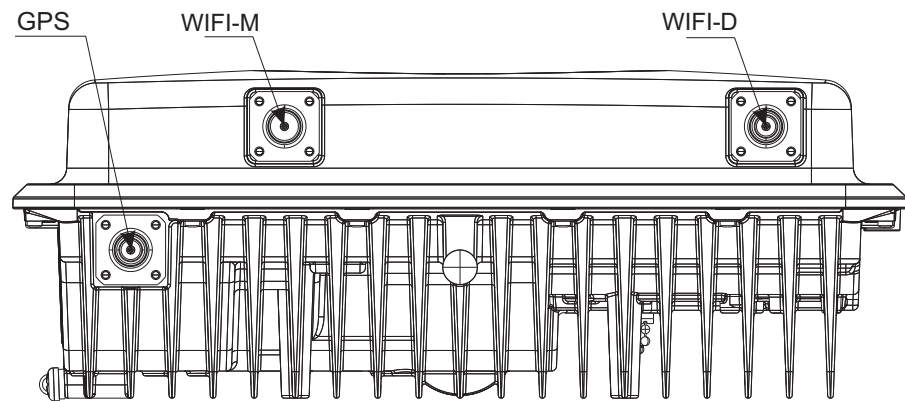
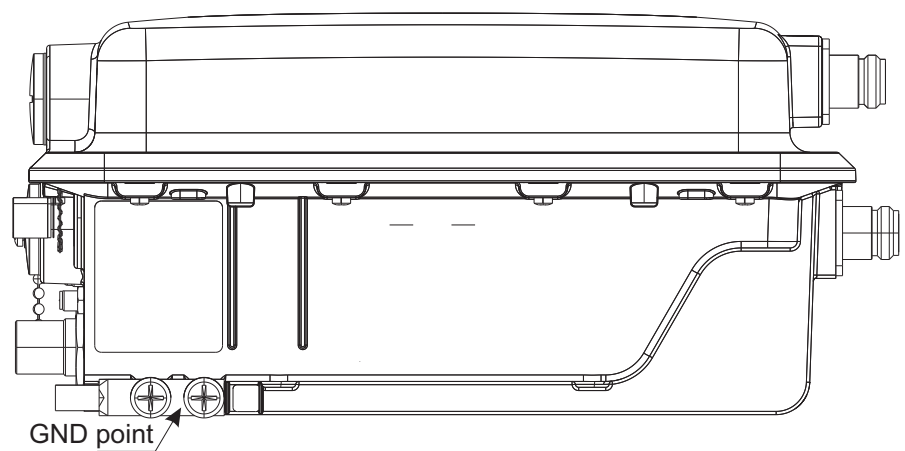

Figure 18 Flexi Zone Micro BTS (FWHC, FWHM) side view interfaces



8 Safety for Public and Workers

8.1 Installing base stations to ensure public safety

The equipment generates radio frequency energy, which has a thermal effect when absorbed by the human body. For this reason compliance boundaries specific to this equipment have been established. The thermal effects of radio frequency energy can exceed safety levels when a person is inside the established compliance boundaries. Observe the compliance boundary, and make sure the general public has no access to areas inside the established boundaries.

8.2 Installing base stations to ensure installer safety

Installation engineers need to be aware of the potential risk of the thermal effects of radio frequency energy and how to stay protected against undue risk.

When working close to transmitter antennas, the proper safety distances must be observed. The minimum safe distance from an antenna is measured in meters. When assessing the applicable compliance boundaries (CB) European standards EN 50383, EN 50385, Council Recommendation 1999/519/EC and FCC 47 CFR § 1.1310 for general public electromagnetic exposure limits have been applied.

The antenna types and gain actually configured on the product determine the minimum safe distance. Flexi Zone Micro small cell, is compliant with the cited standards at every point outside the FINAL boundary (CB) when the Flexi Zone Micro BTS is deployed with NSN provided antennas connected directly to the Flexi Zone Micro RF ports.

Consult site engineering plan for any other configurations.

Provisions must be taken to guarantee that no public access is possible to regions within the FINAL compliance boundaries. See [Table 12: Required Compliance Boundaries \(CB\) by band \(all single carrier FZM variants\)](#) or [Table 13: Required Compliance Boundaries \(CB\) by band \(all three carrier FZM variants\)](#).

Table 12 Required Compliance Boundaries (CB) by band (all single carrier FZM variants)

Required Compliance Boundaries (CB) (all single carrier FZM variants)				
Operating Band(s)	LTE Main CB ¹ [m]	LTE Div CB ¹ [m]	BT CB [m]	Final CB [m] ⁽¹⁾
Omni Antenna Configurations				
1, 2, 3, 4	0.34	0.72	0.13	0.72
7	0.39	0.51	0.13	0.66
Directional Antenna Configurations				
1, 2, 3, 4, 25	1.60		0.13	1.60
7	0.99		0.13	1.00

⁽¹⁾ 2x2 MIMO (LTE main and diversity transmit)

Table 13 Required Compliance Boundaries (CB) by band (all three carrier FZM variants)

Required Compliance Boundaries (CB) (all three carrier FZM variants)			
Operating Band(s)	LTE CB ¹ [m] (all antennas)	BT CB [m]	Final CB [m]
Omni Antenna Configurations only			
1, 2, 3, 4, 25	1.64	0.2	1.67
5, 12, 13	2.56	0.2	2.59
7, 41	1.52	0.2	1.55

⁽¹⁾ 2x2 MIMO (LTE main and diversity transmit)



WARNING! Electromagnetic field.

Do not go any closer to a live antenna than the compliance boundary. The radio frequency energy generated by the antenna poses a serious health risk.



WARNING! Electromagnetic field.

If performing installation or maintenance procedures on cables or antennas of the BTS in an area closer than the compliance boundary, make sure that all transmitters in this area are switched off.

9 Flexi Zone Micro BTS (FWHA) CE Marking

Figure 19 CE marking



Hereby, Nokia Solutions and Networks declares that this Base Station is in compliance with the essential requirements and other relevant provisions of Directive: 1999/5/EC.

10 Flexi Zone Micro BTS (FWIB, FWHD) United States FCC Part 15 compliance

RF Exposure (OET Bulletin 65)

To comply with FCC/IC RF exposure requirements for mobile transmitting devices, this transmitter should only be used or installed at locations where the separation distances between the antenna(s) and all persons are maintained as defined in [Table 12: Required Compliance Boundaries \(CB\) by band \(all single carrier FZM variants\)](#).

Flexi Zone Micro small cell is compliant with the cited standards at every point outside the FINAL boundary (CB) when the Flexi Zone Micro BTS is deployed with NSN provided antennas connected directly to the Flexi Zone Micro RF ports.

The antenna types and gain actually configured on the product determine the minimum safe distance. Consult site engineering plan for any other configurations using different LTE antennas. Provisions must be taken to guarantee that no public access is possible to regions within the compliance boundaries.

Compliance Statement (Part 15.19)

This device complies with Part 15 of the FCC Rules. Operation is subject to the following two conditions:

1. This device may not cause harmful interference, and
2. This device must accept any interference received, including interference that may cause undesired operation.

Warning (Part 15.21)

Changes or modifications not expressly approved by the party responsible for compliance could void the user's authority to operate the equipment.

FCC Interference Statement (Part 15.105 (b))

This equipment has been tested and found to comply with the limits for a Class B digital device, pursuant to Part 15 of the FCC Rules. These limits are designed to provide reasonable protection against harmful interference in a residential installation. This equipment generates uses and can radiate radio frequency energy and, if not installed and used in accordance with the instructions, may cause harmful interference to radio communications. However, there is no guarantee that interference will not occur in a particular installation. If this equipment does cause harmful interference to radio or television reception, which can be determined by turning the equipment off and on, the user is encouraged to try to correct the interference by one of the following measures:

- Reorient or relocate the receiving antenna.
- Increase the separation between the equipment and receiver.
- Connect the equipment into an outlet on a circuit different from that to which the receiver is connected.
- Consult the dealer or an experienced radio/TV technician for help.

11 Flexi Zone Micro BTS (FWIB, FWFA, FWHD) Industry Canada IC RSS-GEN compliance

Section 7.1.2 of RSS-GEN

Under Industry Canada regulations, this radio transmitter may only operate using an antenna of a type and maximum (or lesser) gain approved for the transmitter by Industry Canada. To reduce potential radio interference to other users, the antenna type and its gain should be so chosen that the equivalent isotropically radiated power (e.i.r.p.) is not more than that necessary for successful communication.

The following Flexi Zone Micro BTS radio transmitters 661W-FWIB, 661WAI-FWHD, 661W-FWFA and 661W- FZMBTM01 have been approved by Industry Canada to operate with the antenna types listed below with the maximum permissible gain and required antenna impedance for each antenna type indicated.

This device has been designed to operate with the antennas listed below.

- Omni antennas have a maximum gain of 2 dBi
- Directional antennas have a maximum gain of 9.7 dBi



Note that the Bluetooth antenna CANNOT be substituted or it will void the Bluetooth modular type approval.

Flexi Zone Micro small cell is compliant with the cited standards at every point outside the FINAL boundary (CB) when the Flexi Zone Micro BTS is deployed with NSN provided antennas connected directly to the Flexi Zone Micro RF ports.

The antenna types and gain actually configured on the product determine the minimum safe distance. Consult site engineering plan for any other configurations using different LTE antennas. Provisions must be taken to guarantee that no public access is possible to regions within the compliance boundaries.

The required antenna impedance is 50 ohms.

Flexi Zone Micro small cell, omni antenna configuration (1) consists of:

- Bluetooth (BT) antenna (Laird WXC2400SMRP-NS1)
- two LTE Omni-directional antennas (PCTEL MHO80617102NM)

Flexi Zone Micro small cell, directional antenna configuration (1) consists of:

- Bluetooth (BT) antenna (Laird WXC2400SMRP-NS1)
- two LTE directional antennas (Pulse 2013014)

Section 7.1.3 of RSS-GEN

This Device complies with Industry Canada License-exempt RSS standard(s). Operation is subject to the following two conditions:

1. this device may not cause interference, and
2. this device must accept any interference, including interference that may cause undesired operation of the device.

The same text in French.

Section 7.1.2 du CNR-GEN

En vertu de la réglementation d'Industrie Canada, cet émetteur radio peut fonctionner seulement en utilisant une antenne du type et du gain maximum (ou moins) approuvé pour un émetteur par Industrie Canada. Pour réduire les interférences radio potentielles aux autres utilisateurs, le type d'antenne et son gain devrait être choisie pour que la puissance isotrope rayonnée équivalente (p.i.r.e.) ne soit pas plus que ce qui est nécessaire pour une communication réussie.

Les radios émetteurs suivants 661W-FWIB, 661WAI-FWHD, 661W-FWFA et 661W-FZMBTM01 ont été approuvé par Industrie Canada à fonctionner avec les types d'antennes énumérés ci-dessous avec le gain maximum admissible et impédance d'antenne requis pour chaque type d'antenne indiqué.

Ce dispositif a été conçu pour fonctionner avec les antennes énumérées ci-dessous:

- Les antennes Omni ont un gain maximum de 2 dBi
- Les antennes directionnelles ont un gain maximum de 9.7 dBi



Notez que l'antenne Bluetooth NE PEUT PAS être substituée sinon elle annulera l'homologation de type modulaire de Bluetooth.

La petite cellule Flexi Zone Micro est compatible avec les normes citées en tout point à l'extérieur de la limite FINALE (CB) lorsque le Flexi Zone Micro BTS est déployé avec les antennes fournies par Nokia connectées directement aux RF ports du Flexi Zone Micro.

Les types d'antennes et gains présentement configurées sur le produit déterminent la distance minimum de sécurité. Consulter le plan d'ingénierie du site pour toute autre configuration utilisant différentes antennes LTE. Des mesures doivent être prises pour garantir qu'aucun accès public n'est possible aux régions dans les limites de conformité.

L'impédance requise des antennes est de 50 ohms.

La petite cellule Micro Zone Flexi, Omni configuration (1) se compose de:

- Antenne Bluetooth (BT) (Laird WXC2400SMRP-NS1)
- Deux antennes LTE Omni-directionnelles (PCTEL MHO80617102NM)

La petite cellule Flexi Zone Micro, antenne directionnelle configuration (1) se compose de:

- Antenne Bluetooth (BT) (Laird WXC2400SMRP-NS1)
- Deux antennes directionnelles LTE (Pulse 2013014)

Section 7.1.3 du CNR-GEN

Ce dispositif est conforme à l'exempts de License d'Industrie Canada (des standards RSS). L'opération est soumise aux deux conditions suivantes:

1. Ce dispositif ne doit pas causer de l'interférence, et
2. Ce dispositif doit accepter toutes interférences reçues, y compris les interférences pouvant entraîner des opérations non-désirées de l'appareil.

12 Flexi Zone Micro Bluetooth Modular Approval

The Bluetooth Module (Model number: FZM BLUETOOTH MODULE) has been certified for integration into the FZM product by Nokia Solutions and Networks under the following conditions:

1. The antenna(s) must be installed such that a minimum separation distance of 20cm is maintained between the radiator (antenna) and all persons at all times.
2. Since the transmitter module is co-located and operating in conjunction with another antenna or transmitter, additional compliance requirements required with this module installed (if any) may be found in the FCC/IC grants for this product.

13 EU RoHS statement

This equipment complies with the European Union RoHS Directive 2011/65/EU on the restriction of the use of certain hazardous substances in electrical and electronic equipment. The directive applies to the use of lead, mercury, cadmium, hexavalent chromium, polybrominated biphenyls (PBB), and polybrominated diphenyl ethers (PBDE) in electrical and electronic equipment.