

# *AAM1212*

*ADSL2+ Module in the IP DSLAM*

## *User's Guide*

Version 3.50  
10/2005

**ZyXEL**



# Copyright

## **Copyright © 2005 by ZyXEL Communications Corporation.**

The contents of this publication may not be reproduced in any part or as a whole, transcribed, stored in a retrieval system, translated into any language, or transmitted in any form or by any means, electronic, mechanical, magnetic, optical, chemical, photocopying, manual, or otherwise, without the prior written permission of ZyXEL Communications Corporation.

Published by ZyXEL Communications Corporation. All rights reserved.

## **Disclaimer**

ZyXEL does not assume any liability arising out of the application or use of any products, or software described herein. Neither does it convey any license under its patent rights nor the patent rights of others. ZyXEL further reserves the right to make changes in any products described herein without notice. This publication is subject to change without notice.

# Interference Statements and Warnings

## FCC Statement

This switch complies with Part 15 of the FCC rules. Operation is subject to the following two conditions:

- 1 This switch may not cause harmful interference.
- 2 This switch must accept any interference received, including interference that may cause undesired operations.

## FCC Warning

This equipment has been tested and found to comply with the limits for a Class A digital switch, pursuant to Part 15 of the FCC Rules. These limits are designed to provide reasonable protection against harmful interference in a commercial environment. This equipment generates, uses, and can radiate radio frequency energy and, if not installed and used in accordance with the instruction manual, may cause harmful interference to radio communications. Operation of this equipment in a residential area is likely to cause harmful interference in which case the user will be required to correct the interference at his own expense.

## CE Mark Warning:

This is a class A product. In a domestic environment this product may cause radio interference in which case the user may be required to take adequate measures.

## Taiwanese BSMI (Bureau of Standards, Metrology and Inspection) A Warning:

警告使用者  
這是甲類的資訊產品，在居住的環境使用時，  
可能造成射頻干擾，在這種情況下，  
使用者會被要求採取某些適當的對策。

## Certifications

- 1 Go to [www.zyxel.com](http://www.zyxel.com).
- 2 Select your product from the drop-down list box on the ZyXEL home page to go to that product's page.
- 3 Select the certification you wish to view from this page.

## Registration

Register your product online for free future product updates and information at [www.zyxel.com](http://www.zyxel.com) for global products, or at [www.us.zyxel.com](http://www.us.zyxel.com) for North American products.

## Safety Warnings

For your safety, be sure to read and follow all warning notices and instructions.

- To reduce the risk of fire, use only No. 26 AWG (American Wire Gauge) or larger telecommunication line cord.
- Do NOT open the device or unit. Opening or removing covers can expose you to dangerous high voltage points or other risks. ONLY qualified service personnel can service the device. Please contact your vendor for further information.
- Use ONLY the dedicated power supply for your device. Connect the power cord or power adaptor to the right supply voltage (110V AC in North America or 230V AC in Europe).
- Do NOT use the device if the power supply is damaged as it might cause electrocution.
- If the power supply is damaged, remove it from the power outlet.
- Do NOT attempt to repair the power supply. Contact your local vendor to order a new power supply.
- Place connecting cables carefully so that no one will step on them or stumble over them. Do NOT allow anything to rest on the power cord and do NOT locate the product where anyone can walk on the power cord.
- If you wall mount your device, make sure that no electrical, gas or water pipes will be damaged.
- Do NOT install nor use your device during a thunderstorm. There may be a remote risk of electric shock from lightning.
- Do NOT expose your device to dampness, dust or corrosive liquids.
- Do NOT use this product near water, for example, in a wet basement or near a swimming pool.
- Make sure to connect the cables to the correct ports.
- Do NOT obstruct the device ventilation slots, as insufficient airflow may harm your device.
- Do NOT store things on the device.
- Connect ONLY suitable accessories to the device.

# ZyXEL Limited Warranty

ZyXEL warrants to the original end user (purchaser) that this product is free from any defects in materials or workmanship for a period of up to two years from the date of purchase. During the warranty period, and upon proof of purchase, should the product have indications of failure due to faulty workmanship and/or materials, ZyXEL will, at its discretion, repair or replace the defective products or components without charge for either parts or labor, and to whatever extent it shall deem necessary to restore the product or components to proper operating condition. Any replacement will consist of a new or re-manufactured functionally equivalent product of equal value, and will be solely at the discretion of ZyXEL. This warranty shall not apply if the product is modified, misused, tampered with, damaged by an act of God, or subjected to abnormal working conditions.

## Note

Repair or replacement, as provided under this warranty, is the exclusive remedy of the purchaser. This warranty is in lieu of all other warranties, express or implied, including any implied warranty of merchantability or fitness for a particular use or purpose. ZyXEL shall in no event be held liable for indirect or consequential damages of any kind of character to the purchaser.

To obtain the services of this warranty, contact ZyXEL's Service Center for your Return Material Authorization number (RMA). Products must be returned Postage Prepaid. It is recommended that the unit be insured when shipped. Any returned products without proof of purchase or those with an out-dated warranty will be repaired or replaced (at the discretion of ZyXEL) and the customer will be billed for parts and labor. All repaired or replaced products will be shipped by ZyXEL to the corresponding return address, Postage Paid. This warranty gives you specific legal rights, and you may also have other rights that vary from country to country.

# Customer Support

Please have the following information ready when you contact customer support.

- Product model and serial number.
- Warranty Information.
- Date that you received your device.
- Brief description of the problem and the steps you took to solve it.

METHOD	SUPPORT E-MAIL	TELEPHONE*	WEB SITE	REGULAR MAIL
LOCATION	SALES E-MAIL	FAX	FTP SITE	
CORPORATE HEADQUARTERS (WORLDWIDE)	support@zyxel.com.tw	+886-3-578-3942	www.zyxel.com www.europe.zyxel.com	ZyXEL Communications Corp. 6 Innovation Road II Science Park Hsinchu 300 Taiwan
	sales@zyxel.com.tw	+886-3-578-2439	ftp.zyxel.com ftp.europe.zyxel.com	
CZECH REPUBLIC	info@cz.zyxel.com	+420-241-091-350	www.zyxel.cz	ZyXEL Communications Czech s.r.o. Modranská 621 143 01 Praha 4 - Modrany Ceská Republika
	info@cz.zyxel.com	+420-241-091-359		
DENMARK	support@zyxel.dk	+45-39-55-07-00	www.zyxel.dk	ZyXEL Communications A/S Columbusvej 2860 Soeborg Denmark
	sales@zyxel.dk	+45-39-55-07-07		
FINLAND	support@zyxel.fi	+358-9-4780-8411	www.zyxel.fi	ZyXEL Communications Oy Malminkaari 10 00700 Helsinki Finland
	sales@zyxel.fi	+358-9-4780 8448		
FRANCE	info@zyxel.fr	+33-4-72-52-97-97	www.zyxel.fr	ZyXEL France 1 rue des Vergers Bat. 1 / C 69760 Limonest France
		+33-4-72-52-19-20		
GERMANY	support@zyxel.de	+49-2405-6909-0	www.zyxel.de	ZyXEL Deutschland GmbH. Adenauerstr. 20/A2 D-52146 Wuerselen Germany
	sales@zyxel.de	+49-2405-6909-99		
HUNGARY	support@zyxel.hu	+36-1-3361649	www.zyxel.hu	ZyXEL Hungary 48, Zoldlomb Str. H-1025, Budapest Hungary
	info@zyxel.hu	+36-1-3259100		
KAZAKHSTAN	http://zyxel.kz/support	+7-3272-590-698	www.zyxel.kz	ZyXEL Kazakhstan 43, Dostyk ave., Office 414 Dostyk Business Centre 050010, Almaty Republic of Kazakhstan
	sales@zyxel.kz	+7-3272-590-689		
NORTH AMERICA	support@zyxel.com	1-800-255-4101 +1-714-632-0882	www.us.zyxel.com	ZyXEL Communications Inc. 1130 N. Miller St. Anaheim CA 92806-2001 U.S.A.
	sales@zyxel.com	+1-714-632-0858	ftp.us.zyxel.com	
NORWAY	support@zyxel.no	+47-22-80-61-80	www.zyxel.no	ZyXEL Communications A/S Niils Hansens vei 13 0667 Oslo Norway
	sales@zyxel.no	+47-22-80-61-81		

METHOD	SUPPORT E-MAIL	TELEPHONE*	WEB SITE	REGULAR MAIL
	SALES E-MAIL	FAX	FTP SITE	
POLAND	info@pl.zyxel.com	+48-22-5286603	www.pl.zyxel.com	Zyxel Communications ul.Emilli Plater 53 00-113 Warszawa Poland
		+48-22-5206701		
RUSSIA	http://zyxel.ru/support	+7-095-542-89-29	www.zyxel.ru	ZyXEL Russia Ostrovityanova 37a Str. Moscow, 117279 Russia
	sales@zyxel.ru	+7-095-542-89-25		
SPAIN	support@zyxel.es	+34-902-195-420	www.zyxel.es	ZyXEL Communications Alejandro Villegas 33 1º, 28043 Madrid Spain
	sales@zyxel.es	+34-913-005-345		
SWEDEN	support@zyxel.se	+46-31-744-7700	www.zyxel.se	ZyXEL Communications A/S Sjöporten 4, 41764 Göteborg Sweden
	sales@zyxel.se	+46-31-744-7701		
UKRIANE	support@ua.zyxel.com	+380-44-247-69-78	www.ua.zyxel.com	ZyXEL Ukraine 13, Pimonenko Str. Kiev, 04050 Ukraine
	sales@ua.zyxel.com	+380-44-494-49-32		
UNITED KINGDOM	support@zyxel.co.uk	+44-1344 303044 08707 555779 (UK only)	www.zyxel.co.uk	ZyXEL Communications UK Ltd., 11 The Courtyard, Eastern Road, Bracknell, Berkshire, RG12 2XB, United Kingdom (UK)
	sales@zyxel.co.uk	+44-1344 303034	ftp.zyxel.co.uk	

\* "+" is the (prefix) number you enter to make an international telephone call.

# Table of Contents

<b>Copyright .....</b>	<b>1</b>
<b>Interference Statements and Warnings .....</b>	<b>2</b>
<b>ZyXEL Limited Warranty .....</b>	<b>4</b>
<b>Customer Support.....</b>	<b>5</b>
<b>Preface .....</b>	<b>27</b>
<b>Chapter 1</b>	
<b>Getting to Know Your AAM1212 .....</b>	<b>29</b>
1.1 Introduction .....	29
1.2 System Description .....	29
1.3 Applications .....	32
1.3.1 MTU Application .....	32
1.3.2 Curbside Application .....	33
<b>Chapter 2</b>	
<b>Removing and Installing the AAM .....</b>	<b>35</b>
2.1 Removing the AAM .....	35
2.2 Installing the AAM .....	36
<b>Chapter 3</b>	
<b>Hardware Connections .....</b>	<b>37</b>
3.1 Front Panel .....	37
3.1.1 Front Panel Ports .....	37
3.1.2 Front Panel LEDs .....	37
3.1.3 Console Port .....	38
3.1.3.1 Default Ethernet Settings .....	38
3.1.4 LAN Port (Ethernet) Connection .....	38
3.1.5 Notes About MDFs (Main Distribution Frames) .....	39
3.1.6 Telco-50 Cables .....	40
3.1.7 Telco-50 Connections .....	41
3.1.8 ADSL Connections .....	41
3.1.9 Typical MDF Scenarios .....	42
3.1.9.1 Installation Scenario A .....	42

3.1.9.2 Installation Scenario B .....	43
3.1.9.3 Installation Scenario C .....	46
<b>Chapter 4</b>	
<b>Web Configurator Introduction .....</b>	<b>49</b>
4.1 Web Configurator Overview .....	49
4.2 Accessing the Web Configurator .....	49
4.2.1 Password .....	49
4.3 Home Screen .....	50
4.4 Saving Your Configuration .....	53
4.5 Changing Your Password .....	53
4.6 Logging Out of the Web Configurator .....	53
<b>Chapter 5</b>	
<b>Initial Configuration .....</b>	<b>55</b>
5.1 Initial Configuration Overview .....	55
5.2 Initial Configuration .....	55
5.3 Default Settings .....	60
<b>Chapter 6</b>	
<b>Home and Port Statistics Screens .....</b>	<b>63</b>
6.1 Home and Port Statistics Screens Overview .....	63
6.2 Home Screen .....	63
6.2.1 Ethernet Port Statistics .....	64
6.2.2 ADSL Port Statistics .....	67
<b>Chapter 7</b>	
<b>Basic Setting Screens .....</b>	<b>71</b>
7.1 Basic Setting Screens Overview .....	71
7.2 System Information .....	71
7.3 General Setup .....	73
7.4 IGMP Snooping .....	75
7.5 Switch Modes .....	75
7.5.1 Standalone Switch Mode .....	75
7.5.2 Port Isolation with Standalone Switch Mode Example .....	76
7.5.3 Daisychain Switch Mode .....	77
7.5.4 Port Isolation with Daisychain Switch Mode Example .....	77
7.6 Switch Setup Screen .....	78
7.7 IP Setup .....	80
7.8 ENET Port Setup .....	80

<b>Chapter 8</b>	
<b>ADSL Port Setup</b> .....	<b>83</b>
8.1 ADSL Standards Overview .....	83
8.2 Downstream and Upstream .....	83
8.3 Profiles .....	83
8.4 Interleave Delay .....	84
8.4.1 Fast Mode .....	84
8.5 Configured Versus Actual Rate .....	84
8.6 Default Settings .....	85
8.7 xDSL Port Setup .....	85
8.7.1 xDSL Port Setting .....	87
8.8 Virtual Channels .....	88
8.8.1 Super Channel .....	89
8.8.2 LLC .....	89
8.8.3 VC Mux .....	89
8.8.4 Virtual Channel Profile .....	89
8.9 VC Setup Screen .....	90
8.10 Port Profile Screen .....	93
8.11 ATM QoS .....	96
8.12 Traffic Shaping .....	96
8.12.1 ATM Traffic Classes .....	96
8.12.1.1 Constant Bit Rate (CBR) .....	96
8.12.1.2 Variable Bit Rate (VBR) .....	96
8.12.1.3 Unspecified Bit Rate (UBR) .....	97
8.12.2 Traffic Parameters .....	97
8.12.2.1 Peak Cell Rate (PCR) .....	97
8.12.2.2 Sustained Cell Rate (SCR) .....	97
8.12.2.3 Maximum Burst Size (MBS) .....	97
8.12.2.4 Cell Delay Variation Tolerance (CDVT) .....	98
8.12.2.5 Burst Tolerance (BT) .....	98
8.12.2.6 Theoretical Arrival Time (TAT) .....	98
8.13 VC Profile Screen .....	98
8.14 Alarm Profile Screen .....	100
8.15 IGMP Filter Profile Screen .....	102
8.16 Line Rate Information .....	104
8.17 Line Performance .....	106
8.17.1 Line Data .....	107
<b>Chapter 9</b>	
<b>VLAN</b> .....	<b>111</b>
9.1 Introduction to VLANs .....	111
9.2 Introduction to IEEE 802.1Q Tagged VLAN .....	111
9.2.1 Forwarding Tagged and Untagged Frames .....	112

9.3 Automatic VLAN Registration .....	112
9.3.1 GARP .....	112
9.3.1.1 GARP Timers .....	113
9.3.2 GVRP .....	113
9.4 VLAN Status .....	113
9.5 Static VLAN Setting .....	115
9.6 VLAN Port Setting .....	116
<b>Chapter 10</b>	
<b>IGMP Snooping .....</b>	<b>119</b>
10.1 IGMP Snooping .....	119
10.2 IGMP Snooping Screen .....	119
<b>Chapter 11</b>	
<b>Static Multicast .....</b>	<b>121</b>
11.1 Static Multicast Filter .....	121
11.2 Static Multicast Screen .....	121
<b>Chapter 12</b>	
<b>Packet Filtering .....</b>	<b>123</b>
12.1 Packet Filter Configuration .....	123
<b>Chapter 13</b>	
<b>MAC Filter .....</b>	<b>125</b>
13.1 MAC Filter Introduction .....	125
13.2 MAC Filter Configuration .....	125
<b>Chapter 14</b>	
<b>Spanning Tree Protocol .....</b>	<b>127</b>
14.1 RSTP (Rapid Spanning Tree Protocol) and STP (Spanning Tree Protocol) ...	127
14.2 STP Status .....	129
14.2.1 Configure STP .....	131
<b>Chapter 15</b>	
<b>Port Authentication .....</b>	<b>133</b>
15.1 Introduction to Authentication .....	133
15.1.1 RADIUS .....	133
15.1.2 Introduction to Local User Database .....	133
15.2 Port Authentication Configuration .....	133
15.2.1 IEEE 802.1x Configuration .....	135

---

<b>Chapter 16</b>	
<b>Port Security .....</b>	<b>137</b>
16.1 About Port Security .....	137
16.2 Port Security Setup .....	137
<b>Chapter 17</b>	
<b>DHCP Relay .....</b>	<b>139</b>
17.1 DHCP Relay Overview .....	139
17.1.1 DHCP Relay Agent Information .....	139
17.2 DHCP Relay Setup .....	139
<b>Chapter 18</b>	
<b>Syslog .....</b>	<b>141</b>
18.1 Syslog .....	141
18.2 Syslog Setup .....	141
<b>Chapter 19</b>	
<b>Access Control.....</b>	<b>143</b>
19.1 About Access Control .....	143
19.2 Access Control Overview .....	143
19.3 About SNMP .....	144
19.3.1 Supported MIBs .....	145
19.3.2 RFC-1215 SNMP Traps .....	145
19.3.3 ZyXEL Private MIB SNMP Traps .....	146
19.3.4 Configuring SNMP .....	146
19.3.5 Setting Up the Administrator Login Account .....	147
19.3.6 Service Access Control Configuration .....	148
19.3.7 Secured Client Configuration .....	149
<b>Chapter 20</b>	
<b>Routing Protocol.....</b>	<b>151</b>
20.1 Static Route .....	151
<b>Chapter 21</b>	
<b>Maintenance .....</b>	<b>153</b>
21.1 Maintenance .....	153
21.2 Firmware Upgrade .....	153
21.3 Restore a Text Configuration File .....	154
21.4 Backing Up a Configuration File .....	154
21.5 Load Factory Defaults .....	155
21.6 Reboot System .....	155
21.7 Command Line FTP .....	156

<b>Chapter 22</b>	
<b>Diagnostic</b> .....	<b>157</b>
22.1 Diagnostic .....	157
22.2 Log Format .....	158
22.2.1 Log Messages .....	159
22.3 Line Diagnostics Test Parameters .....	160
<b>Chapter 23</b>	
<b>MAC Table</b> .....	<b>163</b>
23.1 Introduction to MAC Table .....	163
23.2 Viewing the MAC Table .....	164
<b>Chapter 24</b>	
<b>ARP Table</b> .....	<b>165</b>
24.1 Introduction to ARP Table .....	165
24.1.1 How ARP Works .....	165
24.2 Viewing the ARP Table .....	165
<b>Chapter 25</b>	
<b>Commands Overview</b> .....	<b>167</b>
25.1 Command Line Interface .....	167
25.1.1 Saving Your Configuration .....	167
25.2 Commands Summary .....	168
<b>Chapter 26</b>	
<b>Sys Commands</b> .....	<b>181</b>
26.1 Sys Commands Summary .....	181
26.2 Sys Command Examples .....	183
26.2.1 Info Show Command .....	183
26.2.2 Password Command .....	184
26.2.3 SNMP Overview .....	184
26.2.4 SNMP Commands .....	185
26.2.4.1 Get Community Command .....	185
26.2.4.2 Set Community Command .....	185
26.2.4.3 Trusted Host Set Command .....	185
26.2.4.4 Trap Community Command .....	186
26.2.4.5 Trap Destination Set Command .....	186
26.2.4.6 Show SNMP Settings Command .....	186
26.2.5 Server Show Command .....	186
26.2.6 Server Port Command .....	187
26.2.7 Client Show Command .....	187
26.2.8 Client Set Command .....	188
26.2.9 Syslog Show Command .....	188

26.2.10 Syslog Server Command .....	188
26.2.11 Syslog Enable Command .....	189
26.2.12 Time Show Command .....	189
26.2.13 Time Set Command .....	189
26.2.14 Date Show Command .....	189
26.2.15 Date Set Command .....	190
26.2.16 Time Server Show Command .....	190
26.2.17 Time Server Set Command .....	190
26.2.18 Log Show Command .....	191
26.2.19 Log Clear Command .....	192
26.2.20 Monitor Show Command .....	192
26.2.21 Monitor Vlimit Command .....	192
26.2.22 Monitor Tlimit Command .....	193

## Chapter 27

### ADSL Commands..... 195

27.1 ADSL Standards Overview .....	195
27.2 ADSL Commands Summary .....	195
27.3 ADSL Command Examples .....	200
27.3.1 ADSL Show Command .....	200
27.3.2 ADSL Enable Command .....	201
27.3.3 ADSL Disable Command .....	201
27.3.4 ADSL Profile Show Command .....	202
27.3.5 ADSL Profile Set Command .....	202
27.3.6 ADSL Profile Delete Command .....	204
27.3.7 ADSL Profile Map Command .....	204
27.3.8 ADSL Name Command .....	205
27.3.9 ADSL Tel Command .....	205
27.3.10 ADSL Loopback Command .....	206
27.3.11 Line Diagnostics Set Command .....	207
27.3.12 Line Diagnostics Get Command .....	207
27.3.13 ADSL Alarm Profile Commands .....	208
27.3.14 Alarm Profile Show Command .....	208
27.3.15 Alarm Profile Set Command .....	209
27.3.16 Alarm Profile Delete Command .....	210
27.3.17 Alarm Profile Map Command .....	211
27.3.18 Alarm Profile Showmap Command .....	211
27.4 Virtual Channel Profile Commands .....	212
27.4.1 Show Virtual Channel Profile Command .....	212
27.4.2 Set Virtual Channel Profile Command .....	212
27.4.3 Delete Virtual Channel Profile Command .....	214
27.5 PVC Channels .....	214
27.5.1 PVC Show Command .....	214

27.5.2 PVC Set Command .....	215
27.5.3 PVC Delete Command .....	216

## **Chapter 28**

### **Switch Commands ..... 217**

28.1 Switch Commands Summary .....	217
28.2 IGMP Filter Commands .....	222
28.2.1 IGMP Filter Show Command .....	222
28.2.2 IGMP Filter Set Command .....	222
28.2.3 IGMP Filter Profile Set Command .....	223
28.2.4 IGMP Filter Profile Delete Command .....	224
28.2.5 IGMP Filter Profile Show Command .....	224
28.3 DHCP Relay Overview .....	225
28.4 DHCP Relay Commands .....	225
28.4.1 DHCP Relay Server Set Command .....	225
28.4.2 DHCP Relay Enable Command .....	226
28.4.3 DHCP Relay Disable Command .....	226
28.4.4 DHCP Relay Show Command .....	226
28.5 DHCP Relay Option 82 (Agent Information) .....	226
28.5.1 Option 82 Enable Command .....	226
28.5.2 Option 82 Disable Command .....	227
28.5.3 Option 82 Set Command .....	227
28.6 IEEE 802.1Q Tagged VLAN Overview .....	227
28.7 Filtering Databases .....	227
28.7.1 Static Entries (SVLAN Table) .....	228
28.7.2 Dynamic Entries (DVLAN Table) .....	228
28.8 IEEE VLAN1Q Tagged VLAN Configuration Commands .....	228
28.8.1 GARP Timer Show Command .....	228
28.8.2 GARP Timer Join Command .....	228
28.8.3 GARP Timer Leave Command .....	229
28.8.4 GARP Timer Leaveall Command .....	229
28.8.5 VLAN Port Show Command .....	230
28.8.6 VLAN PVID Command .....	231
28.8.7 VLAN Set Command .....	231
28.8.7.1 Modify a Static VLAN Table Example .....	232
28.8.7.2 Forwarding Process Example .....	232
28.8.8 VLAN Frame Type Command .....	233
28.8.9 VLAN CPU Show Command .....	234
28.8.10 VLAN CPU Set Command .....	234
28.8.11 Configuring Management VLAN Example .....	234
28.8.12 VLAN Priority Command .....	235
28.8.13 VLAN Delete Command .....	235
28.9 VLAN Enable .....	236

---

28.10 VLAN Disable .....	236
28.10.1 VLAN Show Command .....	236
28.11 MAC Filter Commands .....	237
28.11.1 MAC Filter Show Command .....	237
28.11.2 MAC Filter Enable Command .....	238
28.11.3 MAC Filter Disable Command .....	238
28.11.4 MAC Filter Set Command .....	239
28.11.5 MAC Filter Delete Command .....	239
28.12 MAC Count Commands .....	240
28.12.1 MAC Count Show Command .....	240
28.12.2 MAC Count Enable Command .....	240
28.12.3 MAC Count Disable Command .....	241
28.12.4 MAC Count Set Command .....	241
28.13 Packet Filter Commands .....	242
28.13.1 Packet Filter Show Command .....	242
28.13.2 Packet Filter Set Command .....	243

## **Chapter 29**

### **IP Commands ..... 245**

29.1 IP Commands Introduction .....	245
29.2 IP Settings and Default Gateway .....	245
29.3 IP Commands Summary .....	246
29.4 General IP Commands .....	247
29.4.1 Show Command .....	247
29.4.2 Ping Command .....	247
29.4.3 Route Set Command .....	247
29.4.4 Route Delete Command .....	248
29.4.5 Route Show Command .....	248
29.4.6 ARP Show Command .....	249
29.4.7 ARP Flush Command .....	249

## **Chapter 30**

### **Statistics Commands ..... 251**

30.1 Statistics Commands Summary .....	251
30.2 Statistics Monitor Command .....	252
30.3 Statistics Port Command .....	252
30.4 Statistics ADSL Commands .....	254
30.4.1 Statistics ADSL Show Command .....	254
30.4.2 Statistics ADSL Linedata Command .....	254
30.4.3 Statistics ADSL Lineinfo Command .....	255
30.4.4 ADSL Lineperf Command .....	257
30.4.5 ADSL 15 Minute Performance Command .....	258
30.4.6 ADSL 1 Day Performance Command .....	260

30.5 Statistics IP Command .....	261
<b>Chapter 31</b>	
<b>Config Commands .....</b>	<b>263</b>
31.1 Config Commands Summary .....	263
31.2 Config show Command Example .....	263
<b>Chapter 32</b>	
<b>Firmware and Configuration File Maintenance .....</b>	<b>265</b>
32.1 Firmware and Configuration File Maintenance Overview .....	265
32.2 Filename Conventions .....	265
32.3 Editable Configuration File .....	266
32.3.1 Editable Configuration File Backup .....	266
32.3.2 Edit Configuration File .....	267
32.3.3 Editable Configuration File Upload .....	267
32.4 Firmware File Upgrade .....	268
<b>Chapter 33</b>	
<b>Troubleshooting .....</b>	<b>269</b>
33.1 The SYS or PWR LED Does Not Turn On .....	269
33.2 The ALM LED Is On .....	269
33.3 DSL Data Transmission .....	270
33.4 There Is No Voice on an ADSL Connection .....	270
33.5 Testing Wiring .....	270
33.6 Local Server .....	272
33.7 Data Rate .....	273
33.8 Configured Settings .....	273
33.9 Password .....	273
33.10 SNMP .....	273
33.11 Telnet .....	274
33.12 Switch Lockout .....	274
33.13 Resetting the Defaults .....	274
33.13.1 Resetting the Defaults Via CLI Command .....	275
33.13.2 Resetting the Defaults Via Boot Commands .....	275
33.14 Recovering the Firmware .....	276
<b>Appendix A</b>	
<b>Product Specifications .....</b>	<b>279</b>
<b>Appendix B</b>	
<b>Virtual Circuit Topology .....</b>	<b>283</b>
<b>Index .....</b>	<b>285</b>

# List of Figures

Figure 1 MTU Application .....	33
Figure 2 Curbside Application .....	33
Figure 3 Loosen Module Screws .....	35
Figure 4 Removing the AAM from the IES-1000 Chassis .....	35
Figure 5 Installing the AAM in the IES-1000 Chassis .....	36
Figure 6 Tighten Module Screws .....	36
Figure 7 Front Panel .....	37
Figure 8 Stacking Multiple IES-1000 Units .....	39
Figure 9 MDF Wiring .....	40
Figure 10 Telco-50 Cable with RJ-11 Connectors .....	41
Figure 11 Installation Overview .....	42
Figure 12 Installation Scenario A .....	43
Figure 13 One MDF for End-user and CO Connections .....	44
Figure 14 Installation Scenario B .....	45
Figure 15 Two Separate MDFs for End-user and CO Connections .....	46
Figure 16 Installation Scenario C .....	47
Figure 17 Login Screen .....	50
Figure 18 Home Screen .....	50
Figure 19 Web Configurator: Change Password .....	53
Figure 20 Web Configurator: Logout Screen .....	53
Figure 21 Login Screen .....	55
Figure 22 Basic Setting IP Setup Menu .....	56
Figure 23 IP setup .....	56
Figure 24 Basic Setting xDSL Port Setup Menu .....	57
Figure 25 xDSL Port Setup .....	57
Figure 26 Deleting a PVC .....	58
Figure 27 Select Ports .....	58
Figure 28 Adding a New Channel .....	59
Figure 29 Copying the PVC .....	59
Figure 30 Select Ports .....	59
Figure 31 Config Save Menu .....	60
Figure 32 Config Save Screen .....	60
Figure 33 Home .....	63
Figure 34 Ethernet Port Statistics .....	65
Figure 35 ADSL Port Statistics .....	68
Figure 36 System Information .....	72

Figure 37 General Setup .....	74
Figure 38 Port Isolation with Standalone Switch Mode Example .....	76
Figure 39 Port Isolation with Daisychain Switch Mode Example .....	77
Figure 40 Switch Setup .....	78
Figure 41 IP Setup .....	80
Figure 42 ENET Port Setup .....	81
Figure 43 xDSL Port Setup .....	85
Figure 44 xDSL Port Setting .....	87
Figure 45 VC Setup .....	90
Figure 46 Port Profile .....	94
Figure 47 PCR, SCR and MBS in Traffic Shaping .....	97
Figure 48 TAT, CDVT and BT in Traffic Shaping .....	98
Figure 49 VC Profile .....	99
Figure 50 Alarm Profile .....	101
Figure 51 IGMP Filter Profile .....	103
Figure 52 Line Rate Information .....	104
Figure 53 Line Performance .....	106
Figure 54 Line Data .....	108
Figure 55 VLAN Status .....	114
Figure 56 Static VLAN Setting .....	115
Figure 57 VLAN Port Setting .....	117
Figure 58 IGMP Snooping .....	119
Figure 59 Static Multicast .....	121
Figure 60 Packet Filter .....	123
Figure 61 MAC Filter .....	125
Figure 62 STP Root Ports and Designated Ports .....	128
Figure 63 Spanning Tree Protocol: Status .....	129
Figure 64 Spanning Tree Protocol: Configuration .....	131
Figure 65 RADIUS Server .....	133
Figure 66 Port Authentication: RADIUS .....	134
Figure 67 Port Authentication: 802.1x .....	135
Figure 68 Port Security .....	137
Figure 69 DHCP Relay .....	140
Figure 70 Syslog .....	141
Figure 71 Access Control .....	143
Figure 72 Console Port Priority .....	143
Figure 73 SNMP Management Model .....	144
Figure 74 Access Control: SNMP .....	146
Figure 75 Access Control: Logins .....	147
Figure 76 Access Control: Service Access Control .....	148
Figure 77 Access Control: Secured Client Setup .....	149
Figure 78 Static Routing .....	151
Figure 79 Static Routing: Summary Table .....	152

---

Figure 80 Maintenance .....	153
Figure 81 Firmware Upgrade .....	154
Figure 82 Restore Configuration .....	154
Figure 83 Confirm Restore Factory Default Settings .....	155
Figure 84 Restart After Load Factory Defaults .....	155
Figure 85 Confirm Restart .....	156
Figure 86 Diagnostic .....	157
Figure 87 MAC Table Filtering Flowchart .....	163
Figure 88 MAC Table .....	164
Figure 89 ARP Table .....	166
Figure 90 Info Show Command Example .....	184
Figure 91 Passwd Command Example .....	184
Figure 92 Server Show Command Example .....	187
Figure 93 Server Port Command Example .....	187
Figure 94 Client Show Command Example .....	187
Figure 95 Client Set Command Example .....	188
Figure 96 Syslog Show Command Example .....	188
Figure 97 Syslog Server Command Example .....	188
Figure 98 Syslog Enable Command Example .....	189
Figure 99 Time Show Command Example .....	189
Figure 100 Time Set Command Example .....	189
Figure 101 Date Show Command Example .....	190
Figure 102 Date Set Command Example .....	190
Figure 103 Time Server Show Command Example .....	190
Figure 104 Time Server Set Command Example .....	191
Figure 105 Log Show Command Example .....	192
Figure 106 Monitor Show Command Example .....	192
Figure 107 Monitor Vlimit Command Example .....	193
Figure 108 Monitor Tlimit Command Example .....	194
Figure 109 ADSL Show Command Example .....	201
Figure 110 ADSL Profile Show Command Example .....	202
Figure 111 ADSL Profile Delete Command Example .....	204
Figure 112 ADSL Profile Map Command Example .....	205
Figure 113 ADSL Name Command Example .....	205
Figure 114 ADSL Tel Command Example .....	206
Figure 115 ADSL Profile Loopback Example .....	207
Figure 116 ADSL Line Diagnostics Set Command Example .....	207
Figure 117 ADSL Line Diagnostics Get Command Example .....	208
Figure 118 Alarm Profile Show Command Example .....	209
Figure 119 Alarm Profile Set Command Example .....	210
Figure 120 Alarm Profile Delete Command Example .....	211
Figure 121 Alarm Profile Map Command Example .....	211
Figure 122 Alarm Profile Showmap Command Example .....	212

Figure 123 Virtual Channel Profile Delete Command Example .....	214
Figure 124 PVC Set Command Example .....	216
Figure 125 IGMP Filter Show Command Example .....	222
Figure 126 IGMP Filter Set Command Example .....	223
Figure 127 IGMP Filter Profile Set Command Example .....	224
Figure 128 IGMP Filter Profile Delete Command Example .....	224
Figure 129 IGMP Filter Show Command Example .....	225
Figure 130 DHCP Relay Show Command Example .....	226
Figure 131 GARP Timer Show Command Example .....	228
Figure 132 GARP Timer Join Command Example .....	229
Figure 133 GARP Timer Leave Command Example .....	229
Figure 134 GARP Timer Leaveall Command Example .....	230
Figure 135 VLAN Port Show Command Example .....	230
Figure 136 VLAN PVID Command Example .....	231
Figure 137 Modifying the Static VLAN Example .....	232
Figure 138 VLAN Frame Type Command Example .....	234
Figure 139 CPU VLAN Configuration and Activation Example .....	235
Figure 140 Deleting Default VLAN Example .....	235
Figure 141 VLAN Priority Command Example .....	235
Figure 142 VLAN Delete Command Example .....	236
Figure 143 VLAN Show Command Example .....	237
Figure 144 MAC Filter Show Command Example .....	238
Figure 145 MAC Filter Enable Command Example .....	238
Figure 146 MAC Filter Disable Command Example .....	239
Figure 147 MAC Filter Set Command Example .....	239
Figure 148 MAC Filter Delete Command Example .....	240
Figure 149 MAC Count Show Command Example .....	240
Figure 150 MAC Count Enable Command Example .....	241
Figure 151 MAC Count Disable Command Example .....	241
Figure 152 MAC Count Set Command Example .....	242
Figure 153 Packet Filter Show Command Example .....	243
Figure 154 Packet Filter Set Command Example .....	244
Figure 155 IP Settings and Default Gateway Address .....	246
Figure 156 Route Show Command Example .....	249
Figure 157 ARP Show Command Example .....	249
Figure 158 Statistics Monitor Command Example .....	252
Figure 159 Statistics Port Command Example .....	253
Figure 160 ADSL Show Command Example .....	254
Figure 161 Linedata Command Example .....	255
Figure 162 Lineinfo Command Example .....	256
Figure 163 Lineperf Command Example .....	257
Figure 164 ADSL 15 Minute Performance Command Example .....	259
Figure 165 ADSL 1 Day Performance Command Example .....	261

Figure 166 Statistics IP Command Example .....	261
Figure 167 Config Show Command Example .....	264
Figure 168 Configuration File Example .....	267
Figure 169 Testing In-house Wiring .....	271
Figure 170 Resetting the AAM Via Command .....	275
Figure 171 Example Xmodem Upload .....	276
Figure 172 Example Xmodem Upload .....	277
Figure 173 Telco-50 Pin Assignments .....	281
Figure 174 Console Cable RJ-11 Male Connector .....	282
Figure 175 Console Cable DB-9 Female Connector .....	282
Figure 176 Virtual Circuit Topology .....	283



# List of Tables

Table 1 Front Panel Ports .....	37
Table 2 Front Panel LEDs Description .....	37
Table 3 Navigation Panel Sub-links Overview .....	51
Table 4 Web Configurator Screens .....	51
Table 5 Default Settings .....	60
Table 6 Home .....	64
Table 7 Ethernet Port Statistics .....	65
Table 8 ADSL Port Statistics .....	68
Table 9 System Information .....	72
Table 10 General Setup .....	74
Table 11 Switch Setup .....	78
Table 12 IP Setup .....	80
Table 13 ENET Port Setup .....	81
Table 14 Maximum Transfer Rates of the ADSL Ports .....	83
Table 15 xDSL Port Setup .....	86
Table 16 xDSL Port Setting .....	88
Table 17 VC Setup .....	90
Table 18 Port Profile .....	94
Table 19 VC Profile .....	99
Table 20 Alarm Profile .....	101
Table 21 IGMP Filter Profile .....	103
Table 22 Line Rate Information .....	105
Table 23 Line Performance .....	106
Table 24 Line Data .....	109
Table 25 IEEE 802.1Q VLAN Terminology .....	113
Table 26 VLAN Status .....	114
Table 27 Static VLAN Setting .....	115
Table 28 VLAN Port Setting .....	117
Table 29 IGMP Snooping .....	120
Table 30 Static Multicast .....	121
Table 31 Packet Filter .....	123
Table 32 MAC Filter .....	126
Table 33 STP Path Costs .....	127
Table 34 RSTP Port States .....	128
Table 35 Spanning Tree Protocol: Status .....	129
Table 36 Spanning Tree Protocol: Configuration .....	131

Table 37 Port Authentication: RADIUS .....	134
Table 38 Port Authentication: 802.1x .....	136
Table 39 Port Security .....	138
Table 40 DHCP Relay .....	140
Table 41 Syslog .....	141
Table 42 Access Control Overview .....	143
Table 43 SNMP Commands .....	145
Table 44 RFC-1215 SNMP Traps .....	145
Table 45 ZyXEL Private MIB SNMP Traps .....	146
Table 46 Access Control: SNMP .....	147
Table 47 Access Control: Logins .....	148
Table 48 Access Control: Service Access Control .....	148
Table 49 Access Control: Secured Client Setup .....	149
Table 50 Static Routing .....	151
Table 51 Static Routing: Summary Table .....	152
Table 52 Diagnostic .....	158
Table 53 Log Format .....	158
Table 54 Log Messages .....	159
Table 55 Line Diagnostics Test Parameters .....	160
Table 56 MAC Table .....	164
Table 57 ARP Table .....	166
Table 58 Commands .....	168
Table 59 Sys Commands .....	181
Table 60 ADSL Commands .....	195
Table 61 Switch Commands .....	217
Table 62 IP Commands .....	246
Table 63 Statistics Commands .....	251
Table 64 Line Performance Counters .....	258
Table 65 ADSL 15 Minute Performance Counters .....	259
Table 66 Config Commands .....	263
Table 67 File Name Conventions .....	266
Table 68 SYS LED Troubleshooting .....	269
Table 69 ALM LED Troubleshooting .....	269
Table 70 DSL Data Transmission Troubleshooting .....	270
Table 71 ADSL Voice Troubleshooting .....	270
Table 72 Testing In-house Wiring .....	272
Table 73 Local Server Troubleshooting .....	272
Table 74 SYNC-rate Troubleshooting .....	273
Table 75 Configured Settings Troubleshooting .....	273
Table 76 SNMP Server Troubleshooting .....	273
Table 77 Telnet Troubleshooting .....	274
Table 78 Device Specifications .....	279
Table 79 Wire Gauge Specifications .....	280

Table 80 Hardware Telco-50 Connector Port and Pin Numbers ..... 281  
Table 81 Console Cable Connector Pin Assignments ..... 282



# Preface

Congratulations on your purchase of the AAM1212.

This preface discusses the conventions of this User's Guide. It also provides information on other related documentation.

**Note:** Register your product online to receive e-mail notices of firmware upgrades and information at [www.zyxel.com](http://www.zyxel.com) for global products, or at [www.us.zyxel.com](http://www.us.zyxel.com) for North American products.

## About This User's Guide

This manual is designed to guide you through the installation and configuration of your AAM1212 for its various applications.

## Related Documentation









- ZyXEL Glossary and Web Site

Please refer to [www.zyxel.com](http://www.zyxel.com) for an online glossary of networking terms and additional support documentation.

## Syntax Conventions

- “Enter” means for you to type one or more characters. “Select” or “Choose” means for you to use one of the predefined choices.
- Command and arrow keys are enclosed in square brackets. [ENTER] means the Enter, or carriage return key; [ESC] means the Escape key and [SPACE BAR] means the Space Bar.
- Mouse action sequences are denoted using a comma. For example, “In Windows, click **Start**, **Settings** and then **Control Panel**” means first click the **Start** button, then point your mouse pointer to **Settings** and then click **Control Panel**.
- “e.g.,” is a shorthand for “for instance”, and “i.e.,” means “that is” or “in other words”.
- The AAM1212 (ADSL Access Module) may be referred to as “the AAM1212”, “the AAM”, “the ADSL module” or “the DSL module” in this User's Guide.
- The AAM1212-51 is for ADSL over POTS (Annex A) and the AAM1212-53 is for ADSL over ISDN (Annex B). Differentiation is made where needed.

## Graphics Icons Key

AAM-1212 	Computer 	Server 
Computer 	DSLAM 	Gateway 
Central Office/ ISP 	Internet 	Hub/Switch 

## User Guide Feedback

Help us help you. E-mail all User Guide-related comments, questions or suggestions for improvement to [techwriters@zyxel.com.tw](mailto:techwriters@zyxel.com.tw) or send regular mail to The Technical Writing Team, ZyXEL Communications Corp., 6 Innovation Road II, Science-Based Industrial Park, Hsinchu, 300, Taiwan. Thank you.

## Firmware Naming Conventions

A firmware version includes the model code and release number as shown in the following example.

Firmware Version: V3.50(ABA.0), V3.50(ABP.0)

"ABA" or "ABP" is the model code

- "ABA" denotes the AAM1212-51 for ADSL over POTS (Annex A).
- "ABP" denotes the AAM1212-53 for ADSL over ISDN (Annex B).

"0" is this firmware's release number. This varies as new firmware is released. Your firmware's release number may not match what is displayed in this User's Guide.

# CHAPTER 1

## Getting to Know Your AAM1212

This chapter introduces the main features and applications of the AAM.

### 1.1 Introduction

The AAM1212 (ADSL Access Module) is an 12-port ADSL2+ multiplexer network module that aggregates traffic from 12 lines to an Ethernet port and has integrated splitters to allow voice and ADSL to be carried over the same phone line wiring. The hot-swappable AAM1212 is designed to be installed in an IP-based DSLAM (Internet Protocol Digital Subscriber Line Access Multiplexer) chassis such as the IES-1000 (Integrated Ethernet Switch), that connects ADSL subscribers to the Internet.

With its built-in web configurator, managing and configuring the switch is easy. From cabinet management to port-level control and monitoring, you can configure and manage your network via the web browser. In addition, the AAM can also be managed via Telnet, the console port, or third-party SNMP management.

### 1.2 System Description

#### 10/100 Mbps Ethernet Ports

The AAM has two 10/100Mbps auto-negotiating, auto-crossover Ethernet ports. That allow you to:

- Connect the AAM to a second level switch
- Daisy-chain other switches

#### One Telco-50 Connector

There is one Telco-50 connector for ADSL and POTS connection.

#### Stacking

Daisy-chain up to three AAMs (or other Ethernet devices).

#### Integrated Splitters

The integrated DSL splitter eliminates the need to use external splitters that separate the voice-band and ADSL signals.

## Console Port

Use the console port for local management of the AAM.

## IP Protocols

- IP Host (No routing)
- Telnet for configuration and monitoring
- SNMP for management

SNMP MIB II (RFC 1213)

SNMP v1 RFC 1157

SNMPv2, SNMPv2c or later version, compliant with RFC 2011 SNMPv2 MIB for IP, RFC 2012 SNMPv2 MIB for TCP, RFC 2013 SNMPv2 MIB for UDP

Ethernet MIBs RFC 1643

Bridge MIBs (RFC 1493, 2674)

SMI RFC 1155

Multiple Protocols over AAL5 (RFC 1483)

## ADSL Compliance

- Multi-Mode ADSL standard
  - DMT T1.413, issue 2
  - G.DMT (ITU G.992.1) Annex A
  - G.DMT (ITU G.992.1) Annex B
  - G.LITE (ITU G.992.2)
  - ETSI (TS 101 388)
  - G.HS (ITU G.994.1)
- ADSL2
  - G.992.3 Annex A
  - G.992.3 Annex B
  - G.992.3 Annex L, RE-ADSL
  - G.992.3 Annex M
- ADSL2+
  - G.992.5 Annex A
  - G.992.5 Annex B
- Rate adaptation support

## IEEE 802.1p Priority

Your AAM uses IEEE 802.1p Priority to assign priority levels to individual PVCs.

## Multiple PVC and ATM QoS

The AAM allows you to use different channels (also called Permanent Virtual Circuits or PVCs) for different services or subscribers. Define channels on each DSL port for different services or levels of service and assign each channel a priority. ATM Quality of Service (QoS) allows you to regulate the average rate and fluctuations of data transmission. This helps eliminate congestion to allow the transmission of real time data (such as audio and video).

## IEEE 802.1x Port-based Authentication

The AAM supports the IEEE 802.1x standard for centralized user authentication and accounting management through an optional network authentication (RADIUS) server or local user database.

## Management

- Remote configuration backup/restore and firmware upgrade
- SNMP manageable
- Text-based management locally via console port and remotely via telnet
- Editable plain text based configuration file

## Security

- Password protection for system management
- VLAN

## MAC (Media Access Control) Count Filter

You can limit the number of MAC addresses that may be dynamically learned on a port. You may enable/disable the MAC count filter on individual ports.

## Static Multicast Filter

Use the static multicast filter to allow incoming frames based on multicast MAC address(es) that you specify. This feature can be used in conjunction with IGMP snooping to allow multicast MAC address(es) that are not learned by IGMP snooping.

## IGMP Snooping

With IGMP snooping, group multicast traffic is only forwarded to ports that are members of that group. IGMP Snooping generates no additional network traffic, allowing you to significantly reduce multicast traffic passing through your AAM.

## System Monitoring

- System status (link status, rates, statistics counters)
- Temperatures, voltage reports and alarms.

## System Error Logging

The AAM's system error log will record error logs locally. These logs may be viewed again after a warm restart.

## Alarm LED

An **ALM** (alarm) LED lights when the AAM is overheated or the voltage readings are outside the tolerance levels.

## Bandwidth Control

The AAM supports rate limiting in 64Kbps increments allowing you to create different service plans.

## Quality of Service

The AAM has four priority queues so you can ensure mission-critical data gets delivered on time.

Follows the IEEE 802.1p priority setting standard.

# 1.3 Applications

These are the main applications for the AAM:

- Internet access and multimedia services for Multiple Tenant Units (MTU).
- Other applications include telemedicine, surveillance systems, remote servers systems, cellular base stations and high-quality teleconferencing.

## 1.3.1 MTU Application

The following diagram depicts a typical application of the AAM with ADSL modems, in a large residential building, or multiple tenant unit (MTU), that leverages existing phone line wiring to provide Internet access to all tenants. ADSL service can coexist with voice service on the same line.

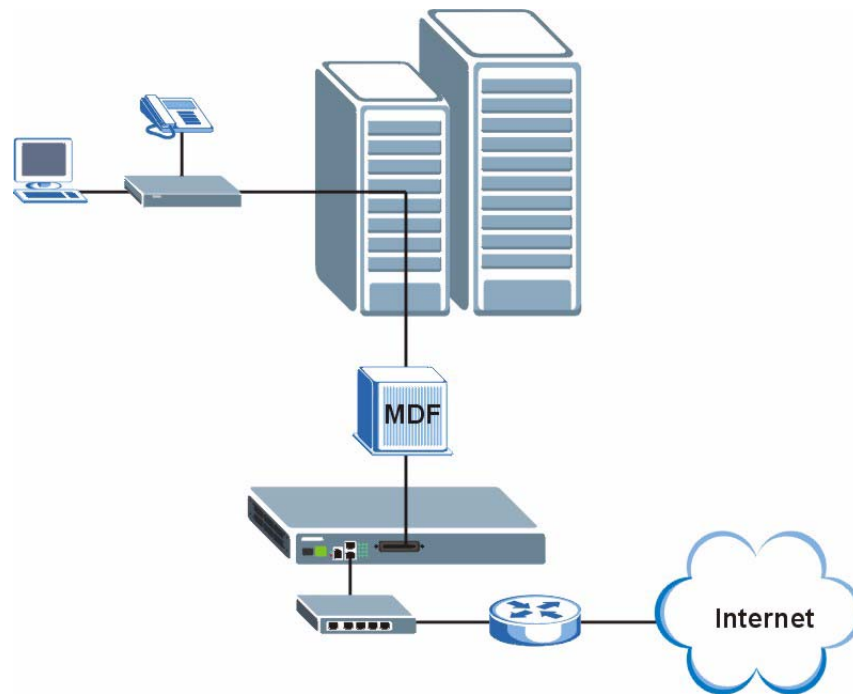
**Figure 1** MTU Application

### 1.3.2 Curbside Application

The AAM can also be used by an Internet Service Provider (ISP) in a street cabinet to form a "mini POP (Point-of-Presence)" to provide broadband services to residential areas that are too far away from the ISP to avail of DSL services. Residents need an ADSL modem, connected as shown in the previous figure.

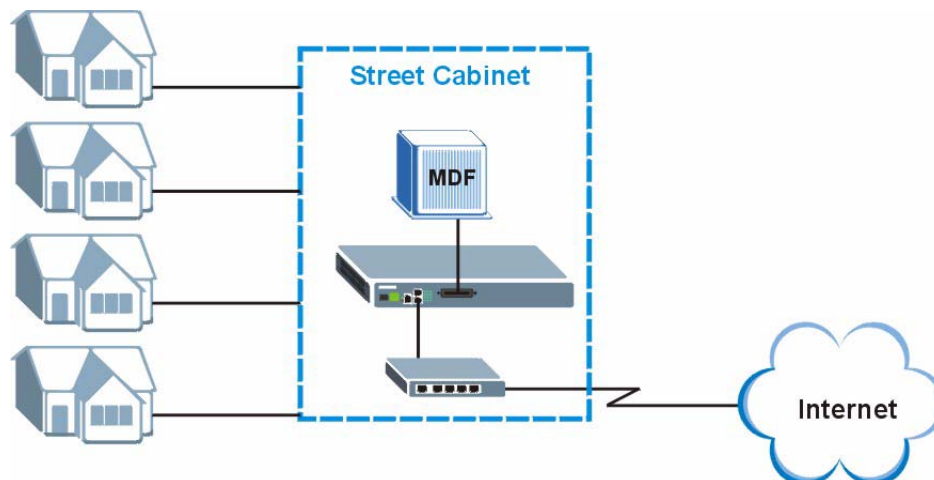
**Figure 2** Curbside Application



# CHAPTER 2

## Removing and Installing the AAM

This chapter shows you how to remove and install the AAM. Each IES-1000 accommodates up to two network modules. Remove and install AAMs via the front of the IES-1000.

### 2.1 Removing the AAM

- 1 Loosen the two screws on the front panel that secure the module to the chassis by turning them counter-clockwise as shown next.

**Figure 3** Loosen Module Screws

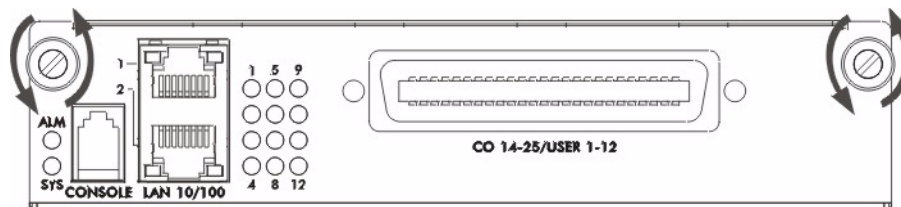

- 2 Gently pull the AAM out of the chassis as shown next.

**Figure 4** Removing the AAM from the IES-1000 Chassis

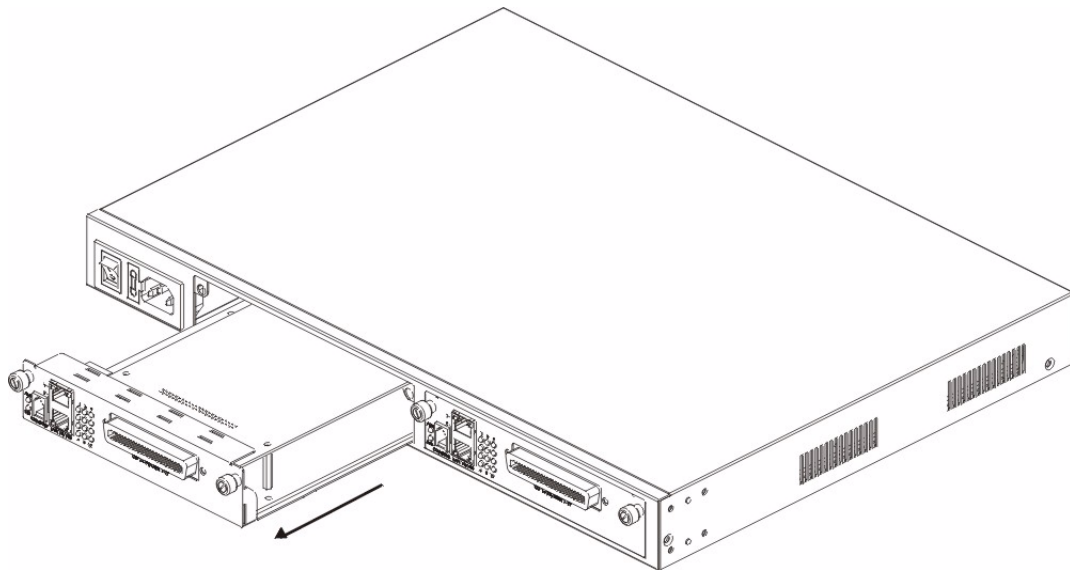

## 2.2 Installing the AAM

- 1 Hold the AAM with the network ports facing you and insert it into an empty slot located on the front of the IES-1000 as shown next.
- 2 Push the AAM in the IES-1000 until the front of the AAM is flush with the IES-1000 chassis.

**Figure 5** Installing the AAM in the IES-1000 Chassis

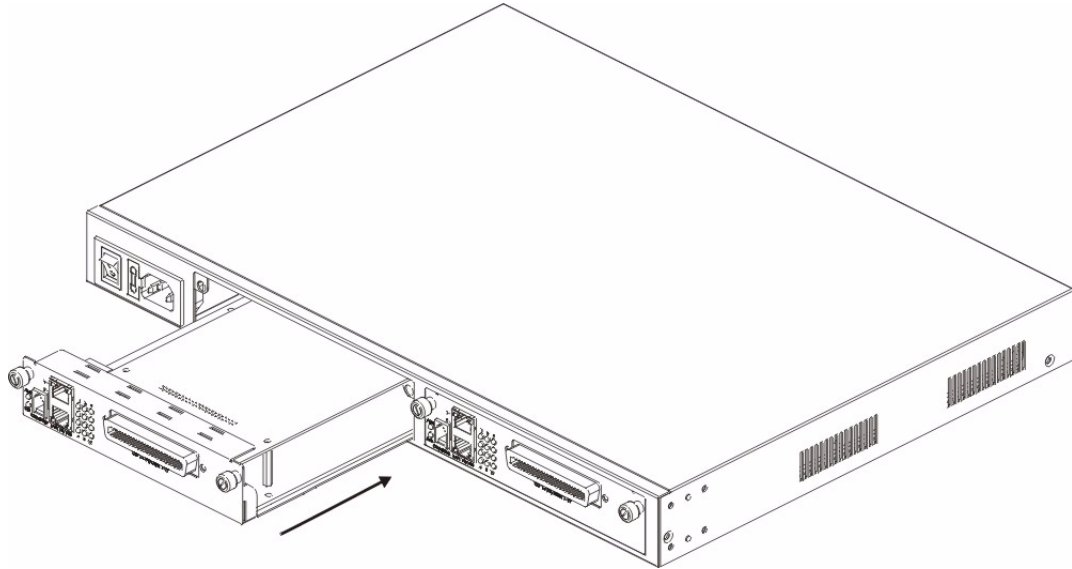

**Note:** The front of the AAM must be flush with the front of the IES-1000 after you install a AAM or it will not work!

- 3 Secure the AAM to the chassis by turning the two screws on the front of the AAM clockwise as shown next.

**Figure 6** Tighten Module Screws

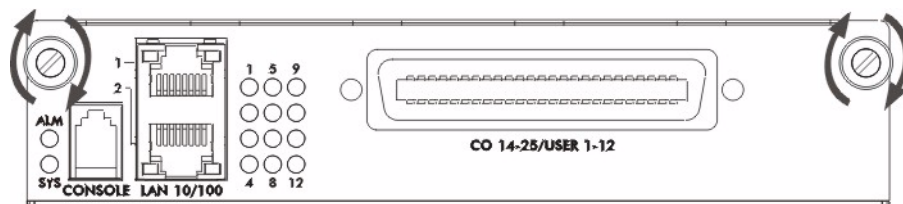

# CHAPTER 3

## Hardware Connections

This chapter describes the front panel and rear panel of the AAM and shows you how to make the hardware connections.

### 3.1 Front Panel

The figure below shows the front panel of the AAM.

**Figure 7** Front Panel

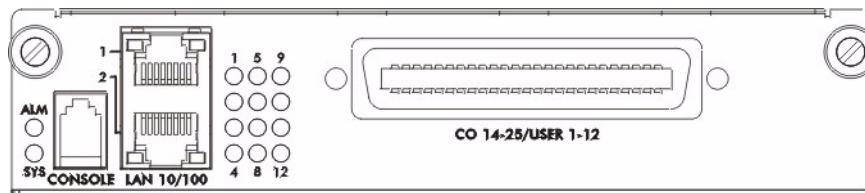

#### 3.1.1 Front Panel Ports

The following table describes the port labels on the front panel.

**Table 1** Front Panel Ports

LABEL	DESCRIPTION
CONSOLE	Only connect this port if you want to configure the AAM using the command line interface (CLI) via the console port.
1, 2 LAN 10/100	Connect these ports to a computer, a hub, an Ethernet switch or router.
CO 14-25/ USER 1-12	Connect the Telco-50 connector <b>USER</b> pins (1-12, 26-37) to subscribers respectively. Connect the Telco-50 connector <b>CO</b> pins (14-25, 39-50) to the telephone company for subscribers respectively.

#### 3.1.2 Front Panel LEDs

The following table describes the LED indicators on the front panel of the AAM.

**Table 2** Front Panel LEDs Description

LED	COLOR	STATUS	DESCRIPTION
ALM	Red	On	There is a hardware failure
		Off	The system is functioning normally

**Table 2** Front Panel LEDs Description (continued)

LED	COLOR	STATUS	DESCRIPTION
SYS	Green	Blinking	The system is rebooting and performing self-diagnostic tests.
		On	The system is on and functioning properly.
		Off	The power is off or the system is not ready/malfunctioning.
1, 2 LAN 10/100	Green	On	The link to a 10 Mbps Ethernet network is up.
		Off	The link to a 10 Mbps Ethernet network is down.
	Yellow	On	The link to a 100 Mbps Ethernet network is up.
		Off	The link to a 100 Mbps Ethernet network is down.
1-12		On	The DSL link is up.
		Off	The DSL link is down.
		Blinking	The AAM is initializing the DSL line.

### 3.1.3 Console Port

For local management, you can use a computer with terminal emulation software configured to the following parameters:

- VT100 terminal emulation
- 9600 bps
- No parity, 8 data bits, 1 stop bit
- No flow control

Connect the male 9-pin end of the console cable to the console port of the AAM. Connect the female end to a serial port (COM1, COM2 or other COM port) of your computer.

#### 3.1.3.1 Default Ethernet Settings

The factory default negotiation settings for the Ethernet ports on the AAM are:

- Speed: Auto
- Duplex: Auto
- Flow control: on

### 3.1.4 LAN Port (Ethernet) Connection

Connect the LAN port of your AAM to an Ethernet WAN switch using a straight-through Category 5 UTP (Unshielded Twisted Pair) cable with RJ-45 connectors.

You may stack multiple IES-1000 units up to the number of ports available on the Ethernet switch as shown next.

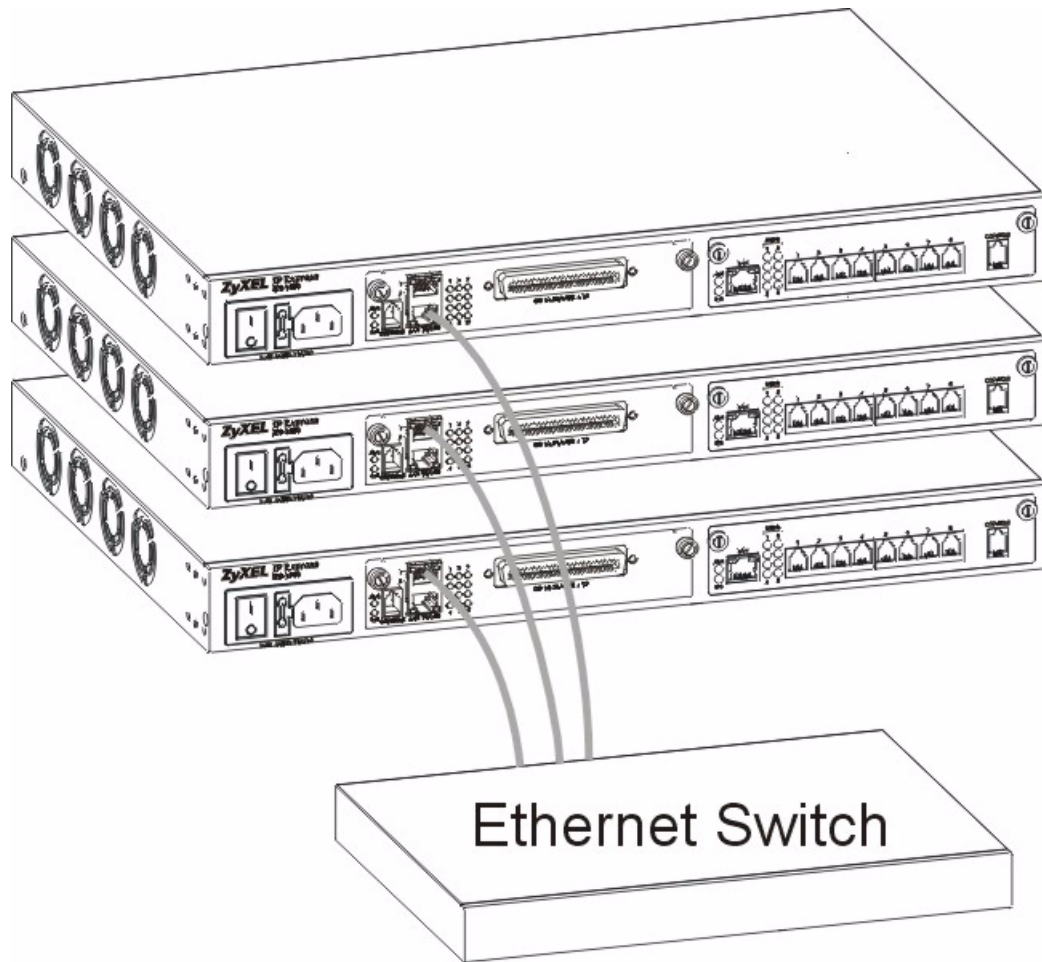
**Figure 8** Stacking Multiple IES-1000 Units

### 3.1.5 Notes About MDFs (Main Distribution Frames)

An MDF is usually installed between end-users' equipment and the telephone company (CO) in a basement or telephone room. The MDF is the point of termination for the outside telephone company lines coming into a building and the telephone lines in the building.

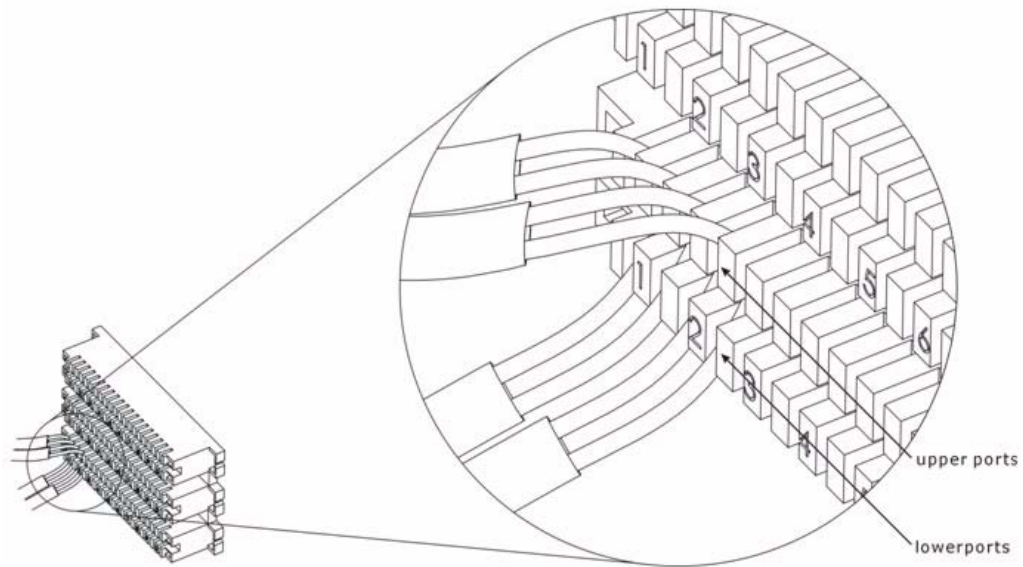
**Figure 9** MDF Wiring

- Connect wiring from end-user equipment to the lower ports of an MDF using a telephone wire. Connect wiring from the telephone company to the upper ports of an MDF (see the previous figure).
- Some MDFs have surge protection circuitry built in between the two banks; thus, do not connect telephone wires from the telephone company directly to the AAM.
- Use a punch-down tool to seat telephone lines between MDF blocks.

### 3.1.6 Telco-50 Cables

Telco-50 cables are used for data and voice applications with MDFs (Main Distribution Frame), patch panels and distribution boxes. They can also be used as extension cables. Telco-50 cables are made up of 25 twisted-pair copper wires.

Connect a Telco-50 connector to one end of the cable (see the hardware specifications appendix for pin assignments) and connect the other end directly to an MDF; alternatively attach RJ-11 connectors and connect directly to DSL modem(s).

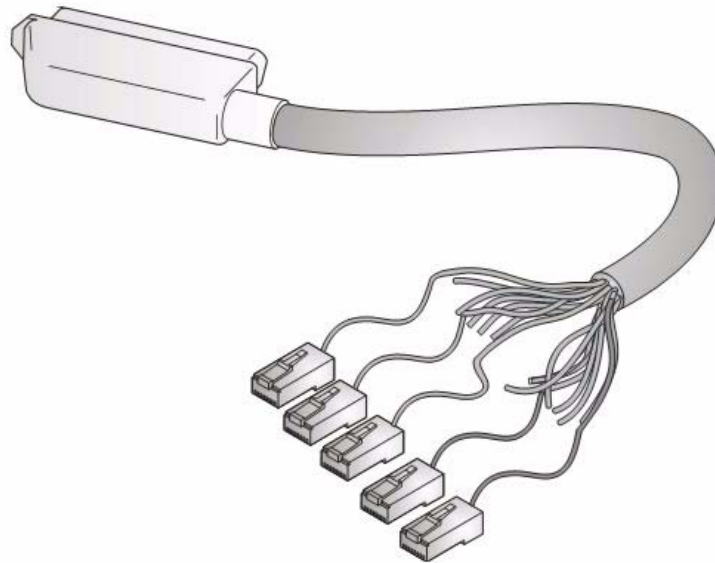
**Figure 10** Telco-50 Cable with RJ-11 Connectors

### 3.1.7 Telco-50 Connections

The internal DSL splitters separate the voice signals from the DSL signals. They feed the DSL signals to the AAM and divert the voice signals to the **CO** lines of the Telco-50 connector.

Connect the **CO** lines of the Telco-50 connector to the PBX or PSTN/ISDN switch.

Connect the **USER** lines of the Telco-50 connector to the subscribers' telephone wiring. In most multi-tenant unit applications, the **USER** pins connect to the subscribers' telephone wiring via Main Distribution Frame (MDF).

See the section on MDF scenarios and the pin assignments in the hardware specifications appendix for details on Telco-50 connections.

### 3.1.8 ADSL Connections

Connect the lines from the user equipment (ADSL modems) to the Telco-50 connector **USER** pins and the lines from the central office switch or PBX (Private Branch Exchange) to the Telco-50 connector **CO** pins. Make sure that the **USER** line and the **CO** lines are not shorted on the MDF (Main Distribution Frame).

The line from the user carries both the ADSL and the voice signals. For each line, the AAM has a built-in splitter that separates the high frequency ADSL signal from the voice band signal and feeds the ADSL signal to the AAM, while the voice band signal is diverted to the **CO** port.

The following figure gives an overview on a possible installation scenario for the AAM. Data and voice signals can coexist on the same telephone wiring.

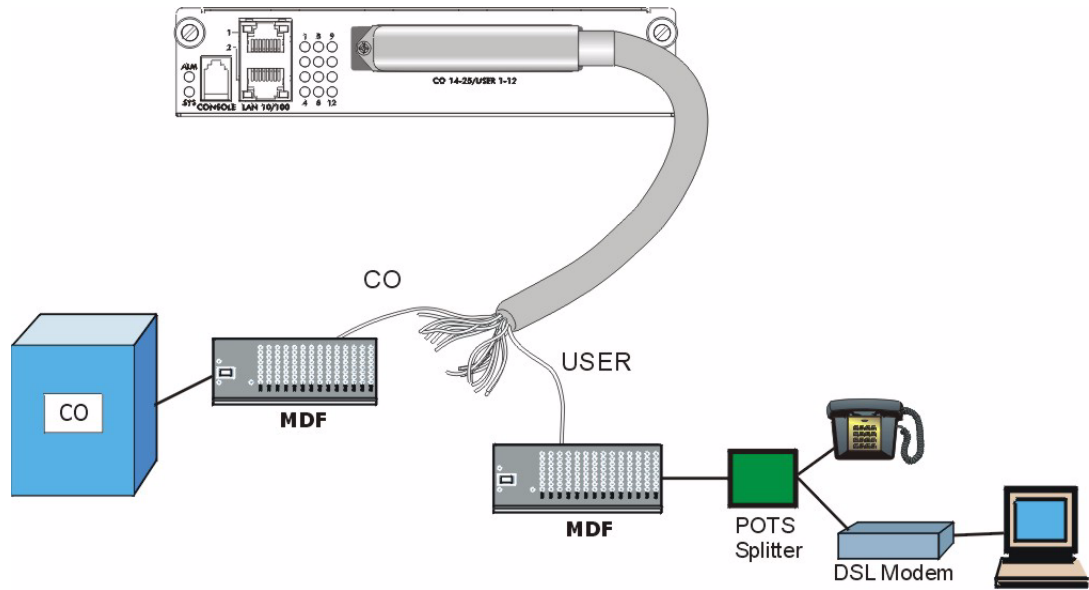
**Figure 11** Installation Overview

**Note:** You can also attach RJ-11 connectors to the Telco-50 cable and connect directly to a DSL modem(s) or patch panel. This chapter discusses connections using MDFs.

### 3.1.9 Typical MDF Scenarios

This section describes typical installation scenarios.

#### 3.1.9.1 Installation Scenario A

You want to install the AAM in an environment where there are no previously installed MDFs. There is no phone service and you want to install the AAM for data-access only. No connections from the CO lines are necessary.

You may connect using an MDF or attach RJ-11 connectors to the non-AAM end of the Telco-50 cable and then connect to DSL modems directly.

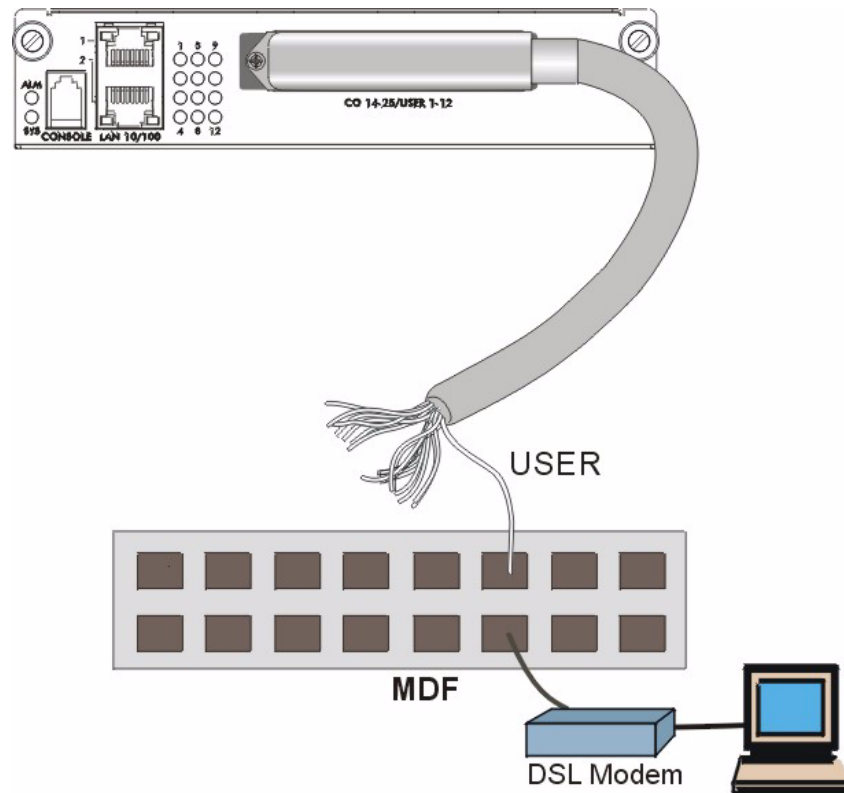
**Figure 12** Installation Scenario A

### 3.1.9.1.1 Procedure To Connect To An MDF

- 1 Connect the Telco-50 connector end of the cable to the Telco-50 connector.
- 2 Connect the USER wiring on the other end of the Telco-50 cable to the upper ports of the MDF using a punch-down tool.
- 3 Connect the telephone wiring from each end-user's DSL modem to the lower ports of the MDF.

### 3.1.9.2 Installation Scenario B

Phone service is available. There is one MDF from which end-users CO connections are made (see next figure).

**Figure 13** One MDF for End-user and CO Connections

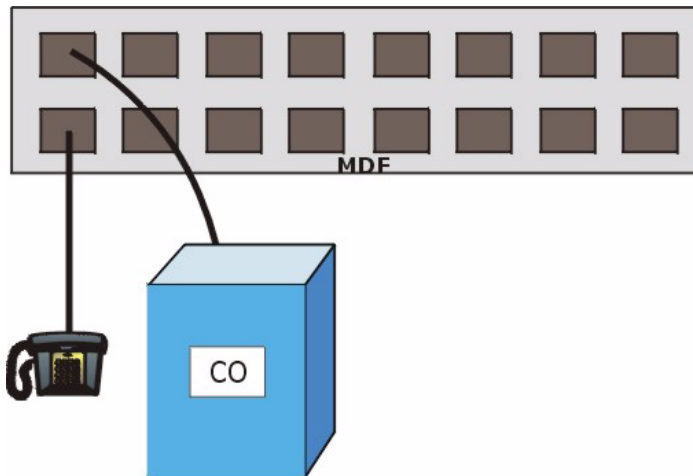

This installation scenario requires three MDFs. Please refer to the following figure for the connection schema.

- MDF 1 is the original MDF used for telephone connections only.
- MDF 2 is used for telephone connections only.
- MDF 3 is for ADSL service connections.

**Note:** Change the wiring (in the following figure) from MDF 1 to MDF 3 for telephone subscribers who want ADSL service.

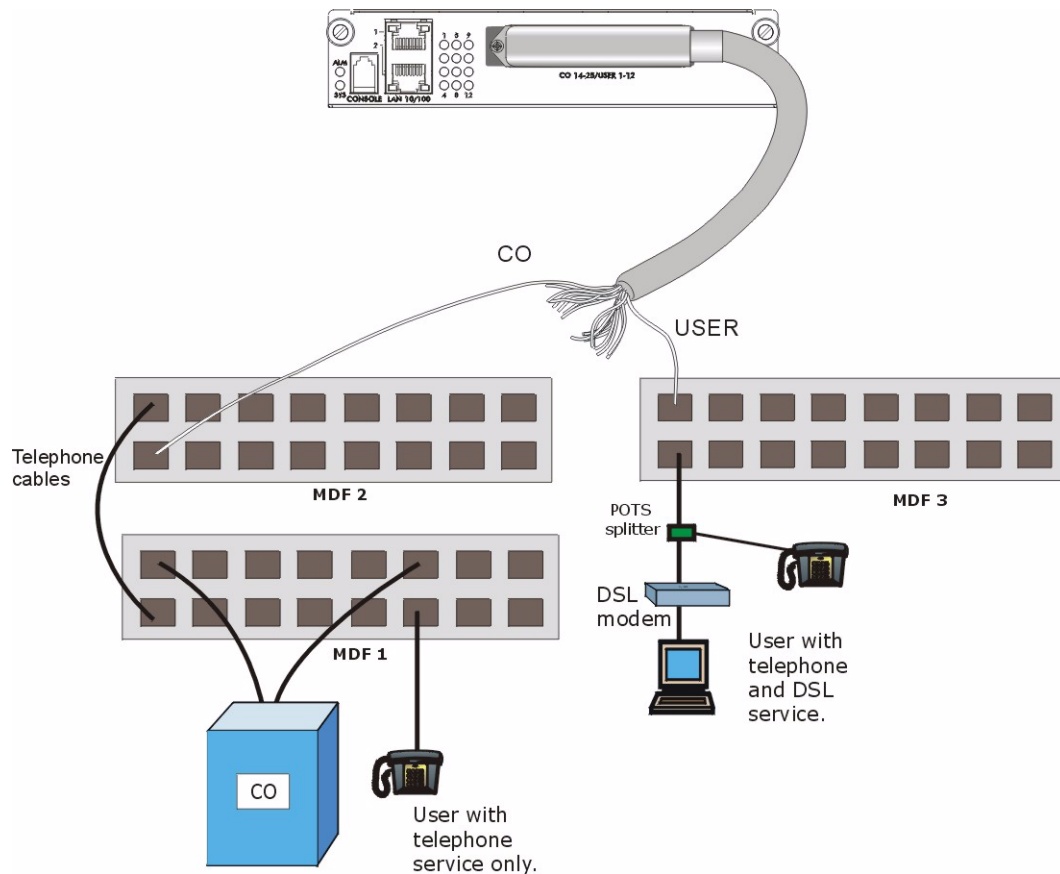
**Figure 14** Installation Scenario B

### 3.1.9.2.1 Procedure To Connect To MDFs

- 1** Connect the Telco-50 connector end of the cable to the Telco-50 connector.
- 2** Connect the **USER** wiring on the other end of the Telco-50 cable to the upper ports of MDF 3 using a punch-down tool.
- 3** Connect the telephone wiring from the end-user's DSL modem(s) to the lower ports of MDF 3.
- 4** Connect the **CO** wiring of the Telco-50 cable to the lower ports of MDF 2 using a punch-down tool.
- 5** Connect the upper ports of MDF 2 to the lower ports of MDF 1 using telephone wires.
- 6** Connect the upper ports of MDF 1 to the telephone company.
- 7** Telephone subscribers only (non-DSL subscribers) retain connections to the lower ports of MDF 1.
- 8** Change the wiring from MDF 1 to MDF 3 for telephone subscribers who want DSL service.

### 3.1.9.3 Installation Scenario C

Phone service is also available but there are two MDFs; one for end-user telephone line connections and the other one for CO telephone wiring connections (see the following figure).

**Note:** Users A and B have telephone (only) service.

**Figure 15** Two Separate MDFs for End-user and CO Connections

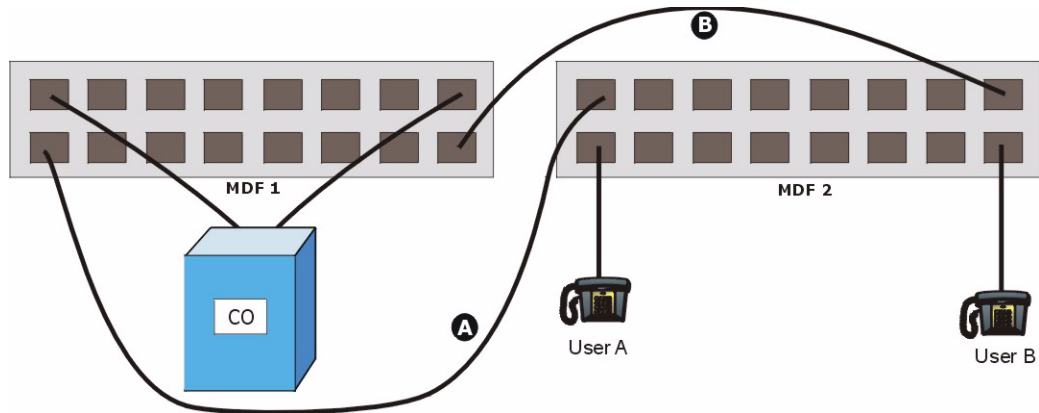

This installation scenario requires four MDFs. Please refer to the following figure for the DSL connection schema.

- MDFs 1 and 2 are the two original MDFs.
- MDFs 3 and 4 are two additional MDFs you need.

**Note:** User A still has telephone service only. User B now has telephone and DSL service (see the following figure).

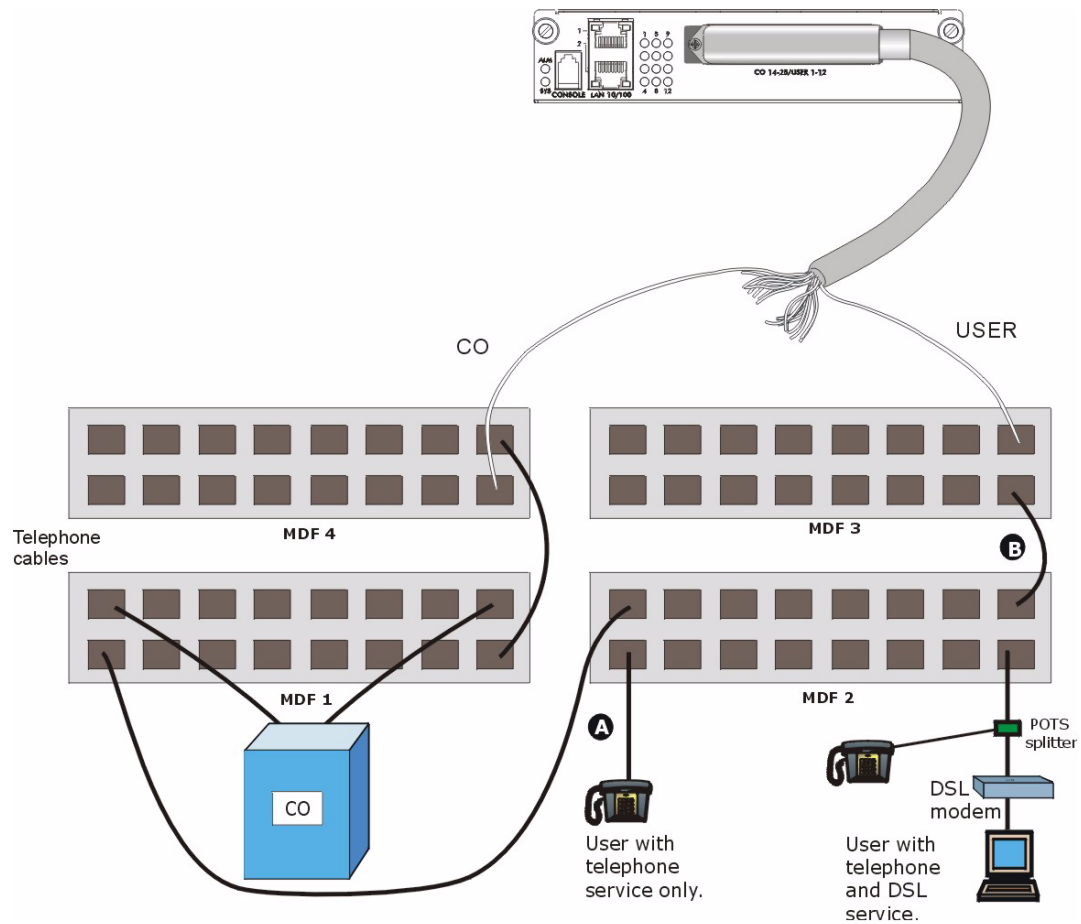
**Figure 16** Installation Scenario C

### 3.1.9.3.1 Procedure To Connect To MDFs

- 1 Connect the Telco-50 connector end of the cable to the Telco-50 connector.
- 2 Connect the **USER** wiring on the other end of the Telco-50 cable to the upper ports of MDF 3 using a punch-down tool.
- 3 Connect the lower ports of MDF 3 to the upper ports of MDF 2 for those users that want DSL service. (Users who want telephone service only, retain the original connection from the top port of MDF 2 to the bottom port of MDF 1.)
- 4 Connect the telephone wiring from the end-user's DSL equipment to the lower ports of MDF 2.
- 5 Connect the **CO** wiring of the Telco-50 cable to the lower ports of MDF 4 using a punch-down tool.
- 6 Connect the top ports of MDF 4 to the bottom ports of MDF 1 using telephone wires.
- 7 Connect the top ports of MDF 1 to the telephone company.



# CHAPTER 4

## Web Configurator Introduction

This chapter tells how to access and navigate the web configurator.

### 4.1 Web Configurator Overview

The web configurator allows you to use a web browser to manage the AAM.

### 4.2 Accessing the Web Configurator

The web configurator is an HTML-based management interface that allows easy AAM setup and management via Internet browser. Use Internet Explorer 6.0 and later versions. The recommended screen resolution is 1024 by 768 pixels.

In order to use the web configurator you need to allow:

- Web browser pop-up windows from your device. Web pop-up blocking is enabled by default in Windows XP SP (Service Pack) 2.
- JavaScripts (enabled by default).
- Java permissions (enabled by default).

#### 4.2.1 Password

- 1** Launch your web browser and enter the IP address of the AAM ("192.168.1.1" is the factory default) in the **Location** or **Address** field. Press **Enter**.
- 2** The **Password** screen appears. Type "admin" in the user name field and your password (factory default "1234") in the password field. Click **OK**.

**Figure 17** Login Screen



### 4.3 Home Screen

This is the web configurator's **Home** screen.

**Figure 18** Home Screen

**ZyXEL**

Home

System Up Time: 2(days) : 17:19:27

ENET	Status	Port Name	Media	Duplex	Up Time
1	Up	enet1	100copper	full duplex	65:19:26
2	Down	enet2	-	-	--:--:--

xDSL	Status	Mode	Up/Down stream	Interleave/Fast	Up Time
1	Down	-	-/-	-	-
2	Down	-	-/-	-	-
3	Down	-	-/-	-	-
4	Down	-	-/-	-	-
5	Down	-	-/-	-	-
6	Down	-	-/-	-	-
7	Down	-	-/-	-	-
8	Down	-	-/-	-	-
9	Down	-	-/-	-	-
10	Down	-	-/-	-	-
11	Down	-	-/-	-	-
12	Down	-	-/-	-	-

Poll Interval (s)

Port

Navigation Panel

Click **Home** to view current device statistics.

Click **Logout** to exit the web configurator.

In the navigation panel, click a main link to reveal a list of submenu links. Click a submenu link to go to the corresponding screen.

**Table 3** Navigation Panel Sub-links Overview

		
Management	Config Save	
		

The following table briefly describes the functions of the screens that you open by clicking the navigation panel's sub-links.

**Table 4** Web Configurator Screens

LINK	DESCRIPTION
Basic Settings	
System Info	Use this screen to display general system and hardware monitoring information.
General Setup	Use this screen to configure general identification information about the AAM and the time and date settings.

**Table 4** Web Configurator Screens (continued)

LINK	DESCRIPTION
Switch Setup	Use this screen to set up global switch parameters such as IGMP snooping, MAC address learning, GARP and priority queues.
IP Setup	Use this screen to configure the system and management IP addresses and subnet masks.
ENET Port Setup	Use this screen to configure settings for the Ethernet ports.
xDSL Port Setup	Use this screen to go to screens for configuring settings for individual DSL ports.
xDSL Profiles Setup	Use this screen to go to screens for configuring profiles for the DSL ports.
xDSL Line Data	Use this screen to go to screens for viewing DSL line operating values, bit allocation and performance counters.
Advanced Application	
VLAN	Use this screen to go to screens for viewing and configuring the VLAN settings.
IGMP Snooping	Use this screen to configure IGMP snooping and display the results.
Static Multicast	Use this screen to configure static multicast filter entries.
Filtering	Use this screen to configure packet filtering.
MAC Filter	Use this screen to configure MAC filtering for each port.
Spanning Tree Protocol	Use this screen to go to screens for displaying Rapid Spanning Tree Protocol (RSTP) information and configuring RSTP settings.
Port Authentication	Use this screen to go to screens for configuring RADIUS and IEEE 802.1x security settings.
Port Security	Use this screen to limit the number of MAC address that can be learned on a port.
DHCP Relay	Use this screen to configure the DHCP relay settings.
Syslog	Use this screen to configure the syslog settings.
Access Control	Use this screen to configure the system login password and configure SNMP and remote management.
Routing Protocol	
Static Routing	Use this screen to configure static routes. A static route defines how the AAM should forward traffic by configuring the TCP/IP parameters manually.
Management	
Maintenance	Use this screen to perform firmware and configuration file maintenance as well as restart the system.
Diagnostic	Use this screen to view system logs and test port(s).
MAC Table	Use this screen to view the MAC addresses (and types) of devices attached to what ports and VLAN IDs.
ARP Table	Use this screen to view the MAC address to IP address resolution table.
Config Save	
Config Save	Use this screen to save the device's configuration into the nonvolatile memory (the AAM's storage that remains even if the AAM's power is turned off).

## 4.4 Saving Your Configuration

Click **Apply** in a configuration screen when you are done modifying the settings in that screen to save your changes back to the run time memory. Settings in the run time memory are lost when the AAM's power is turned off.

Click **Config Save** in the navigation panel and then the **Save** button to save your configuration to nonvolatile memory. Nonvolatile memory refers to the AAM's storage that remains even if the AAM's power is turned off.

**Note:** Use **Config Save** when you are done with a configuration session.

## 4.5 Changing Your Password

After you log in for the first time, it is recommended you change the default Administrator password in the **Logins** screen. Click **Advanced Application**, **Access Control** and then **Logins** to display the next screen.

**Figure 19** Web Configurator: Change Password

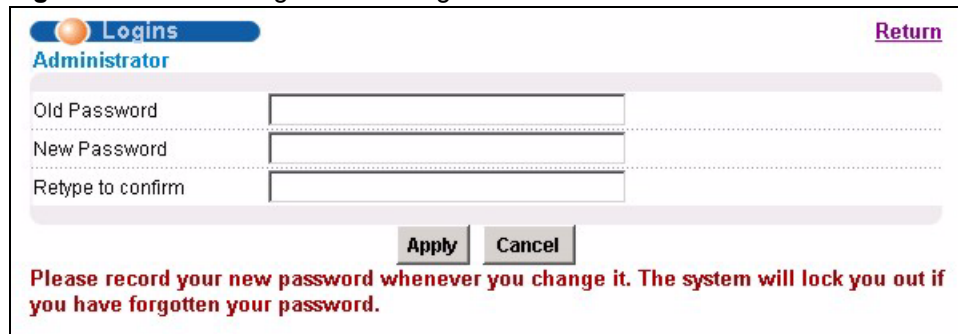

The screenshot shows the 'Logins' section of the Web Configurator. At the top left, there is a blue header with an orange circle icon and the text 'Logins'. Below this, the word 'Administrator' is displayed. To the right of the header is a purple 'Return' link. The main area contains three input fields: 'Old Password', 'New Password', and 'Retype to confirm'. Below these fields are two buttons: 'Apply' and 'Cancel'. At the bottom, there is a red warning message: 'Please record your new password whenever you change it. The system will lock you out if you have forgotten your password.'

## 4.6 Logging Out of the Web Configurator

Click **Logout** in a screen to exit the web configurator. You have to log in with your password again after you log out. This is recommended after you finish a management session both for security reasons and so you don't lock out other AAM administrators.

**Figure 20** Web Configurator: Logout Screen





# CHAPTER 5

## Initial Configuration

This chapter describes initial configuration for the AAM.

### 5.1 Initial Configuration Overview

This chapter shows what you first need to do to provide service to ADSL subscribers.

### 5.2 Initial Configuration

This chapter uses the web configurator for initial configuration. See the commands part of this User's Guide for information on the commands. Use Internet Explorer 6 and later versions with JavaScript enabled.

- 1 Make sure your computer is in the same subnet as the AAM's default IP address (192.168.1.1) and subnet mask (255.255.255.0).
- 2 Launch your web browser and type "192.168.1.1" in the **Location** or **Address** field. Press **Enter**.
- 3 The **Enter Network Password** screen appears. Type "admin" in the user name field and your password (factory default "1234") in the password field. Click **OK**.

**Figure 21** Login Screen

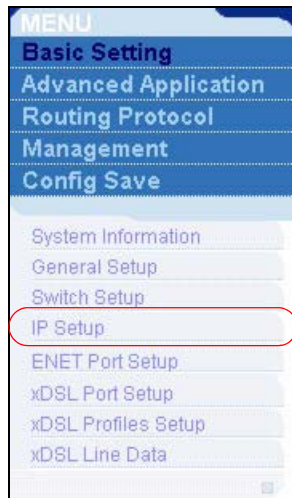

- 4 Click **Basic Setting** and then **IP Setup**.

**Figure 22** Basic Setting IP Setup Menu

- 5 Use this screen to change the IP address, subnet mask, and default gateway IP address for your network. Apply the settings. If you change the AAM's IP address, you must use the new IP address if you want to access the web configurator again.

**Figure 23** IP setup

- 6 Skip to step 15 if you have your subscribers use VPI 0 and VCI 33 (the default for all of the ADSL ports). Otherwise, use the following steps to change the VPI and VCI settings for all of the ADSL ports.

First you will delete the default virtual channel from all of the ADSL ports (you cannot edit it).

Adding another virtual channel without deleting the default virtual channel is not recommended since you cannot set the new channel to be the port's super channel. The super channel can forward frames belonging to multiple VLAN groups (that are not assigned to other channels). A channel that is not the super channel can only forward frames with a single VLAN ID (that is configured on that channel). The AAM would drop any frames received from the subscriber that are tagged with another VLAN ID.

Then you will configure a new virtual channel for a port and copy it to the other ADSL ports

- 7 Under **Basic Setting**, click **xDSL Port Setup**.

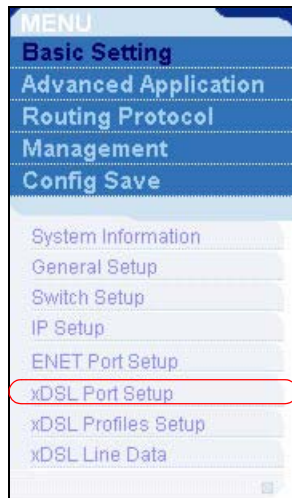
**Figure 24** Basic Setting xDSL Port Setup Menu

**8** Click **VC Setup**.

**Figure 25** xDSL Port Setup

Port	Active	Customer Info	Customer Tel	Profile	Mode	Channels
1	enabled			DEFVAL	auto	1
2	enabled			DEFVAL	auto	1
3	enabled			DEFVAL	auto	1
4	enabled			DEFVAL	auto	1
5	enabled			DEFVAL	auto	1
6	enabled			DEFVAL	auto	1
7	enabled			DEFVAL	auto	1
8	enabled			DEFVAL	auto	1
9	enabled			DEFVAL	auto	1
10	enabled			DEFVAL	auto	1
11	enabled			DEFVAL	auto	1
12	enabled			DEFVAL	auto	1

**9** Click a virtual channel's **Select** radio button and click **Delete**. Click **OK** in the next screen.

**Figure 26** Deleting a PVC

The screenshot shows the 'VC Setup' configuration page. At the top, there are fields for Port (1), VPI (0), VC Profile (DEFVAL), PVID (1), Super Channel (unchecked), VCI (0), and Priority (0). Below these are 'Add' and 'Cancel' buttons. A 'Show Port' dropdown is set to 'ALL'. A table lists 12 ports with columns for Index, Port, VPI/VCI, VC Profile, PVID, Priority, and a 'Select' column. The 'Select' column for port 1 has a radio button selected and is circled in red. At the bottom, a 'Delete' button is also circled in red, with the text 'Index 1 selected' to its left.

Index( Click to modify)	Port	VPI/ VCI	VC Profile	PVID	Priority	Select
1	1	0/ 33	DEFVAL	0	0	<input checked="" type="radio"/>
2	2	0/ 33	DEFVAL	0	0	<input type="radio"/>
3	3	0/ 33	DEFVAL	0	0	<input type="radio"/>
4	4	0/ 33	DEFVAL	0	0	<input type="radio"/>
5	5	0/ 33	DEFVAL	0	0	<input type="radio"/>
6	6	0/ 33	DEFVAL	0	0	<input type="radio"/>
7	7	0/ 33	DEFVAL	0	0	<input type="radio"/>
8	8	0/ 33	DEFVAL	0	0	<input type="radio"/>
9	9	0/ 33	DEFVAL	0	0	<input type="radio"/>
10	10	0/ 33	DEFVAL	0	0	<input type="radio"/>
11	11	0/ 33	DEFVAL	0	0	<input type="radio"/>
12	12	0/ 33	DEFVAL	0	0	<input type="radio"/>

**10** Click **All** and then **Apply**.

**Figure 27** Select Ports

The screenshot shows a dialog box titled 'Please select ports and click apply button.' with a 'select' label and two buttons: 'All' and 'None', which are circled in red. Below the buttons are 'Apply' and 'Cancel' buttons. The dialog also shows a grid of checkboxes for ports 0-9 and 10-12, with '1-9' and '10-12' rows checked.

**11** Select **Super Channel** to allow the channel to forward frames belonging to multiple VLAN groups (that are not assigned to other channels). Enter the VPI and VCI that you need. Leave the other default settings and click **Add**.

**Figure 28** Adding a New Channel

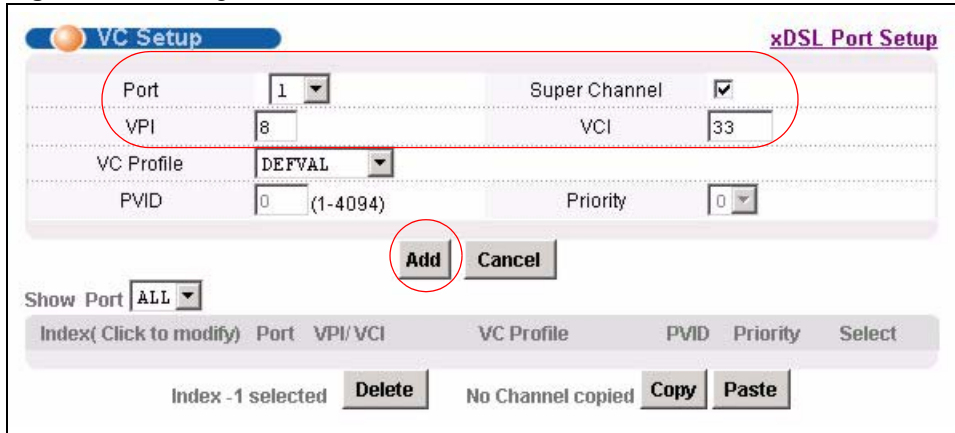

**12** Click the new channel's **Select** radio button. Click **Copy** and then **Paste**.

**Figure 29** Copying the PVC

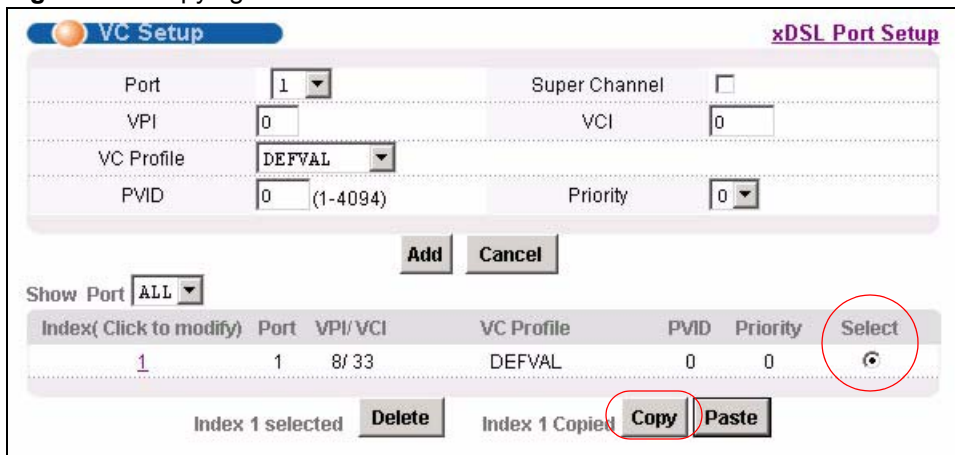

**13** Click **All** to select every port.

**14** Click **Apply** to paste the settings.

**Figure 30** Select Ports

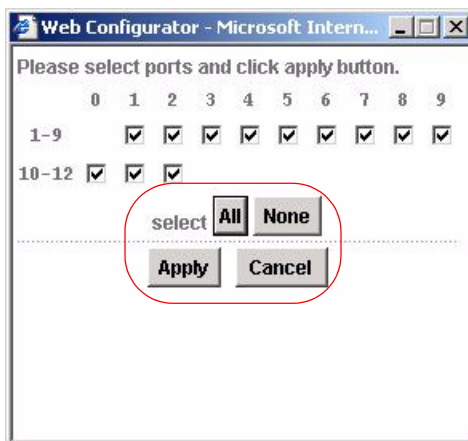

**15** Click **Config Save** and **Config Save**.

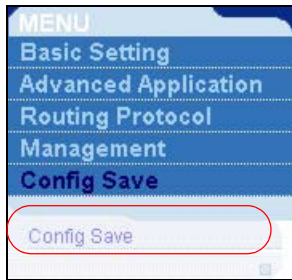
**Figure 31** Config Save Menu

**16** Click Save.

**Figure 32** Config Save Screen

You can now use the device (with the other settings set to the defaults) to provide service to ADSL subscribers. See the rest of this chapter for information on other default settings.

## 5.3 Default Settings

This table lists major default settings.

**Table 5** Default Settings

<b>VLAN Default Settings</b>		
One VLAN is created (this is also the management VLAN).		
VID:	1	
Registration	Fixed for the Ethernet and ADSL ports	
Tagging:	Untagged for all ports	
<b>STP Default Settings</b>		
Enable/Disable State:	Disabled	
Operational Mode:	auto	
<b>(ADSL) Port Profile Default Settings</b>		
Name:	DEFVAL	
Profile Status:	Active	
Latency Mode:	Interleave	
	Upstream ADSL Settings:	Downstream ADSL Settings:
Max Rate	512 Kbps	2048 Kbps
Min Rate	64 Kbps	64 Kbps
Interleave Delay	4 ms (AAM1212-51) 20 ms (AAM1212-53)	4 ms (AAM1212-51) 20 ms (AAM1212-53)
Max SNR	31 db	31 db

**Table 5** Default Settings

Min SNR	0 db	0 db
Target SNR	6 db	6 db
Name:	DEFVAL_MAX	
Profile Status:	Active	
Latency Mode:	Interleave	
	Upstream ADSL Settings:	Downstream ADSL Settings:
Max Rate	512 Kbps	9088 Kbps
Min Rate	64 Kbps	64 Kbps
Interleave Delay	4 ms (AAM1212-51) 20 ms (AAM1212-53)	4 ms (AAM1212-51) 20 ms (AAM1212-53)
Max SNR	31 db	31 db
Min SNR	0 db	0 db
Target SNR	6 db	6 db
<b>Virtual Channel Default Settings<sup>a</sup></b>		
Super channel:	Enabled	
VPI:	0	
VCI:	33	
VC Profile:	DEFVAL	
<b>Default VC Profile Settings</b>		
DEFVAL Profile Settings		
Encapsulation:	RFC 1483	
Multiplexing:	LLC-based	
Traffic Class:	UBR	
PCR:	300000 Kbps	
CDVT:	0	
DEFVAL_VC Profile Settings		
Encapsulation:	RFC 1483	
Multiplexing:	VC-based	
Traffic Class:	UBR	
PCR:	300000 Kbps	
CDVT:	0	
<b>Default IGMP Filter Profile Settings</b>		
The <b>DEFVAL</b> IGMP filter profile is assigned to all of the ADSL ports by default. It allows a port to join all multicast IP addresses (224.0.0.0~239.255.255.255).		

a. The AAM ADSL ports' PVCs use ATM Adaptation Layer (AAL) 5.



# CHAPTER 6

## Home and Port Statistics Screens

This chapter describes the **Home** (status) and **Port Statistics** screens.

### 6.1 Home and Port Statistics Screens Overview

The **Home** screen of the web configurator displays a port statistical summary with links to each port for showing statistical details.

### 6.2 Home Screen

To view the port statistics, click **Home** in any web configurator screen to display the **Home** screen as shown next.

**Figure 33** Home

**Home**  
System Up Time: 0(days) : 0:25:01

ENET	Status	Port Name	Media	Duplex	Up Time
<a href="#">1</a>	Up	enet1	100copper	full duplex	0:25:0
<a href="#">2</a>	Up	enet2	100copper	full duplex	0:25:0

xDSL	Status	Mode	Up/ Down stream	Interleave/ Fast	Up Time
<a href="#">1</a>	Up	adsl2+	510 / 2045	Interleave	0:24:28
<a href="#">2</a>	Down	-	- / -	-	-
<a href="#">3</a>	Down	-	- / -	-	-
<a href="#">4</a>	Down	-	- / -	-	-
<a href="#">5</a>	Down	-	- / -	-	-
<a href="#">6</a>	Down	-	- / -	-	-
<a href="#">7</a>	Down	-	- / -	-	-
<a href="#">8</a>	Down	-	- / -	-	-
<a href="#">9</a>	Down	-	- / -	-	-
<a href="#">10</a>	Down	-	- / -	-	-
<a href="#">11</a>	Down	-	- / -	-	-
<a href="#">12</a>	Down	-	- / -	-	-

Poll Interval(s)

Port

The following table describes the labels in this screen.

**Table 6** Home

<b>LABEL</b>	<b>DESCRIPTION</b>
System up Time	This field shows how long the system has been running since the last time it was started.
The following fields are related to the Ethernet ports.	
ENET	This field displays the number of the Ethernet port. Click a port number to display that port's statistics screen (refer to 9.2.1).
Port Name	This field displays the name of the Ethernet port.
Media	This field displays the speed and the type of media that this Ethernet port is using for a connection ( <b>100copper</b> or <b>10copper</b> ). "-" displays when the port is disabled or not connected.
Duplex	This field displays whether the port is using half or full-duplex communication. "-" displays when the port is disabled or not connected.
Up Time	This field shows the total amount of time in hours, minutes and seconds the port's connection has been up. "--:--:--" displays when the port is disabled or not connected.
The following fields are related to the ADSL ports.	
xDSL	This identifies the ADSL port. Click a port number to display the <b>ADSL Port Statistics</b> screen (refer to <a href="#">Section 6.2.2 on page 67</a> ).
Status	This field shows whether the port is connected ( <b>Up</b> ) or not ( <b>Down</b> ).
Mode	This field shows which ADSL operational mode the port is set to use. "-" displays when the port is not connected.
Up/Down stream	This field shows the number of kilobytes per second that a port is set to transmit and receive.
Interleave/Fast	This field shows the port's ADSL latency mode (fast or interleave).
Up Time	This field shows the total amount of time in hours, minutes and seconds the port's connection has been up. "-" displays when the port is not connected.
The following fields and buttons apply to the whole screen.	
Poll Interval(s)	The text box displays how often (in seconds) this screen refreshes. You may change the refresh interval by typing a new number in the text box and then clicking <b>Set Interval</b> .
Stop	Click <b>Stop</b> to halt system statistic polling.
Clear Counter	Select a port from the <b>Port</b> drop-down list box and then click <b>Clear Counter</b> to erase the recorded statistical information for that port.

## 6.2.1 Ethernet Port Statistics

In the **Home** screen, click an Ethernet port's number to display that port's statistics screen as shown next.

**Figure 34** Ethernet Port Statistics

Port Name	enet1		
Rx bytes	64129	Rx packets	460
Rx error fcs	0	Rx multicast	45
Rx broadcast	199	Rx mac pause	0
Rx fragments	0	Rx error overrun	0
Rx error mru	0	Rx dropped	0
Rx jabber	0	Rx error alignment	0
Rx oversize	0	Rx undersize	0
Rx discard	0		
Tx bytes	185682	Tx packets	276
Tx multicast	0	Tx broadcast	0
Tx mac_pause	0	Tx fragments	0
Tx frames	276	Tx error underrun	0
Tx undersize	0	Tx jabber	0
Tx oversize	0		
packet(<=64)	244	packet(65-127)	221
packet(128-255)	60	packet(256-511)	87
packet(512-1023)	22	packet(1024-1518)	102
packet(1522)	0		
packet(total)	736	broadcast(total)	199
multicast(total)	45	octet(total)	249811

Poll Interval( s)

Port

The following table describes the labels in this screen.

**Table 7** Ethernet Port Statistics

LABEL	DESCRIPTION
Return	Click this link to go back to the <b>Home</b> screen.
Port	Use this drop-down list box to select a port for which you wish to view statistics. This field identifies the port described in this screen.
Port Name	This field displays the name that you have configured for the port.
Rx bytes	This field shows the number of octets of Ethernet frames received that are from 0 to 1518 octets in size, counting the ones in bad packets, not counting framing bits but counting FCS (Frame Check Sequence) octets. An octet is an 8-bit binary digit (byte).
Rx packets	This field shows the number of packets received on this port (including multicast, unicast, broadcast and bad packets).
Rx error fcs	This field shows the number of frames received with an integral length of 64 to 1518 octets and containing a Frame Check Sequence error.
Rx multicast	This field shows the number of good multicast frames received of 64 to 1518 octets in length (for non VLAN) or 1522 octets (for VLAN), not including Broadcast frames. Frames with range or length errors are also not taken into account.
Rx broadcast	This field shows the number of good broadcast frames received of 64 to 1518 octets in length (for non VLAN) or 1522 octets (for VLAN), not including multicast frames. Frames with range or length errors are also not taken into account.

**Table 7** Ethernet Port Statistics (continued)

LABEL	DESCRIPTION
Rx mac pause	This field shows the number of valid IEEE 802.3x Pause frames received on this port.
Rx fragments	This field shows the number of frames received that were less than 64 octets long, and contained an invalid FCS, including non-integral and integral lengths.
Rx error overrun	This field shows how many times an Ethernet transmitter overrun occurred.
Rx error mru	This field shows the number of received frames that were dropped due to exceeding the Maximum Receive Unit frame size.
Rx dropped	This field shows the number of received frames that were steamed into the AAM, but later dropped because of a lack of system resources.
Rx jabber	This field shows the number of frames received that were longer than 1518 octets (non VLAN) or 1522 octets (VLAN) and contained an invalid FCS, including alignment errors.
Rx error alignment	This field shows the number of frames received that were 64 to 1518 (non VLAN) or 1522 (VLAN) octets long but contained an invalid FCS and a non-integral number of octets.
Rx oversize	This field shows the number of frames received that were bigger than 1518 (non VLAN) or 1522 (VLAN) octets and contained a valid FCS.
Rx undersize	This field shows the number of frames received that were less than 64 octets long and contained a valid FCS.
Rx discard	This field shows the number of frames dropped based on packet filtering.
Tx bytes	This field shows the number of bytes that have been transmitted on this port. This includes collisions but not jam signal or preamble/SFD (Start of Frame Delimiter) bytes.
Tx packets	This field shows the number of packets transmitted on this port.
Tx multicast	This field shows the number of good multicast frames transmitted on this port (not including broadcast frames).
Tx broadcast	This field shows the number of broadcast frames transmitted on this port (not including multicast frames).
Tx mac_pause	This field shows the number of valid IEEE 802.3x Pause frames transmitted on this port.
Tx fragments	This field shows the number of transmitted frames that were less than 64 octets long, and with an incorrect FCS value.
Tx frames	This field shows the number of complete good frames transmitted on this port.
Tx error underrun	This field shows the number of outgoing frames that were less than 64 octets long.
Tx undersize	This field shows the number of frames transmitted that were less than 64 octets long and contained a valid FCS.
Tx jabber	This field shows the number of frames transmitted that were longer than 1518 octets (non VLAN) or 1522 octets (VLAN) and contained an incorrect FCS value.
Tx oversize	This field shows the number of frames transmitted that were bigger than 1518 octets (non VLAN) or 1522 (VLAN) and contained a valid FCS.
packet(<=64)	This field shows the number of frames received and transmitted (including bad frames) that were 64 octets or less in length (this includes FCS octets but excludes framing bits).
packet(65-127)	This field shows the number of frames received and transmitted (including bad frames) that were 65 to 127 octets in length (this includes FCS octets but excludes framing bits).

**Table 7** Ethernet Port Statistics (continued)

<b>LABEL</b>	<b>DESCRIPTION</b>
packet(128-255)	This field shows the number of frames received and transmitted (including bad frames) that were 128 to 255 octets in length (this includes FCS octets but excludes framing bits).
packet(256-511)	This field shows the number of frames received and transmitted (including bad frames) that were 256 to 511 octets in length (this includes FCS octets but excludes framing bits).
packet(512-1023)	This field shows the number of frames received and transmitted (including bad frames) that were 512 to 1023 octets in length (this includes FCS octets but excludes framing bits).
packet(1024-1518)	This field shows the number of frames received and transmitted (including bad frames) that were 1024 to 1518 octets in length (this includes FCS octets but excludes framing bits).
packet(1522)	This field shows the number of frames received and transmitted (including bad frames) that were 1519 to 1522 octets in length (this includes FCS octets but excludes framing bits).
packet(total)	This field shows the total number of received and transmitted packets.
broadcast(total)	This field shows the total number of received and transmitted broadcast frames.
multicast(total)	This field shows the total number of received and transmitted multicast frames.
octet(total)	This field shows the total number of received and transmitted octets (unicast, multicast and broadcast).
Poll Interval(s)	The text box displays how often (in seconds) this screen refreshes. You may change the refresh interval by typing a new number in the text box and then clicking <b>Set Interval</b> .
Stop	Click <b>Stop</b> to halt system statistic polling.
Clear Counter	Select a port from the <b>Port</b> drop-down list box and then click <b>Clear Counter</b> to erase the recorded statistical information for that port.

## 6.2.2 ADSL Port Statistics

In the **Home** screen, click an ADSL port's number to display that port's statistics screen as shown next.

**Figure 35** ADSL Port Statistics

**Port Statistics** [Return](#)

xDSL Port: 1

Port Name	
Tx packets	6355
Rx packets	0
Tx broadcast packets	6351
Rx broadcast packets	0
Tx discard packets	0
Rx discard packets	0
Errors	0
Tx rate	304
Rx rate	0
Tx bytes	818064
Rx bytes	0

VPI/VCI		0/33	-	-	-	-	-	-
Tx packets	6355	-	-	-	-	-	-	-
Rx packets	0	-	-	-	-	-	-	-
Tx rate	304	-	-	-	-	-	-	-
Rx rate	0	-	-	-	-	-	-	-
Tx cells	17043	-	-	-	-	-	-	-
Rx cells	0	-	-	-	-	-	-	-
Errors	0	-	-	-	-	-	-	-

Poll Interval(s):

Port:

The following table describes the labels in this screen.

**Table 8** ADSL Port Statistics

LABEL	DESCRIPTION
Return	Click this link to go back to the <b>Home</b> screen.
xDSL Port	Use this drop-down list box to select a port for which you wish to view statistics. This field identifies the port described in this screen.
Port Name	This field displays the name that you have configured for the port.
Tx packets	This field shows the number of packets transmitted on this port.
Rx packets	This field shows the number of packets received on this port.
Tx broadcast packets	This field shows the number of packets transmitted on this port.
Rx broadcast packets	This field shows the number of broadcast packets received on this port.
Tx discard packets	This field shows the number of outgoing packets that were dropped on this port.
Rx discard packets	This field shows the number of received packets that were dropped on this port.
Errors	This field shows the number of error packets on this port.
Tx rate	This field shows the number of kilobytes per second transmitted on this port.
Rx rate	This field shows the number of kilobytes per second received on this port.

**Table 8** ADSL Port Statistics (continued)

LABEL	DESCRIPTION
Tx bytes	This field shows the number of kilobytes that have been transmitted on this port.
Rx bytes	This field shows the number of kilobytes that have been received on this port.
VPI/VCI	This field displays the Virtual Path Identifier (VPI) and Virtual Circuit Identifier (VCI) of channels on this port.
Tx packets	This field shows the number of packets transmitted on each channel.
Rx packets	This field shows the number of packets received on each channel.
Tx rate	This field shows the number of kilobytes per second transmitted on each channel.
Rx rate	This field shows the number of kilobytes per second received on each channel.
Tx cells	This field shows the number of ATM cells transmitted on each channel.
Rx cells	This field shows the number of ATM cells received on each channel.
Errors	This field shows the number of error packets on each channel.
Poll Interval(s)	The text box displays how often (in seconds) this screen refreshes. You may change the refresh interval by typing a new number in the text box and then clicking <b>Set Interval</b> .
Stop	Click <b>Stop</b> to halt system statistic polling.
Clear Counter	Select a port from the <b>Port</b> drop-down list box and then click <b>Clear Counter</b> to erase the recorded statistical information for that port.



# CHAPTER 7

## Basic Setting Screens

This chapter describes how to configure the **System Information**, **General Setup**, **Switch Setup**, **IP Setup** and **ENET Port Setup** screens.

### 7.1 Basic Setting Screens Overview

The **System Information** screen displays general AAM information (such as firmware version number) and hardware polling information (such as fan status).

The **General Setup** screen allows you to configure general AAM identification information. It also allows you to set the system time manually or get the current time and date from an external server when you turn on your AAM. The real time is then displayed in the AAM logs.

The **Switch Setup** screen allows you to set up and configure global switch features.

The **IP Setup** screen allows you to configure a AAM IP address, subnet mask and DNS (domain name server) for management purposes.

The **ENET Port Setup** screen allows you to configure settings for the Ethernet ports.

See [Chapter 8 on page 83](#) for how to use the **xDSL Port Setup** screens to configure the ADSL ports.

### 7.2 System Information

In the navigation panel, click **Basic Setting** and then **System Information** to display the screen as shown. You can check the firmware version number and monitor the hardware status in this screen.

**Figure 36** System Information

System Info

System Name	ZyNOS
ZyNOS F/W Version	V3.50(ABA.0)b6   05/18/2005
DSP F/W Version	6.02.0005
Hardware Version	
Serial Number	
Ethernet Address	00:13:49:ad:ea:d7

Hardware Monitor  
 Enable  
 Temperature Unit C

Temperature- C	Current	MAX	MIN	Average	Threshold( Low)	Threshold( Hi)	Status
1	31	31	28	28	-55	97	Normal
2	37	37	29	34	-55	97	Normal
3	36	36	30	33	-55	97	Normal

Voltage	Current	MAX	MIN	Average	Threshold( Low)	Threshold( Hi)	Status
1	1.152	1.165	1.152	1.152	1.056	1.344	Normal
2	1.806	1.806	1.806	1.806	1.656	1.944	Normal
3	3.200	3.257	3.200	3.200	3.036	3.564	Normal
4	18.175	19.028	18.175	18.175	16.560	19.440	Normal

New threshold Apply

Temperature- C ( Hi)	Temperature- C ( Lo)	Volt. ( Hi)	Volt. ( Lo)
<input style="width: 50px;" type="text" value="97"/>	<input style="width: 50px;" type="text" value="-55"/>	<input style="width: 50px;" type="text" value="1.344"/>	<input style="width: 50px;" type="text" value="1.056"/>
<input style="width: 50px;" type="text" value="97"/>	<input style="width: 50px;" type="text" value="-55"/>	<input style="width: 50px;" type="text" value="1.944"/>	<input style="width: 50px;" type="text" value="1.656"/>
<input style="width: 50px;" type="text" value="97"/>	<input style="width: 50px;" type="text" value="-55"/>	<input style="width: 50px;" type="text" value="3.564"/>	<input style="width: 50px;" type="text" value="3.036"/>
		<input style="width: 50px;" type="text" value="19.440"/>	<input style="width: 50px;" type="text" value="16.560"/>

Poll Interval( s) 40
Set Interval
Stop

The following table describes the labels in this screen.

**Table 9** System Information

LABEL	DESCRIPTION
System Name	This field displays the AAM's model name.
ZyNOS F/W Version	This field displays the version number of the AAM's current firmware including the date created.
DSP F/W Version	This field displays the Digital Signal Processor firmware version number. This is the modem code firmware.
Hardware Version	This field displays the hardware version number of your AAM.
Serial Number	This field displays the serial number of your AAM.
Ethernet Address	This field refers to the Ethernet MAC (Media Access Control) address of the AAM.
Hardware Monitor	
Enable	Select this check box to turn the hardware monitor on or clear it to turn the hardware monitor off.
Temperature Unit	Select <b>C</b> to display all temperature measurements in degrees Celsius. Select <b>F</b> to display all temperature measurements in degrees Fahrenheit.

**Table 9** System Information (continued)

<b>LABEL</b>	<b>DESCRIPTION</b>
Temperature	Each temperature sensor can detect and report the temperature. Temperature sensor 1 is near the ADSL line driver. Temperature sensor 2 is near the ADSL chipset. Temperature sensor 3 is near the central processing unit.
Current	This shows the current temperature at this sensor.
MAX	This field displays the maximum temperature measured at this sensor.
MIN	This field displays the minimum temperature measured at this sensor.
Average	This field displays the average temperature measured at this sensor.
Threshold (Low)	This field displays the lowest temperature limit at this sensor.
Threshold (Hi)	This field displays the highest temperature limit at this sensor.
Status	This field displays <b>Normal</b> for temperatures below the threshold and <b>Over</b> for those above.
Voltage	The power supply for each voltage has a sensor that can detect and report the voltage.
Current	This is the current voltage reading.
MAX	This field displays the maximum voltage measured at this point.
MIN	This field displays the minimum voltage measured at this point.
Average	This field displays the average voltage measured at this sensor.
Threshold (Low)	This field displays the lowest voltage limit at this sensor.
Threshold (Hi)	This field displays the highest voltage limit at this sensor.
Status	<b>Normal</b> indicates that the voltage is within an acceptable operating range at this point; otherwise <b>Abnormal</b> is displayed.
Use this section of the screen to configure the hardware monitor threshold settings.	
New threshold	Configure new threshold settings in the fields below and click <b>Apply</b> to use them.
Temperature (Hi)	Use these fields to configure the highest temperature limit at each sensor.
Temperature (Low)	Use these fields to configure the lowest temperature limit at each sensor.
Volt. (Hi)	Use these fields to configure the highest voltage limit at each sensor.
Volt. (Low)	Use these fields to configure the lowest voltage limit at each sensor.
Poll Interval(s)	The text box displays how often (in seconds) this screen refreshes. You may change the refresh interval by typing a new number in the text box and then clicking <b>Set Interval</b> .
Stop	Click <b>Stop</b> to halt statistic polling.

## 7.3 General Setup

Click **Basic Setting** and **General Setup** in the navigation panel to display the screen as shown.

**Figure 37** General Setup

**General Setup**

Host Name

Location

Contact Person's Name

Model AAM1212-51

Use Time Server when Bootup

Time Server IP Address

Current Time  :  :

New Time(hh: mm: ss)  :  :

Current Date  -  -

New Date(yyy- mm- dd)  -  -

Time Zone

**When synchronizing with time server, it will take 60 seconds if time server is unreachable.**

The following table describes the labels in this screen.

**Table 10** General Setup

LABEL	DESCRIPTION
Host Name	Choose a descriptive name for identification purposes. This name consists of up to 31 ASCII characters; spaces are allowed.
Location	Enter the geographic location of your AAM. You can use up to 31 ASCII characters; spaces are not allowed.
Contact Person's Name	Enter the name of the person in charge of this AAM. You can use up to 31 ASCII characters; spaces are not allowed.
Model	This field displays your device type.
Use Time Server When Bootup	<p>Enter the time service protocol that a timeserver uses. Not all timeservers support all protocols, so you may have to use trial and error to find a protocol that works. The main differences between them are the time format.</p> <p>When you select the <b>Daytime (RFC 867)</b> format, the switch displays the day, month, year and time with no time zone adjustment. When you use this format it is recommended that you use a Daytime timeserver within your geographical time zone.</p> <p><b>Time (RFC-868)</b> format displays a 4-byte integer giving the total number of seconds since 1970/1/1 at 0:0:0.</p> <p><b>NTP (RFC-1305)</b> is similar to Time (RFC-868).</p> <p><b>None</b> is the default value. Enter the time manually. Each time you turn on the AAM, the time and date will be reset to 2000-1-1 0:0.</p>
Time Server IP Address	Enter the IP address (or URL if you configure a domain name server in the IP Setup screen) of your timeserver. The AAM searches for the timeserver for up to 60 seconds. If you select a timeserver that is unreachable, then this screen will appear locked for 60 seconds. Please wait.
Current Time	This field displays the time you open this menu (or refresh the menu).

**Table 10** General Setup (continued)

LABEL	DESCRIPTION
New Time (hh:min:ss)	Enter the new time in hour, minute and second format. The new time then appears in the <b>Current Time</b> field after you click <b>Apply</b> .
Current Date	This field displays the date you open this menu.
New Date (yyyy-mm-dd)	Enter the new date in year, month and day format. The new date then appears in the <b>Current Date</b> field after you click <b>Apply</b> .
Time Zone	Select the time difference between UTC (Universal Time Coordinated, formerly known as GMT, Greenwich Mean Time) and your time zone from the drop-down list box.
Apply	Click <b>Apply</b> to save your changes to the AAM's volatile memory. The AAM loses these changes if it is turned off or loses power, so use the <b>Config Save</b> link on the navigation panel to save your changes to the non-volatile memory when you are done configuring.
Cancel	Click <b>Cancel</b> to start configuring the screen again.

## 7.4 IGMP Snooping

IGMP (Internet Group Multicast Protocol) is a session-layer protocol used to establish membership in a multicast group - it is not used to carry user data. Refer to RFC 1112 and RFC 2236 for information on IGMP versions 1 and 2 respectively.

A switch can passively snoop on IGMP Query, Report and Leave (IGMP version 2) packets transferred between IP multicast routers/switches and IP multicast hosts to learn the IP multicast group membership. It checks IGMP packets passing through it, picks out the group registration information, and configures multicasting accordingly. IGMP snooping allows the switch to learn multicast groups without you having to manually configure them.

The switch forwards multicast traffic destined for multicast groups (that it has learned from IGMP snooping or that you have manually configured) to ports that are members of that group. The switch discards multicast traffic destined for multicast groups that it does not know. IGMP snooping generates no additional network traffic, allowing you to significantly reduce multicast traffic passing through your switch.

## 7.5 Switch Modes

The AAM supports standalone and daisychain switch modes.

### 7.5.1 Standalone Switch Mode

"Standalone switch mode" relates to the AAM's operational behavior, not a standalone network topology. The standalone switch mode allows either or both of the AAM's Ethernet ports to connect to the backbone Ethernet network. You can also connect one of the AAM's Ethernet ports to the Ethernet network and the other to another AAM (see [Figure 38 on page](#)

76 for an example). When the AAM is in standalone mode, you can use it in a network topology that uses loops (you should also enable RSTP). You can have multiple AAMs connected on the same network and set both of them to use standalone mode in order to use them with a network topology that uses loops.

When in standalone switch mode, the AAM uses both Ethernet ports (**LAN 1** and **LAN 2**) as uplink ports and only forwards IGMP queries to the ADSL ports.

Standalone switch mode with port isolation enabled blocks communications between subscriber ports on an individual AAM. However, one AAM's subscribers can communicate with another AAM's subscribers if the two AAMs' Ethernet ports are connected to each other (see [Figure 38 on page 76](#) for an example). If you have multiple AAMs connected on the same network and set to standalone mode, they do not all need to have the same port isolation setting.

## 7.5.2 Port Isolation with Standalone Switch Mode Example

The following graphic shows AAMs **1** and **2** connected to each other and the Ethernet backbone switch (**3**) in a network topology that creates a loop. The AAMs are using the standalone switch mode and have RSTP enabled.

In this example, both AAMs have port isolation turned on. Communications between **A** and **B** must first go through another switch (**3** in the figure). However, **A** and **B** can communicate with **C** without their communications going through another switch or router.

**Figure 38** Port Isolation with Standalone Switch Mode Example

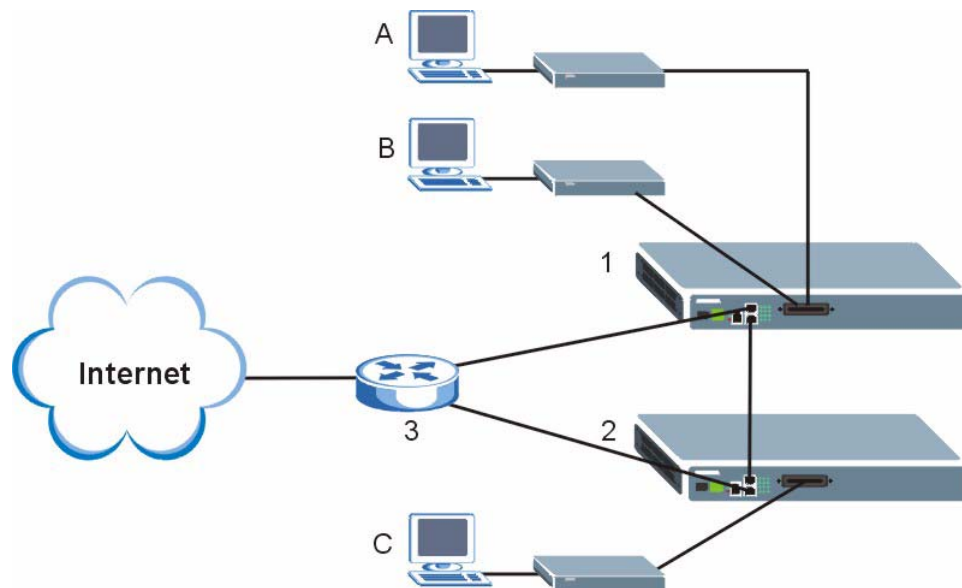

### 7.5.3 Daisychain Switch Mode

Daisychain switch mode sets the AAM to use Ethernet port one (**LAN 1**) as an uplink port to connect to the Ethernet backbone and Ethernet port two (**LAN 2**) to connect to another (daisychained or subtending) AAM. The daisychain switch mode is recommended for use in a network topology that does not have loops. When you daisychain multiple AAMs they must all be set to daisychain mode.

In daisychain switch mode, the AAM forwards IGMP queries from Ethernet port one (**LAN 1**) to Ethernet port 2 (**LAN 2**) and to the ADSL ports. Daisychain switch mode is recommended for using IGMP snooping with daisychained (cascaded) AAMs.

Daisychain switch mode with port isolation enabled blocks communications between subscriber ports on an individual AAM and between the subscribers of any daisychained AAMs (see [Figure 39 on page 77](#) for an example). Use the same port isolation setting on all AAMs that you set up in a daisychain.

### 7.5.4 Port Isolation with Daisychain Switch Mode Example

See the following graphic. AAM **1** has its Ethernet port one (**LAN 1**) connected to the Ethernet backbone switch (**3**) and its Ethernet port two (**LAN2**) connected to Ethernet port one (**LAN 1**) of the daisychained AAM **2**.

With port isolation turned on, communications between **A** and **B** must first go through another switch or router (**3** in the figure). **A** and **B** also cannot communicate with **C** without their communications going through another switch or router.

**Figure 39** Port Isolation with Daisychain Switch Mode Example

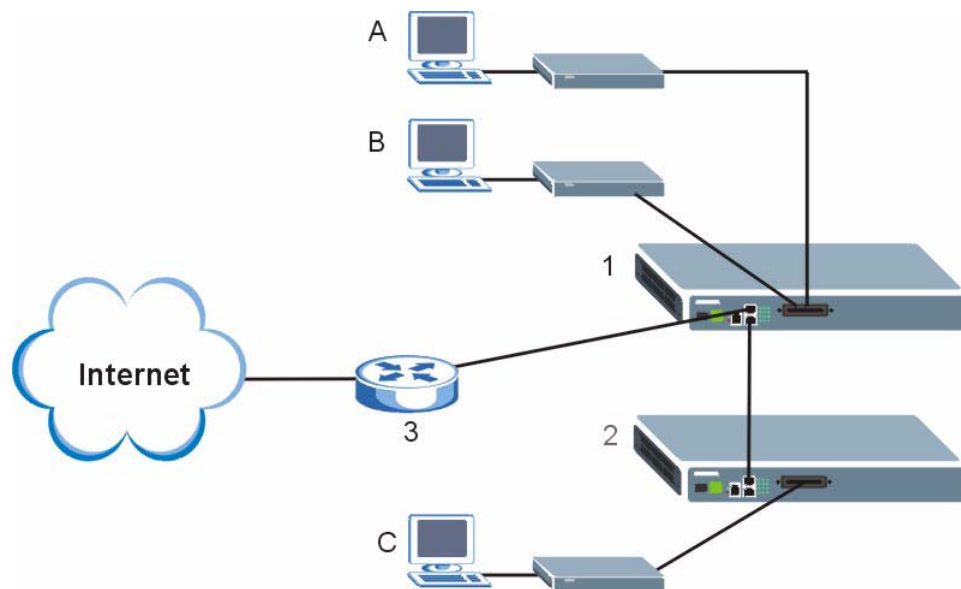

## 7.6 Switch Setup Screen

Click **Basic Setting** and then **Switch Setup** in the navigation panel to display the screen as shown.

**Figure 40** Switch Setup

The screenshot shows the 'Switch Setup' configuration screen. It includes the following settings:

- IGMP Snooping:** Active (checkbox)
- MAC Address Learning:** Aging Time: 300 (10-3000) seconds 0:Disabled
- GARP Timer:**
  - Join Timer: 200 (100-65535) milliseconds
  - Leave Timer: 600 (0-65535) milliseconds
  - Leave All Timer: 10000 (0-65535) milliseconds
- Port Isolation:** Active (checkbox)
- Switch Mode:** Standalone (dropdown)
- Priority Queue Assignment:**
  - Level 7: Queue 3 (dropdown)
  - Level 6: Queue 3 (dropdown)
  - Level 5: Queue 2 (dropdown)
  - Level 4: Queue 2 (dropdown)
  - Level 3: Queue 1 (dropdown)
  - Level 2: Queue 0 (dropdown)
  - Level 1: Queue 0 (dropdown)
  - Level 0: Queue 1 (dropdown)

Buttons for 'Apply' and 'Cancel' are located at the bottom of the screen.

The following table describes the labels in this screen.

**Table 11** Switch Setup

LABEL	DESCRIPTION
IGMP Snooping	Select <b>Active</b> to enable IGMP snooping have group multicast traffic only forwarded to ports that are members of the VLAN, significantly reducing multicast traffic passing through your AAM.
MAC Address Learning	MAC address learning reduces outgoing traffic broadcasts. For MAC address learning to occur on a port, the port must be active.
Aging Time	Enter a time from 10 to 765 seconds. This is how long all dynamically learned MAC addresses remain in the MAC address table before they age out (and must be relearned).
GARP Timer: Switches join VLANs by making a declaration. A declaration is made by issuing a Join message using GARP. Declarations are withdrawn by issuing a Leave message. A Leave All message terminates all registrations. GARP timers set declaration timeout values. See the chapter on VLAN setup for more background information.	
Join Timer	Join Timer sets the duration of the Join Period timer for GVRP in milliseconds. Each port has a Join Period timer. The allowed Join Time range is between 100 and 65535 milliseconds; the default is 200 milliseconds. See the chapter on VLAN setup for more background information.
Leave Timer	Leave Timer sets the duration of the Leave Period timer for GVRP in milliseconds. Each port has a single Leave Period timer. Leave Time must be two times larger than Join Timer; the default is 600 milliseconds.

**Table 11** Switch Setup (continued)

LABEL	DESCRIPTION
Leave All Timer	Leave All Timer sets the duration of the Leave All Period timer for GVRP in milliseconds. Each port has a single Leave All Period timer. Leave All Timer must be larger than Leave Timer.
Port Isolation	Turn on port isolation to block communications between subscriber ports. When you enable port isolation you do not need to configure the VLAN to isolate subscribers.
Switch Mode	<p>Select <b>Standalone</b> to use both of the AAM's Ethernet ports (<b>LAN 1</b> and <b>LAN 2</b>) as uplink ports.</p> <p><b>Note:</b> Standalone mode is recommended for network topologies that use loops.</p> <p>Use <b>Daisychain</b> mode to cascade (daisychain) multiple AAMs. The AAM uses Ethernet port one (<b>LAN 1</b>) as an uplink port to connect to the Ethernet backbone and uses Ethernet port two (<b>LAN 2</b>) to connect to another (daisychained or subtending) AAM.</p> <p><b>Note:</b> Daisychain mode is recommended for network topologies that do not use loops.</p>
<p>Priority Queue Assignment</p> <p>IEEE 802.1p defines up to 8 separate traffic types by inserting a tag into a MAC-layer frame that contains bits to define class of service. Frames without an explicit priority tag are given the default priority of the ingress port. Use the next two fields to configure the priority level-to-physical queue mapping.</p> <p>The switch has 4 physical queues that you can map to the 8 priority levels. On the switch, traffic assigned to higher index queues gets through faster while traffic in lower index queues is dropped if the network is congested.</p> <p>See also <b>Queuing Method</b> and <b>Priority</b> in <b>Port Setup</b> for related information.</p>	
Priority Level (The following descriptions are based on the traffic types defined in the IEEE 802.1d standard (which incorporates IEEE 802.1p).	
Level 7	Typically used for network control traffic such as router configuration messages.
Level 6	Typically used for voice traffic that is especially sensitive to jitter (jitter is the variations in delay).
Level 5	Typically used for video that consumes high bandwidth and is sensitive to jitter.
Level 4	Typically used for controlled load, latency-sensitive traffic such as SNA (Systems Network Architecture) transactions.
Level 3	Typically used for "excellent effort" or better than best effort and would include important business traffic that can tolerate some delay.
Level 2	This is for "spare bandwidth".
Level 1	This is typically used for non-critical "background" traffic such as bulk transfers that are allowed but that should not affect other applications and users.
Level 0	Typically used for best-effort traffic.
Apply	Click <b>Apply</b> to save your changes to the AAM's volatile memory. The AAM loses these changes if it is turned off or loses power, so use the <b>Config Save</b> link on the navigation panel to save your changes to the non-volatile memory when you are done configuring.
Cancel	Click <b>Cancel</b> to begin configuring this screen afresh.

## 7.7 IP Setup

Click **Basic Setting** and then **IP Setup** in the navigation panel to display the screen as shown. Use this screen to configure the system and management IP addresses and subnet masks.

**Figure 41** IP Setup

The following table describes the labels in this screen.

**Table 12** IP Setup

LABEL	DESCRIPTION
IP	Enter the IP address of your AAM in dotted decimal notation for example 1.2.3.4.
IP Mask	Enter the IP subnet mask of your AAM in dotted decimal notation for example 255.255.255.0.
Apply IP setting	Click <b>Apply IP setting</b> to save your changes to the device's IP address and/or subnet mask to the AAM's volatile memory. The AAM loses these changes if it is turned off or loses power, so use the <b>Config Save</b> link on the navigation panel to save your changes to the non-volatile memory when you are done configuring.
Cancel	Click <b>Cancel</b> to begin configuring the fields again.
Default Gateway	Enter the IP address of the default outgoing gateway in dotted decimal notation.
Apply Gateway setting	Click <b>Apply Gateway setting</b> to save your changes to the device's IP address and/or subnet mask to the AAM's volatile memory. The AAM loses these changes if it is turned off or loses power, so use the <b>Config Save</b> link on the navigation panel to save your changes to the non-volatile memory when you are done configuring.
Cancel	Click <b>Cancel</b> to begin configuring the fields again.

## 7.8 ENET Port Setup

Click **Basic Setting** and then **ENET Port Setup** in the navigation panel to enter the Ethernet port configuration screen.

**Figure 42** ENET Port Setup

Port	Active	Name	Speed Mode	Duplex
ENET1	<input checked="" type="checkbox"/>	enet1	Auto	Full Duplex
ENET2	<input checked="" type="checkbox"/>	enet2	Auto	Full Duplex

The following table describes the fields in this screen.

**Table 13** ENET Port Setup

LABEL	DESCRIPTION
Port	This is the port index number.
Active	Select this check box to enable a port. The factory default for all ports is enabled. A port must be enabled for data transmission to occur.
Name	Enter a descriptive name that identifies this port. You can use up to 31 ASCII characters; spaces are not allowed.
Speed Mode	<p>Select the type of Ethernet connection for this port. When you don't use auto-negotiation, you must make sure that the settings of the peer Ethernet port are the same in order to connect.</p> <p>Select <b>Auto</b> (auto-negotiation) to have the AAM automatically determine the type of connection that the Ethernet port has. When the peer Ethernet device has auto-negotiation turned on, the AAM negotiates with the peer to determine the connection speed. If the peer Ethernet port does not have auto-negotiation turned on, the AAM determines the connection speed by detecting the signal on the cable and using full duplex.</p> <p>Select <b>10 Copper</b> if the Ethernet port has a 10 MB electrical connection.</p> <p>Select <b>100 Copper</b> if the Ethernet port has a 100 MB electrical connection.</p>
Duplex	The AAM uses full duplex Ethernet connections.
Apply	Click <b>Apply</b> to save your changes to the AAM's volatile memory. The AAM loses these changes if it is turned off or loses power, so use the <b>Config Save</b> link on the navigation panel to save your changes to the non-volatile memory when you are done configuring.
Cancel	Click <b>Cancel</b> to begin configuring the fields again.



# CHAPTER 8

## ADSL Port Setup

This chapter explains how to configure settings for profiles and individual ADSL ports. It also covers how to configure virtual channels and virtual channel profiles.

### 8.1 ADSL Standards Overview

These are the ADSL standards and rates that the AAM supports at the time of writing.

**Table 14** Maximum Transfer Rates of the ADSL Ports

STANDARD	MAXIMUM DOWNSTREAM	MAXIMUM UPSTREAM
G.dmt (AAM1212-51)	8160 Kbps	1024 Kbps
G.dmt Annex B (AAM1212-53)	8160 Kbps	1024 Kbps
ETSI (AAM1212-53)	8160 Kbps	1024 Kbps
ANSI T1.413 issue 2 (AAM1212-51)	8160 Kbps	1024 Kbps
G.lite (AAM1212-51)	1536 Kbps	512 Kbps
ADSL2	12000 Kbps	1200 Kbps
ADSL2+	24000 Kbps	1200 Kbps

### 8.2 Downstream and Upstream

Downstream refers to traffic going out from the AAM to the subscriber's ADSL modem or router. Upstream refers to traffic coming into the AAM from the subscriber's ADSL modem or router.

### 8.3 Profiles

A profile is a table that contains a list of pre-configured ADSL settings. Each ADSL port has one (and only one) profile assigned to it at any given time. The profile defines the latency mode and upstream/downstream latency delay, maximum and minimum upstream/downstream rates, the target upstream/downstream signal noise margins, and the maximum and minimum upstream/downstream acceptable noise margins of all the ADSL ports that have this profile. You can configure multiple profiles, including profiles for troubleshooting.

Profiles allow you to configure ADSL ports efficiently. You can configure all of the ADSL ports with the same profile, thus removing the need to configure the ADSL ports one-by-one. You can also change an individual ADSL port by assigning it a different profile.

For example, you could set up different profiles for different kinds of accounts (for example, economy, standard and premium). Assign the appropriate profile to an ADSL port and it takes care of a large part of the port's configuration maximum and minimum transfer rates. You still get to individually enable or disable each port, as well as configure its channels and operational mode. See later in this chapter for how to configure profiles.

## 8.4 Interleave Delay

Interleave delay is the wait (in milliseconds) that determines the size of a single block of data to be interleaved (assembled) and then transmitted. Interleave delay is used when transmission error correction (Reed- Solomon) is necessary due to a less than ideal telephone line. The bigger the delay, the bigger the data block size, allowing better error correction to be performed.

Reed-Solomon codes are block-based error correcting codes with a wide range of applications. The Reed-Solomon encoder takes a block of digital data and adds extra "redundant" bits. The Reed-Solomon decoder processes each block and attempts to correct errors and recover the original data.

### 8.4.1 Fast Mode

Fast mode means no interleaving takes place and transmission is faster (a "fast channel"). This would be suitable if you have a good line where little error correction is necessary.

## 8.5 Configured Versus Actual Rate

You configure the maximum rate of an individual ADSL port by modifying its profile or assigning a different profile to the port. However, due to noise and other factors on the line, the actual rate may not reach the maximum that you specify.

Even though you can specify arbitrary numbers for a profile, the actual rate is always a multiple of 32 Kbps. If you enter a rate that is not a multiple of 32 Kbps, the actual rate will be the next lower multiple of 32Kbps. For instance, if you specify 60 Kbps for a port, the actual rate for that port will not exceed 32 Kbps, and if you specify 66 Kbps, the actual rate will not be over 64Kbps.

Regardless of a profile's configured upstream and downstream rates, the AAM automatically limits the actual rates for each individual port to the maximum speeds supported by the port's ADSL operational mode. For example, if you configure a profile with a maximum downstream rate of 25000 Kbps, and apply it to a port set to use G.dmt, the AAM automatically uses a maximum downstream rate of 8160 Kbps. This means that if you configure a profile with very high rates, you can still use it with any port. See [Table 14 on page 83](#) for a list of the maximum rates supported by the different ADSL standards.

## 8.6 Default Settings

The default profile always exists and all of the ADSL ports use the default profile settings when the AAM is shipped. The default profile's name is set to DEFVAL. The default profile's maximum downstream rate can only be obtained when using the G.dmt standard. Configure a profile with a maximum downstream rate of 1536 Kbps or less for use with G.lite.

Refer to the chapter on initial configuration for the settings of the default profile and ADSL port default settings.

## 8.7 xDSL Port Setup

Click **Basic Setting** and then **xDSL Port Setup** in the navigation panel to open the following screen.

**Figure 43** xDSL Port Setup

Port	Active	Customer Info	Customer Tel	Profile	Mode	Channels
<a href="#">1</a>	enabled			DEFVAL	auto	1
<a href="#">2</a>	enabled			DEFVAL	auto	1
<a href="#">3</a>	enabled			DEFVAL	auto	1
<a href="#">4</a>	enabled			DEFVAL	auto	1
<a href="#">5</a>	enabled			DEFVAL	auto	1
<a href="#">6</a>	enabled			DEFVAL	auto	1
<a href="#">7</a>	enabled			DEFVAL	auto	1
<a href="#">8</a>	enabled			DEFVAL	auto	1
<a href="#">9</a>	enabled			DEFVAL	auto	1
<a href="#">10</a>	enabled			DEFVAL	auto	1
<a href="#">11</a>	enabled			DEFVAL	auto	1
<a href="#">12</a>	enabled			DEFVAL	auto	1

The following table describes the fields in this screen.

**Table 15** xDSL Port Setup

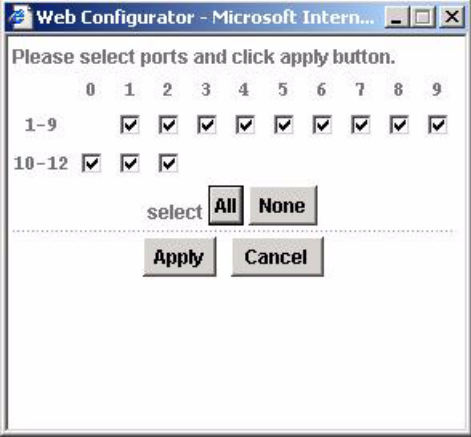
LABEL	DESCRIPTION
VC Setup	Click <b>VC Setup</b> to open the <b>VC Setup</b> screen where you can configure VC settings for the DSL ports.
Copy Port	<p>Do the following to copy settings from one DSL port to another DSL port or ports.</p> <ol style="list-style-type: none"> <li>1. Select the number of the DSL port from which you want to copy settings.</li> <li>2. Select the settings that you want to copy.</li> <li>3. Click <b>Paste</b> and the following screen appears.</li> <li>4. Select to which ports you want to copy the settings. Use <b>All</b> to select every port. Use <b>None</b> to clear all of the check boxes.</li> <li>5. Click <b>Apply</b> to paste the settings.</li> </ol> 
Active	Select this check box to copy this port's active setting. This is configured in the <b>xDSL Port Setting</b> screen.
Customer Info	Select this check box to copy this port's subscriber information. This is configured in the <b>xDSL Port Setting</b> screen.
Customer Tel	Select this check box to copy this port's subscriber's telephone number. This is configured in the <b>xDSL Port Setting</b> screen.
2+ Features	Select this check box to copy this port's ADSL2+ feature settings. These are configured in the <b>xDSL Port Setting</b> screen.
Profile&Mode	Select this check box to copy this port's port profile settings and ADSL operational mode. The port profile settings are configured in the <b>xDSL Profiles Setup</b> screen. The ADSL operational mode is configured in the <b>xDSL Port Setting</b> screen.
IGMP Filter	Select this check box to copy this port's IGMP filter settings. These are configured in the <b>IGMP Filter Profile</b> screen.
Security	Select this check box to copy this port's security settings. This is configured in the <b>Port Security</b> screen (see the chapter on port security).
Frame Type	Select this check box to copy this port's allowed frame type. This is configured in the <b>Static VLAN Setting</b> screen (see the chapter on VLAN).
Virtual Channels	Select this check box to copy this port's virtual channel settings. These are configured in the <b>VC Setup</b> screen.
Alarm Profile	Select this check box to copy this port's alarm profile. This is configured in the <b>Alarm Profile Setup</b> screen.
PVID & Priority	Select this check box to copy this port's PVID and priority settings. These are configured in the <b>VLAN Port Setting</b> screen (see the chapter on VLAN).

**Table 15** xDSL Port Setup (continued)

LABEL	DESCRIPTION
Packet Filter	Select this check box to copy this port's packet filter settings. These are configured in the <b>Packet Filtering</b> screen (see the chapter on packet filtering).
Port	This field shows the port index number.
Active	This field shows whether the port is enabled or not.
Customer Info	This field shows information you configured in the <b>xDSL Port Setting</b> screen to identify the subscriber.
Customer Tel	This field shows the subscriber's telephone number you configured in the <b>xDSL Port Setting</b> screen.
Profile	This field shows which profile is assigned to this port.
Mode	This field shows which ADSL operational mode the port is set to use.
Channels	This field displays the number of PVCs (Permanent Virtual Circuits) that are configured for this port.

## 8.7.1 xDSL Port Setting

Click **Basic Setting, xDSL Port Setup** in the navigation panel and then a port's index number to open the following screen.

**Figure 44** xDSL Port Setting

**xDSL Port Setting** [Last Page](#)

**Port 1**

**General Setup**

Active

Customer Info

Customer Tel

Profile DEFVAL ▼

Mode auto ▼

Alarm Profile DEFVAL ▼

IGMP Filter Profile DEFVAL ▼

**ADSL2/2+ feature**

Annex L disable ▼

PMM disable ▼

SRA enable ▼

**Apply** **Cancel**

The following table describes the fields in this screen.

**Table 16** xDSL Port Setting

LABEL	DESCRIPTION
Last Page	Click this to return to the previous screen.
Active	Select this check box to turn on this ADSL port.
Customer Info	Enter information to identify the subscriber connected to this ADSL port. You can use up to 31 printable ASCII characters (including spaces and hyphens).
Customer Tel	Enter information to identify the telephone number of the subscriber connected to this ADSL port. You can use up to 15 ASCII characters (including spaces and hyphens).
Profile	Select a profile of ADSL settings (such as the transfer rate, interleave delay and signal to noise ratio settings) to assign to this port. Use the <b>Port Profile</b> screen to configure port profiles.
Mode	Select the port's ADSL operational mode. Select the mode that the subscriber's device uses or <b>auto</b> to have the AAM automatically determine the mode to use. See <a href="#">Table 14 on page 83</a> for information on the individual ADSL modes.
Alarm Profile	The alarm profile defines thresholds that trigger an alarm when exceeded.
IGMP Filter Profile	The IGMP filter profile defines which multicast groups a port can join. Select a profile of IGMP filter settings to assign to this port. Use the <b>IGMP Filter Profile</b> screen to configure IGMP filter profiles (see <a href="#">Table 51 on page 103</a> ).
ADSL2/2+ feature	These are features available with ADSL2/2+. The subscriber's ADSL device must also support the individual features in order to use them. At the time of writing these features have not been fully tested and their performance and interoperability cannot be guaranteed.
Annex L	This field is not available on the AAM1212-53. Enable the Annex L feature to use reach extended ADSL2. This allows increased ADSL2 connection distances.
PMM	Enable the Power Management (PMM) feature to reduce the amount of power used overall and reduces the instances of the connection going down. PMM increases or decreases the transmission power based on line conditions. PMM also decreases the number of service interruptions.
SRA	Enable Seamless Rate Adaptation (SRA) to have the AAM automatically adjust the connection's data rate according to line conditions without interrupting service.
Apply	Click <b>Apply</b> to save your changes to the AAM's volatile memory. The AAM loses these changes if it is turned off or loses power, so use the <b>Config Save</b> link on the navigation panel to save your changes to the non-volatile memory when you are done configuring.
Cancel	Click <b>Cancel</b> to begin configuring the fields again.

## 8.8 Virtual Channels

Defining virtual channels (also called Permanent Virtual Circuits or PVCs) allows you to set priorities for different services or subscribers. You can define up to eight channels on each DSL port and use them for different services or levels of service. You set the PVID that is assigned to untagged frames received on each channel. You also set an IEEE 802.1p priority for each of the PVIDs. In this way you can assign different priorities to different channels (and consequently the services that get carried on them or the subscribers that use them).

For example, you want to give high priority to voice service on one of the ADSL ports.

First configure a static VLAN on the AAM for voice on the port.

Then do the following:

- Configure a channel on the port for voice service.
- Set the channel to use the PVID of the static VLAN you configured.
- Assign the channel a high priority.

### 8.8.1 Super Channel

The AAM forwards frames belonging to VLAN groups that are not assigned to specific channels to the super channel. Enable the super channel option to allow a channel forward frames belonging to multiple VLAN groups (that are not assigned to other channels). The super channel functions in the same way as the channel in a single channel environment. One port can have only one super channel.

### 8.8.2 LLC

LLC is a type of encapsulation where one VC (Virtual Circuit) carries multiple protocols with each packet header containing protocol identifying information. Despite the extra bandwidth and processing overhead, this method may be advantageous if it is not practical to have a separate VC for each carried protocol, for example, if charging heavily depends on the number of simultaneous VCs.

### 8.8.3 VC Mux

VC Mux is a type of encapsulation where, by prior mutual agreement, each protocol is assigned to a specific virtual circuit, for example, VC1 carries IP, VC2 carries IPX, and so on. VC-based multiplexing may be dominant in environments where dynamic creation of large numbers of ATM VCs is fast and economical.

### 8.8.4 Virtual Channel Profile

Virtual channel profiles allow you to configure the virtual channels efficiently. You can configure all of the virtual channels with the same profile, thus removing the need to configure the virtual channels one-by-one. You can also change an individual virtual channel by assigning it a different profile.

The AAM provides two default virtual channel profiles: **DEFVAL** (for LLC encapsulation) and **DEFVAL\_VC** (for VC encapsulation). By default, all virtual channels are associated to **DEFVAL**.

## 8.9 VC Setup Screen

Click **Basic Setting** and then **xDSL Port Setup** in the navigation panel and then the **VC Setup** link to open the following screen.

Use this screen to view and configure a port's channel (PVC) settings.

**Figure 45** VC Setup

VC Setup xDSL Port Setup

Port:  Super Channel:

VPI:  VCI:

VC Profile:

PVID:  (1-4094) Priority:

Show Port:

Index( Click to modify)	Port	VPI/VCI	VC Profile	PVID	Priority	Select
<a href="#">1</a>	1	0/ 33	DEFVAL	0	0	<input checked="" type="radio"/>
<a href="#">2</a>	2	0/ 33	DEFVAL	0	0	<input type="radio"/>
<a href="#">3</a>	3	0/ 33	DEFVAL	0	0	<input type="radio"/>
<a href="#">4</a>	4	0/ 33	DEFVAL	0	0	<input type="radio"/>
<a href="#">5</a>	5	0/ 33	DEFVAL	0	0	<input type="radio"/>
<a href="#">6</a>	6	0/ 33	DEFVAL	0	0	<input type="radio"/>
<a href="#">7</a>	7	0/ 33	DEFVAL	0	0	<input type="radio"/>
<a href="#">8</a>	8	0/ 33	DEFVAL	0	0	<input type="radio"/>
<a href="#">9</a>	9	0/ 33	DEFVAL	0	0	<input type="radio"/>
<a href="#">10</a>	10	0/ 33	DEFVAL	0	0	<input type="radio"/>
<a href="#">11</a>	11	0/ 33	DEFVAL	0	0	<input type="radio"/>
<a href="#">12</a>	12	0/ 33	DEFVAL	0	0	<input type="radio"/>

Index 1 selected  No Channel copied

The following table describes the fields in this screen.

**Table 17** VC Setup

LABEL	DESCRIPTION
xDSL Port Setup	Click <b>xDSL Port Setup</b> to go to the screen where you can configure DSL port settings.
Port	Use this drop-down list box to select a port for which you wish to view or configure settings.
Super Channel	The AAM forwards frames belonging to VLAN groups that are not assigned to specific channels to the super channel. Enable the super channel option to have this channel forward frames belonging to multiple VLAN groups (that are not assigned to other channels). The super channel functions in the same way as the channel in a single channel environment.
VPI	Type the Virtual Path Identifier for a channel on this port.
VCI	Type the Virtual Circuit Identifier for a channel on this port.

**Table 17** VC Setup

LABEL	DESCRIPTION
VC Profile	Use the drop-down list box to select a VC profile to assign to this channel.
PVID	Type a PVID (Port VLAN ID) to assign to untagged frames received on this channel. You cannot configure a PVID for a super channel. This must be the VLAN ID of a VLAN that is already configured. The port that you are configuring must also be set to the fixed status in the VLAN.
Priority	Type the priority value (0 to 7) to add to incoming frames without a (IEEE 802.1p) priority tag. An asterisk (*) denotes a super channel.
Add, Apply	Click <b>Add</b> to add channel settings on a port. Click <b>Apply</b> to save channel setting changes for a port. Click <b>Add</b> or <b>Apply</b> to save your changes to the AAM's volatile memory. The AAM loses these changes if it is turned off or loses power, so use the <b>Config Save</b> link on the navigation panel to save your changes to the non-volatile memory when you are done configuring.
Cancel	Click <b>Cancel</b> to start configuring the screen again.
Show Port	Select the number of an ADSL port for which to display VC settings (or display all of them).
Index	This field displays the number of the PVC. Click a PVC's index number to use the top of the screen to edit the PVC.  <b>Note:</b> At the time of writing, you can only edit the VC profile. If you want to change other settings, add a new PVC with the desired settings. Then you can delete any unwanted PVCs.
Port	This field displays the number of the ADSL port on which the PVC is configured.
VPI/VC	This field displays the Virtual Path Identifier (VPI) and Virtual Circuit Identifier (VCI). The VPI and VCI identify a channel on this port. Click a link in the <b>VPI/VCI</b> column to open a screen where you can edit the VPI/VCI settings.
VC Profile	This shows which VC profile the channel is set to use.
PVID	This is the PVID (Port VLAN ID) assigned to untagged frames or priority frames (0 VID) received on this channel. An asterisk (*) denotes a super channel.
Priority	This is the priority value (0 to 7) added to incoming frames without a (IEEE 802.1p) priority tag. An asterisk (*) denotes a super channel.

**Table 17** VC Setup

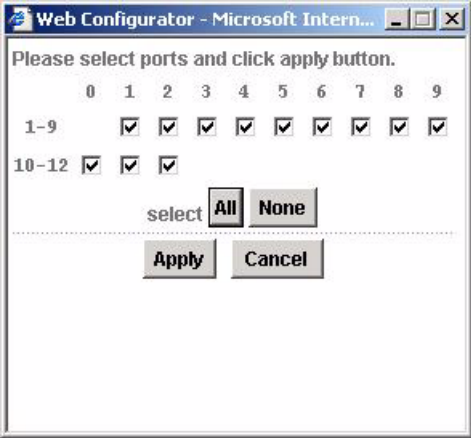
LABEL	DESCRIPTION
Delete	<p>Do the following to remove one or more PVCs.</p> <ol style="list-style-type: none"> <li>1. Select a PVC's <b>Select</b> radio button.</li> <li>2. Click <b>Delete</b>.</li> <li>3. Click <b>OK</b> if you want to remove the PVC from other ports. Click <b>Cancel</b> to only remove the one you selected.</li> </ol>  <ol style="list-style-type: none"> <li>4. If you clicked <b>OK</b>, the following screen appears.</li> <li>5. Select to which ports you want to copy the settings. Use <b>All</b> to select every port. Use <b>None</b> to clear all of the check boxes.</li> <li>6. Click <b>Apply</b> to delete the channels.</li> </ol> 

**Table 17** VC Setup

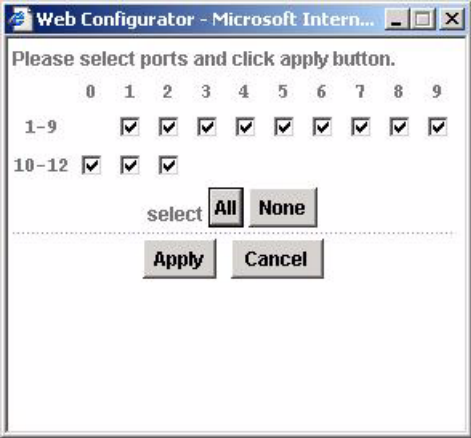
LABEL	DESCRIPTION
Copy, Paste	<p>Do the following to copy settings from one PVC to another port or ports.</p> <ol style="list-style-type: none"> <li>1. Click the <b>Select</b> radio button of the PVC from which you want to copy settings.</li> <li>2. Click <b>Paste</b>.</li> <li>3. The following screen appears.</li> <li>4. Select to which ports you want to copy the settings. Use <b>All</b> to select every port. Use <b>None</b> to clear all of the check boxes.</li> <li>5. Click <b>Apply</b> to copy the settings.</li> </ol> 

## 8.10 Port Profile Screen

A profile is a list of settings that you define. Then you can assign them to one or more individual ports.

Click **Basic Setting** and then **xDSL Profiles Setup** in the navigation panel to open the following screen.

**Figure 46** Port Profile

The following table describes the fields in this screen.

**Table 18** Port Profile

LABEL	DESCRIPTION
VC Profile	Click <b>VC Profile</b> to open the <b>VC Profile</b> screen where you can configure virtual channel profiles.
Alarm Profile	Click <b>Alarm Profile</b> to open the <b>Alarm Profile</b> screen where you can configure limits that trigger an alarm when exceeded.
IGMP Filter Profile	Click <b>IGMP Filter Profile</b> to open the <b>IGMP Filter Profile</b> screen where you can configure IGMP multicast filter profiles.
Index	This is the port profile index number.
Name	These are the names of individual profiles. The DEFVAL profile always exists and all of the DSL ports have it assigned to them by default. You can use up to 31 ASCII characters; spaces are not allowed.
Latency Mode	This is the ADSL latency mode (Fast or Interleave) for the ports that belong to this profile.
Down/Up Stream Rate (kbps)	These are the maximum downstream and upstream transfer rates for the ports that belong to this profile.
Modify	Select a profile's <b>Select</b> radio button and click <b>Modify</b> to edit the profile.
Delete	Select a profile's <b>Select</b> radio button and click <b>Delete</b> to remove the profile.
The rest of the screen is for profile configuration.	
Name	When editing a profile, this is the name of this profile. When adding a profile, type a name (up to 31 characters) for the profile.

**Table 18** Port Profile (continued)

LABEL	DESCRIPTION
Latency Mode	<p>This field sets the ADSL latency mode for the ports that belong to this profile.</p> <p>Select <b>Fast</b> mode to use no interleaving and have faster transmission (a “fast channel”). This would be suitable if you have a good line where little error correction is necessary.</p> <p>Select <b>Interleave</b> mode to use interleave delay when transmission error correction (Reed- Solomon) is necessary due to a less than ideal telephone line.</p> <p>See <a href="#">Section 8.4 on page 84</a> for more on interleave delay.</p>
Up Stream	The following parameters relate to upstream transmissions.
Max Rate (kbps)	Type a maximum upstream transfer rate (32 to 3000 Kbps) for this profile. Configure the maximum upstream transfer rate to be less than the maximum downstream transfer rate.
Min Rate (kbps)	Type the minimum upstream transfer rate (32 to 3000 Kbps) for this port. Configure the minimum upstream transfer rate to be less than the maximum upstream transfer rate.
Interleave Delay (ms)	Configure this field when you set the <b>Latency Mode</b> field to <b>Interleave</b> . Type the number of milliseconds (1-255) of interleave delay to use for upstream transfers. It is recommended that you configure the same latency delay for both upstream and downstream.
Max SNR (db)	Type the maximum upstream signal to noise margin (0-31 dB).
Min SNR (db)	Type the minimum upstream signal to noise margin (0-31 dB). Configure the minimum upstream signal to noise margin to be less than or equal to the maximum upstream signal to noise margin.
Target SNR (db)	Type the target upstream signal to noise margin (0-31 dB). Configure the target upstream signal to noise margin to be greater than or equal to the minimum upstream signal to noise margin and less than or equal to the maximum upstream signal to noise margin.
Down Stream	The following parameters relate to downstream transmissions.
Max Rate (kbps)	Type a maximum downstream transfer rate (32 to 25000 Kbps) bps for this port. Configure the maximum downstream transfer rate to be greater than the maximum upstream transfer rate.
Min Rate (Kbps)	Type the minimum downstream transfer rate (32 to 25000 Kbps) for this port. Configure the minimum downstream transfer rate to be less than the maximum downstream transfer rate.
Interleave Delay (ms)	Configure this field when you set the Latency Mode field to interleave. Type the number of milliseconds (1-255) of interleave delay to use for upstream transfers. It is recommended that you configure the same latency delay for both upstream and downstream.
Max SNR (db)	Type the maximum downstream signal to noise margin (0-31 dB).
Min SNR (db)	Type the minimum downstream signal to noise margin (0-31 dB). Configure the minimum downstream signal to noise margin to be less than or equal to the maximum downstream signal to noise margin.
Target SNR (db)	Type the target downstream signal to noise margin (0-31 dB). Configure the target downstream signal to noise margin to be greater than or equal to the minimum downstream signal to noise margin and less than or equal to the maximum downstream signal to noise margin.
Add	Click <b>Add</b> to save your changes to the AAM's volatile memory. The AAM loses these changes if it is turned off or loses power, so use the <b>Config Save</b> link on the navigation panel to save your changes to the non-volatile memory when you are done configuring.
Cancel	Click <b>Cancel</b> to start configuring the screen again.

## 8.11 ATM QoS

ATM Quality of Service (QoS) mechanisms provide the best service on a per-flow guarantee. ATM network infrastructure was designed to provide QoS. It uses fixed cell sizes and built-in traffic management (see the following section on traffic shaping). This allows you to fine-tune the levels of services on the priority of the traffic flow.

## 8.12 Traffic Shaping

Traffic shaping is an agreement between the carrier and the subscriber to regulate the average rate and fluctuations of data transmission over an ATM network. This agreement helps eliminate congestion, which is important for transmission of real time data such as audio and video connections.

### 8.12.1 ATM Traffic Classes

These are the basic ATM traffic classes defined by the ATM Forum Traffic Management 4.0 Specification.

#### 8.12.1.1 Constant Bit Rate (CBR)

Constant Bit Rate (CBR) is an ATM traffic class that provides fixed bandwidth. CBR traffic is generally time-sensitive (doesn't tolerate delay). CBR is used for connections that continuously require a specific amount of bandwidth. Examples of connections that need CBR would be high-resolution video and voice.

#### 8.12.1.2 Variable Bit Rate (VBR)

The Variable Bit Rate (VBR) ATM traffic class is used with bursty connections. Connections that use the Variable Bit Rate (VBR) traffic class can be grouped into real time (rt-VBR) or non-real time (nrt-VBR) connections.

The rt-VBR (real-time Variable Bit Rate) type is used with bursty connections that require closely controlled delay and delay variation. An example of an rt-VBR connection would be video conferencing. Video conferencing requires real-time data transfers and the bandwidth requirement varies in proportion to the video image's changing dynamics.

The nrt-VBR (non real-time Variable Bit Rate) type is used with bursty connections that do not require closely controlled delay and delay variation. An example of an nrt-VBR connection would be non-time sensitive data file transfers.

### 8.12.1.3 Unspecified Bit Rate (UBR)

The Unspecified Bit Rate (UBR) ATM traffic class is similar to the ABR traffic class for bursty data transfers. However, while ABR gives subscribers a set amount of bandwidth, UBR doesn't guarantee any bandwidth and only delivers traffic when the network has spare bandwidth.

## 8.12.2 Traffic Parameters

These are the parameters that control the flow of ATM traffic.

### 8.12.2.1 Peak Cell Rate (PCR)

Peak Cell Rate (PCR) is the maximum rate at which the sender can send cells. This parameter may be lower (but not higher) than the maximum line speed. 1 ATM cell is 53 bytes (424 bits), so a maximum speed of 832Kbps gives a maximum PCR of 1962 cells/sec. This rate is not guaranteed because it is dependent on the line speed.

### 8.12.2.2 Sustained Cell Rate (SCR)

Sustained Cell Rate (SCR) is the mean cell rate of each bursty traffic source. It specifies the maximum average rate at which cells can be sent over the virtual connection. SCR may not be greater than the PCR.

### 8.12.2.3 Maximum Burst Size (MBS)

Maximum Burst Size (MBS) is the maximum number of cells that can be sent at the PCR. After MBS is reached, cell rates fall below SCR until cell rate averages to the SCR again. At this time, more cells (up to the MBS) can be sent at the PCR again.

The following figure illustrates the relationship between PCR, SCR and MBS.

**Figure 47** PCR, SCR and MBS in Traffic Shaping

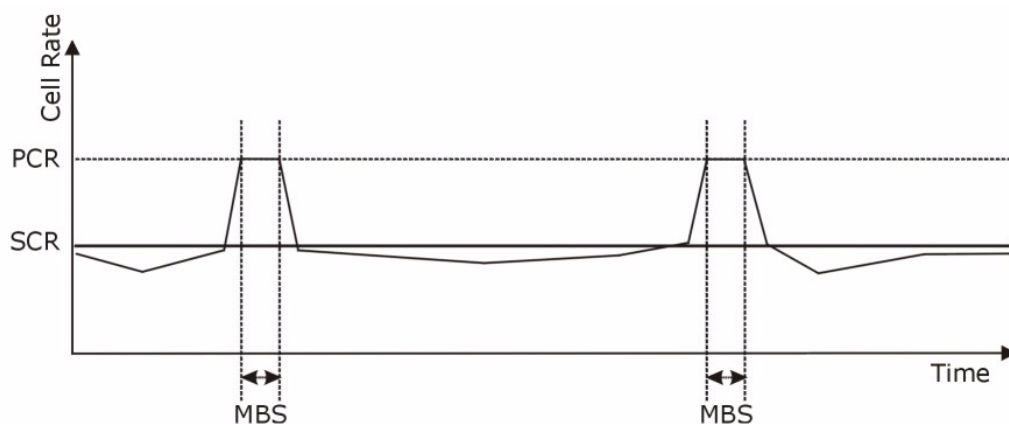

### 8.12.2.4 Cell Delay Variation Tolerance (CDVT)

Cell Delay Variation Tolerance (CDVT) is the accepted tolerance of the difference between a cell's transfer delay and the expected transfer delay. CDVT controls the time scale over which the PCR is enforced. CDVT is used to determine if a cell arrived too early in relation to PCR.

### 8.12.2.5 Burst Tolerance (BT)

Burst Tolerance (BT) is the maximum number of cells that the port is guaranteed to handle without any discards. BT controls the time scale over which the SCR is enforced. BT is used to determine if a cell arrived too early in relation to SCR. Use this formula to calculate BT:  $(MBS - 1) \times (1 / SCR - 1 / PCR) = BT$ .

### 8.12.2.6 Theoretical Arrival Time (TAT)

The Theoretical Arrival Time (TAT) is when the next cell (in an ATM connection's stream of cells) is expected to arrive. TAT is calculated based on the PCR or SCR.

The following figure illustrates the relationship between TAT, CDVT and BT. If a cell arrives at time A, then according to PCR or SCR, the next cell is expected to arrive at time B. If the next cell arrives earlier than time C, it is discarded or tagged for not complying with the TAT. Time C is calculated based on the CDVT or BT.

**Figure 48** TAT, CDVT and BT in Traffic Shaping

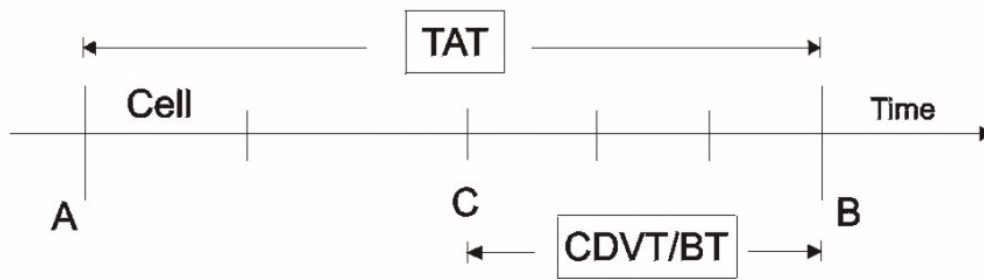

## 8.13 VC Profile Screen

Click **Basic Setting** and then **xDSL Profiles Setup** in the navigation panel and then **VC Profile** to open the following screen.

Figure 49 VC Profile

The following table describes the fields in this screen.

Table 19 VC Profile

LABEL	DESCRIPTION
Port Profile	Click <b>Port Profile</b> to configure port profiles and assign them to individual ports.
Alarm Profile	Click <b>Alarm Profile</b> to open the <b>Alarm Profile</b> screen where you can configure limits that trigger an alarm when exceeded.
IGMP Filter Profile	Click <b>IGMP Filter Profile</b> to open the <b>IGMP Filter Profile</b> screen where you can configure IGMP multicast filter profiles.
Index	This is the number of the VC profile.
Name	This name identifies the VC profile.
Encap	This field displays the profile's type of encapsulation ( <b>llc</b> or <b>vc</b> ).
AAL	The AAM ADSL ports' PVCs use ATM Adaptation Layer (AAL) 5.
Class	This field displays the type of ATM traffic class: <b>cbr</b> (constant bit rate), <b>vbr</b> (real-time variable bit rate), <b>nrt-vbr</b> (non-real time variable bit rate) or <b>ubr</b> (unspecified bit rate).
PCR	This is the Peak Cell Rate (PCR), the maximum rate at which the sender can send cells.
CDVT	This field displays the accepted tolerance of the difference between a cell's transfer delay and the expected transfer delay.
SCR	The Sustained Cell Rate (SCR) sets the average cell rate (long-term) that can be transmitted. SCR applies with the <b>vbr</b> traffic class. Minimum Cell Rate (MCR) is the minimum rate at which the sender can send cells.
BT	Burst Tolerance (BT) is the maximum number of cells that the port is guaranteed to handle without any discards. BT applies with the <b>vbr</b> traffic class.
Modify	Select a VC profile's <b>Select</b> radio button and click <b>Modify</b> to edit the VC profile.
Delete	Select a VC profile's <b>Select</b> radio button and click <b>Delete</b> to remove the VC profile.
The rest of the screen is for PVC configuration.	

**Table 19** VC Profile (continued)

LABEL	DESCRIPTION
Name	When editing a profile, this is the name of this profile. When adding a profile, type a name for the profile. You can use up to 31 ASCII characters; spaces are not allowed.
Encap	Select the encapsulation type ( <b>LLC</b> or <b>VC</b> ) for this port.
Class	Select <b>CBR</b> (constant bit rate) to specify fixed (always-on) bandwidth for voice or data traffic. Select <b>UBR</b> (unspecified bit rate) for applications that are non-time sensitive, such as e-mail. Select <b>VBR</b> (real time variable bit rate) or <b>NRT-VBR</b> (non real time variable bit rate) for bursty traffic and bandwidth sharing with other applications.
PCR	Divide the DSL line rate (bps) by 424 (the size of an ATM cell) to find the Peak Cell Rate (PCR). This is the maximum rate at which the sender can send cells. PCR applies with all of the ATM traffic classes. Type the PCR here.
CDVT	Cell Delay Variation Tolerance (CDVT) is the accepted tolerance of the difference between a cell's transfer delay and the expected transfer delay. CDVT applies with all of the ATM traffic classes. Type the CDVT here.
SCR	The Sustained Cell Rate (SCR) sets the average cell rate (long-term) that can be transmitted. Type the SCR, which must be less than the PCR. SCR applies with the <b>VBR</b> traffic classes.
BT	Burst Tolerance (BT) sets a maximum number of cells that the port is guaranteed to handle without any discards. Type the BT here. BT applies with the <b>VBR</b> traffic classes.
Add	Click <b>Add</b> to save your changes to the AAM's volatile memory. The AAM loses these changes if it is turned off or loses power, so use the <b>Config Save</b> link on the navigation panel to save your changes to the non-volatile memory when you are done configuring.
Cancel	Click <b>Cancel</b> to start configuring the screen again.

## 8.14 Alarm Profile Screen

Click **Basic Setting** and then **xDSL Profiles Setup** in the navigation panel and then **Alarm Profile** to open the following screen.

Alarm profiles define ADSL port alarm thresholds. The AAM sends an alarm trap and generates a syslog entry when the thresholds of the alarm profile are exceeded.

Use the top part of the screen (with the **Add** and **Cancel** buttons) to add or edit alarm profiles. The rest of the screen displays the configured alarm profiles.

Figure 50 Alarm Profile

**Alarm Profile**

[Port Profile](#)
[VC Profile](#)
[IGMP Filter Profile](#)

Name :

Threshold	ATU - C	ATU - R	Threshold	ATU - C	ATU - R
15 Min LOF ( sec )	<input type="text" value="0"/>	<input type="text" value="0"/>	Init Failure Trap	Active <input type="checkbox"/>	
15 Min LOS ( sec )	<input type="text" value="0"/>	<input type="text" value="0"/>	Fast Rate Up ( bps )	<input type="text" value="0"/>	<input type="text" value="0"/>
15 Min LOL ( sec )	<input type="text" value="0"/>		Fast Rate Down ( bps )	<input type="text" value="0"/>	<input type="text" value="0"/>
15 Min LPR	<input type="text" value="0"/>	<input type="text" value="0"/>	Interleave Rate Up ( bps )	<input type="text" value="0"/>	<input type="text" value="0"/>
15 Min ES ( sec )	<input type="text" value="0"/>	<input type="text" value="0"/>	Interleave Rate Down ( bps )	<input type="text" value="0"/>	<input type="text" value="0"/>
15 Min SES ( sec )	<input type="text" value="0"/>	<input type="text" value="0"/>			
15 Min UAS( sec )	<input type="text" value="0"/>	<input type="text" value="0"/>			
15 Min Failed Fast Retrain	<input type="text" value="0"/>				

Alarm profiles with xDSL port mapping

Please click the "-" to mapping a xDSL port to a new alarm profile.

Index	Name								Modify		Delete	
1	2	3	4	5	6	7	8	9	10	11	12	
1	DEFVAL								<a href="#">Modify</a>	<a href="#">Delete</a>		
V	V	V	V	V	V	V	V	V	V	V	V	

The following table describes the fields in this screen.

Table 20 Alarm Profile

LABEL	DESCRIPTION
Port Profile	Click <b>Port Profile</b> to open the <b>Port Profile</b> screen. Use the <b>Port Profile</b> screen to configure profiles of ADSL port settings (such as the transfer rate, interleave delay and signal to noise ratio settings).
VC Profile	Click <b>VC Profile</b> to open the <b>VC Profile</b> screen where you can configure virtual channel profiles.
IGMP Filter Profile	Click <b>IGMP Filter Profile</b> to open the <b>IGMP Filter Profile</b> screen where you can configure IGMP multicast filter profiles.
Name	Type a name to identify the alarm profile (you cannot change the name of the DEFVAL profile). You can use up to 31 ASCII characters; spaces are not allowed.
Add	Click <b>Add</b> to save your changes to the AAM's volatile memory. The AAM loses these changes if it is turned off or loses power, so use the <b>Config Save</b> link on the navigation panel to save your changes to the non-volatile memory when you are done configuring.
Cancel	Click <b>Cancel</b> to start configuring the screen again.
Threshold	Specify limits for the individual performance counters. The AAM sends an alarm tram and generates a syslog entry when one of these thresholds is exceeded. A value of 0 disables the alarm threshold.
ATU-C	These fields are for traffic coming from the subscriber's device to the AAM.
ATU-R	These fields are for traffic going from the AAM to the subscriber's device.
15 Min LOF (sec)	This field sets the limit for the number of Loss Of Frame seconds that are permitted to occur within 15 minutes.

**Table 20** Alarm Profile (continued)

LABEL	DESCRIPTION
15 Min LOS (sec)	This field sets the limit for the number of Loss Of Signal seconds that are permitted to occur within 15 minutes.
15 Min LOL (sec)	This field sets limit for the number of Loss Of Link seconds that are permitted to occur within 15 minutes.
15 Min LPR	This field sets the limit for the number of times a Loss of Power (on the ATUR) is permitted to occur within 15 minutes.
15 Min ES (sec)	This field sets the limit for the number of Errored Seconds that are permitted to occur within 15 minutes.
15 Min SES (sec)	This field sets the limit for the number of Severely Errored Seconds that are permitted to occur within 15 minutes.
15 Min UAS (sec)	This field sets the limit for the number of UnAvailable Seconds that are permitted to occur within 15 minutes.
15 Min Failed Fast Retrain	This field sets the limit for the number of failed fast retrains that are permitted within 15 minutes.
Init Failure Trap	Select <b>Active</b> to trigger an alarm for an initialization failure trap.
Fast Rate Up (bps)	Specify a rate in kilobits per second (kbps). If a fast mode connection's upstream transmission rate increases by more than this number, then a trap is sent.
Fast Rate Down (bps)	Specify a rate in kilobits per second (kbps). If a fast mode connection's downstream transmission rate decreases by more than this number, then a trap is sent.
Interleave Rate Up (bps)	Specify a rate in kilobits per second (kbps). If an interleave mode connection's upstream transmission rate increases by more than this number, then a trap is sent.
Interleave Rate Down (bps)	Specify a rate in kilobits per second (kbps). If an interleave mode connection's upstream transmission rate decreases by more than this number, then a trap is sent.
Alarm profiles with xDSL port mapping	After you add an alarm profile, you can click a port number's "-" symbol to map the xDSL port to that alarm profile. The port's "V" symbol in the alarm profile were it was previously mapped changes to "-".
Index	This is the index number of the alarm profile.
Name	This is the name of the alarm profile.
Modify	Click <b>Modify</b> to edit a profile.
Delete	Click <b>Delete</b> to remove a profile.

## 8.15 IGMP Filter Profile Screen

You can use the IGMP filter profiles to control access to a service that uses a specific multicast group (like a SIP server for example). Configure an IGMP filter profile that allows access to that multicast group. Then assign the IGMP filter profile to ADSL ports that are allowed to use the service.

Click **Basic Setting** and then **xDSL Profiles Setup** in the navigation panel and then **IGMP Filter Profile** to open the following screen.

The **DEFVAL** IGMP filter profile is assigned to all of the ADSL ports by default. It allows a port to join all multicast IP addresses (224.0.0.0~239.255.255.255). If you want to allow an ADSL subscriber access to only specific IGMP multicast groups, use the **IGMP Filter Profile** screen to configure a different profile and then assign it to the subscriber's ADSL port in the **XDSL Port Setting** screen (see [Figure 44 on page 87](#)).

The top of the screen displays the configured IGMP filter profiles. Use the bottom part of the screen (with the **Add** and **Cancel** buttons) to add or edit alarm profiles.

**Figure 51** IGMP Filter Profile

Index	Name	Delete
1	DEFVAL	<input type="checkbox"/>
2	g2	<input type="checkbox"/>

**Delete**

Name	Start IP	End IP
	0.0.0.0	0.0.0.0
	0.0.0.0	0.0.0.0
	0.0.0.0	0.0.0.0
	0.0.0.0	0.0.0.0
	0.0.0.0	0.0.0.0
	0.0.0.0	0.0.0.0
	0.0.0.0	0.0.0.0
	0.0.0.0	0.0.0.0
	0.0.0.0	0.0.0.0
	0.0.0.0	0.0.0.0
	0.0.0.0	0.0.0.0
	0.0.0.0	0.0.0.0
	0.0.0.0	0.0.0.0
	0.0.0.0	0.0.0.0
	0.0.0.0	0.0.0.0
	0.0.0.0	0.0.0.0
	0.0.0.0	0.0.0.0

**Add** **Cancel**

The following table describes the fields in this screen.

**Table 21** IGMP Filter Profile

LABEL	DESCRIPTION
Port Profile	Click <b>Port Profile</b> to configure port profiles and assign them to individual ports.
VC Profile	Click <b>VC Profile</b> to open the <b>VC Profile</b> screen where you can configure virtual channel profiles.
Alarm Profile	Click <b>Alarm Profile</b> to open the <b>Alarm Profile</b> screen where you can configure limits that trigger an alarm when exceeded.



The following table describes the fields in this screen.

**Table 22** Line Rate Information

LABEL	DESCRIPTION
Line Performance	Click <b>Line Performance</b> to display an ADSL port's line performance counters.
Line Data	Click <b>Line Data</b> to display an ADSL port's line bit allocation.
Port	Use this drop-down list box to select a port for which you wish to view information.
Refresh	Click <b>Refresh</b> to display updated information.
Port Name	This field displays the name of the ADSL port.
The rate fields display the transmission rates. "Line Down" indicates that the ADSL port is not connected to a subscriber.	
Down/up Stream Rate	These are the rates (in Kbps) at which the port has been sending and receiving data.
Down/up Stream Noise Margin	These are the DSL line's downstream and upstream noise margins. Measured in decibels (dB).
Down/up Stream Attenuation	These are the reductions in amplitude of the downstream and upstream DSL signals. Measured in decibels (dB).
Down/up Stream Attainable Rate	These are the highest theoretically possible transfer rates (in Kbps) at which the port could send and receive data.
Service Mode	This field displays the ADSL standard that the port is using: G.dmt, G.lite (AAM1212-51) or ANSI T1.413 issue 2 (AAM1212-51), ADSL2, ADSL2+, ETSI (AAM1212-53).
Trellis Encoding	This field displays whether Trellis encoding is turned on or off. Trellis encoding helps to reduce the noise in ADSL transmissions. Trellis may reduce throughput but it makes the connection more stable. <sup>a</sup>
Down Stream Interleave Delay	This field displays the number of milliseconds of interleave delay for downstream transmissions.
Up Stream Interleave Delay	This field displays the number of milliseconds of interleave delay for upstream transmissions.
Down Stream Output Power	This field displays the amount of power that this port is using to transmit to the subscriber's ADSL modem or router. The total output power of the transceiver varies with the length and line quality. The farther away the subscriber's ADSL modem or router is or the more interference there is on the line, the more power is needed.
Info	<p>The <b>Info Atur</b> fields show data acquired from the ATUR (ADSL Termination Unit – Remote), in this case the subscriber's ADSL modem or router, during negotiation/provisioning message interchanges. This information can help in identifying the subscriber's ADSL modem or router.</p> <p>The <b>Info Atuc</b> fields show data acquired from the ATUC (ADSL Termination Unit – Central), in this case AAM, during negotiation/provisioning message interchanges.</p> <p>The vendor ID, vendor version number and product serial number are obtained from vendor ID fields (see ITU-T G.994.1) or R-MSGS1 (see T1.413).</p>

a. At the time of writing, the AAM always uses Trellis coding.

## 8.17 Line Performance

Click **Basic Setting** and then **Line Data** in the navigation panel and then the **Line Performance** link to open the following screen. This screen displays an ADSL port's line performance counters.

These counters display line performance data that has been accumulated since the system started. The definitions of near end/far end are relative to the AAM. Downstream refers to the data that the AAM sends to the subscriber's device. Upstream refers to data that the AAM receives from the subscriber's device.

**Figure 53** Line Performance

15 min history		lofs	loss	lols	lprs	eSs	inits	sesl	uasl
Current	ATUC	0	0	0	-	0	0	0	0
	ATUR	0	0	-	0	0	-	0	0
Previous 1	ATUC	0	18	0	-	18	1	18	18
	ATUR	0	18	-	0	45	-	18	18

1 day history		lofs	loss	lols	lprs	eSs	inits	sesl	uasl
Current	ATUC	0	18	0	-	18	1	18	18
	ATUR	0	18	-	0	45	-	18	18
Previous	ATUC	0	0	0	-	0	0	0	0
	ATUR	0	0	-	0	0	-	0	0

The following table describes the fields in this screen.

**Table 23** Line Performance

LABEL	DESCRIPTION
Line Rate	Click <b>Line Rate</b> to display an ADSL port's line operating values.
Line Data	Click <b>Line Data</b> to display an ADSL port's line bit allocation.
Port	Use this drop-down list box to select a port for which you wish to view information.
Refresh	Click <b>Refresh</b> to display updated information.
Port Name	This field displays the name of the ADSL port.
Line Type	"Fast" stands for non-interleaved (fast mode) and "Interleaved: stands for interleaved mode.
Init	This displays how many times the AAM has initialized the DSL link.

**Table 23** Line Performance (continued)

LABEL	DESCRIPTION
Down/Up Stream BLKS	The number of Blocks transmitted (downstream) or received (upstream) on this ADSL port. A block is a set of consecutive bits associated with the path; each bit belongs to one and only one block. Consecutive bits may not be contiguous in time.
Down/Up Stream ES	The Number of Errored Seconds transmitted (downstream) or received (upstream) on this ADSL port.
Down/Up Stream SES	The Number of Severely Errored Seconds transmitted (downstream) or received (upstream) on this ADSL port. Severely errored seconds contained 30% or more errored blocks or at least one defect. This is a subset of the <b>Down/Up Stream ES</b> .
Down/Up Stream UAS	The downstream or upstream number of UnAvailable Seconds.
Fast FEBE	In fast mode, the number of Far End Block Errors.
Fast NEBE	In fast mode, the number of Near End Block Errors.
Fast FE FEC	In fast mode, the number of Far End Forward Error Count.
Fast NE FEC	In fast mode, the number of Near End Forward Error Count.
Interleaved FEBE	In interleaved mode, the number of Far End Block Errors.
Interleaved NEBE	In interleaved mode, the number of Near End Block Errors.
Interleaved FE FEC	In interleaved mode, the number of Far End Forward Error Count.
Interleaved NE FEC	In interleaved mode, the number of Near End Forward Error Count.
LPR	This is the number of times that the subscriber's ADSL device has experienced a Loss of Power (been off).
15 min, 1day history	This section of the screen displays line performance statistics for the current and previous 15-minute periods, as well as for the current and previous 24 hours.
ATUC	These statistics are for the connection (or traffic) coming from the subscriber's device to the AAM.
ATUR	These statistics are for the connection (or traffic) going from the AAM to the subscriber's device.
lofs	The number of Loss Of Frame Seconds that have occurred within the period.
loss	The number of Loss Of Signal Seconds that have occurred within the period.
lols	The number of Loss Of Link seconds that have occurred within the period.
lprs	The number of loss of PoweR Seconds that have occurred within the period.
eSs	The number of Errored SecondS that have occurred within the period.
inits	The number of initialization failure traps that have occurred within the period.
sesl	The number of Severely Errored Seconds that have occurred within the period.
uasl	The number of UnAvailable Seconds that have occurred within the period.

### 8.17.1 Line Data

Click **Basic Setting** and **Line Data** in the navigation panel and then the **Line Data** link to open the following screen. This screen displays an ADSL port's line bit allocation.

Discrete Multi-Tone (DMT) modulation divides up a line's bandwidth into tones. This screen displays the number of bits transmitted for each tone. This can be used to determine the quality of the connection, whether a given sub-carrier loop has sufficient margins to support ADSL transmission rates, and possibly to determine whether certain specific types of interference or line attenuation exist. Refer to the ITU-T G.992.1 recommendation for more information on DMT.

The better (or shorter) the line, the higher the number of bits transmitted for a DMT tone. The maximum number of bits that can be transmitted per DMT tone is 15.

The bit allocation contents are only valid when the link is up.

In the screen shown, the downstream channel is carried on tones 48 to 255 and the upstream channel is carried on tones 16 to 31 (space is left between the channels to avoid interference).

**Figure 54** Line Data

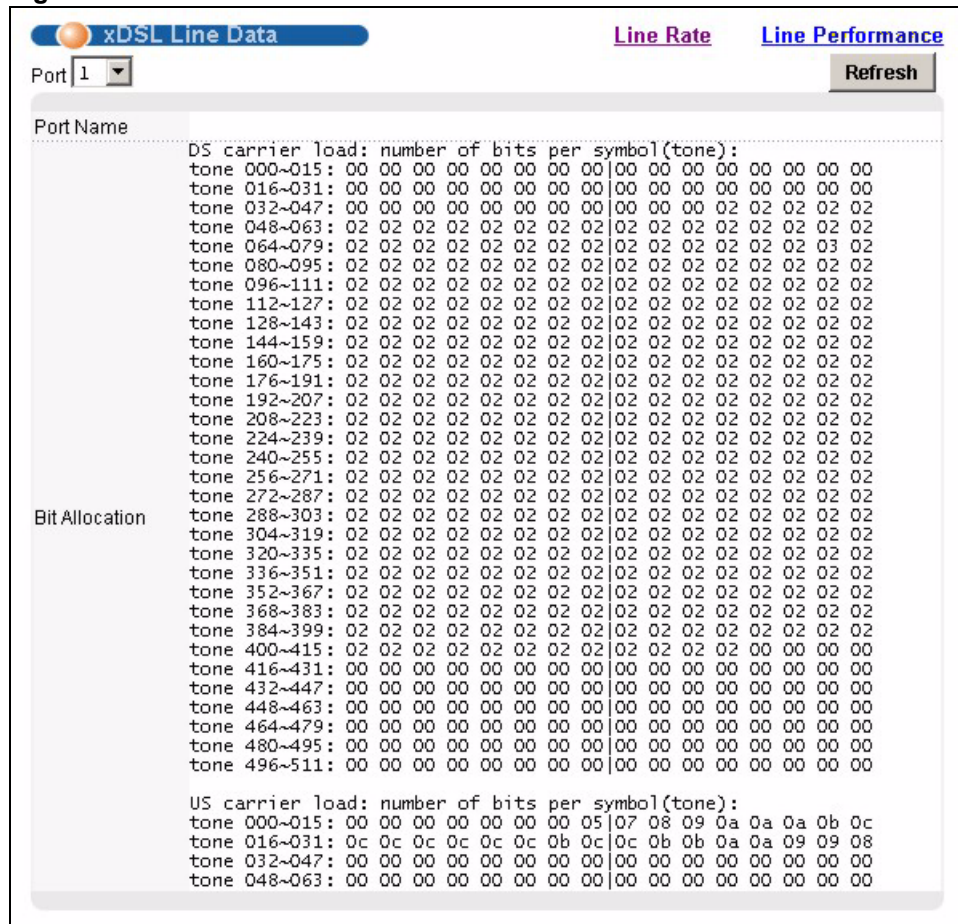

The following table describes the fields in this screen.

**Table 24** Line Data

LABEL	DESCRIPTION
Line Rate	Click <b>Line Rate</b> to display an ADSL port's line operating values.
Line Performance	Click <b>Line Performance</b> to display an ADSL port's line performance counters.
Port	Use this drop-down list box to select a port for which you wish to view information.
Refresh	Click <b>Refresh</b> to display updated information.
Port Name	This field displays the name of the ADSL port.
Bit Allocation	"DS carrier load" displays the number (in hexadecimal format) of bits transmitted per DMT tone for the downstream channel (from the AAM to the subscriber's DSL modem or router). "US carrier load" displays the number (in hexadecimal format) of bits received per DMT tone for the upstream channel (from the subscriber's DSL modem or router to the AAM).



# CHAPTER 9

## VLAN

This chapter shows you how to configure 802.1Q tagged VLANs.

### 9.1 Introduction to VLANs

A VLAN (Virtual Local Area Network) allows a physical network to be partitioned into multiple logical networks. Devices on a logical network belong to one group. A device can belong to more than one group. With VLAN, a device cannot directly talk to or hear from devices that are not in the same group(s); the traffic must first go through a router.

In MTU (Multi-Tenant Unit) applications, VLAN is vital in providing isolation and security among the subscribers. When properly configured, VLAN prevents one subscriber from accessing the network resources of another on the same LAN, thus a user will not see the printers and hard disks of another user in the same building. If you have enabled port isolation in the **Switch Setup** screen, you do not need to configure the VLAN to isolate subscribers.

VLAN also increases network performance by limiting broadcasts to a smaller and more manageable logical broadcast domain. In traditional switched environments, all broadcast packets go to each and every individual port. With VLAN, all broadcasts are confined to a specific broadcast domain.

Note that a VLAN is unidirectional; it only governs outgoing traffic.

### 9.2 Introduction to IEEE 802.1Q Tagged VLAN

Tagged VLAN uses an explicit tag (VLAN ID) in the MAC header to identify the VLAN membership of a frame across bridges - they are not confined to the switch on which they were created. The VLANs can be created statically by hand or dynamically through GVRP. The VLAN ID associates a frame with a specific VLAN and provides the information that switches need to process the frame across the network. A tagged frame is four bytes longer than an untagged frame and contains two bytes of TPID (Tag Protocol Identifier, residing within the type/length field of the Ethernet frame) and two bytes of TCI (Tag Control Information, starts after the source address field of the Ethernet frame).

The CFI (Canonical Format Indicator) is a single-bit flag, always set to zero for Ethernet switches. If a frame received at an Ethernet port has a CFI set to 1, then that frame should not be forwarded as it is to an untagged port. The remaining twelve bits define the VLAN ID, giving a possible maximum number of 4,096 (2<sup>12</sup>) VLANs. Note that user priority and VLAN ID are independent of each other. A frame with VID (VLAN Identifier) of null (0) is called a

priority frame, meaning that only the priority level is significant and the default VID of the ingress port is given as the VID of the frame. Of the 4096 possible VIDs, a VID of 0 is used to identify priority frames and value 4095 (FFF) is reserved, so the maximum possible VLAN configurations are 4,094.

TPID	User Priority	CFI	VLAN ID
2 Bytes	3 Bits	1 Bit	12 bits

The AAM handles up to 4094 VLANs (VIDs 1-4094). The switch accepts incoming frames with VIDs 1-4094.

## 9.2.1 Forwarding Tagged and Untagged Frames

Each port on the switch is capable of passing tagged or untagged frames. To forward a frame from an 802.1Q VLAN-aware switch to an 802.1Q VLAN-unaware switch, the switch first decides where to forward the frame and then strips off the VLAN tag. To forward a frame from an 802.1Q VLAN-unaware switch to an 802.1Q VLAN-aware switch, the switch first decides where to forward the frame, and then inserts a VLAN tag reflecting the ingress port's default VID. The default PVID is VLAN 1 for all ports, but this can be changed.

The egress (outgoing) port(s) of a frame is determined on the combination of the destination MAC address and the VID of the frame. For a unicast frame, the egress port based by the destination address must be a member of the VID, also; otherwise, the frame is blocked. For a broadcast frame, it is duplicated only on ports (except the ingress port itself) that are members of the VID, thus confining the broadcast to a specific domain.

Whether to tag an outgoing frame depends on the setting of the egress port on an individual VLAN and port basis (remember that a port can belong to multiple VLANs). If the tagging on the egress port is enabled for the VID of a frame, then the frame is transmitted as a tagged frame; otherwise, it is transmitted as an untagged frame.

## 9.3 Automatic VLAN Registration

GARP and GVRP are the protocols used to automatically register VLAN membership across switches.

### 9.3.1 GARP

GARP (Generic Attribute Registration Protocol) allows network switches to register and de-register attribute values with other GARP participants within a bridged LAN. GARP is a protocol that provides a generic mechanism for protocols that serve a more specific application, for example, GVRP.

### 9.3.1.1 GARP Timers

Switches join VLANs by making a declaration. A declaration is made by issuing a Join message using GARP. Declarations are withdrawn by issuing a Leave message. A Leave All message terminates all registrations. GARP timers set declaration timeout values.

### 9.3.2 GVRP

GVRP (GARP VLAN Registration Protocol) is a registration protocol that defines a way for switches to register necessary VLAN members on ports across the network. Enable this function to permit VLANs groups beyond the local switch.

Please refer to the following table for common IEEE 802.1Q VLAN terminology.

**Table 25** IEEE 802.1Q VLAN Terminology

VLAN PARAMETER	TERM	DESCRIPTION
VLAN Type	Permanent VLAN	This is a static VLAN created manually.
	Dynamic VLAN	This is a VLAN configured by a GVRP registration/deregistration process.
VLAN Administrative Control	Registration Fixed	Fixed registration ports are permanent VLAN members.
	Registration Forbidden	Ports with registration forbidden are forbidden to join the specified VLAN.
	Normal Registration	Ports dynamically join a VLAN using GVRP.
VLAN Tag Control	Tagged	Ports belonging to the specified VLAN tag all outgoing frames transmitted.
	Untagged	Ports belonging to the specified don't tag all outgoing frames transmitted.
VLAN Port	Port VID	This is the VLAN ID assigned to untagged frames that this port received.
	Acceptable frame type	You may choose to accept both tagged and untagged incoming frames or just tagged incoming frames on a port.
	Ingress filtering	If set, the switch discards incoming frames for VLANs that do not have this port as a member

## 9.4 VLAN Status

Click **Advanced Application** and then **VLAN** to display the **VLAN Status** screen as shown next.

**Figure 55** VLAN Status

Index	Status												Name / VID	
	1	2	3	4	5	6	7	8	9	10	11	12	enet1	enet2
1	Static												DEFAULT / 1	
0(days) : 3:44:40	U	U	U	U	U	U	U	U	U	U	U	U	U	U

Poll Interval(s)

Change Pages

The following table describes the labels in this screen.

**Table 26** VLAN Status

LABEL	DESCRIPTION
Static VLAN Setting	Click <b>Static VLAN Setting</b> to configure ports to dynamically join a VLAN group or permanently assign ports to a VLAN group or prohibit ports from joining a VLAN group.
VLAN Port Setting	Click <b>VLAN Port Setting</b> to specify Port VLAN IDs (PVIDs).
The Number Of VLAN	This is the number of VLANs configured on the AAM.
Page X of X	This identifies which page of VLAN status information is displayed and how many total pages of VLAN status information there are.
The first table displays the names of the fields. The subsequent tables show the settings of the VLANs.	
Index	This is the VLAN index number.
Status	This field shows how this VLAN was added to the AAM; dynamically using GVRP or statically, that is, added as a permanent entry.
Name / VID	The name identifies an individual VLAN. The vid is the PVID, the Port VLAN ID assigned to untagged frames or priority-tagged frames received on this port.
1~12, enet1, enet2	These columns display the VLAN's settings for each port. A tagged port is marked as <b>T</b> , an untagged port is marked as <b>U</b> and ports not participating in a VLAN are marked as "-".
Elapsed Time	This field shows how long it has been since a normal VLAN was registered or a static VLAN was set up.
Poll Interval(s)	The text box displays how often (in seconds) this screen refreshes. You may change the refresh interval by typing a new number in the text box and then clicking <b>Set Interval</b> .
Stop	Click <b>Stop</b> to halt polling statistics.
Change Pages	Click <b>Previous Page</b> or <b>Next Page</b> to show the preceding/following screen if the information cannot be displayed in one screen.

## 9.5 Static VLAN Setting

Click **Advanced** and then **VLAN** in the navigation panel and then the **Static VLAN Setting** link to display the screen as shown next.

You can assign a port to be a member of a VLAN group or prohibit a port from joining a VLAN group in this screen. This is an IEEE 802.1Q VLAN.

**Figure 56** Static VLAN Setting

The screenshot shows the 'Static VLAN Setting' interface. At the top, there are tabs for 'VLAN Status' and 'VLAN Port Setting'. Below these is a table with columns: VID, Active, Name, and Delete. The first row shows VID 1, Active Yes, Name DEFAULT, and a Delete checkbox. Below the table are 'Delete' and 'Cancel' buttons. Further down are input fields for 'Active' (checkbox), 'Name' (text box), and 'VLAN ID' (text box with range 0~4094). The main part of the screen is a table with columns: Port, Control, and Tagging. The Control column has sub-columns 'Select All' and 'Select All'. The Tagging column has sub-columns 'Select', 'All', and 'None'. The table lists ports ENET1, ENET2, and 1 through 12. For each port, there are radio buttons for 'Normal', 'Fixed', and 'Forbidden', and checkboxes for 'Tx Tagging'.

The following table describes the labels in this screen.

**Table 27** Static VLAN Setting

LABEL	DESCRIPTION
VLAN Status	Click <b>VLAN Status</b> to see which of the AAM's ports are members of which VLANs.
VLAN Port Setting	Click <b>VLAN Port Setting</b> to specify Port VLAN IDs (PVIDs).
VID	This field displays the ID number of the VLAN group. Click the number to edit the VLAN settings.
Active	This field indicates whether the VLAN settings are enabled ( <b>Yes</b> ) or disabled ( <b>No</b> ).
Name	This field displays the descriptive name for this VLAN group.

**Table 27** Static VLAN Setting (continued)

LABEL	DESCRIPTION
Delete	<p>Select the check boxes of the rules that you want to remove in the <b>Delete</b> column and then click the <b>Delete</b> button.</p> <p>You cannot delete a VLAN if any PVIDs are set to use the VLAN or the VLAN is the CPU (management) VLAN. The <b>DEFAULT</b> VLAN cannot be deleted when a port's PVID refers to it. The CPU VLAN also cannot be deleted.</p>
Cancel	Click <b>Cancel</b> to clear the <b>Delete</b> check boxes.
Active	<p>Select this check box to enable the VLAN.</p> <p>You cannot disable a VLAN if any PVIDs are set to use the VLAN or the VLAN is the CPU (management) VLAN.</p>
Name	Enter a descriptive name for this VLAN group for identification purposes.
VLAN ID	Enter the VLAN ID for this static VLAN entry; the valid range is between 1 and 4094.
Port	The port numbers identify the AAM's ports.
Control	<p>Select <b>Normal</b> for the port to dynamically join this VLAN group using GVRP. This is available for the Ethernet ports.</p> <p>Select <b>Fixed</b> for the port to be a permanent member of this VLAN group. Use the <b>Select All</b> button to include every port.</p> <p>Select <b>Forbidden</b> if you want to prohibit the port from joining this VLAN group. Use the <b>Select All</b> button to include every port.</p> <p>You cannot change a port from the fixed state to another state if the port's PVID is set to this VLAN. The VLAN must have at least one port set to the fixed status if the VLAN is the CPU (management) VLAN.</p>
Tagging	Select <b>Tx Tagging</b> if you want the port to tag all outgoing frames transmitted with this VLAN group ID. Use the <b>All</b> button to include every port. Use the <b>None</b> button to clear all of the ports' check boxes.
Add	<p>Click <b>Add</b> to save your settings. The VLAN then displays in the summary table at the top of the screen.</p> <p>Clicking <b>Add</b> saves your changes to the AAM's volatile memory. The AAM loses these changes if it is turned off or loses power, so use the <b>Config Save</b> link on the navigation panel to save your changes to the non-volatile memory when you are done configuring.</p>
Cancel	Click <b>Cancel</b> to begin configuring the screen again.

## 9.6 VLAN Port Setting

Click **Advanced** and then **VLAN** in the navigation panel and then the **VLAN Port Setting** link to display the screen as shown next.

Use this screen to specify port VLAN IDs and to set whether or not Ethernet ports propagate VLAN information to other switches.

Figure 57 VLAN Port Setting

Port	PVID	Priority	GVRP	Acceptable Frame Type
ENET1	1 (1-4094)	0	<input type="checkbox"/>	ALL
ENET2	1 (1-4094)	0	<input type="checkbox"/>	ALL
1	1 (1-4094)	0		All
2	1 (1-4094)	0		All
3	1 (1-4094)	0		All
4	1 (1-4094)	0		All
5	1 (1-4094)	0		All
6	1 (1-4094)	0		All
7	1 (1-4094)	0		All
8	1 (1-4094)	0		All
9	1 (1-4094)	0		All
10	1 (1-4094)	0		All
11	1 (1-4094)	0		All
12	1 (1-4094)	0		All

Apply Cancel Copy port 1 Paste

The following table describes the labels in this screen.

Table 28 VLAN Port Setting

LABEL	DESCRIPTION
VLAN Status	Click <b>VLAN Status</b> to see which of the AAM's ports are members of which VLANs.
Static VLAN Setting	Click <b>Static VLAN Setting</b> to configure ports to dynamically join a VLAN group or permanently assign ports to a VLAN group or prohibit ports from joining a VLAN group.
Port	The port numbers identify the AAM's ports.
PVID	Type the Port VLAN ID (PVID) from 1 to 4094. The AAM assigns the PVID to untagged frames or priority frames (0 VID) received on this port.
Priority	Select an IEEE 802.1p priority to assign to untagged frames or priority frames (0 VID) received on this port. See <a href="#">Table 11 on page 78</a> for more information on the priority levels.
GVRP	GVRP (GARP VLAN Registration Protocol) is a registration protocol that defines a way for switches to register necessary VLAN members on ports across the network. The AAM propagates VLAN information to other devices when this check box is selected. <sup>a</sup>
Acceptable Frame Type	Select <b>All</b> to have the port accept both tagged and untagged incoming frames. Select <b>Tag Only</b> to have the port only accept incoming frames that have a VLAN tag. Select <b>Untag Only</b> to have the port only accept incoming frames that do not have a VLAN tag. <sup>b</sup>
Apply	Click <b>Apply</b> to save your changes to the AAM's volatile memory. The AAM loses these changes if it is turned off or loses power, so use the <b>Config Save</b> link on the navigation panel to save your changes to the non-volatile memory when you are done configuring.

**Table 28** VLAN Port Setting (continued)

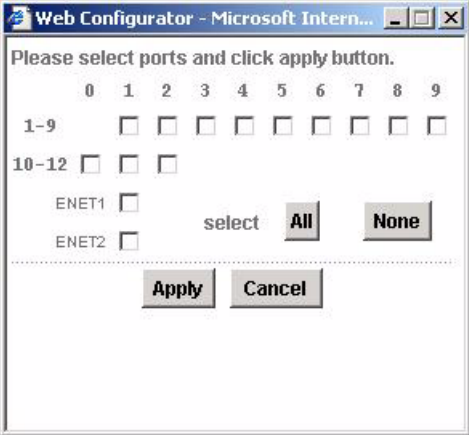
LABEL	DESCRIPTION
Cancel	Click <b>Cancel</b> to begin configuring this screen afresh.
Copy port	<p>Do the following to copy settings from one port to another port or ports.</p> <ol style="list-style-type: none"> <li>1. Select the number of the port from which you want to copy settings.</li> <li>2. Click <b>Paste</b> and the following screen appears.</li> <li>3. Select to which ports you want to copy the settings. Use <b>All</b> to select every port. Use <b>None</b> to clear all of the check boxes.</li> <li>4. Click <b>Apply</b> to paste the settings.</li> </ol> 

- a. At the time of writing, GVRP is available on the Ethernet ports.
- b. At the time of writing, the VLAN **Acceptable Frame Type** field is read-only for the Ethernet ports. The AAM accepts both tagged and untagged incoming frames on the Ethernet ports.

# CHAPTER 10

## IGMP Snooping

This chapter describes the **IGMP Snooping** screen.

### 10.1 IGMP Snooping

IGMP (Internet Group Multicast Protocol) is a session-layer protocol used to establish membership in a multicast group - it is not used to carry user data. Refer to RFC 1112 and RFC 2236 for information on IGMP versions 1 and 2 respectively.

A switch can passively snoop on IGMP Query, Report and Leave (IGMP version 2) packets transferred between IP multicast routers/switches and IP multicast hosts to learn the IP multicast group membership. It checks IGMP packets passing through it, picks out the group registration information, and configures multicasting accordingly. IGMP snooping allows the switch to learn multicast groups without you having to manually configure them.

The switch forwards multicast traffic destined for multicast groups (that it has learned from IGMP snooping or that you have manually configured) to ports that are members of that group. The switch discards multicast traffic destined for multicast groups that it does not know. IGMP snooping generates no additional network traffic, allowing you to significantly reduce multicast traffic passing through your switch.

### 10.2 IGMP Snooping Screen

Click **Advanced Application** and then **IGMP Snooping** in the navigation panel to display the **IGMP Snooping** screen as shown next. Use this screen to turn IGMP snooping off or on and view information collected by IGMP snooping.

**Figure 58** IGMP Snooping

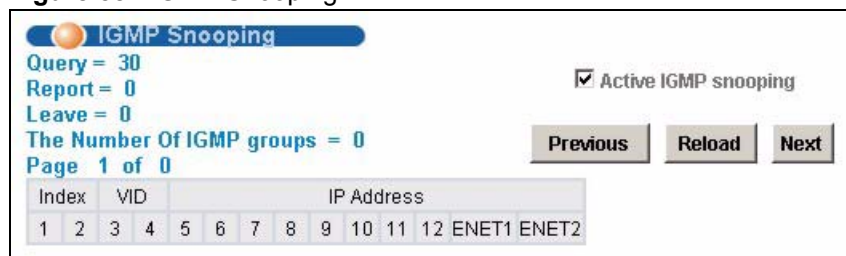

The following table describes the labels in this screen.

**Table 29** IGMP Snooping

<b>LABEL</b>	<b>DESCRIPTION</b>
Query	This is the total number of Query packets received.
Report	This is the total number of Report packets received.
Leave	This is the total number of Leave packets received.
The Number Of IGMP Groups	This is the number of IGMP groups that the AAM has identified on the local network.
Page X of X	This identifies which page of information is displayed and the total number of pages of information.
Previous/Next	Click one of these buttons to show the previous/next screen if all of the information cannot be seen in one screen.
Reload	Click this button to refresh the screen.
The first table displays the names of the fields. The subsequent tables show the settings of the IGMP groups.	
Index	This is the IGMP group index number.
VID	The VID is the PVID, the Port VLAN ID assigned to untagged frames or priority-tagged frames received on this port.
IP Address	This is the IP address of an IP multicast group member.
1~12, ENET1, ENET2	These columns display which ports are members of the IGMP snooping group.

# CHAPTER 11

## Static Multicast

This chapter describes the **Static Multicast** screen.

### 11.1 Static Multicast Filter

Use the static multicast filter to allow incoming frames based on multicast MAC address(es) that you specify. This feature can be used in conjunction with IGMP snooping to allow multicast MAC address(es) that are not learned by IGMP snooping. Use the static multicast filter to pass routing protocols, such as RIP and OSPF.

### 11.2 Static Multicast Screen

Click **Advanced Application** and then **Static Multicast** in the navigation panel to display the **Static Multicast** screen as shown next.

**Figure 59** Static Multicast

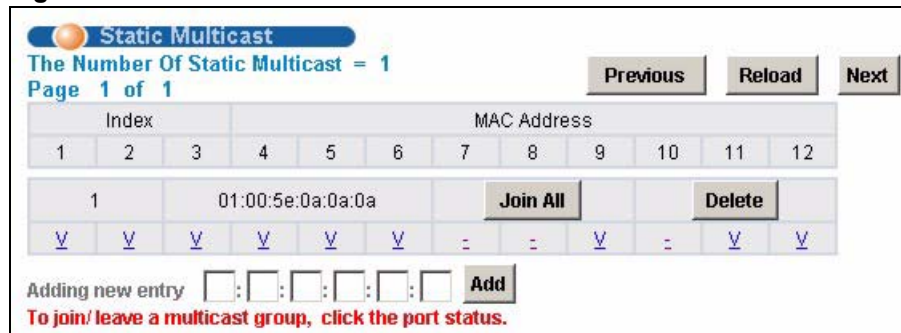

The following table describes the related labels in this screen.

**Table 30** Static Multicast

LABEL	DESCRIPTION
The Number Of Static Multicast	This is the number of static multicast filters configured on the AAM.
Page X of X	This identifies which page of information is displayed and the total number of pages of information.
Previous/Next	Click one of these buttons to show the previous/next screen if all status information cannot be seen in one screen.
Reload	Click this button to refresh the screen.

**Table 30** Static Multicast (continued)

LABEL	DESCRIPTION
The first table displays the names of the fields. The subsequent tables show the settings of the IGMP groups.	
Index	This is the static multicast group index number.
MAC Address	This is the multicast MAC address.
1~12	These fields display the static multicast group membership status of the ADSL ports. "V" displays for members and "-" displays for non-members. Click an ADSL port's status to change it (clicking a "V" changes it to "-" and vice versa).
Join All	Click <b>Join All</b> to make all of the ADSL ports members of the static multicast group.
Delete	Click <b>Delete</b> to remove a static multicast group.
Adding new entry	Type a multicast MAC address in the field and click the <b>Add</b> button to create a new static multicast filter entry. Clicking <b>Add</b> saves your changes to the AAM's volatile memory. The AAM loses these changes if it is turned off or loses power, so use the <b>Config Save</b> link on the navigation panel to save your changes to the non-volatile memory when you are done configuring.

# CHAPTER 12

## Packet Filtering

This chapter describes how to configure the **Packet Filter** screen.

### 12.1 Packet Filter Configuration

Click **Advanced Application** and then **Filtering** in the navigation panel to display the **Packet Filter** screen as shown next. Use this screen to set which types of packets the AAM accepts on individual ADSL ports.

**Figure 60** Packet Filter

Port	PPPoE	IP	ARP	NetBios	DHCP	EAPOL	IGMP	PPPoE Only
1	V	V	V	V	V	V	V	-
2	V	V	V	V	V	V	V	-
3	V	V	V	V	V	V	V	-
4	V	V	V	V	V	V	V	-
5	V	V	V	V	V	V	V	-
6	V	V	V	V	V	V	V	-
7	V	V	V	V	V	V	V	-
8	#	#	#	#	#	#	#	V
9	V	V	V	V	V	V	V	-
10	V	V	V	V	V	V	V	-
11	V	V	V	V	V	V	V	-
12	V	V	V	V	V	V	V	-

The following table describes the labels in this screen.

**Table 31** Packet Filter

LABEL	DESCRIPTION
Port	Use this drop-down list box to select an ADSL port for which you wish to configure packet type filtering.
	Select the check boxes of the types of packets to accept on the ADSL port.

**Table 31** Packet Filter (continued)

LABEL	DESCRIPTION
PPPoE Only	Select this check box to allow only PPPoE traffic. This will gray out the check boxes for other packet types and the AAM will drop any non-PPPoE packets.
PPPoE Pass through	Point-to-Point Protocol over Ethernet relies on PPP and Ethernet. It is a specification for connecting the users on an Ethernet to the Internet through a common broadband medium, such as a single DSL line, wireless device or cable modem.
IP Pass through	Internet Protocol. The underlying protocol for routing packets on the Internet and other TCP/IP-based networks.
ARP Pass through	Address Resolution Protocol is a protocol for mapping an Internet Protocol address (IP address) to a physical computer address that is recognized in the local network.
NetBios Pass through	NetBIOS (Network Basic Input/Output System) are TCP or UDP packets that enable a computer to find other computers.
DHCP Pass through	Dynamic Host Configuration Protocol automatically assigns IP addresses to clients when they log on. DHCP centralizes IP address management on central computers that run the DHCP server program. DHCP leases addresses, for a period of time, which means that past addresses are "recycled" and made available for future reassignment to other systems.
EAPOL Pass through	EAP (Extensible Authentication Protocol, RFC 2486) over LAN. EAP is used with IEEE 802.1x to allow additional authentication methods (besides RADIUS) to be deployed with no changes to the access point or the wireless clients.
IGMP Pass through	Internet Group Multicast Protocol is used when sending packets to a specific group of hosts.
Add	Click <b>Add</b> to save your settings. The VLAN then displays in the summary table at the top of the screen.  Clicking <b>Add</b> saves your changes to the AAM's volatile memory. The AAM loses these changes if it is turned off or loses power, so use the <b>Config Save</b> link on the navigation panel to save your changes to the non-volatile memory when you are done configuring.
Cancel	Click <b>Cancel</b> to begin configuring the screen again.
This table shows the ADSL port packet filter settings.	
Port	These are the numbers of the ADSL ports. Click this number to edit the port's filter settings.
PPPoE, IP, ARP, NetBios, DHCP, EAPO, IGMP, PPPoE Only	These are the packet filter settings for each port.  "V" displays for the packet types that the AAM is to accept on the port. "." displays for packet types that the AAM is to reject on the port. "#" displays for the packet filter settings that the AAM ignores.

# CHAPTER 13

## MAC Filter

This chapter introduces the MAC filter.

### 13.1 MAC Filter Introduction

Use the MAC filter to allow only frames from MAC (Media Access Control) address(es) that you specify to come in through a port.

### 13.2 MAC Filter Configuration

Click **Advanced Application** and then **MAC Filter** in the navigation panel to display the **MAC Filter** screen as shown next.

**Figure 61** MAC Filter

MAC Filter

Only listed MAC can pass through the port if set.

Port: 1    MAC: [ ][ ][ ][ ][ ][ ]

Add    Cancel

Port	Active	MAC	Delete
1	<input type="checkbox"/>		
2	<input type="checkbox"/>		
3	<input type="checkbox"/>		
4	<input type="checkbox"/>		
5	<input type="checkbox"/>		
6	<input type="checkbox"/>		
7	<input type="checkbox"/>		
8	<input type="checkbox"/>		
9	<input type="checkbox"/>		
10	<input type="checkbox"/>		
11	<input type="checkbox"/>		
12	<input type="checkbox"/>		

Apply

The following table describes the labels in this screen.

**Table 32** MAC Filter

LABEL	DESCRIPTION
Port	Use this drop-down list box to select an ADSL port for which you wish to configure MAC filtering.
MAC	Type a device's MAC address in hexadecimal notation (xx:xx:xx:xx:xx:xx, where x is a number from 0 to 9 or a letter from a to f) in this field. The MAC address must be a valid MAC address. You may specify up to ten MAC addresses per port.
Add	Click <b>Add</b> to save your changes to the AAM's volatile memory. The AAM loses these changes if it is turned off or loses power, so use the <b>Config Save</b> link on the navigation panel to save your changes to the non-volatile memory when you are done configuring.
Cancel	Click <b>Cancel</b> to begin configuring this screen afresh.
Port	These are the numbers of the ADSL ports.
Active	Select this check box to turn on MAC filtering for a port.
MAC	This field lists the MAC addresses that are set for this port.
Delete	Click <b>Delete</b> to remove a MAC address from the list.
Apply	Click <b>Apply</b> to save your changes to the AAM's volatile memory. The AAM loses these changes if it is turned off or loses power, so use the <b>Config Save</b> link on the navigation panel to save your changes to the non-volatile memory when you are done configuring.

# CHAPTER 14

## Spanning Tree Protocol

This chapter introduces the Rapid Spanning Tree Protocol (RSTP).

### 14.1 RSTP (Rapid Spanning Tree Protocol) and STP (Spanning Tree Protocol)

RSTP adds rapid reconfiguration capability to STP. The switch supports RSTP and the earlier STP. RSTP and STP detect and break network loops and provide backup links between switches, bridges or routers. They allow a device to interact with other RSTP or STP-aware devices in your network to ensure that only one path exists between any two stations on the network. The switch uses RSTP by default but can still interoperate with STP switches (although without RSTP's benefits).

The root bridge is the base of the spanning tree; it is the bridge with the lowest identifier value (MAC address). Path cost is the cost of transmitting a frame onto a LAN through that port. It is assigned according to the speed of the link to which a port is attached. The slower the media, the higher the cost - see the following table.

**Table 33** STP Path Costs

	LINK SPEED	RECOMMENDED VALUE	RECOMMENDED RANGE	ALLOWED RANGE
Path Cost	4Mbps	250	100 to 1000	1 to 65535
Path Cost	10Mbps	100	50 to 600	1 to 65535
Path Cost	16Mbps	62	40 to 400	1 to 65535
Path Cost	100Mbps	19	10 to 60	1 to 65535
Path Cost	1Gbps	4	3 to 10	1 to 65535
Path Cost	10Gbps	2	1 to 5	1 to 65535

On each bridge, the root port is the port through which this bridge communicates with the root. It is the port on this switch with the lowest path cost to the root (the root path cost). If there is no root port, then this switch has been accepted as the root bridge of the spanning tree network.

For each LAN segment, a designated bridge is selected. This bridge has the lowest cost to the root among the bridges connected to the LAN.

After a bridge determines the lowest cost-spanning tree with RSTP, it enables the root port and the ports that are the designated ports for the connected LANs, and disables all other ports that participate in RSTP. Network packets are therefore only forwarded between enabled ports, eliminating any possible network loops.

**Figure 62** STP Root Ports and Designated Ports

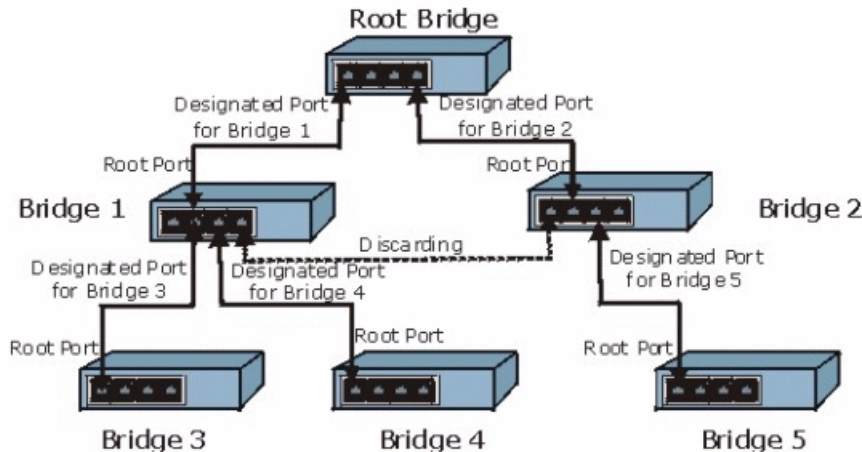

RSTP-aware devices exchange Bridge Protocol Data Units (BPDUs) periodically. When the bridged LAN topology changes, a new spanning tree is constructed.

In RSTP, the devices send BPDUs every Hello Time. If an RSTP-aware device does not get a Hello BPDU after three Hello Times pass (or the Max Age), the device assumes that the link to the neighboring bridge is down. This device then initiates negotiations with other devices to reconfigure the network to re-establish a valid network topology.

In STP, once a stable network topology has been established, all devices listen for Hello BPDUs transmitted from the root bridge. If an STP-aware device does not get a Hello BPDU after a predefined interval (Max Age), the device assumes that the link to the root bridge is down. This device then initiates negotiations with other devices to reconfigure the network to re-establish a valid network topology.

RSTP assigns three port states to eliminate packet looping while STP assigns five (see following table). A device port is not allowed to go directly from blocking state to forwarding state so as to eliminate transient loops.

**Table 34** RSTP Port States

RSTP PORT STATE	STP PORT STATE	DESCRIPTION
Discarding	Disabled	STP is disabled (default).
Discarding	Blocking	Only configuration and management BPDUs are received and processed.
Discarding	Listening	All BPDUs are received and processed.

**Table 34** RSTP Port States

RSTP PORT STATE	STP PORT STATE	DESCRIPTION
Learning	Learning	All BPDUs are received and processed. Information frames are submitted to the learning process but not forwarded.
Forwarding	Forwarding	All BPDUs are received and processed. All information frames are received and forwarded.

## 14.2 STP Status

Click **Advanced Application, Spanning Tree Protocol** in the navigation panel to display the status screen as shown next.

**Figure 63** Spanning Tree Protocol: Status

**Spanning Tree Protocol Status** [STP Config](#)

Spanning Tree Protocol : On

Bridge Status	
Our bridge ID	8000-001349bade21
Designated root ID	8000-001349bade21
Topology change times	0
Time since change	0:00:05
Cost to root	0
Root port ID	0x0000
Root max age (second)	20
Root hello time (second)	2
Root forward delay (second)	15
Max age (second)	20
Hello time (second)	2
Forward delay (second)	15

Port Status	ENET1	ENET2
State	discarding	Disabled
Port ID	0x800d	-
Path cost	4	-
Cost to root	0	-
Designated bridge	0000-000000000000	-
Designated port	0x0000	-

Poll Interval(s)

The following table describes the labels in this screen.

**Table 35** Spanning Tree Protocol: Status

LABEL	DESCRIPTION
STP Config	Click <b>STP Config</b> to modify the AAM's STP settings.
Spanning Tree Protocol	This field displays <b>On</b> if STP is activated. Otherwise, it displays <b>Off</b> .

**Table 35** Spanning Tree Protocol: Status (continued)

LABEL	DESCRIPTION
Our bridge ID	This is the unique identifier for this bridge, consisting of bridge priority plus MAC address. This ID is the same in <b>Designated root ID</b> if the AAM is the root switch.
Designated root ID	This is the unique identifier for the root bridge, consisting of bridge priority plus MAC address. This ID is the same in <b>Our bridge ID</b> if the AAM is the root switch.
Topology change times	This is the number of times the spanning tree has been reconfigured.
Time since change	This is the time since the spanning tree was last reconfigured.
Cost to root	This is the path cost from the root port on this AAM to the root switch.
Root port ID	This is the priority and number of the port on the AAM through which this AAM must communicate with the root of the Spanning Tree. "0x0000" displays when this device is the root switch.
Root max age (second)	This is the maximum time (in seconds) the root switch can wait without receiving a configuration message before attempting to reconfigure.
Root hello time (second)	This is the time interval (in seconds) at which the root switch transmits a configuration message. The root bridge determines <b>Hello Time</b> , <b>Max Age</b> and <b>Forwarding Delay</b> .
Root forward delay (second)	This is the time (in seconds) the root switch will wait before changing states (that is, listening to learning to forwarding).
Max age (second)	This is the maximum time (in seconds) the AAM can wait without receiving a configuration message before attempting to reconfigure.
Hello time (second)	This is the time interval (in seconds) at which the AAM transmits a configuration message. The root bridge determines <b>Hello Time</b> , <b>Max Age</b> and <b>Forwarding Delay</b> .
Forward delay (second)	This is the time (in seconds) the AAM will wait before changing states (that is, listening to learning to forwarding).
Port Status	This identifies the AAM's ports that support the use of STP.
State	This field displays the port's RSTP (or STP) state. With RSTP, the state can be <b>discarding</b> , <b>learning</b> or <b>forwarding</b> . With STP, the state can be <b>disabled</b> , <b>blocking</b> , <b>listening</b> , <b>learning</b> , or <b>forwarding</b> . <b>Disabled</b> appears when RSTP has not been turned on for the individual port or the whole device.
Port ID	This is the priority and number of the port on the AAM through which this AAM must communicate with the root of the Spanning Tree. "0x0000" displays when this device is the root switch.
Path cost	This is the path cost from this port to the root switch.
Cost to root	This is the path cost from the root port on this AAM to the root switch.
Designated bridge	This is the unique identifier for the bridge that has the lowest path cost to reach the root bridge, consisting of bridge priority plus MAC address.
Designated port	This is the port on the designated bridge that has the lowest path cost to reach the root bridge, consisting of bridge priority.
Poll Interval(s)	The text box displays how often (in seconds) this screen refreshes. You may change the refresh interval by typing a new number in the text box and then clicking <b>Set Interval</b> .
Stop	Click <b>Stop</b> to halt STP statistic polling.

## 14.2.1 Configure STP

Click **Advanced Application** and then **Spanning Tree Protocol** in the navigation panel to display the STP status.

Click **STP Config** to display the **Spanning Tree Protocol Configuration** screen as shown next.

**Figure 64** Spanning Tree Protocol: Configuration

Port	Active	Priority(0-255)	Path Cost(1-65535)
ENET1	<input checked="" type="checkbox"/>	128	4
ENET2	<input type="checkbox"/>	128	4

The following table describes the labels in this screen.

**Table 36** Spanning Tree Protocol: Configuration

LABEL	DESCRIPTION
STP Status	Click <b>STP Status</b> to display the AAM's STP status.
Active	Select this check box to turn on RSTP.  <b>Note:</b> It is recommended that you only use STP when you use the AAM in standalone mode with a network topology that has loops.
Bridge Priority	Bridge priority is used in determining the root switch, root port and designated port. The switch with the highest priority (lowest numeric value) becomes the STP root switch. If all switches have the same priority, the switch with the lowest MAC address will then become the root switch. The allowed range is 0 to 61440.  The lower the numeric value you assign, the higher the priority for this bridge.  Bridge Priority determines the root bridge, which in turn determines Hello Time, Max Age and Forwarding Delay.
Hello Time	This is the time interval in seconds between BPDU (Bridge Protocol Data Units) configuration message generations by the root switch. The allowed range is 1 to 10 seconds.

**Table 36** Spanning Tree Protocol: Configuration (continued)

LABEL	DESCRIPTION
MAX Age	This is the maximum time (in seconds) a switch can wait without receiving a BPDU before attempting to reconfigure. All switch ports (except for designated ports) should receive BPDUs at regular intervals. Any port that ages out STP information (provided in the last BPDU) becomes the designated port for the attached LAN. If it is a root port, a new root port is selected from among the switch ports attached to the network. The allowed range is 6 to 40 seconds.
Forwarding Delay	This is the maximum time (in seconds) a switch will wait before changing states. This delay is required because every switch must receive information about topology changes before it starts to forward frames. In addition, each port needs time to listen for conflicting information that would make it return to a blocking state; otherwise, temporary data loops might result. The allowed range is 4 to 30 seconds. As a general rule: $2 * (\text{Forward Delay} - 1) \geq \text{Max Age} \geq 2 * (\text{Hello Time} + 1)$
Port	This field identifies the Ethernet port.
Active	Select this check box to activate STP on this port.
Priority	Configure the priority for each port here. Priority decides which port should be disabled when more than one port forms a loop in a switch. Ports with a higher priority numeric value are disabled first. The allowed range is between 0 and 255 and default value is 128.
Path Cost	Path cost is the cost of transmitting a frame on to a LAN through that port. It is assigned according to the speed of the bridge. The slower the media, the higher the cost.
Apply	Click <b>Apply</b> to save your changes to the AAM's volatile memory. The AAM loses these changes if it is turned off or loses power, so use the <b>Config Save</b> link on the navigation panel to save your changes to the non-volatile memory when you are done configuring.
Cancel	Click <b>Cancel</b> to begin configuring this screen afresh.

# CHAPTER 15

## Port Authentication

This chapter describes the 802.1x authentication method and RADIUS server connection setup.

### 15.1 Introduction to Authentication

IEEE 802.1X is an extended authentication protocol<sup>1</sup> that allows support of RADIUS (Remote Authentication Dial In User Service, RFC 2138, 2139) for centralized user profile management on a network RADIUS server.

#### 15.1.1 RADIUS

RADIUS (Remote Authentication Dial-In User Service) authentication is a popular protocol used to authenticate users by means of an external server instead of (or in addition to) an internal device user database that is limited to the memory capacity of the device. In essence, RADIUS authentication allows you to validate an unlimited number of users from a central location.

**Figure 65** RADIUS Server



#### 15.1.2 Introduction to Local User Database

By storing user profiles locally on the AAM, your AAM is able to authenticate users without interacting.

### 15.2 Port Authentication Configuration

Click **Advanced Application** and **Port Authentication** in the navigation panel to display the screen as shown.

- 
1. Not all Windows operating systems support IEEE 802.1X (see the Microsoft web site for details). For other operating systems, see its documentation. If your operating system does not support IEEE 802.1X, then you may need to install IEEE 802.1X client software.

**Figure 66** Port Authentication: RADIUS

**RADIUS** [802.1x](#)

Enable Authentication Server

IP address: 0.0.0.0

UDP Port: 1812 (0-65535)

Shared Secret: 1234

**Apply**

Enable Local Profile Setting. ( Support up to 64 profiles)

Name: \_\_\_\_\_

Password: \_\_\_\_\_

Retype Password to confirm: \_\_\_\_\_

**Add** **Cancel**

Index	Name	Delete
1	admin	<input type="checkbox"/>

**Delete** **Cancel**

The following table describes the labels in this screen.

**Table 37** Port Authentication: RADIUS

LABEL	DESCRIPTION
802.1x	Click <b>802.1x</b> to configure individual port authentication settings.
Enable Authentication Server	Select this check box to have the AAM use an external RADIUS server to authenticate users.
IP address	Enter the IP address of the external RADIUS server in dotted decimal notation.
UDP Port	The default port of the RADIUS server for authentication is <b>1812</b> . You need not change this value unless your network administrator instructs you to do so.
Shared Secret	Specify a password (up to 31 alphanumeric characters) as the key to be shared between the external RADIUS server and the AAM. This key is not sent over the network. This key must be the same on the external RADIUS server and the AAM.
Apply	Click <b>Apply</b> to save your changes to the AAM's volatile memory. The AAM loses these changes if it is turned off or loses power, so use the <b>Config Save</b> link on the navigation panel to save your changes to the non-volatile memory when you are done configuring.
Enable Local Profile Setting	Select this check box to have the AAM use its internal database of user names and passwords to authenticate users.
Name	Type the user name of the user profile. You can enter up to 31 ASCII characters; spaces are not allowed.
Password	Type a password for this user profile. You can enter up to 31 ASCII characters; spaces are not allowed.
Retype Password to confirm	Type the password again to make sure you have entered it properly.
Add	Click <b>Add</b> to save your changes to the AAM's volatile memory. The AAM loses these changes if it is turned off or loses power, so use the <b>Config Save</b> link on the navigation panel to save your changes to the non-volatile memory when you are done configuring.

**Table 37** Port Authentication: RADIUS (continued) (continued)

LABEL	DESCRIPTION
Cancel	Click <b>Cancel</b> to begin configuring this screen afresh.
This table displays the configured user profiles.	
Index	These are the numbers of the user profiles. Click this number to edit the user profile.
Name	This is the user name of the user profile.
Delete	Select a user profile's <b>Delete</b> check box and click <b>Delete</b> to remove the user profile.
Cancel	Click <b>Cancel</b> to begin configuring this screen afresh and clear any selected <b>Delete</b> check boxes.

## 15.2.1 IEEE 802.1x Configuration

Click **Advanced Application** and **Port Authentication** in the navigation panel and then the **802.1x** link to display the screen as shown.

**Figure 67** Port Authentication: 802.1x

802.1x
Authentication: **RADIUS/Local Profile**

Enable

**Apply** **Cancel**

Port	Enable	Control	Reauthentication	Reauthentication Period( s)
1	<input type="checkbox"/>	AUTO	On	3600 (60~65535)
2	<input type="checkbox"/>	AUTO	On	3600 (60~65535)
3	<input type="checkbox"/>	AUTO	On	3600 (60~65535)
4	<input type="checkbox"/>	AUTO	On	3600 (60~65535)
5	<input type="checkbox"/>	AUTO	On	3600 (60~65535)
6	<input type="checkbox"/>	AUTO	On	3600 (60~65535)
7	<input type="checkbox"/>	AUTO	On	3600 (60~65535)
8	<input type="checkbox"/>	AUTO	On	3600 (60~65535)
9	<input type="checkbox"/>	AUTO	On	3600 (60~65535)
10	<input type="checkbox"/>	AUTO	On	3600 (60~65535)
11	<input type="checkbox"/>	AUTO	On	3600 (60~65535)
12	<input type="checkbox"/>	AUTO	On	3600 (60~65535)

**Apply** **Cancel**

The following table describes the labels in this screen.

**Table 38** Port Authentication: 802.1x

LABEL	DESCRIPTION
RADIUS/Local Profile	Click this link to configure the RADIUS server or local profile settings.
Enable	Select this check box to turn on IEEE 802.1x authentication on the AAM.
Port	This field displays a port number.
Enable	Select this checkbox to turn on IEEE 802.1x authentication on this port.
Control	Select <b>Auto</b> to authenticate all subscribers before they can access the network through this port. Select <b>Force Authorized</b> to allow all connected users to access the network through this port without authentication. Select <b>Force Unauthorized</b> to deny all subscribers access to the network through this port.
Reauthentication	Specify if a subscriber has to periodically re-enter his or her username and password to stay connected to the port.
Reauthentication Period(s)	Specify how often a client has to re-enter his or her username and password to stay connected to the port.
Apply	Click <b>Apply</b> to save your changes to the AAM's volatile memory. The AAM loses these changes if it is turned off or loses power, so use the <b>Config Save</b> link on the navigation panel to save your changes to the non-volatile memory when you are done configuring.
Cancel	Click <b>Cancel</b> to begin configuring this screen afresh.

# CHAPTER 16

## Port Security

This chapter shows you how to set up port security.

### 16.1 About Port Security

Port security allows you to restrict the number of MAC addresses that can be learned on a port. See the product specifications in the appendices for the total number of MAC addresses that the AAM can learn.

### 16.2 Port Security Setup

Click **Advanced Application** and then **Port Security** in the navigation panel to display the **Port Security** screen as shown next.

**Note:** You cannot enable both MAC filtering and port security on a port.

**Figure 68** Port Security

Port	Enable	Limited Number of Learned MAC Address
1	<input type="checkbox"/>	1024 (1-1024)
2	<input type="checkbox"/>	1024 (1-1024)
3	<input type="checkbox"/>	1024 (1-1024)
4	<input type="checkbox"/>	1024 (1-1024)
5	<input type="checkbox"/>	1024 (1-1024)
6	<input type="checkbox"/>	1024 (1-1024)
7	<input type="checkbox"/>	1024 (1-1024)
8	<input type="checkbox"/>	1024 (1-1024)
9	<input type="checkbox"/>	1024 (1-1024)
10	<input type="checkbox"/>	1024 (1-1024)
11	<input type="checkbox"/>	1024 (1-1024)
12	<input type="checkbox"/>	1024 (1-1024)

Apply Cancel Copy port 1 Paste

The following table describes the labels in this screen.

**Table 39** Port Security

LABEL	DESCRIPTION
Port	This field displays a port number.
Enable	Select this check box to restrict the number of MAC addresses that can be learned on the port. Clear this check box to not limit the number of MAC addresses that can be learned on the port.
Limited Number of Learned MAC Address	Specify how many MAC addresses the AAM can learn on this port. The range is 1~1024.
Apply	Click <b>Apply</b> to save your changes to the AAM's volatile memory. The AAM loses these changes if it is turned off or loses power, so use the <b>Config Save</b> link on the navigation panel to save your changes to the non-volatile memory when you are done configuring.
Cancel	Click <b>Cancel</b> to begin configuring this screen afresh.

# CHAPTER 17

## DHCP Relay

This chapter shows you how to set up DHCP relay.

### 17.1 DHCP Relay Overview

DHCP (Dynamic Host Configuration Protocol, RFC 2131 and RFC 2132) allows individual clients to obtain TCP/IP configuration at start-up from a DHCP server. You can configure the AAM to relay client TCP/IP configuration requests to a DHCP server and the server's responses back to the clients.

#### 17.1.1 DHCP Relay Agent Information

The switch can add information to client TCP/IP configuration requests that it relays to a DHCP server. This helps provide authentication about the source of the requests. You can also specify additional information for the switch to add to the client TCP/IP configuration requests that it relays to the DHCP server. Please refer to RFC 3046 for more details.

The DHCP relay agent information feature adds an Agent Information field to the option 82 field of the DHCP headers of client TCP/IP configuration request frames that the switch relays to a DHCP server. The following lists the DHCP relay agent option 82 information that the switch may send to the DHCP server:

- Slot ID (1 byte)
- Port ID (1 byte)
- VLAN ID (2 bytes)
- System name (up to 32 bytes, this is optional).

### 17.2 DHCP Relay Setup

Click **Advanced Application** and then **DHCP Relay** in the navigation panel to display the screen shown next.

**Figure 69** DHCP Relay

The following table describes the labels in this screen.

**Table 40** DHCP Relay

LABEL	DESCRIPTION
Enable DHCP relay	Enable DHCP relay to have the AAM relay client TCP/IP configuration requests to a DHCP server and the server's responses back to the clients.
Remote DHCP server IP	Enter the IP address of the DHCP server to which the AAM should relay DHCP client TCP/IP configuration requests.
Enable Option 82	Select the <b>Enable Option 82</b> check box to have the AAM add information (slot number, port number and VLAN ID) to client TCP/IP configuration requests that it relays to a DHCP server.
Option82	Use this field to specify up to 23 ASCII characters of additional information for the AAM to add to the DHCP client TCP/IP configuration requests that it relays to a DHCP server. Examples of information you could add would be the chassis number or the device identifier of the AAM.
Apply	Click <b>Apply</b> to save your changes to the AAM's volatile memory. The AAM loses these changes if it is turned off or loses power, so use the <b>Config Save</b> link on the navigation panel to save your changes to the non-volatile memory when you are done configuring.
Cancel	Click <b>Cancel</b> to begin configuring this screen afresh.

# CHAPTER 18

## Syslog

This chapter explains how to set the syslog parameters.

### 18.1 Syslog

The syslog feature sends logs to an external syslog server.

### 18.2 Syslog Setup

Click **Advanced Application** and then **SysLog** in the navigation panel to display the screen shown next.

**Figure 70** Syslog

The following table describes the labels in this screen.

**Table 41** Syslog

LABEL	DESCRIPTION
Enable UNIX Syslog	Select this check box to activate syslog (system logging) and then configure the syslog parameters described in the following fields.
SysLog Server IP	Enter the IP address of the syslog server.
Log Facility	Select an option from the drop-down list box. The log facility allows you to log the message to different files in the server. Please refer to the documentation of your syslog program for more details.
Apply	Click <b>Apply</b> to save your changes to the AAM's volatile memory. The AAM loses these changes if it is turned off or loses power, so use the <b>Config Save</b> link on the navigation panel to save your changes to the non-volatile memory when you are done configuring.
Cancel	Click <b>Cancel</b> to begin configuring this screen afresh.



# CHAPTER 19

## Access Control

This chapter describes how to configure access control.

### 19.1 About Access Control

Click **Advanced Application** and then **Access Control** from the navigation panel to display the screen as shown. From this screen you can configure SNMP and enable/disable remote service access.

**Figure 71** Access Control



### 19.2 Access Control Overview

A console port session and a Telnet session cannot coexist. The console port has higher priority. If you telnet to the AAM and someone is already logged in from the console port, then you will see the following message.

**Figure 72** Console Port Priority

```
"Local administrator is configuring this device now!!!
Connection to host lost."
```

A console port or Telnet session can coexist with one FTP session, a web configurator session and/or limitless SNMP access control sessions.

**Table 42** Access Control Overview

CONSOLE PORT	TELNET	FTP	WEB	SNMP
The console port and Telnet share one session. The Console port has the highest priority and Telnet has the lowest priority.		One session	Up to five accounts	No limit

## 19.3 About SNMP

Simple Network Management Protocol is a protocol used for exchanging management information between network switches. SNMP is a member of TCP/IP protocol suite. A manager station can manage and monitor the AAM through the network via SNMP version one (SNMPv1) and/or SNMP version 2c. The next figure illustrates an SNMP management operation. SNMP is only available if TCP/IP is configured.

**Figure 73** SNMP Management Model

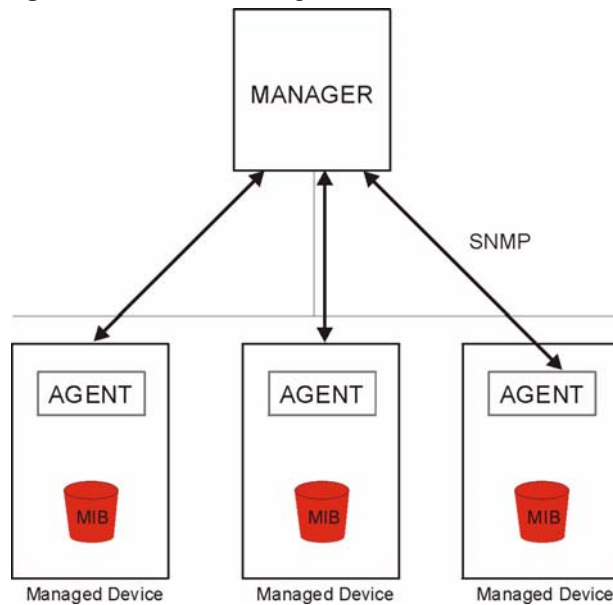

An SNMP managed network consists of two main components: agents and a manager.

An agent is a management software module that resides in a managed switch (the AAM). An agent translates the local management information from the managed switch into a form compatible with SNMP. The manager is the console through which network administrators perform network management functions. It executes applications that control and monitor managed devices.

The managed devices contain object variables/managed objects that define each piece of information to be collected about a switch. Examples of variables include such as number of packets received, node port status etc. A Management Information Base (MIB) is a collection of managed objects. SNMP allows a manager and agents to communicate for the purpose of accessing these objects.

SNMP itself is a simple request/response protocol based on the manager/agent model. The manager issues a request and the agent returns responses using the following protocol operations:

**Table 43** SNMP Commands

COMMAND	DESCRIPTION
Get	Allows the manager to retrieve an object variable from the agent.
GetNext	Allows the manager to retrieve the next object variable from a table or list within an agent. In SNMPv1, when a manager wants to retrieve all elements of a table from an agent, it initiates a Get operation, followed by a series of GetNext operations.
Set	Allows the manager to set values for object variables within an agent.
Trap	Used by the agent to inform the manager of some events.

### 19.3.1 Supported MIBs

MIBs let administrators collect statistics and monitor status and performance. The AAM supports the following MIBs:

- MIB II IF MIB and ADSL line MIB (RFC-2662)
- BRIDGE MIB: dot1dStp (RSTP), dot1dGarp (GARP)
- SNMP MIB II (RFC-1215)

The AAM can also respond with specific data from the ZyXEL private MIBs:

- zyxel.mib
- zyxel-AS-ATM.mib
- zyxel-AESCommon.mib
- zyxel-iesCommon.mib

### 19.3.2 RFC-1215 SNMP Traps

The AAM can send the following SNMP traps (defined in RFC-1215) to an SNMP manager when an event occurs.

**Table 44** RFC-1215 SNMP Traps

TRAP	GENERIC TRAP	SPECIFIC TRAP	DESCRIPTION
sendColdStartTrap	0	0	This trap is sent when the AAM is turned on.
sendWarmStartTrap	1	0	This trap is sent when you restart the AAM using the web configurator or the command line interface. The trap will not be sent when you turn the power off and on.
sendLinkDownTrap	2	0	This trap is sent when the Ethernet link is down.

**Table 44** RFC-1215 SNMP Traps

TRAP	GENERIC TRAP	SPECIFIC TRAP	DESCRIPTION
sendLinkUpTrap	3	0	This trap is sent when the Ethernet or ADSL link is up.
sendAuthFailTrap	4		This trap is sent when an SNMP request comes from non-authenticated hosts.

### 19.3.3 ZyXEL Private MIB SNMP Traps

The AAM can also send the following SNMP traps that are defined in the ZyXEL private MIBs.

**Table 45** ZyXEL Private MIB SNMP Traps

TRAP	DESCRIPTION
sendThermoFailureTrap	This trap is sent when the hardware monitor chip has failed.
sendVoltageOutOfRange Trap	This trap is sent periodically when the AAM's voltage is outside of the accepted operating range.
sendVoltageNormalTrap	This trap is sent when the AAM is no longer outside of the accepted operating range.
sendOverHeatTrap	This trap is sent periodically when the AAM is overheated.
sendOverHeatOverTrap	This trap is sent when the AAM is no longer overheated.
sendRebootTrap	This trap is sent each time the AAM restarts.

### 19.3.4 Configuring SNMP

Click **Advanced Application** and **Access Control** from the navigation panel and then **SNMP** from the **Access Control** screen to open the following screen.

**Figure 74** Access Control: SNMP

The screenshot shows the SNMP configuration interface. It includes the following fields and values:

- Get Community:** public
- Set Community:** public
- Trap Community:** public
- Trap Destination:** 0.0.0.0, Port 162 (1~65535)
- Trusted Host(0.0.0.0 means trust all):** 0.0.0.0

Buttons for **Apply** and **Cancel** are located at the bottom of the form.

The following table describes the labels in this screen.

**Table 46** Access Control: SNMP

LABEL	DESCRIPTION
Return	Click <b>Return</b> to go back to the previous screen.
Get Community	Enter the get community, which is the password for the incoming Get- and GetNext- requests from the management station. You can use up to 31 ASCII characters; spaces are not allowed.
Set Community	Enter the set community, which is the password for incoming Set- requests from the management station. You can use up to 31 ASCII characters; spaces are not allowed.
Trap Community	Enter the trap community, which is the password sent with each trap to the SNMP manager. You can use up to 31 ASCII characters; spaces are not allowed.
Trap Destination	Enter the IP address of a station to send your SNMP traps to.
Port	Enter the port number upon which the station listens for SNMP traps.
Trusted Host	A "trusted host" is a computer that is allowed to use SNMP with the AAM. <b>0.0.0.0</b> allows any computer to use SNMP to access the AAM. Specify an IP address to allow only the computer with that IP address to use SNMP to access the AAM.
Apply	Click <b>Apply</b> to save your changes to the AAM's volatile memory. The AAM loses these changes if it is turned off or loses power, so use the <b>Config Save</b> link on the navigation panel to save your changes to the non-volatile memory when you are done configuring.
Cancel	Click <b>Cancel</b> to begin configuring this screen afresh.

### 19.3.5 Setting Up the Administrator Login Account

Click **Advanced Application** and **Access Control** from the navigation panel and then **Logins** from the **Access Control** screen to open the following screen.

**Note:** It is highly recommended that you change the default administrator password ("1234").

**Figure 75** Access Control: Logins

The screenshot shows a web interface for configuring logins. At the top left, there is a blue header with an orange circle icon and the text 'Logins'. Below this, the word 'Administrator' is displayed in blue. In the top right corner, there is a purple 'Return' link. The main area contains three input fields: 'Old Password', 'New Password', and 'Retype to confirm'. Below these fields are two buttons: 'Apply' and 'Cancel'. At the bottom of the form, there is a red warning message: 'Please record your new password whenever you change it. The system will lock you out if you have forgotten your password.'

The following table describes the labels in this screen.

**Table 47** Access Control: Logins

LABEL	DESCRIPTION
Return	Click <b>Return</b> to go back to the previous screen.
Administrator	This is the default administrator account with the "admin" user name. You cannot change the default administrator user name.
Old Password	Type the existing system password ("1234" is the default password when shipped).
New Password	Enter your new system password.
Retype to confirm	Retype your new system password for confirmation.
Apply	Click <b>Apply</b> to save your changes to the AAM's volatile memory. The AAM loses these changes if it is turned off or loses power, so use the <b>Config Save</b> link on the navigation panel to save your changes to the non-volatile memory when you are done configuring.
Cancel	Click <b>Cancel</b> to begin configuring this screen afresh.

### 19.3.6 Service Access Control Configuration

Click **Advanced Application** and **Access Control** from the navigation panel and then **Service Access Control** from the **Access Control** screen to open the following screen. Use this screen to set which services may be used to access the AAM.

**Figure 76** Access Control: Service Access Control

Services	Active	Server Port
Telnet	<input checked="" type="checkbox"/>	23 (1-65535)
FTP	<input checked="" type="checkbox"/>	21 (1-65535)
WEB	<input checked="" type="checkbox"/>	80 (1-65535)
ICMP	<input checked="" type="checkbox"/>	

Apply Cancel

The following table describes the labels in this screen.

**Table 48** Access Control: Service Access Control

LABEL	DESCRIPTION
Return	Click <b>Return</b> to go back to the previous screen.
Services	Services you may use to access the AAM are listed here.
Active	Select the <b>Active</b> check boxes for the corresponding services that you want to allow to access the AAM.
Server Port	For Telnet, FTP or web services, you may change the default service port by typing the new port number in the <b>Server Port</b> field. If you change the default port number then you will have to let people (who wish to use the service) know the new port number for that service.

**Table 48** Access Control: Service Access Control (continued) (continued)

LABEL	DESCRIPTION
Apply	Click <b>Apply</b> to save your changes to the AAM's volatile memory. The AAM loses these changes if it is turned off or loses power, so use the <b>Config Save</b> link on the navigation panel to save your changes to the non-volatile memory when you are done configuring.
Cancel	Click <b>Cancel</b> to begin configuring this screen afresh.

### 19.3.7 Secured Client Configuration

Click **Advanced Application** and **Access Control** from the navigation panel and then **Secured Client** from the **Access Control** screen to open the following screen. Use this screen to configure IP address ranges of trusted computers that may manage the AAM.

**Figure 77** Access Control: Secured Client Setup

Index	Enable	Start IP Address	End IP Address	Telnet	FTP	Web	ICMP
1	<input checked="" type="checkbox"/>	0.0.0.0	223.255.255.255	<input checked="" type="checkbox"/>	<input checked="" type="checkbox"/>	<input checked="" type="checkbox"/>	<input checked="" type="checkbox"/>
2	<input type="checkbox"/>	0.0.0.0	0.0.0.0	<input type="checkbox"/>	<input type="checkbox"/>	<input type="checkbox"/>	<input type="checkbox"/>
3	<input type="checkbox"/>	0.0.0.0	0.0.0.0	<input type="checkbox"/>	<input type="checkbox"/>	<input type="checkbox"/>	<input type="checkbox"/>
4	<input type="checkbox"/>	0.0.0.0	0.0.0.0	<input type="checkbox"/>	<input type="checkbox"/>	<input type="checkbox"/>	<input type="checkbox"/>

The following table describes the labels in this screen.

**Table 49** Access Control: Secured Client Setup

LABEL	DESCRIPTION
Return	Click <b>Return</b> to go back to the previous screen.
Index	This is the client set index number. A "client set" is a group of one or more "trusted computers" from which an administrator may use a service to manage the AAM.
Enable	Select this check box to activate this secured client set. Clear the check box if you wish to temporarily disable the set without deleting it.
Start IP Address End IP Address	Configure the IP address range of trusted computers from which you can manage the AAM. The AAM checks if the client IP address of a computer requesting a service or protocol matches the range set here. The AAM immediately disconnects the session if it does not match.
Telnet/FTP/Web/ ICMP	Select services that may be used for managing the AAM from the specified trusted computers.
Apply	Click <b>Apply</b> to save your changes to the AAM's volatile memory. The AAM loses these changes if it is turned off or loses power, so use the <b>Config Save</b> link on the navigation panel to save your changes to the non-volatile memory when you are done configuring.
Cancel	Click <b>Cancel</b> to begin configuring this screen afresh.



# CHAPTER 20

## Routing Protocol

This chapter shows you how to configure the static routing function.

### 20.1 Static Route

Static routes tell the AAM how to forward the AAM's own IP traffic when you configure the TCP/IP parameters manually. This is generally useful for allowing management of the switch from a device with an IP address on a different subnet from that of the switch's IP address (remote management).

Click **Routing Protocol** in the navigation panel and then **Static Routing** to display the screen as shown.

**Figure 78** Static Routing

Static Routing

Name

Destination IP Address

IP Subnet Mask

Gateway IP Address

Metric  (1-15)

Page 1 of 1

Index	Name	Destination Address	Subnet Mask	Gateway Address	Metric	Delete
-		Default	-	192.168.1.254	1	-
1		192.168.1.0	255.255.255.0	192.168.1.1	1	<input type="checkbox"/>

The following table describes the related labels you use to create a static route.

**Table 50** Static Routing

LABEL	DESCRIPTION
Name	Type a name to identify this static route. Use up to 31 ASCII characters. Spaces and tabs are not allowed.
Destination IP Address	This parameter specifies the IP network address of the final destination. Routing is always based on network number. If you need to specify a route to a single host, use a subnet mask of 255.255.255.255 in the subnet mask field to force the network number to be identical to the host ID.
IP Subnet Mask	Enter the subnet mask for this destination.

**Table 50** Static Routing (continued)

LABEL	DESCRIPTION
Gateway IP Address	Enter the IP address of the gateway. The gateway is an immediate neighbor of your AAM that will forward the packet to the destination. The gateway must be a router on the same segment as your AAM.
Metric	The metric represents the “cost” of transmission for routing purposes. IP routing uses hop count as the measurement of cost, with a minimum of 1 for directly connected networks. Enter a number that approximates the cost for this link. The number need not be precise, but it must be between 1 and 15. In practice, 2 or 3 is usually a good number.
Add	Click <b>Add</b> to save the new rule to the AAM's volatile memory. It then displays in the summary table at the bottom of the screen. The AAM loses these changes if it is turned off or loses power, so use the <b>Config Save</b> link on the navigation panel to save your changes to the non-volatile memory when you are done configuring.
Cancel	Click <b>Cancel</b> to reset the fields to your previous configuration.

View the current static routes on the AAM in the summary table at the bottom of the screen.

**Figure 79** Static Routing: Summary Table

Index	Name	Destination Address	Subnet Mask	Gateway Address	Metric	Delete
-	-	Default	-	192.168.1.254	1	-
1	-	192.168.1.0	255.255.255.0	192.168.1.1	1	<input type="checkbox"/>

The following table describes the labels in the summary table.

**Table 51** Static Routing: Summary Table

LABEL	DESCRIPTION
Previous Page	Click this to display the preceding page of static route entries.
Next Page	Click this to display the following page of static route entries.
Index	This field displays the index number of the route.
Name	This field displays the name of this static route.
Destination Address	This field displays the IP network address of the final destination.
Subnet Mask	This field displays the subnet mask for this destination.
Gateway Address	This field displays the IP address of the gateway. The gateway is an immediate neighbor of your AAM that will forward the packet to the destination.
Metric	This field displays the cost of transmission for routing purposes.
Delete	Select the rule(s) that you want to remove in the <b>Delete</b> column, and then click the <b>Delete</b> button.
Cancel	Click <b>Cancel</b> to clear the selected checkboxes in the <b>Delete</b> column.

# CHAPTER 21

## Maintenance

This chapter explains how to use the maintenance screens.

### 21.1 Maintenance

Click **Management** and then **Maintenance** in the navigation panel to open the following screen.

**Figure 80** Maintenance



### 21.2 Firmware Upgrade

From the **Maintenance** screen, use **Firmware Upgrade** to upgrade your AAM firmware. See the System Info screen to verify your current firmware version number. Make sure you have downloaded (and unzipped) the correct model firmware and version to your computer before uploading to the device.

**Note:** Be sure to upload the correct model firmware as uploading the wrong model firmware may damage your device.

From the **Maintenance** screen, display the **Firmware Upgrade** screen as shown next.

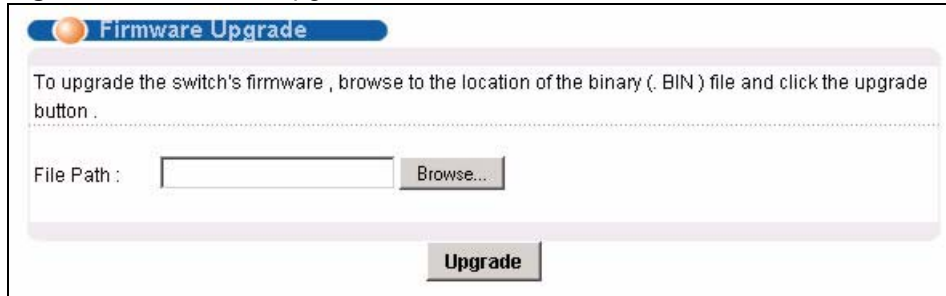
**Figure 81** Firmware Upgrade

Type the path and file name of the firmware file you wish to upload to the AAM in the **File Path** text box or click **Browse** to locate it. After you have specified the file, click **Upgrade**.

After the firmware upgrade process is complete, see the **System Info** screen to verify your current firmware version number.

## 21.3 Restore a Text Configuration File

From the **Maintenance** screen, use **Restore Text Configuration** to open the following screen where you can save a configuration file from your computer to the AAM.

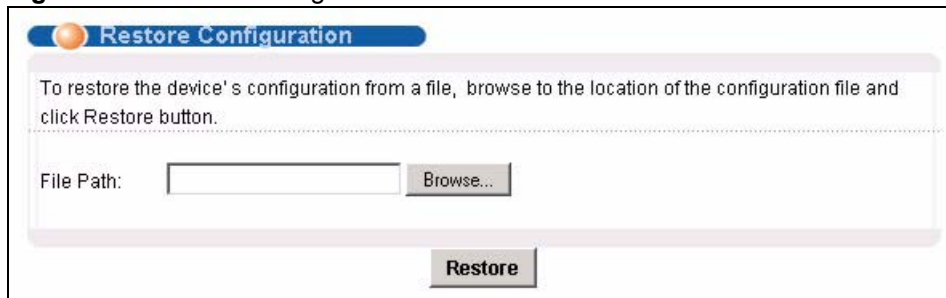
**Figure 82** Restore Configuration

Type the path and file name of the configuration file you wish to restore in the **File Path** text box or click **Browse** to display a **Choose File** screen from which you can locate it. After you have specified the file, click **Restore**. "conf-0" is the name of the configuration file on the AAM, so your backup configuration file is automatically renamed when you restore using this screen.

## 21.4 Backing Up a Configuration File

Backing up your AAM configurations allows you to create various “snap shots” of your device from which you may restore at a later date.

Go to the **Maintenance** screen, and do the following to save your device’s configuration to your computer.

1 Right-click the **Backup Text Configuration Click here** link and click **Save Target As**.

Or:

Click the **Backup Text Configuration Click Here** link and then click **File** and **Save as**.

2 In the **Save As** screen, choose a location to save the file on your computer from the **Save in** drop-down list box and type a descriptive name for it in the **File name** list box. Click **Save** to save the configuration file to your computer.

**Note:** See the chapters on commands to edit the configuration text file.

You can change the “.dat” file to a “.txt” file and still upload it to the AAM.

## 21.5 Load Factory Defaults

From the **Maintenance** screen, use **Restore Default Configuration** to clear all AAM configuration information you configured and return to the factory defaults. Click **OK** in the following screen.

**Figure 83** Confirm Restore Factory Default Settings



Click **OK** to begin resetting all AAM configurations to the factory defaults and then wait for the AAM to restart. This takes up to two minutes. If you want to access the AAM web configurator again, you may need to change the IP address of your computer to be in the same subnet as that of the default AAM IP address (192.168.1.1).

**Figure 84** Restart After Load Factory Defaults

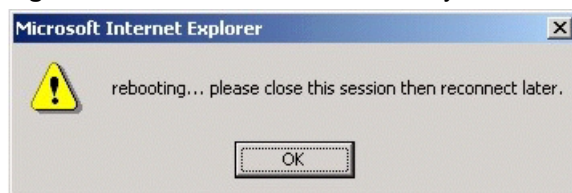

## 21.6 Reboot System

From the **Maintenance** screen, use **Reboot System** to restart the AAM without physically turning the power off. Press the **Click Here** button next to **Reboot System** to display the following screen.

Click **OK**. You then see the screen as shown in [Figure 84 on page 155](#). Click **OK** again and wait for the AAM to restart. This takes up to two minutes. This does not affect the AAM's configuration.

**Figure 85** Confirm Restart



## 21.7 Command Line FTP

See the commands part of this User's Guide for how to upload or download files to or from the AAM using FTP commands.

# CHAPTER 22

## Diagnostic

This chapter explains the **Diagnostic** screen.

### 22.1 Diagnostic

Click **Management** and then **Diagnostic** in the navigation panel to display this screen. Use this screen to check system logs, ping IP addresses or perform loopback tests.

**Figure 86** Diagnostic

The screenshot shows the Diagnostic screen with a log of system events and control buttons. The log contains 20 entries, each with a line number, date, time, source, level, and message. The control buttons are arranged in a grid below the log.

Line	Date	Time	Source	Level	Message
1	Thu Jan 01	06:05:41	1970 Console	INFO	Session End!
2	Thu Jan 01	06:00:01	1970 Console	INFO	Session Begin!
3	Thu Jan 01	02:54:32	1970 Console	INFO	Session End!
4	Thu Jan 01	02:47:47	1970 Console	INFO	Session Begin!
5	Thu Jan 01	00:46:58	1970 Console	INFO	Session End!
6	Thu Jan 01	00:40:10	1970 Console	INFO	Session Begin!
7	Thu Jan 01	00:32:17	1970 Console	INFO	Session End!
8	Thu Jan 01	00:26:41	1970 Console	INFO	Session Begin!
9	Thu Jan 01	00:12:33	1970 Console	INFO	Session End!
10	Thu Jan 01	00:07:11	1970 Console	INFO	Session Begin!
11	Thu Jan 01	00:05:21	1970 Console	INFO	Session End!
12	Thu Jan 01	00:00:30	1970 dslmgr00	INFO	ADSL Link Info: NM:38/18(dB)!
13	Thu Jan 01	00:00:30	1970 dslmgr00	INFO	ADSL 1 Link Up(SN=1): 2045/510!
14	Thu Jan 01	00:00:20	1970 Console	INFO	Session Begin!
15	Thu Jan 01	00:00:20	1970 Console	INFO	Last errorlog repeat 1 Times
16	Thu Jan 01	00:00:10	1970 PINI	INFO	Change time server to none.
17	Thu Jan 01	00:00:06	1970 iw_app	INFO	Ether 2 Link Up(SN=2): 100/100!
18	Thu Jan 01	00:00:05	1970 iw_app	WARN	Ether 2 Link Down(SN=1)!
19	Thu Jan 01	00:00:04	1970 PINI	INFO	System Warm Start!
20	Thu Jan 01	00:00:04	1970 iw_app	INFO	Ether 2 Link Up(SN=1): 100/100!

Control buttons and fields:

- Syslog/ Event Log:
- IP Ping: IP Address    Times(1-10)
- Loopback Test: Port  VPI  VCI
- LDM Test: Port

The following table describes the labels in this screen.

**Table 52** Diagnostic

LABEL	DESCRIPTION
Syslog/ Event Log	Click <b>Display</b> to display a log of events in the multi-line text box. Click <b>Clear</b> to empty the text box and reset the syslog entry.
IP Ping	Type the IP address of a device that you want to ping in order to test a connection. In the field to the right specify the number of times that you want to ping the IP address. Click <b>Ping</b> to have the AAM ping the IP address (in the field to the left).
Loopback Test	Select a port number from the <b>Port</b> drop-down list box and enter a VPI/VCI to specify a PVC. Click <b>OAM F5 Loopback</b> to perform an OAMF5 loopback test on the specified DSL port. An Operational, Administration and Maintenance Function 5 test is used to test the connection between two DSL devices. First, the DSL devices establish a virtual circuit. Then the local device sends an ATM F5 cell to be returned by the remote DSL device (both DSL devices must support ATM F5 in order to use this test). The results ("Passed" or "Failed") display in the multi-line text box.
LDM Test	Select a port number from the <b>Port</b> drop-down list box and click <b>Set LDM Port</b> to have the AAM perform line diagnostics on the specified port. The ADSL port must be set to ADSL2 or ADSL2+ ADSL operational mode and have a connection. It takes about one minute for the line diagnostics to finish. The screen displays a message confirming upon which ADSL port line diagnostics will be performed.  Click <b>Get LDM Data</b> to display the line diagnostics results after using the <b>Set LDM Port</b> button on an ADSL port. Use the line diagnostics results to analyze problems with the physical ADSL line.  <b>Note:</b> Wait at least one minute after using <b>Set LDM Port</b> before using <b>Get LDM Data</b> .

## 22.2 Log Format

The common format of the system logs is: <item no> <time> <process> <type> <log message>

**Table 53** Log Format

LABEL	DESCRIPTION
<item no>	This is the index number of the log entry.
<time>	This is the time and date when the log was created.
<process>	This is the process that created the log.
<type>	This identifies what kind of log it is. "INFO" identifies an information log. "WARN" identifies a warning log.
<log message>	This is the log's detailed information (see <a href="#">Table 54 on page 159</a> ).

## 22.2.1 Log Messages

The following table lists and describes the system log messages.

**Table 54** Log Messages

LOG MESSAGE	TYPE	DESCRIPTION
ADSL <port> Link Up (SN=<seq no>): <ds rate>/<us rate>! or ADSL Link Info: NM:<ds NM>/<us NM>!	INFO	An ADSL port established a connection. <port> - port number <seq no> - sequence number of the connection <ds rate> - downstream rate <us rate> - upstream rate <us NM> - upstream noise margin <ds NM> - downstream noise margin
ADSL <port> Link Down (SN=<seq no>)!	WARN	An ADSL port lost its connection. <port> - port number <seq no> - sequence number of the connection
Session Begin!	INFO	A console, telnet or FTP session has begun (see the <process> field for the type of session).
Session End!	INFO	A console telnet or FTP session has terminated (see the <process> field for the type of session).
Incorrect Password!	WARN	Someone attempted to use the wrong password to start a console, telnet or FTP session (see the <process> field for the type of session).
Received Firmware Checksum Error!	WARN	A checksum error was detected during an attempted FTP firmware upload.
Received Firmware Size too large!	WARN	The file size was too large with an attempted FTP firmware upload.
Received Firmware Invalid!	WARN	Someone attempted to upload a firmware file with a wrong identity via FTP.
Received File <file>!	INFO	A file was uploaded to the AAM by FTP. <file> - received file's name.
THERMO OVER TEMPERATURE: dev:<id> threshold:<threshold> (degree C) value:<temp> (degree C)!	WARN	The temperature was too high at one of the temperature sensors. <id> - 0: sensor near the ADSL chipset - 1: sensor near the CPU - 2: thermal sensor chip itself <threshold> - threshold temperature <temp> - temperature when the entry was logged
THERMO OVER TEMPERATURE released: dev:<id> threshold:<threshold> (degree C) value:<temp> (degree C)!	INFO	The temperature at one of the temperature sensors has come back to normal. <id> - 0: sensor near the ADSL chipset - 1: sensor near the CPU - 2: thermal sensor chip itself <threshold> - threshold temperature <temp> - temperature when the entry was logged

**Table 54** Log Messages

LOG MESSAGE	TYPE	DESCRIPTION
THERMO OVER VOLTAGE: nominal:<nominal> ( mV) value:<voltage> mV) !	WARN	The voltage went outside of the accepted operating range.  <nominal> - nominal voltage of the DC power <voltage> - voltage of the DC power when logged
THERMO OVER VOLTAGE released: nominal:<nominal> ( mV) value:<voltage> (mV) !	INFO	The voltage is back inside the accepted operating range.  <nominal> - nominal voltage of the DC power <voltage> - voltage of the DC power when logged

## 22.3 Line Diagnostics Test Parameters

The following table lists the line diagnostics test parameters that display, see the ITU-T's G.992.3 for more information.

**Table 55** Line Diagnostics Test Parameters

LABEL	DESCRIPTION
number_of_subcarriers	Discrete Multi-Tone (DMT) modulation divides up a line's bandwidth into sub-carriers (sub-channels) of 4.3125 KHz each.  The first number is the total number of DMT sub-carriers the ADSL connection is using. The second number indicates how many upstream DMT sub-carriers the ADSL connection is using.
hlinScale	The channel characteristics function is represented in linear format by a scale factor and a complex number. These are the maximum upstream and downstream scale factors used in producing the channel characteristics function.
latn	This is the upstream and downstream Line Attenuation (in dB).
satn	This is the upstream and downstream Signal Attenuation (in dB).
snrm	This is the upstream and downstream Signal-to-Noise Ratio Margin (in dB). A DMT sub-carrier's SNR is the ratio between the received signal power and the received noise power. The signal-to-noise ratio margin is the maximum that the received noise power could increase with the AAM still being able to meet its transmission targets.
attnr	This is the upstream and downstream Attainable Net Data Rate (in bit/s).
farEndActatp	This is the upstream and downstream Far End Actual Aggregate Transmit Power (in dBm)
i	This is the index number of the DMT sub-carrier.
li.rl	The channel characteristics function is represented in linear format by a scale factor and a complex number. This is the real part of the complex number used in producing the channel characteristics function for this sub-carrier.
li.im	The channel characteristics function is represented in linear format by a scale factor and a complex number. This is the imaginary part of the complex number used in producing the channel characteristics function for this sub-carrier.

**Table 55** Line Diagnostics Test Parameters

LABEL	DESCRIPTION
log	This is a format for providing channel characteristics. It provides magnitude values in a logarithmic scale. This can be used in analyzing the physical condition of the ADSL line.
QLN	The Quiet Line Noise for a DMT sub-carrier is the rms (root mean square) level of the noise present on the line, when no ADSL signals are present. It is measured in dBm/Hz. The QLN can be used in analyzing crosstalk.
SNR	This is the upstream and downstream Signal-to-Noise Ratio (in dB). A DMT sub-carrier's SNR is the ratio between the received signal power and the received noise power. The SNR can be used in analyzing time dependent changes in crosstalk levels and line attenuation (such as those caused by temperature variations and moisture).



# CHAPTER 23

## MAC Table

This chapter introduces the **MAC Table** screen.

### 23.1 Introduction to MAC Table

The MAC table lists device MAC addresses that are dynamically learned by the AAM. The table shows the following for each MAC address: the port upon which Ethernet frames were received from the device, to which VLAN groups the device belongs (if any) and to which channel it is connected (for devices connected to DSL ports).

The switch uses the MAC table to determine how to forward frames. See the following figure.

- 1 The switch examines a received frame and learns the port on which this source MAC address came.
- 2 The switch checks to see if the frame's destination MAC address matches a source MAC address already learned in the MAC table.
  - If the switch has already learned the port for this MAC address, then it forwards the frame to that port.
  - If the switch has not already learned the port for this MAC address, then the frame is flooded to all ports. Too much port flooding leads to network congestion.
  - If the switch has already learned the port for this MAC address, but the destination port is the same as the port it came in on, then it filters the frame.

**Figure 87** MAC Table Filtering Flowchart

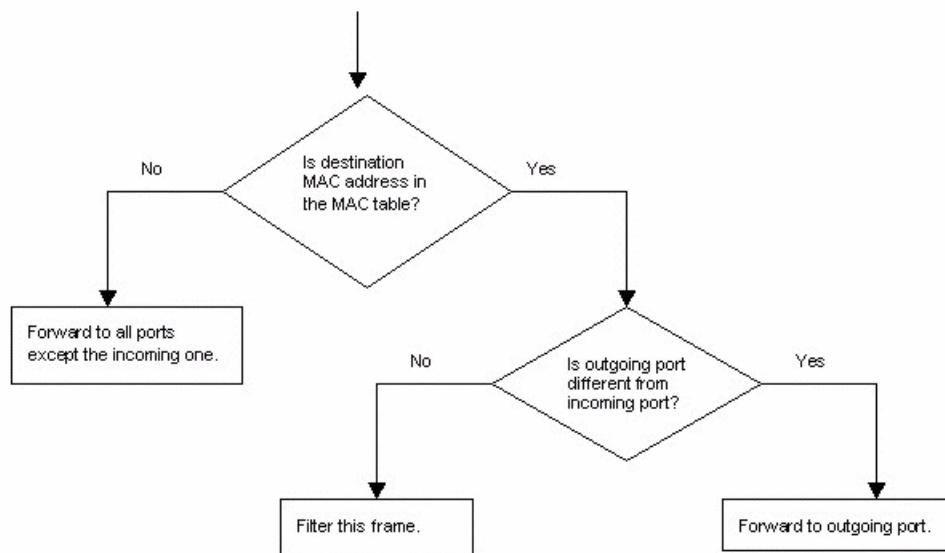

## 23.2 Viewing the MAC Table

Click **Management** in the navigation panel and then **MAC Table** to display the following screen.

**Figure 88** MAC Table



The following table describes the labels in this screen.

**Table 56** MAC Table

LABEL	DESCRIPTION
Get Time	This displays the date and time that the displayed MAC address information was last updated. The date is in year, month and day format. The time is in (24-hour) hour, minute and second format.
Page X of X	This identifies which page of information is displayed and the total number of pages of information.
Previous/Next	Click one of these buttons to show the previous/next screen if all of the information cannot be seen in one screen.
Show	Select an individual port for which to show information.
Index	This is the number of the MAC table entry.
MAC	This is the MAC address of the device that the AAM has learned is connected to the port.
Port	This is the port to which the MAC address is associated.
VID	This is the VLAN group to which the device belongs.
VPI/VCI	This field displays the Virtual Path Identifier and Virtual Circuit Identifier of the channel (PVC) to which the device is connected (for devices connected to DSL ports).
Refresh	Click <b>Refresh</b> to update the list of dynamically learned MAC addresses.
Flush	Click <b>Flush</b> to remove all of the dynamically learned MAC address entries from the MAC table.

# CHAPTER 24

## ARP Table

This chapter introduces the ARP table.

### 24.1 Introduction to ARP Table

Address Resolution Protocol (ARP) is a protocol for mapping an Internet Protocol address (IP address) to a physical machine address, also known as a Media Access Control or MAC address, on the local area network.

An IP (version 4) address is 32 bits long. In an Ethernet LAN, MAC addresses are 48 bits long. The ARP Table maintains an association between each MAC address and its corresponding IP address.

#### 24.1.1 How ARP Works

When an incoming packet destined for a host device on a local area network arrives at the switch, the switch's ARP program looks in the ARP Table and, if it finds the address, sends it to the device.

If no entry is found for the IP address, ARP broadcasts the request to all the devices on the LAN. The switch fills in its own MAC and IP address in the sender address fields, and puts the known IP address of the target in the target IP address field. In addition, the switch puts all ones in the target MAC field (FF.FF.FF.FF.FF.FF is the Ethernet broadcast address). The replying device (which is either the IP address of the device being sought or the router that knows the way) replaces the broadcast address with the target's MAC address, swaps the sender and target pairs, and unicasts the answer directly back to the requesting machine. ARP updates the ARP Table for future reference and then sends the packet to the MAC address that replied.

### 24.2 Viewing the ARP Table

Click **Management** in the navigation panel and then **ARP Table** to open the following screen.

**Figure 89** ARP Table

The screenshot shows a web interface for the ARP Table. At the top, there is a blue header with an orange circle icon and the text 'ARP Table'. Below the header is a 'Flush' button and the text 'Total 7 ARP entries'. Underneath, it says 'Page 1 of 1'. The main content is a table with three columns: 'Index', 'IP Address', and 'MAC Address'. The table contains 7 rows of data. At the bottom of the table, there are two buttons: 'Previous Page' and 'Next Page'.

Index	IP Address	MAC Address
1	172.23.15.100	00:60:f3:20:61:6c
2	172.23.15.107	00:13:49:8d:24:aa
3	172.23.15.170	00:13:49:ba:ec:d1
4	172.23.15.172	02:0e:a6:89:41:60
5	172.23.15.200	00:0d:9d:9b:61:b1
6	172.23.15.219	00:a0:c5:00:00:02
7	172.23.15.254	00:04:80:9b:78:00

The following table describes the labels in this screen.

**Table 57** ARP Table

LABEL	DESCRIPTION
Flush	Click <b>Flush</b> to remove all of the entries from the ARP table.
Total X ARP Entries	This displays the number of entries in the ARP table.
Page X of X	This identifies which page of information is displayed and the total number of pages of information.
Index	This is the ARP table entry number.
IP Address	This is the learned IP address of a device connected to an AAM port.
MAC Address	This is the MAC address of the device with the listed IP address.
Previous/Next Page	Click one of these buttons to show the preceding/following screen if the information cannot be displayed in one screen.

# CHAPTER 25

## Commands Overview

This chapter introduces the command line interface and lists the available commands.

### 25.1 Command Line Interface

**Note:** See the web configurator parts of this User's Guide for background information on features configurable by web configurator.

You can use text command lines for software configuration. The rules of the commands are listed next.

- 1 The command keywords are in `courier new` font.
- 2 A command can be abbreviated to the smallest unique string that differentiates it from other commands. For example the “`sys date`” command could be abbreviated to “`sy d`”.
- 3 The optional fields in a command are enclosed in square brackets [], for instance, `config [save]` means that the `save` field is optional.
- 4 “Command” refers to a command used in the command line interface (CI command).
- 5 The | symbol means “or”.

**Note:** Using commands not documented in the user's guide can damage the unit and possibly render it unusable.

#### 25.1.1 Saving Your Configuration

Use the following command to save your configuration when you are done with a configuration session.

```
ras> config save
```

**Note:** Do not turn off your AAM while saving your configuration.

This command saves all system configurations to nonvolatile memory. You must use this command to save any configuration changes that you make, otherwise the AAM returns to its default settings when it is restarted. Save your changes after each configuration session.

Nonvolatile memory refers to the AAM's storage that remains even if the AAM's power is turned off. Run time (memory) is lost when the AAM's power is turned off.

## 25.2 Commands Summary

The following table lists commands that you can use with the AAM.

**Table 58** Commands

COMMAND				DESCRIPTION
sys				
	info			
		show		Displays general system information.
		hostname	<hostname>	Sets the system name.
		location	<location>	Sets location information.
		contact	<contact>	Sets contact person information.
	passwd			Sets the system's administrator password.
	reboot	[show sec cancel]		Sets the reboot timer or displays the timer and remaining time for reboot. If a reboot has been scheduled, use <code>cancel</code> to prevent a reboot.
	snmp			
		show		Displays SNMP settings.
		getcommunity	<community>	Sets the SNMP GetRequest community.
		setcommunity	<community>	Sets the SNMP SetRequest community.
		trapcommunity	<community>	Sets the SNMP Trap community.
		trustedhost	<ip>	Sets the SNMP trusted host. Set 0.0.0.0 to trust all hosts.
		trapdst	<ip> [<port>]	Sets the SNMP trap server and listening port. Set 0.0.0.0 to not send any SNMP traps.
	server			
		show		Displays the device's service status and port numbers.
		enable	<telnet ftp web icmp>	Turns on a service.
		disable	<telnet ftp web icmp>	Turns off a service.
		port	<telnet ftp web> <port>	Sets a port for a service.
	client			
		show		Displays the device's secured client settings.
		enable	<index>	Allows a secured client set to manage the device.

Table 58 Commands (continued)

COMMAND				DESCRIPTION
		disable	<index>	Stops a secured client set from managing the device.
		set	<index> <start ip> <end ip> [[telnet] [ftp] [web] [icmp]]	Sets a secured client set: a range of IP addresses from which you can manage the device and the protocols that can be used.
	syslog			The syslog feature sends logs to an external syslog server.
		show		Displays the syslog settings.
		enable		Turns on the syslog logging.
		disable		Turns off the syslog logging.
		server	<ip>	Sets the IP address of the syslog server.
		facility	<facility>	Set the log facility (1~7) to log the syslog messages to different files in the syslog server. See your syslog program's documentation for details.
	time			
		show		Displays the system's current time.
		set	<hh> [<mm> [ss]]	Sets the system's time.
	date			
		show		Displays the system's current date.
		set	<yyyy mm dd>	Sets the system's date.
	timeserver			
		show		Displays the system's time server.
		set	<none>	Sets the system to not use a time server.
			<daytime time ntp> <ip> <utc[<+ ->0100~1200]> [nosync]	Sets the time service protocol, time server's IP address and the device's time zone.
		sync		Retrieves the date and time from the time server.
	log			
		show		Displays the device's logs.
		clear		Clears the device's logs.
	wdog			
		show		Displays the current watchdog firmware protection feature status and timer.

**Table 58** Commands (continued)

COMMAND				DESCRIPTION
		set	<msec 0:disable>	Sets the watchdog count. 0 turns the watchdog off.
	monitor			
		show		Displays the hardware monitor's statistics.
		enable		Turns the hardware monitor on.
		disable		Turns the hardware monitor off.
		vlimit	<idx> <high> <low>	Sets the maximum (<high>) or minimum (<low>) voltage at the specified voltage sensor. You can specify a voltage with up to three digits after a decimal point (0.941 for example). Normal voltage at each sensor: Idx: 1=1.0v, 2=1.8v, 3=3.3v, 4=2.4v
		tlimit	<idx> <high> <low>	Sets the maximum (<high>) or minimum (<low>) temperature at the specified temperature sensor. You can specify a temperature with up to three digits after a decimal point (-50.025 for example). Temperature sensor locations: Idx: 1=DSL, 2=CPU, 3=power module
	showall	[nopause]		Displays all system-related configuration.
adsl				
	show	[portlist]		Displays the ADSL settings.
	enable	<portlist>		Turns on the specified ADSL ports.
	disable	<portlist>		Turns off the specified ADSL ports.
	profile			
		show	[profile]	Displays profile contents.

Table 58 Commands (continued)

COMMAND				DESCRIPTION
		set	<profile> <fast  interleave [=<up delay>,<down delay>]> <up max rate> <down max rate> [<up target margin> <up min margin> <up max margin> <up min rate> <down target margin> <down min margin> <down max margin> <down min rate>]	Creates an ADSL profile.
		delete	<profile>	Removes an ADSL profile.
		map	<portlist> <profile> <glite gdm t14 13 auto adsl2 a dsl2+> or <portlist> <profile> <gdm etsi auto  adsl2 adsl2+>	Assigns a specific profile to a port(s) and sets the port's ADSL mode.
	name	<portlist>	<name>	Sets the name of a port(s).
	tel	<portlist> <tel>		Records an ADSL port(s) subscriber's telephone number.
	loopback	<portlist>	<f5> <vpi> <vci>	Performs an OAMF5 loopback test.
	vcprofile			See <a href="#">Section 27.4 on page 212</a> for how to configure virtual channel profiles.
		show	[vcprofile]	Shows a virtual channel profile's contents.
		set	<vcprofile> <vc llc> <ubr cbr> <pcr> <cdvt>	Creates a UBR or CBR virtual channel profile (with encapsulation).
			set <vcprofile> <vc llc> <vbr (rt- vbr)  nrt-vbr> <pcr> <cdvt> <scr> <bt>	Creates a VBR virtual channel profile (with encapsulation).
		delete	<vcprofile>	Removes a virtual channel profile.

**Table 58** Commands (continued)

COMMAND				DESCRIPTION
	pvc			See <a href="#">Section 27.5 on page 214</a> for how to configure Permanent Virtual Circuits.
		show	[<portlist> [<vpi> <vci>]]	Displays PVC settings.
		set	<portlist> <vpi> <vci> <super  vid = 1..4094 <priority>> <vcprofile>	Creates or modifies a PVC setting.
		delete	<portlist> <vpi> <vci>	Removes a PVC setting.
	showall	[nopause]		Displays all ADSL configuration.
	linediag			
		setld	<port number>	Sets the specified port to line diagnostic mode.
		getld	<port number>	Displays the specified port line diagnostics.
	alarmprofile			See <a href="#">Section 27.3.13 on page 208</a> for how to configure alarm profiles.
		show	[profile]	Displays alarm profiles and their settings.

Table 58 Commands (continued)

COMMAND				DESCRIPTION
		set	<profile> [<atuc lofs> <atur lofs> <atuc loss> <atur loss> <atuc lols> <atur lols> <atuc lprs> <atur lprs> <atuc ess> <atur ess> <atuc fast rateup> <atur fast rateup> <atuc interleave rateup> <atur interleave rateup> <atuc fast ratedown> <atur fast ratedown> <atuc interleave ratedown> <atur interleave ratedown> <init fail enable> <atuc ses> <atur ses> <atuc uas> <atur uas>]	Configures an alarm profile.
		delete	<profile>	Removes an alarm profile.
		map	<portlist> <profile>	Maps specified ADSL ports to an alarm profile.
		showmap	[port number]	Displays alarm profile to ADSL port mapping.
		showport	[port]	Displays which alarm profile parameters are mapped to an ADSL port.
	annexl			This only applies to the AAM1212-51.
		enable	<portlist>	Turns on the Annex L feature on the specified port(s).
		disable	<portlist>	Turns off the Annex L feature on the specified port(s).
		show	<portlist>	Displays the Annex L feature setting for the specified port(s).
	sra			
		enable	<portlist>	Turns on Seamless Rate Adaptation (SRA) ADSL2+ on the specified port(s).

**Table 58** Commands (continued)

COMMAND				DESCRIPTION
		disable	<portlist>	Turns off SRA ADSL2+ on the specified port(s).
		show	<portlist>	Displays the SRA ADSL2+ setting for the specified port(s).
	pmm			
		enable	<portlist>	Turns on the Power Management feature on the specified port(s).
		disable	<portlist>	Turns off the Power Management feature on the specified port(s).
		show	<portlist>	Displays the Power Management feature setting for the specified port(s).
switch				
	igmpsnoop			
		show		Displays the IGMP snooping setting.
		enable		Turns on IGMP snooping.
		disable		Turns off IGMP snooping.
	igmpfilter			
		set	[<port> *] <name>	Sets an ADSL port(s) to use an IGMP filter profile.
		show	[portlist]	Displays which IGMP filter profile an ADSL port(s) is using.
		profile		
			set <name> <index> <startip> <endip>	Configures an IGMP filter profile.
			delete <name>	Removes an IGMP filter profile.
			show [name]	Displays an IGMP filter profile's settings.
	queuemap			
		show		Displays the system's priority level to physical queue mapping.
		set	<priority> <queue>	Maps a priority level to a physical queue.
	garptimer			
		show		Displays the GARP timer status.
		join	<join msec>	Sets the GARP timer's Join Timer.
		leave	<leave msec>	Sets the GARP timer's Leave Timer.
		leaveall	<leaveall msec>	Sets the GARP timer's Leave All Timer.
	rstp			Rapid STP commands (refer to IEEE 802.1w).

**Table 58** Commands (continued)

COMMAND				DESCRIPTION
		show		Displays the RSTP settings.
		enable		Turns on RSTP.
		disable		Turns off RSTP.
		priority	<priority>	Sets the system's priority.
		hellotime	<hellotime sec>	Sets the hello timer.
		maxage	<maxage sec>	Sets the max age timer.
		fwdelay	<fwdelay sec>	Sets the forward delay time.
		port	show	Displays the Ethernet ports' RSTP settings.
			enable <enet1 enet2 *>	Enables RSTP on a port.
			disable <portlist>	Disables RSTP on a port.
			priority <portlist> <priority>	Sets the specified port's priority.
			pathcost <portlist> <pathcost>	Sets the specified port's path cost.
	dhcprelay			
		show		Displays DHCP relay settings.
		enable		Turns on DHCP relay.
		disable		Turns off DHCP relay.
		server	<server ip>	Sets a DHCP relay server IP address entry.
		option82		
			enable	Turns on the DHCP relay agent information (Option 82) feature.
			disable	Turns off the DHCP relay agent information (Option 82) feature.
			set <relay info>	Adds the specified information for the relay agent.
	vlan			See <a href="#">Section 28.8 on page 228</a> for how to configure Virtual LAN.
		show	<vlanlist>	Displays VLAN settings.
		portshow	[portlist]	Displays the port(s) VLAN settings.
		set	<vid><portlist> :<F<T U> X N> [<portlist>: <F<T U> X N> ...] [name]	Configures a VLAN entry.
		enable	<vid>	Turns on a VLAN entry.

**Table 58** Commands (continued)

COMMAND				DESCRIPTION
		disable	<vid>	Turns off a VLAN entry.
		delete	<vlanlist>	Removes a VLAN entry.
		pvid	<portlist> <pvid>	Sets the PVID (Port VLAN ID) assigned to untagged frames or priority frames (0 VID) received on this port(s).
		priority	<portlist> <priority>	Sets a port's default IEEE 802.1p priority.
		gvrp	<portlist> <enable disable>	Turns GVRP on or off for the specified ports.
		frametype	<portlist> <all tag untag>	Sets the specified DSL port to accept VLAN tagged or untagged Ethernet frames (or both).
		cpu	show	Displays the VLAN ID of the management VLAN.
			set <vid>	Sets the VLAN ID of the management VLAN.
	mac			
		flush		Clears learned MAC addresses from the forwarding table.
		agingtime		
			show	Displays the MAC aging out time period.
			set <sec 0:disabled>	Sets the MAC aging out time period.
		count		
			show [portlist]	Displays the system's current MAC address count settings.
			enable <portlist>	Turns on the MAC address count filter for a port(s).
			disable <portlist>	Turns off the MAC address count filter for a port(s).
			set <portlist> <count>	Sets the MAC address count filter for a port(s).
		filter	show [portlist]	Displays MAC filter settings.
			enable <portlist>	Turns on the MAC filter for a port(s).
			disable <portlist>	Turns off the MAC filter for a port(s).
			set <port> <mac> [<mac> <mac> ...]	Adds a MAC filter MAC entry.

**Table 58** Commands (continued)

COMMAND				DESCRIPTION
			delete <port> <mac> [<mac> <mac> ...]	Removes a MAC filter MAC entry.
	pktfilter			See <a href="#">Section 28.13 on page 242</a> for how to configure packet filters.
		show	[portlist]	Displays packet type filter settings.
		set	<portlist> [pppoe ip arp netbios dhcp eapol igmp none]	Sets the packet type filter for a specific port. none accepts all packets. This command disables the pktfilter pppoeonly <portlist> command.
		pppoeonly	<portlist>	Uses this command to allow only PPPoE traffic. It drops any non-PPPoE packets. This command disables the pktfilter set <portlist> [pppoe ip arp netbios dhcp eapol igmp none] command.
	dot1x			
		show	[portlist]	Displays IEEE 802.1X settings.
		enable		Turns on IEEE 802.1X.
		disable		Turns off IEEE 802.1X.
		auth	<profile radius>	Sets IEEE 802.1X to use the local profiles or an external RADIUS server for authentication.
		port		
			enable <portlist>	Turns on IEEE 802.1X for specific ports.
			disable <portlist>	Turns off IEEE 802.1X for specific ports.
			control <portlist> <auto auth unauth>	Sets the IEEE 802.1X port authentication option for specific ports.
			reauth <portlist> <on off>	Sets the IEEE 802.1X re-authentication option for specific ports.
			period <portlist> <period>	Sets the IEEE 802.1X re-authentication period for specific ports.
		radius		
			show	Displays the external RADIUS server settings.
			ip <ip>	Sets the external RADIUS server IP address.

**Table 58** Commands (continued)

COMMAND				DESCRIPTION
			port <port>	Sets the external RADIUS server port number.
			secret <secret>	Sets the authentication and encryption key.
		profile		
			show	Displays the local profiles.
			set <name> <password>	Creates or edits a local profile.
			delete <name>	Removes a local profile.
	enet			
		show		Displays the Ethernet port settings.
		speed	<portlist> <10copper 100copper auto>	Sets the Ethernet port(s) connection speed.
		name	<portlist> <name>	Sets the Ethernet port(s) name.
		enable	<portlist>	Turns on the specified Ethernet port(s).
		disable	<portlist>	Turns off the specified Ethernet port(s).
	smcast			Use the static multicast filter to pass routing protocols, such as RIP and OSPF.
		show		Display all MAC addresses joined to ADSL ports.
		set	<adsl_port> <mac> <join leave>	Use join/leave to add/ remove multicast MAC addresses (up to ten) on specified ADSL ports, a range of ADSL ports or all ADSL ports. MAC example: 01005E010203
		delete	<mac>	Removes a static multicast filter entry by deleting the associated MAC address.
	isolation			
		show		Displays the subscriber isolation feature's current setting.
		enable		Turns the subscriber isolation feature on.
		disable		Turns the subscriber isolation feature off.
		daisychain		Sets the device to daisychain mode.
		standalone		Sets the device to standalone mode.
	showall	[nopause]		Displays all of the AAM's switch configuration.
ip				

**Table 58** Commands (continued)

COMMAND				DESCRIPTION
	show			Displays the management IP address settings.
	arp			
		show		Displays the device's IP Address Resolution Protocol status.
		flush		Clears the device's IP Address Resolution Protocol status.
	set	<ip> [/netmask]		Sets the management IP address and subnet mask.
	gateway	<gateway ip>		Sets the IP address of the device's default gateway.
	route			
		show		Displays the routing table.
		set	<dst ip> [/netmask] <gateway ip> [metric] <name>	Adds a routing table entry.
			default <gateway ip> <metric>	Sets the AAM's default route.
		delete	<dst ip> [/netmask]	Removes a routing table entry.
		flush		Clears the routing table.
	ping	<ip> [count]		Pings a remote host.
	showall	[nopause]		Displays all of the AAM's IP configuration.
statistics				
	monitor			Displays hardware monitor statistics.
	adsl			
		show	[portlist]	Displays ADSL port connection statistics.
		linedata	<portlist>	Displays the line data load per symbol (tone).
		lineinfo	<portlist>	Displays the statistics of the specified ADSL ports.
		lineperf	<portlist>	Displays the line quality of the specified ADSL port.
		linerate	<portlist>	Displays the line rate.
		15mperf	<portlist> [count <0..96>]	Displays line performance statistics for the current and previous 15-minute periods.
		1dayperf	<portlist>	Displays line performance statistics for the current and previous 24 hours.

**Table 58** Commands (continued)

COMMAND			DESCRIPTION
	igmpsnoop		Displays IGMP snooping statistics.
	rstp		Displays RSTP statistics.
	vlan	[vlanlist]	Displays current VLANs.
	mac		Displays the current MAC address forwarding table.
	port	<portlist> [<vpi> <vci>] [clear]	This command displays and/or erases port statistics.
	dot1x	[portlist]	Displays IEEE 802.1x statistics.
	enet		Displays Ethernet port settings and statistics.
	ip		Displays a management port's status and performance data.
	showall	[nopause]	Displays all statistics configuration.
config			
	show	<sys sw adsl  ip stat all> [nopause]	Displays the device's configuration.
	save		Saves the current configuration.
	restore		Reloads the factory default configuration.
exit			Ends the console or telnet session.

# CHAPTER 26

## Sys Commands

This chapter describes the commonly used commands that belong to the sys (system) group of commands.

### 26.1 Sys Commands Summary

The following table lists the `sys` commands you can use with the AAM.

**Table 59** Sys Commands

COMMAND				DESCRIPTION
<code>sys</code>				
	<code>info</code>			
		<code>show</code>		Displays general system information.
		<code>hostname</code>	<code>&lt;hostname&gt;</code>	Sets the system name.
		<code>location</code>	<code>&lt;location&gt;</code>	Sets location information.
		<code>contact</code>	<code>&lt;contact&gt;</code>	Sets contact person information.
	<code>passwd</code>			Sets the system's administrator password.
	<code>reboot</code>	<code>[show sec cancel]</code>		Sets the reboot timer or displays the timer and remaining time for reboot. If a reboot has been scheduled, use <code>cancel</code> to prevent a reboot.
	<code>snmp</code>			
		<code>show</code>		Displays SNMP settings.
		<code>getcommunity</code>	<code>&lt;community&gt;</code>	Sets the SNMP GetRequest community.
		<code>setcommunity</code>	<code>&lt;community&gt;</code>	Sets the SNMP SetRequest community.
		<code>trapcommunity</code>	<code>&lt;community&gt;</code>	Sets the SNMP Trap community.
		<code>trustedhost</code>	<code>&lt;ip&gt;</code>	Sets the SNMP trusted host. Set 0.0.0.0 to trust all hosts.
		<code>trapdst</code>	<code>&lt;ip&gt; [&lt;port&gt;]</code>	Sets the SNMP trap server and listening port. Set 0.0.0.0 to not send any SNMP traps.
	<code>server</code>			
		<code>show</code>		Displays the device's service status and port numbers.

**Table 59** Sys Commands (continued)

COMMAND				DESCRIPTION
		enable	<telnet ftp web icmp>	Turns on a service.
		disable	<telnet ftp web icmp>	Turns off a service.
		port	<telnet ftp web> <port>	Sets a port for a service.
	client			
		show		Displays the device's secured client settings.
		enable	<index>	Allows a secured client set to manage the device.
		disable	<index>	Stops a secured client set from managing the device.
		set	<index> <start ip> <end ip> [[telnet] [ftp] [web] [icmp]]	Sets a secured client set: a range of IP addresses from which you can manage the device and the protocols that can be used.
	syslog			The syslog feature sends logs to an external syslog server.
		show		Displays the syslog settings.
		enable		Turns on the syslog logging.
		disable		Turns off the syslog logging.
		server	<ip>	Sets the IP address of the syslog server.
		facility	<facility>	Set the log facility (1~7) to log the syslog messages to different files in the syslog server. See your syslog program's documentation for details.
	time			
		show		Displays the system's current time.
		set	<hh> [<mm> [ss]]	Sets the system's time.
	date			
		show		Displays the system's current date.
		set	<yyyy mm dd>	Sets the system's date.
	timeserver			
		show		Displays the system's time server.
		set	<none>	Sets the system to not use a time server.
			<daytime time ntp> <ip> <utc[<+ ->0100~1200]> [nosync]	Sets the time service protocol, time server's IP address and the device's time zone.

**Table 59** Sys Commands (continued)

COMMAND				DESCRIPTION
		sync		Retrieves the date and time from the time server.
	log			
		show		Displays the device's logs.
		clear		Clears the device's logs.
	wdog			
		show		Displays the current watchdog firmware protection feature status and timer.
		set	<msec 0:disable>	Sets the watchdog count. 0 turns the watchdog off.
	monitor			
		show		Displays the hardware monitor's statistics.
		enable		Turns the hardware monitor on.
		disable		Turns the hardware monitor off.
		vlimit	<idx> <high> <low>	Sets the maximum (<high>) or minimum (<low>) voltage at the specified voltage sensor. You can specify a voltage with up to three digits after a decimal point (0.941 for example). Normal voltage at each sensor: Idx: 1=1.0v, 2=1.8v, 3=3.3v, 4=2.4v
		tlimit	<idx> <high> <low>	Sets the maximum (<high>) or minimum (<low>) temperature at the specified temperature sensor. You can specify a temperature with up to three digits after a decimal point (-50.025 for example). Temperature sensor locations: Idx: 1=DSL Line Driver, 2=DSL Chipset, 3=CPU
	showall	[nopause]		Displays all system-related configuration.

## 26.2 Sys Command Examples

These are the commonly used commands that belong to the sys (system) group of commands.

### 26.2.1 Info Show Command

Syntax:

```
ras> sys info show
```

This command shows general system settings, such as the RAS code, firmware version, system uptime and bootbase version.

An example is shown next.

**Figure 90** Info Show Command Example

```
ras> sys info show
      Hostname:
      Location:
      Contact:
      Model: AAM1212-51
      ZyNOS version: V350 (ABA.0)b2 | 04/18/2005
      MAC address: 00:13:49:24:52:34
      ZyNOS size: 2203086
      System up time:  0(days) :    0:12:13
      Bootbase version: V1.03 (AAM1212-51) | 02/18/2005
      ZyNOS build date: Apr 27 2005 20:30:15
      DSP f/w version:  6.02.0005
      Hardware version:
      Serial number:
```

## 26.2.2 Password Command

Syntax:

```
ras> sys passwd
```

This command allows you to change the system's password.

An example is shown next.

**Figure 91** Passwd Command Example

```
ras> sys passwd
type old password:
type new password (max: 31 chars):
retype new password:
password changed ok
ras>
```

## 26.2.3 SNMP Overview

SNMP (Simple Network Management Protocol) is a protocol used for exchanging management information between network devices. The AAM supports SNMP versions one and two (SNMPv1 and SNMPv2) agent functionality, which allows a manager station to manage and monitor it through the network. See the web configurator chapter on SNMP for background information on SNMP and the AAM's supported MIBs and SNMP traps.

## 26.2.4 SNMP Commands

Use the following commands to configure SNMP for the AAM.

### 26.2.4.1 Get Community Command

Syntax:

```
sys snmp getcommunity <community>
```

where

<community> = The password for the incoming Get- and GetNext- requests from the management station.

Enter this command with the community to set the password.

### 26.2.4.2 Set Community Command

Syntax:

```
sys snmp setcommunity <community>
```

where

<community> = The password for the incoming Set- requests from the management station.

Enter this command with the community to set the password.

### 26.2.4.3 Trusted Host Set Command

Syntax:

```
sys snmp trusthost set <ip>
```

where

<ip> = The IP address of a trusted host.

Use this command to add the host IP address to the list of trusted hosts. If you enter a trusted host, your AAM will only respond to SNMP messages from this address. If you leave the trusted host set to 0.0.0.0 (default), the AAM will respond to all SNMP messages it receives, regardless of source.

#### 26.2.4.4 Trap Community Command

Syntax:

```
sys snmp trapcommunity <community>
```

where

<community> = The password sent with each trap to the SNMP manager.

Enter this command with the community to set the password.

#### 26.2.4.5 Trap Destination Set Command

Syntax:

```
sys snmp trapdst set <ip> [<port>]
```

where

<ip> = The IP address of the trap server.

[<port>] = The port number upon which the trap server listens for SNMP traps.

The AAM uses the default of 162 if you do not specify a trap port

Use this command specify the IP address (and port number) of the trap server to which the AAM sends SNMP traps. If you leave the trap destination set to 0.0.0.0 (default), the AAM will not send any SNMP traps.

#### 26.2.4.6 Show SNMP Settings Command

Syntax:

```
sys snmp show
```

This command displays the current SNMP get community, set community, trap community, trusted hosts and trap destination settings.

#### 26.2.5 Server Show Command

Syntax:

```
ras> sys server show
```

This command displays which services may be used to access the AAM.

An example is shown next.

**Figure 92** Server Show Command Example

```

ras> sys server show
server status  port
-----
telnet   V    23
ftp      V    21
web      V    80
icmp     V

```

## 26.2.6 Server Port Command

Syntax:

```
ras> sys server port <telnet|ftp|web> <port>
```

This command changes the port for a service on the AAM.

The following example sets the AAM to use port 24 for Telnet sessions.

**Figure 93** Server Port Command Example

```

ras> sys server port telnet 24

```

## 26.2.7 Client Show Command

Syntax:

```
ras> sys client show
```

This command displays the secured client settings. These are the IP addresses of trusted computers that can manage the AAM and the services that they can use.

An example is shown next. A “V” in a column means that the secured client set is activated or the services can be used for managing the AAM.

**Figure 94** Client Show Command Example

```

ras> sys client show
Index Status      Start IP          End IP  ICMP  TELNET  FTP  WEB
-----
  1     V           0.0.0.0 223.255.255.255  V     V     V   V
  2     -           0.0.0.0 0.0.0.0         -     -     -   -
  3     -           0.0.0.0 0.0.0.0         -     -     -   -
  4     -           0.0.0.0 0.0.0.0         -     -     -   -

```

## 26.2.8 Client Set Command

Syntax:

```
ras> sys client set <index> <start ip> <end ip> [[telnet] [ftp] [web]
[icmp]]
```

This command configures IP address ranges of trusted computers that may manage the AAM and the services that they can use.

An example is shown next.

**Figure 95** Client Set Command Example

```
ras> sys client set 1 192.168.1.7 192.168.1.35 ftp
```

## 26.2.9 Syslog Show Command

Syntax:

```
sys syslog show
```

This command displays the syslog settings.

An example is shown next.

**Figure 96** Syslog Show Command Example

```
ras> sys syslog show
status    : disabled
server ip: 0.0.0.0
facility  : Local1
```

## 26.2.10 Syslog Server Command

Syntax:

```
sys syslog server <ip>
```

This command sets the IP address of the syslog server.

An example is shown next.

**Figure 97** Syslog Server Command Example

```
ras> sys syslog server 172.23.15.1
```

## 26.2.11 Syslog Enable Command

Syntax:

```
sys syslog enable
```

This command sets the AAM to send logs to an external syslog server.

An example is shown next.

**Figure 98** Syslog Enable Command Example

```
ras> sys syslog enable
```

## 26.2.12 Time Show Command

Syntax:

```
sys time show
```

This command displays the system's current time.

An example is shown next.

**Figure 99** Time Show Command Example

```
ras> sys time show  
current time is 00:09:42
```

## 26.2.13 Time Set Command

Syntax:

```
sys time set <hh> [<mm> [ss]]
```

This command sets the system's time.

An example is shown next.

**Figure 100** Time Set Command Example

```
ras> sys time set 17:34:20
```

## 26.2.14 Date Show Command

Syntax:

```
sys date show
```

This command displays the system's current date.

An example is shown next.

**Figure 101** Date Show Command Example

```
ras> sys date show
current date is Thu 1970/01/01
```

## 26.2.15 Date Set Command

Syntax:

```
sys date set <yyyy> <mm> <dd>
```

This command sets the system's date.

An example is shown next.

**Figure 102** Date Set Command Example

```
ras> sys date set 2005 04 28
```

## 26.2.16 Time Server Show Command

Syntax:

```
sys timeserver show
```

This command displays the system's time server settings.

An example is shown next.

**Figure 103** Time Server Show Command Example

```
ras> sys timeserver show
mode      : none
server    : 0.0.0.0
timezone: utc
```

## 26.2.17 Time Server Set Command

Syntax:

```
sys timeserver set <none>
sys timeserver set <daytime|time|ntp> <ip> <utc[<+|->0100~1200]> [nosync]
```

where

[none]	=	This sets the system to not use a time server.
<daytime time ntp>	=	The time service protocol.
>		
		<daytime> When you select the Daytime (RFC 867) format, the switch displays the day, month, year and time with no time zone adjustment. When you use this format it is recommended that you use a Daytime timeserver within your geographical time zone.
		<time> Time (RFC-868) format displays a 4-byte integer giving the total number of seconds since 1970/1/1 at 0:0:0.
		<ntp> NTP (RFC-1305) is similar to Time (RFC-868).
<ip>	=	The IP address of the time server.
<utc[<+ ->0100~1200]>	=	The time difference between UTC (Universal Time Coordinated, formerly known as GMT, Greenwich Mean Time) and your time zone.
[nosync]	=	This sets the system to not synchronize with the time server immediately after you press [Enter].

This command sets the AAM to use a time server.

The following example sets the AAM to use Daytime protocol to access a time server at IP address 192.50.77.164 and sets the AAM's time zone to UTC.

**Figure 104** Time Server Set Command Example

```
ras> sys timeserver set daytime 192.50.77.164 utc
```

## 26.2.18 Log Show Command

Syntax:

```
ras> sys log show
```

This command displays the system error log.

An example is shown next.

**Figure 105** Log Show Command Example

```
ras> sys log show
  1 Wed Aug 11 20:37:11 2004 telnetd  INFO  Session Begin!
  2 Wed Aug 11 20:37:05 2004 telnetd  INFO  Session Begin!
  3 Wed Aug 11 20:36:56 2004 telnetd  INFO  Session Begin!
```

## 26.2.19 Log Clear Command

Syntax:

```
ras> sys log clear
```

This command clears the system error log.

**Note:** If you clear a log (using the `log clear` command), you cannot view it again.

## 26.2.20 Monitor Show Command

Syntax:

```
ras> sys monitor show
```

This command displays the hardware monitor's statistics.

An example is shown next.

**Figure 106** Monitor Show Command Example

```
ras> sys monitor show
Hardware monitor status: enabled
          limit(hi) limit(lo)
-----
v1(v)    1.344      1.056
v2(v)    1.944      1.656
v3(v)    3.564      3.036
v4(v)   19.440     16.560
t1(c)    97.0       -55.0
t2(c)    97.0       -55.0
t3(c)    97.0       -55.0
```

## 26.2.21 Monitor Vlimit Command

Syntax:

```
ras> sys monitor vlimit <idx> <high> <low>
```

where

<idx> = The index number of the sensor that can detect and report the voltage.

<high> = The maximum voltage limit at a sensor.

You can specify a voltage with up to three digits after a decimal point (0.941 for example).

<low> = The minimum voltage limit at a sensor.

You can specify a voltage with up to three digits after a decimal point (0.941 for example).

This command sets the maximum and minimum voltage at a voltage sensor.

The following example sets the highest (1.242) and the lowest (1.035) voltage limit at the first sensor.

**Figure 107** Monitor Vlimit Command Example

```
ras> sys monitor vlimit 1 1.242 1.035
```

## 26.2.22 Monitor Tlimit Command

Syntax:

```
ras> sys monitor tlimit <idx> <high> <low>
```

where

<idx> = The index number of the temperature sensor that can detect and report the temperature.

<high> = The maximum temperature limit at a sensor.

You can specify a temperature with up to three digits after a decimal point (-50.025 for example).

<low> = The minimum voltage limit at a sensor.

You can specify a temperature with up to three digits after a decimal point (-50.025 for example).

The following example sets the highest (97.0) and the lowest (-55.0) temperature limit at the first sensor.

**Figure 108** Monitor Tlimit Command Example

```
ras> sys monitor tlimit 1 97.0 -55.0
```

# CHAPTER 27

## ADSL Commands

This chapter describes some of the ADSL commands that allow you to configure and monitor the ADSL ports.

### 27.1 ADSL Standards Overview

See the web configurator chapter on ADSL for background information. Refer to [Section 5.3 on page 60](#) for the settings of the default profile and ADSL port default settings.

### 27.2 ADSL Commands Summary

The following table lists the `adsl` commands you can use with the AAM.

**Table 60** ADSL Commands

COMMAND				DESCRIPTION
<code>adsl</code>				
	<code>show</code>	<code>[portlist]</code>		Displays the ADSL settings.
	<code>enable</code>	<code>&lt;portlist&gt;</code>		Turns on the specified ADSL ports.
	<code>disable</code>	<code>&lt;portlist&gt;</code>		Turns off the specified ADSL ports.
	<code>profile</code>			
		<code>show</code>	<code>[profile]</code>	Displays profile contents.
		<code>set</code>	<code>&lt;profile&gt; &lt;fast  interleave [=&lt;up delay&gt;,&lt;down delay&gt;]&gt; &lt;up max rate&gt; &lt;down max rate&gt; [&lt;up target margin&gt; &lt;up min margin&gt; &lt;up max margin&gt; &lt;up min rate&gt; &lt;down target margin&gt; &lt;down min margin&gt; &lt;down max margin&gt; &lt;down min rate&gt;]</code>	Creates an ADSL profile.

**Table 60** ADSL Commands (continued)

COMMAND				DESCRIPTION
		delete	<profile>	Removes an ADSL profile.
		map	<portlist> <profile> <glite gdm t14 13 auto adsl2 a dsl2+> or <portlist> <profile> <gdm etsi auto  adsl2 adsl2+>	Assigns a specific profile to a port(s) and sets the port's ADSL mode.
	name	<portlist>	<name>	Sets the name of a port(s).
	tel	<portlist> <tel>		Records an ADSL port(s) subscriber's telephone number.
	loopback	<portlist>	<f5> <vpi> <vci>	Performs an OAMF5 loopback test.
	vcprofile			See <a href="#">Section 27.4 on page 212</a> for how to configure virtual channel profiles.
		show	[vcprofile]	Shows a virtual channel profile's contents.
		set	<vcprofile> <vc llc> <ubr cbr> <pcr> <cdvt>	Creates a UBR or CBR virtual channel profile (with encapsulation).
			set <vcprofile> <vc llc> <vbr (rt- vbr)  nrt-vbr> <pcr> <cdvt> <scr> <bt>	Creates a VBR virtual channel profile (with encapsulation).
		delete	<vcprofile>	Removes a virtual channel profile.
	pvc			See <a href="#">Section 27.5 on page 214</a> for how to configure Permanent Virtual Circuits.
		show	[<portlist> [<vpi> <vci>]]	Displays PVC settings.
		set	<portlist> <vpi> <vci> <super  vid = 1..4094 <priority>> <vcprofile>	Creates or modifies a PVC setting.
		delete	<portlist> <vpi> <vci>	Removes a PVC setting.
	showall	[nopause]		Displays all ADSL configuration.
	linediag			

**Table 60** ADSL Commands (continued)

COMMAND				DESCRIPTION
		setld	<port number>	Sets the specified port to line diagnostic mode.
		getld	<port number>	Displays the specified port line diagnostics.
	alarmprofile			See <a href="#">Section 27.3.13 on page 208</a> for how to configure alarm profiles.
		show	[profile]	Displays alarm profiles and their settings.
		set	<profile> [<atuc lofs> <atur lofs> <atuc loss> <atur loss> <atuc lols> <atur lprs> <atur lprs> <atuc ess> <atur ess> <atuc fast rateup> <atur fast rateup> <atuc interleave rateup> <atur interleave rateup> <atuc fast ratedown> <atur fast ratedown> <atuc interleave ratedown> <atur interleave ratedown> <init fail enable> <atuc ses> <atur ses> <atuc uas> <atur uas>]	Configures an alarm profile.
		delete	<profile>	Removes an alarm profile.
		map	<portlist> <profile>	Maps specified ADSL ports to an alarm profile.
		showmap	[port number]	Displays alarm profile to ADSL port mapping.
		showport	[port]	Displays which alarm profile parameters are mapped to an ADSL port.
	annexl			This only applies to the AAM1212-51.
		enable	<portlist>	Turns on the Annex L feature on the specified port(s).

**Table 60** ADSL Commands (continued)

COMMAND				DESCRIPTION
		delete	<profile>	Removes an ADSL profile.
		map	<portlist> <profile> <glite gdm t14 13 auto adsl2 a dsl2+> or <portlist> <profile> <gdm etsi auto  adsl2 adsl2+>	Assigns a specific profile to a port(s) and sets the port's ADSL mode.
	name	<portlist>	<name>	Sets the name of a port(s).
	tel	<portlist> <tel>		Records an ADSL port(s) subscriber's telephone number.
	loopback	<portlist>	<f5> <vpi> <vci>	Performs an OAMF5 loopback test.
	vcprofile			See <a href="#">Section 27.4 on page 212</a> for how to configure virtual channel profiles.
		show	[vcprofile]	Shows a virtual channel profile's contents.
		set	<vcprofile> <vc llc> <ubr cbr> <pcr> <cdvt>	Creates a UBR or CBR virtual channel profile (with encapsulation).
			set <vcprofile> <vc llc> <vbr (rt- vbr)  nrt-vbr> <pcr> <cdvt> <scr> <bt>	Creates a VBR virtual channel profile (with encapsulation).
		delete	<vcprofile>	Removes a virtual channel profile.
	pvc			See <a href="#">Section 27.5 on page 214</a> for how to configure Permanent Virtual Circuits.
		show	[<portlist> [<vpi> <vci>]]	Displays PVC settings.
		set	<portlist> <vpi> <vci> <super  vid = 1..4094 <priority>> <vcprofile>	Creates or modifies a PVC setting.
		delete	<portlist> <vpi> <vci>	Removes a PVC setting.
	showall	[nopause]		Displays all ADSL configuration.
	linediag			

**Table 60** ADSL Commands (continued)

COMMAND				DESCRIPTION
		setld	<port number>	Sets the specified port to line diagnostic mode.
		getld	<port number>	Displays the specified port line diagnostics.
	alarmprofile			See <a href="#">Section 27.3.13 on page 208</a> for how to configure alarm profiles.
		show	[profile]	Displays alarm profiles and their settings.
		set	<profile> [<atuc lofs> <atur lofs> <atuc loss> <atur loss> <atuc lols> <atur lprs> <atur lprs> <atuc ess> <atur ess> <atuc fast rateup> <atur fast rateup> <atuc interleave rateup> <atur interleave rateup> <atuc fast ratedown> <atur fast ratedown> <atuc interleave ratedown> <atur interleave ratedown> <init fail enable> <atuc ses> <atur ses> <atuc uas> <atur uas>]	Configures an alarm profile.
		delete	<profile>	Removes an alarm profile.
		map	<portlist> <profile>	Maps specified ADSL ports to an alarm profile.
		showmap	[port number]	Displays alarm profile to ADSL port mapping.
		showport	[port]	Displays which alarm profile parameters are mapped to an ADSL port.
	annexl			This only applies to the AAM1212-51.
		enable	<portlist>	Turns on the Annex L feature on the specified port(s).

**Table 60** ADSL Commands (continued)

COMMAND				DESCRIPTION
		disable	<portlist>	Turns off the Annex L feature on the specified port(s).
		show	<portlist>	Displays the Annex L feature setting for the specified port(s).
	sra			
		enable	<portlist>	Turns on Seamless Rate Adaptation (SRA) ADSL2+ on the specified port(s).
		disable	<portlist>	Turns off SRA ADSL2+ on the specified port(s).
		show	<portlist>	Displays the SRA ADSL2+ setting for the specified port(s).
	pmm			
		enable	<portlist>	Turns on the Power Management feature on the specified port(s).
		disable	<portlist>	Turns off the Power Management feature on the specified port(s).
		show	<portlist>	Displays the Power Management feature setting for the specified port(s).

## 27.3 ADSL Command Examples

These are the commonly used commands that belong to the ADSL group of commands.

### 27.3.1 ADSL Show Command

Syntax:

```
adsl show [portlist]
```

where

[portlist] = You can specify a single ADSL port <1>, all ADSL ports <\*> or a list of ADSL ports <1,3,5>. You can also include a range of ports <1,5,6~10>.

This command shows the activation status, ADSL mode, maximum upstream and downstream rate settings, profile and name of each ADSL port.

The following example displays information on ADSL port 5.

**Figure 109** ADSL Show Command Example

```

ras> adsl show 1
port enable mode      up/downstream profile
-----
   1   V   auto      512/ 9088 max

Subscriber Info:
port name              tel
-----
   1   -              -

```

### 27.3.2 ADSL Enable Command

Syntax:

```
adsl enable <portlist>
```

where

<portlist> = You can specify a single ADSL port <1>, all ADSL ports <\*> or a list of ADSL ports <1,3,5>. You can also include a range of ports <1,5,6~10>.

This command forcibly enables the specified ADSL port(s).

### 27.3.3 ADSL Disable Command

Syntax:

```
adsl disable <portlist>
```

where

<portlist> = You can specify a single ADSL port <1>, all ADSL ports <\*> or a list of ADSL ports <1,3,5>. You can also include a range of ports <1,5,6~10>.

This command forcibly disables the specified ADSL port(s).

**Note:** A port must be enabled before data transmission can occur. An enabled but disconnected ADSL port generates more heat than an operating port. To minimize heat generation and to enhance reliability, remember to disable a port when it is not in use.

## 27.3.4 ADSL Profile Show Command

Syntax:

```
adsl profile show [profile]
```

where

<profile> = A profile name.

This command displays the specified ADSL profile or all ADSL profiles if you do not specify one.

The following example displays the ADSL DEFVAL profile.

**Figure 110** ADSL Profile Show Command Example

```
ras> adsl profile show DEFVAL
01. DEFVAL      latency mode: interleave
                up stream down stream
                -----
max rate   (kbps):      512      2048
min rate   (kbps):       64       64
latency delay (ms):      4        4
max margin  (db):       31       31
min margin  (db):        0        0
target margin (db):      6        6
```

## 27.3.5 ADSL Profile Set Command

Syntax:

```
adsl profile set <profile> <fast|interleave[=<up delay>,<down delay>]> <up
max rate> <down max rate> [<up target margin> <up min margin> <up max
margin> <up min rate> <down target margin> <down min margin> <down max
margin> <down min rate>]
```

where

<profile> = The descriptive name for the profile.

<fast|interleave [=<up delay>,<down delay>]> = The latency mode. With interleave, you must also define the upstream and downstream delay (1-255 ms). It is recommended that you configure the same delay for both upstream and downstream.

<up max rate> = The maximum ADSL upstream transmission rate (64-4096 Kbps).

<code>&lt;down max rate&gt;</code>	=	The maximum ADSL downstream transmission rate (64-32000 Kbps).
<code>&lt;up target margin&gt;</code>	=	The target ADSL upstream signal/noise margin (0-31db).
<code>&lt;up min margin&gt;</code>	=	The minimum acceptable ADSL upstream signal/noise margin (0-31db).
<code>&lt;up max margin&gt;</code>	=	The maximum acceptable ADSL upstream signal/noise margin (0-31db).
<code>&lt;up min rate&gt;</code>	=	The minimum ADSL upstream transmission rate (64-4096 Kbps).
<code>&lt;down target margin&gt;</code>	=	The target ADSL downstream signal/noise margin (0-31db).
<code>&lt;down min margin&gt;</code>	=	The minimum acceptable ADSL downstream signal/noise margin (0-31db).
<code>&lt;down max margin&gt;</code>	=	The maximum acceptable ADSL downstream signal/noise margin (0-31db).
<code>&lt;down min rate&gt;</code>	=	The minimum ADSL downstream transmission rate (64-32000 Kbps).

The profile is a table that contains information on ADSL line configuration. Each entry in this table reflects a parameter defined by a manager, which can be used to configure the ADSL line.

Note that the default value will be used for any of the above fields that are omitted.

The upstream rate must be less than or equal to the downstream rate.

Even though you can specify arbitrary numbers in the profile set command, the actual rate is always a multiple of 32 Kbps. If you enter a rate that is not a multiple of 32 Kbps, the actual rate will be the next lower multiple of 32Kbps. For instance, if you specify 66 Kbps, the actual rate will not be over 64Kbps.

The following example creates a premium profile (named gold) for providing subscribers with very high connection speeds and no interleave delay. It also sets the upstream target signal/noise margin to 5 db, the upstream minimum acceptable signal/noise margin to 0 db, the upstream maximum acceptable signal/noise margin to 30 db, the upstream minimum ADSL transmission rate to 64 Kbps, the downstream target signal/noise margin to 5 db, the downstream minimum acceptable signal/noise margin to 0 db, the downstream maximum acceptable signal/noise margin to 30 db and the downstream minimum ADSL transmission rate to 128 Kbps.

```
ras> adsl profile set gold fast 800 8000 5 0 30 64 5 0 30 128
```

This next example creates a similar premium profile (named goldi), except it sets an interleave delay of 16 ms for both upstream and downstream traffic.

```
ras> adsl profile set goldi interleave=16,16 800 8000 5 0 30 64 5 0 30
128
```

After you create an ADSL profile, you can assign it to any of the ADSL ports on any of the AAMs in the IES-1000.

### 27.3.6 ADSL Profile Delete Command

Syntax:

```
adsl profile delete <profile>
```

where

<profile> = A profile name.

This command allows you to delete an individual ADSL profile by its name. You cannot delete a profile that is assigned to any of the DSL ports in the AAM. Assign a different profile to any DSL ports that are using the profile that you want to delete, and then you can delete the profile.

The following example deletes the gold ADSL profile.

**Figure 111** ADSL Profile Delete Command Example

```
ras> adsl profile delete gold
```

### 27.3.7 ADSL Profile Map Command

Syntax:

```
adsl profile map <portlist> <profile> <glite|gdm|t1413|auto|adsl2|adsl2+>
adsl profile map <portlist> <profile> <gdm|etsi|auto|adsl2|adsl2+>
```

where

<portlist> = You can specify a single ADSL port <1>, all ADSL ports <\*> or a list of ADSL ports <1,3,5>. You can also include a range of ports <1,5,6~10>.

<profile> = The profile that will define the settings of this port.

<glite|gdm|t1413|auto|adsl2|adsl2+> = The ADSL operational mode. With the AAM1212-51, choose from glite, gdm, t1413, auto, adsl2 or adsl2+.

<gdm|etsi|auto|adsl2|adsl2+> = The ADSL operational mode. With the AAM1212-53, choose from gdm, etsi, auto, adsl2 or adsl2+.

This command assigns a specific profile to an individual port and sets the port's ADSL mode (or standard). The profile defines the maximum and minimum upstream/downstream rates, the target upstream/downstream signal noise margins, and the maximum and minimum upstream/downstream acceptable noise margins of all the ADSL ports to which you assign the profile.

When set to auto, the port follows whatever mode is set on the other end of the line.

**Note:** When the mode is set to auto and the negotiated mode is G.lite, if the configured rates exceed those allowed by G.lite, the actual rates are governed by G.lite, regardless of the configured numbers.

The following example sets ADSL port 1 to have the gold profile in adsl2+ mode.

**Figure 112** ADSL Profile Map Command Example

```
ras> adsl profile map 2 gold adsl2+
```

### 27.3.8 ADSL Name Command

Syntax:

```
adsl name <portlist> <name>
```

where

<portlist> = You can specify a single ADSL port <1>, all ADSL ports <\*> or a list of ADSL ports <1,3,5>. You can also include a range of ports <1,5,6~10>.

<name> = A descriptive name for the port.

This command sets the name of an ADSL port(s).

The following example sets ADSL port 5 to have the name "super".

**Figure 113** ADSL Name Command Example

```
ras> adsl name 5 super
```

### 27.3.9 ADSL Tel Command

Syntax:

```
adsl tel <portlist> <tel>
```

where

- `<portlist>` = You can specify a single ADSL port `<1>`, all ADSL ports `<*>` or a list of ADSL ports `<1,3,5>`. You can also include a range of ports `<1,5,6~10>`.
- `<tel>` = An ADSL subscriber's telephone number.

This command records the telephone number of an ADSL subscriber telephone number.

The following example records the telephone number "12345678" for ADSL port 5.

**Figure 114** ADSL Tel Command Example

```
ras> adsl tel 5 12345678
```

### 27.3.10 ADSL Loopback Command

Syntax:

```
adsl loopback <portlist> <f5> <vpi> <vci>
```

where

- `<portlist>` = You can specify a single ADSL port `<1>`, all ADSL ports `<*>` or a list of ADSL ports `<1,3,5>`. You can also include a range of ports `<1,5,6~10>`.
- `<f5>` = Use `f5` to perform an OAM F5 loopback test on the specified DSL port. An Operational, Administration and Maintenance Function 5 test is used to test the connection between two DSL devices. First, the DSL devices establish a virtual circuit. Then the local device sends an ATM F5 cell to be returned by the remote DSL device (both DSL devices must support ATM F5 in order to use this test).
- `<vpi> <vci>` = When you perform an OAM F5 loopback test, specify a VPI/VCI.

This command has the AAM perform a loopback test on the specified ADSL port(s).

The following example has the AAM perform a local loopback test on ADSL port 1.

**Figure 115** ADSL Profile Loopback Example

```
ras> adsl loopback 1 f5 0 33
line 1 oam loopback success!
```

### 27.3.11 Line Diagnostics Set Command

Syntax:

```
adsl linediag setld <port number>
```

This command has the AAM perform line diagnostics on the specified port. The ADSL port must be set to ADSL2 or ADSL2+ ADSL operational mode and have a connection. It takes about one minute for the line diagnostics to finish.

The following example performs line diagnostics on ADSL port 1. The screen displays a message confirming upon which ADSL port line diagnostics will be performed.

**Figure 116** ADSL Line Diagnostics Set Command Example

```
ras> adsl linediag setld 1
Line- 1 set to Line Diagnostic Mode
```

### 27.3.12 Line Diagnostics Get Command

Syntax:

```
adsl linediag getld <port number>
```

Use this command to display the line diagnostics results after using the line diagnostics set command on an ADSL port. Use the line diagnostics results to analyze problems with the physical ADSL line.

**Note:** Wait at least one minute after using the line diagnostic set command before using the line diagnostics set command.

The following example displays the line diagnostics results for ADSL port 1.

**Figure 117** ADSL Line Diagnostics Get Command Example

```

ras> adsl linediag getld 1
Line_Diagnostics_Parameter,_channel: 0

number_of_subcarries: 256      32
hlinScale: 19625      32767
latn: 54      0
satn: 52      8
snrm: 60      60
attndr: 12140000      1120000
farEndActatp: 75      125
i      li.rl      li.im      log      QLN      SNR
0      32768      32768      1023      255      255
1      32768      32768      1023      255      255
2      32768      32768      1023      255      255
3      32768      32768      1023      255      255
4      32768      32768      1023      255      255
5      32768      32768      1023      255      255
6      11604      4752      83      191      132
7      17794      5598      48      190      139
8      22385      5567      30      184      147
9      24903      5163      21      163      152
10     26768      5013      15      185      159
11     29179      5494      8      175      165
12     31605      6574      1      172      168
13     32766      8020      1023      186      170
14     32159      9597      1023      183      173
15     30990      11350     1023      182      173
16     30432      13730     1023      186      172
17     30259      16694     1023      182      170
18     29137      19570     1023      171      170
19     26499      21554     1023      186      172
20     23288      22973     0      173      174
21     20620      24727     1      175      175
22     18594      27337     1023      189      173

```

### 27.3.13 ADSL Alarm Profile Commands

Configure alarm profiles to set alarm settings and thresholds for the ADSL ports.

### 27.3.14 Alarm Profile Show Command

Syntax:

```
adsl alarmprofile show [profile]
```

where

[profile] = The name of an alarm profile.

Displays the settings of the specified alarm profile (or all of them if you do not specify one).

The following example displays the default alarm profile (DEFVAL).

**Figure 118** Alarm Profile Show Command Example

```

ras> adsl alarmprofile show DEFVAL
01. DEFVAL

                                     ATU-C   ATU-R
                                     -----
Thresh15MinLofs                       (sec):    0       0
Thresh15MinLoss                       (sec):    0       0
Thresh15MinLols                       (sec):    0       ---
Thresh15MinLprs                       (sec):    0       0
Thresh15MinESs                       (sec):    0       0
ThreshFastRateUp                      (bps):    0       0
ThreshInterleaveRateUp                (bps):    0       0
ThreshFastRateDown                   (bps):    0       0
ThreshInterleaveRateDown              (bps):    0       0
InitFailureTrap(1-enable, 2-disable)  :         2       ---
Thresh15MinFailedFastRetrain         :         0       ---
Thresh15MinSes                       (sec):    0       0
Thresh15MinUas                       (sec):    0       0

```

### 27.3.15 Alarm Profile Set Command

Syntax:

```

adsl alarmprofile set <profile> [atuc lofs] <atur lofs> <atuc loss> <atur
loss> <atuc lols> <atur lols> <atuc lprs> <atur lprs> <atuc ess> <atur ess> <atuc fast
rateup> <atur fast rateup> <atuc interleave rateup> <atur interleave
rateup> <atuc fast ratedown> <atur fast ratedown> <atuc interleave
ratedown> <atur interleave ratedown> <init fail enable> <atuc ses> <atur
ses> <atuc uas> <atur uas>]

```

where

<profile>	=	A name for the alarm profile (up to 31 ASCII characters).
atuc		Upstream. These parameters are for the connection (or traffic) coming from the subscriber's device to the AAM.
atur		Downstream. These parameters are for the connection (or traffic) going from the AAM to the subscriber's device.
<atuc lofs> <atur lofs>	=	The number of Loss Of Frame Seconds that are permitted to occur within 15 minutes.
<atuc loss> <atur loss>	=	The number of Loss Of Signal Seconds that are permitted to occur within 15 minutes.
<atuc lols>	=	The number of Loss Of Link Seconds that are permitted to occur within 15 minutes.
<atuc lprs> <atur lprs>	=	The Number of times a Loss of PowerR is permitted to occur (on the ATUR) within 15 minutes.

<code>&lt;atuc ess&gt; &lt;atur ess&gt;</code>	=	The number of Errored Seconds that are permitted to occur within 15 minutes.
<code>&lt;atuc fast rateup&gt; &lt;atur fast rateup&gt;</code>	=	A rate in kilobits per second (kbps). If a fast mode connection's upstream transmission rate increases by more than this number, then a trap is sent.
<code>&lt;atuc interleave rateup&gt; &lt;atur interleave rateup&gt;</code>	=	A rate in kilobits per second (kbps). If an interleave mode connection's upstream transmission rate increases by more than this number, then a trap is sent.
<code>&lt;atuc fast ratedown&gt; &lt;atur fast ratedown&gt;</code>	=	A rate in kilobits per second (kbps). If a fast mode connection's downstream transmission rate decreases by more than this number, then a trap is sent.
<code>&lt;atuc interleave ratedown&gt; &lt;atur interleave ratedown&gt;</code>	=	A rate in kilobits per second (kbps). If an interleave mode connection's upstream transmission rate decreases by more than this number, then a trap is sent.
<code>&lt;init fail enable&gt;</code>	=	"1" sets the profile to trigger an alarm for an initialization failure trap. "2" sets the profile to not trigger an alarm for an initialization failure trap.
<code>&lt;atuc ses&gt; &lt;atur ses&gt;</code>	=	The number of Severely Errored Seconds that are permitted to occur within 15 minutes.
<code>&lt;atuc uas&gt; &lt;atur uas&gt;</code>	=	The number of UnAvailable Seconds that are permitted to occur within 15 minutes.

The `alarmprofile set` command configures ADSL port alarm thresholds. The AAM sends an alarm trap and generates a syslog entry when the thresholds of the alarm profile are exceeded.

Configure alarm profiles first and then use the `alarmprofile map` command to set the AAM to use them with specific ADSL ports.

The following example sets an alarm profile named `SESalarm` that has the AAM send an alarm trap and generate a syslog whenever the upstream connection's number of severely errored seconds exceeds three within a 15 minute period.

**Figure 119** Alarm Profile Set Command Example

```

ras> adsl alarmprofile set SESalarm 0 0 0 0 0 0 0 0 0 0 0 0 0 0 0 0 2 0
3 0 0 0

```

### 27.3.16 Alarm Profile Delete Command

Syntax:

```
adsl alarmprofile delete <profile>
```

where

<profile> = The name of an alarm profile.

This command allows you to delete an individual ADSL alarm profile by its name. You cannot delete the DEFVAL alarm profile.

The following example deletes the SESalarm alarm profile.

**Figure 120** Alarm Profile Delete Command Example

```
ras> adsl alarm profile delete SESalarm
```

### 27.3.17 Alarm Profile Map Command

Syntax:

```
adsl alarmprofile map <portlist> <profile>
```

where

<portlist> = You can specify a single ADSL port <1>, all ADSL ports <\*> or a list of ADSL ports <1,3,5>. You can also include a range of ports <1,5,6~10>.

<profile> = The name of an alarm profile.

Sets the AAM to use an (already configured) alarm profile with the specified ADSL ports.

The following example sets the AAM to use the SESalarm alarm profile with ADSL port 5.

**Figure 121** Alarm Profile Map Command Example

```
ras> adsl alarmprofile map SESalarm 5
```

### 27.3.18 Alarm Profile Showmap Command

Syntax:

```
adsl alarmprofile showmap [port number]
```

where

[port number] = The number of an ADSL port.

This command displays which alarm profiles the AAM is set to use for specific (or all) ADSL ports.

The following example displays which alarm profile the AAM is set to use for ADSL port 5.

**Figure 122** Alarm Profile Showmap Command Example

```
ras> adsl alarmprofile showmap 5
ADSL alarm profile mapping:
Port 5: Alarm Profile = DEFVAL
```

## 27.4 Virtual Channel Profile Commands

Use the following commands to configure virtual channel profiles.

### 27.4.1 Show Virtual Channel Profile Command

Syntax:

```
adsl vcprofile show [vcprofile]
```

where

[vcprofile] = The name of the virtual channel profile (up to 31 ASCII characters).

Displays the settings of the specified virtual channel profile (or all of them if you do not specify one).

### 27.4.2 Set Virtual Channel Profile Command

Syntax:

```
adsl vcprofile set <vcprofile> <vc|llc> <ubr|cbr> <pcr> <cdvt>
```

or

```
adsl vcprofile set <vcprofile> <vc|llc> <vbr(rt-vbr)|nrt-vbr> <pcr> <cdvt>
<scr> <bt>
```

where

<code>&lt;vcprofile&gt;</code>	=	The name of the virtual channel profile (up to 31 ASCII characters). You cannot change the <b>DEFVAL</b> or <b>DEFVAL_VC</b> profiles.
<code>&lt;vc llc&gt;</code>	=	The type of encapsulation (vc or llc).
<code>&lt;ubr cbr&gt;</code>	=	The ubr (unspecified bit rate) or cbr (constant bit rate) ATM traffic class.
<code>&lt;pcr&gt;</code>	=	Peak Cell Rate (0 to 300000 or *), the maximum rate (cells per second) at which the sender can send cells.
<code>[cdvt]</code>	=	Cell Delay Variation Tolerance is the accepted tolerance of the difference between a cell's transfer delay and the expected transfer delay (number of cells). 0 to 255 cells or * (means 0).
<code>&lt;vbr (rt-vbr)  nrt-vbr&gt;</code>	=	The real-time (vbr) or non real-time (nrt-vbr) Variable Bit Rate ATM traffic class.
<code>&lt;scr&gt;</code>	=	The Sustained Cell Rate sets the average cell rate (long-term) that can be transmitted (cells per second). SCR applies with the vbr traffic class.
<code>&lt;bt&gt;</code>	=	Burst Tolerance this is the maximum number of cells that the port is guaranteed to handle without any discards (number of cells). BT applies with the vbr traffic class.

The `vcprofile set` command creates a virtual channel profile. After you create a virtual channel profile, you can assign it to any of the ADSL ports on any of the ADSL AAMs in the AAM.

The following example creates a virtual channel profile named `gold` that uses LLC encapsulation. It uses constant bit rate and has the maximum rate (peak cell rate) set to 300,000 cells per second. The acceptable tolerance of the difference between a cell's transfer delay and the expected transfer delay (CDVT) is set to 5 cells.

```
ras> adsl vcprofile set gold llc cbr 300000 5
```

The following example creates a virtual channel profile named `silver` that uses VC encapsulation. It uses real-time variable bit rate and has the maximum rate (peak cell rate) set to 250,000 cells per second. The acceptable tolerance of the difference between a cell's transfer delay and the expected transfer delay (CDVT) is set to 5 cells. The average cell rate that can be transmitted (SCR) is set to 100,000 cells per second. The maximum number of cells that the port is guaranteed to handle without any discards (BT) is set to 200.

```
ras> adsl vcprofile set silver vc vbr 250000 5 100000 200
```

The following example creates a virtual channel profile named `economy` that uses LLC encapsulation. It uses unspecified bit rate and has the maximum rate (peak cell rate) set to 50,000 cells per second. The acceptable tolerance of the difference between a cell's transfer delay and the expected transfer delay (CDVT) is set to 100 cells.

```
ras> adsl vcprofile set gold llc cbr 50000 100
```

### 27.4.3 Delete Virtual Channel Profile Command

Syntax:

```
adsl vcprofile delete <vcprofile>
```

where

<vcprofile> = The name of the virtual channel profile (up to 31 ASCII characters). You cannot change the DEFVAL or DEFVAL\_VC profiles.

You cannot delete a virtual channel profile that is assigned to any of the ADSL ports. Assign a different profile to any ADSL ports that are using the profile that you want to delete, and then you can delete the profile.

The following example deletes the silver virtual channel profile.

**Figure 123** Virtual Channel Profile Delete Command Example

```
ras> adsl vcprofile delete silver
```

## 27.5 PVC Channels

Virtual channels (also called Permanent Virtual Circuits or PVCs) let you set priorities for different services or subscribers. You can define up to eight channels on each DSL port and use them for different services or levels of service. You set the PVID that is assigned to untagged frames received on each channel. You also set an IEEE 802.1p priority for each of the PVIDs. In this way you can assign different priorities to different channels (and consequently the services that get carried on them or the subscribers that use them). Use the following commands to define channels.

### 27.5.1 PVC Show Command

Syntax:

```
adsl pvc show [<portlist> [<vpi> <vci>]]
```

where

- [portlist] = You can specify a single ADSL port <1>, all ADSL ports <\*> or a list of ADSL ports <1,3,5>. You can also include a range of ports <1,5,6~10>.
- [<vpi> <vci>] = The VPI and VCI of an individual PVC.

The `pvc show` command allows you to display the PVC parameters of the specified ADSL port(s) or all of the ADSL ports if you do not specify any.

## 27.5.2 PVC Set Command

Syntax:

```
adsl pvc set <portlist> <vpi> <vci> <super |vid = 1..4094 <priority>>
<vcprofile>
```

where

- <portlist> = You can specify a single ADSL port <1>, all ADSL ports <\*> or a list of ADSL ports <1,3,5>. You can also include a range of ports <1,5,6~10>.
- <vpi> = The VPI setting can be 0 to 255.
- <vci> = The VCI setting can be 32 to 65535 if the vpi is 0 or 1 to 65535 if the vpi is not 0.
- <super |vid = 1..4094 <priority>> = Use `super` to set this channel as a super channel. The super channel can forward frames belonging to multiple VLAN groups (that are not assigned to other channels). A channel that is not the super channel can only forward frames with a single VLAN ID (that is configured on that channel). The AAM would drop any frames received from the subscriber that are tagged with another VLAN ID.

Use the default VID (1 to 4094) to set this channel as a normal channel. Each PVC must have a unique VID since the AAM forwards traffic back to the subscribers based on the VLAN ID.

You must assign a default VID (1 to 4094) and IEEE 802.1p default priority (0 to 7) to normal channels. Each PVC must have a unique VID (since the AAM forwards traffic back to the subscribers based on the VLAN ID).

The priority value (0 to 7) is to add to incoming frames without a (IEEE 802.1p) priority tag.

- <vcprofile> = Assign a virtual channel profile to the PVC.

This command allows the configuration of a PVC (permanent virtual circuit) for one or a range of ADSL ports.

The following example sets a PVC on ADSL port 1 with VPI 1, VCI 34, default VID 100 priority 3 and the DEFVAL\_VC profile.

**Figure 124** PVC Set Command Example

```
ras> adsl pvc set 1 1 34 100 3 DEFVAL_VC
```

### 27.5.3 PVC Delete Command

Syntax:

```
adsl pvc delete <portlist> <vpi> <vci>
```

where

- <portlist> = You can specify a single ADSL port <1>, all ADSL ports <\*> or a list of ADSL ports <1,3,5>. You can also include a range of ports <1,5,6~10>.
- [<vpi> <vci>] = The VPI and VCI of an individual PVC.

This command deletes the specified PVC channel.

# CHAPTER 28

## Switch Commands

This chapter describes how to configure some of the `switch` commands.

### 28.1 Switch Commands Summary

The following table lists the `switch` commands you can use with the AAM.

**Table 61** Switch Commands

COMMAND				DESCRIPTION
switch				
	igmpsnoop			
		show		Displays the IGMP snooping setting.
		enable		Turns on IGMP snooping.
		disable		Turns off IGMP snooping.
	igmpfilter			
		set	[<port> *] <name>	Sets an ADSL port(s) to use an IGMP filter profile.
		show	[portlist]	Displays which IGMP filter profile an ADSL port(s) is using.
		profile		
			set <name> <index> <startip> <endip>	Configures an IGMP filter profile.
			delete <name>	Removes an IGMP filter profile.
			show [name]	Displays an IGMP filter profile's settings.
	queuemap			
		show		Displays the system's priority level to physical queue mapping.
		set	<priority> <queue>	Maps a priority level to a physical queue.
	garptimer			
		show		Displays the GARP timer status.
		join	<join msec>	Sets the GARP timer's Join Timer.
		leave	<leave msec>	Sets the GARP timer's Leave Timer.

**Table 61** Switch Commands (continued)

COMMAND				DESCRIPTION
		leaveall	<leaveall msec>	Sets the GARP timer's Leave All Timer.
	rstp			Rapid STP commands (refer to IEEE 802.1w).
		show		Displays the RSTP settings.
		enable		Turns on RSTP.
		disable		Turns off RSTP.
		priority	<priority>	Sets the system's priority.
		hellotime	<hellotime sec>	Sets the hello timer.
		maxage	<maxage sec>	Sets the max age timer.
		fwdelay	<fwdelay sec>	Sets the forward delay time.
		port	show	Displays the Ethernet ports' RSTP settings.
			enable <enet1 enet2 *>	Enables RSTP on a port.
			disable <portlist>	Disables RSTP on a port.
			priority <portlist> <priority>	Sets the specified port's priority.
			pathcost <portlist> <pathcost>	Sets the specified port's path cost.
	dhcprelay			
		show		Displays DHCP relay settings.
		enable		Turns on DHCP relay.
		disable		Turns off DHCP relay.
		server	<server ip>	Sets a DHCP relay server IP address entry.
		option82		
			enable	Turns on the DHCP relay agent information (Option 82) feature.
			disable	Turns off the DHCP relay agent information (Option 82) feature.
			set <relay info>	Adds the specified information for the relay agent.
	vlan			See <a href="#">Section 28.8 on page 228</a> for how to configure Virtual LAN.
		show	<vlanlist>	Displays VLAN settings.
		portshow	[portlist]	Displays the port(s) VLAN settings.

**Table 61** Switch Commands (continued)

COMMAND				DESCRIPTION
		set	<vid><portlist> :<F<T U> X N> [<portlist>: <F<T U> X N> ...] [name]	Configures a VLAN entry.
		enable	<vid>	Turns on a VLAN entry.
		disable	<vid>	Turns off a VLAN entry.
		delete	<vlanlist>	Removes a VLAN entry.
		pvid	<portlist> <pvid>	Sets the PVID (Port VLAN ID) assigned to untagged frames or priority frames (0 VID) received on this port(s).
		priority	<portlist> <priority>	Sets a port's default IEEE 802.1p priority.
		gvrp	<portlist> <enable disable >	Turns GVRP on or off for the specified ports.
		frametype	<portlist> <all tag untag>	Sets the specified DSL port to accept VLAN tagged or untagged Ethernet frames (or both).
		cpu	show	Displays the VLAN ID of the management VLAN.
			set <vid>	Sets the VLAN ID of the management VLAN.
	mac			
		flush		Clears learned MAC addresses from the forwarding table.
		agingtime		
			show	Displays the MAC aging out time period.
			set <sec 0:disabled >	Sets the MAC aging out time period.
		count		
			show [portlist]	Displays the system's current MAC address count settings.
			enable <portlist>	Turns on the MAC address count filter for a port(s).
			disable <portlist>	Turns off the MAC address count filter for a port(s).
			set <portlist> <count>	Sets the MAC address count filter for a port(s).
		filter	show [portlist]	Displays MAC filter settings.
			enable <portlist>	Turns on the MAC filter for a port(s).

**Table 61** Switch Commands (continued)

COMMAND				DESCRIPTION
			disable <portlist>	Turns off the MAC filter for a port(s).
			set <port> <mac> [<mac> <mac> ...]	Adds a MAC filter MAC entry.
			delete <port> <mac> [<mac> <mac> ...]	Removes a MAC filter MAC entry.
	pktfilter			See <a href="#">Section 28.13 on page 242</a> for how to configure packet filters.
		show	[portlist]	Displays packet type filter settings.
		set	<portlist> [pppoe ip arp netbios dhcp eapol igmp none]	Sets the packet type filter for a specific port. none accepts all packets. This command disables the <code>pktfilter pppoeonly &lt;portlist&gt;</code> command.
		pppoeonly	<portlist>	Uses this command to allow only PPPoE traffic. It drops any non-PPPoE packets. This command disables the <code>pktfilter set &lt;portlist&gt; [pppoe ip arp netbios dhcp eapol igmp none]</code> command.
	dot1x			
		show	[portlist]	Displays IEEE 802.1X settings.
		enable		Turns on IEEE 802.1X.
		disable		Turns off IEEE 802.1X.
		auth	<profile radius>	Sets IEEE 802.1X to use the local profiles or an external RADIUS server for authentication.
		port		
			enable <portlist>	Turns on IEEE 802.1X for specific ports.
			disable <portlist>	Turns off IEEE 802.1X for specific ports.
			control <portlist> <auto auth unauth>	Sets the IEEE 802.1X port authentication option for specific ports.
			reauth <portlist> <on off>	Sets the IEEE 802.1X re-authentication option for specific ports.
			period <portlist> <period>	Sets the IEEE 802.1X re-authentication period for specific ports.

**Table 61** Switch Commands (continued)

COMMAND			DESCRIPTION
	radius		
		show	Displays the external RADIUS server settings.
		ip <ip>	Sets the external RADIUS server IP address.
		port <port>	Sets the external RADIUS server port number.
		secret <secret>	Sets the authentication and encryption key.
	profile		
		show	Displays the local profiles.
		set <name> <password>	Creates or edits a local profile.
		delete <name>	Removes a local profile.
	enet		
		show	Displays the Ethernet port settings.
		speed <portlist> <10copper 100copper auto>	Sets the Ethernet port(s) connection speed.
		name <portlist> <name>	Sets the Ethernet port(s) name.
		enable <portlist>	Turns on the specified Ethernet port(s).
		disable <portlist>	Turns off the specified Ethernet port(s).
	smcast		Use the static multicast filter to pass routing protocols, such as RIP and OSPF.
		show	Display all MAC addresses joined to ADSL ports.
		set <adsl_port> <mac> <join leave>	Use join/leave to add/ remove multicast MAC addresses (up to ten) on specified ADSL ports, a range of ADSL ports or all ADSL ports. MAC example: 01005E010203
		delete <mac>	Removes a static multicast filter entry by deleting the associated MAC address.
	isolation		
		show	Displays the subscriber isolation feature's current setting.
		enable	Turns the subscriber isolation feature on.
		disable	Turns the subscriber isolation feature off.

**Table 61** Switch Commands (continued)

COMMAND			DESCRIPTION
		daisychain	Sets the device to daisychain mode.
		standalone	Sets the device to standalone mode.
	showall	[nopause]	Displays all of the AAM's switch configuration.

## 28.2 IGMP Filter Commands

Use the IGMP filter commands to define IGMP filter profiles and assign them to ADSL ports.

IGMP filter profiles allow you to control access to IGMP multicast groups. You can have a service available to a specific IGMP multicast group. You can configure an IGMP filter profile for an IGMP multicast group that has access to a service (like a SIP server for example). Then you can assign the IGMP filter profile to ADSL ports that are allowed to use the service.

### 28.2.1 IGMP Filter Show Command

Syntax:

```
switch igmpfilter show [portlist]
```

where

[portlist] = You can specify a single ADSL port <1>, all ADSL ports <\*> or a list of ADSL ports <1,3,5>. You can also include a range of ports <1,5,6~10>.

This command displays which IGMP filter profile an ADSL port(s) is using.

The following example displays which IGMP filter profile ADSL port 9 is using.

**Figure 125** IGMP Filter Show Command Example

```

ras> switch igmpfilter show 9
port                               profile
-----
  9                                 DEFVAL

```

### 28.2.2 IGMP Filter Set Command

Syntax:

```
switch igmpfilter set [<port>|*] <name>
```

where

- [<port>|\*] = You can specify a single ADSL port <1> or all ADSL ports <\*>.
- <name> = The name of an IGMP filter profile.

This command sets an ADSL port(s) to use an IGMP filter profile.

The following example sets ADSL port 9 to use the voice IGMP filter profile.

**Figure 126** IGMP Filter Set Command Example

```
ras> switch igmpfilter set 9 voice
```

### 28.2.3 IGMP Filter Profile Set Command

Syntax:

```
switch igmpfilter profile set <name> <index> <startip> <endip>
```

where

- <name> = Specify a name to identify the IGMP filter profile (you cannot change the name of the DEFVAL profile). You can use up to 31 ASCII characters; spaces are not allowed.
- <index> = The number (1~16) to identify a multicast IP address range.
- <startip> = Type the starting multicast IP address for a range of multicast IP addresses that you want to belong to the IGMP filter profile.
- <endip> = Type the ending multicast IP address for a range of IP addresses that you want to belong to the IGMP filter profile.

If you want to add a single multicast IP address, enter it as both the `startip` and `endip`.

This command configures an IGMP filter profile.

The following example configures an IGMP filter profile named `voice` with a range of multicast IP addresses (index 1) from 224.1.1.10 to 224.1.1.44.

**Figure 127** IGMP Filter Profile Set Command Example

```
ras> switch igmpfilter profile set test1 1 224.1.1.10 224.1.1.44
```

## 28.2.4 IGMP Filter Profile Delete Command

Syntax:

```
switch igmpfilter profile delete <name>
```

where

<name> = The name of an IGMP filter profile.

This command removes an IGMP filter profile.

The following example removes the voice IGMP filter profile.

**Figure 128** IGMP Filter Profile Delete Command Example

```
ras> switch igmpfilter profile delete voice
```

## 28.2.5 IGMP Filter Profile Show Command

Syntax:

```
switch igmpfilter profile show [<name>|*]
```

where

[<name>|\*] = The name of an IGMP filter profile or all of the IGMP filter profiles <\*>.

This command displays an IGMP filter profile's settings.

The following example displays the voice IGMP filter profile's settings.

**Figure 129** IGMP Filter Show Command Example

```

ras> switch igmpfilter profile show voice
      profile  index          startip          endip
-----
      voice    1          224.1.1.10      224.1.1.44
      voice    2           0.0.0.0         0.0.0.0
      voice    3           0.0.0.0         0.0.0.0
      voice    4           0.0.0.0         0.0.0.0
      voice    5           0.0.0.0         0.0.0.0
      voice    6           0.0.0.0         0.0.0.0
      voice    7           0.0.0.0         0.0.0.0
      voice    8           0.0.0.0         0.0.0.0
      voice    9           0.0.0.0         0.0.0.0
      voice   10           0.0.0.0         0.0.0.0
      voice   11           0.0.0.0         0.0.0.0
      voice   12           0.0.0.0         0.0.0.0
      voice   13           0.0.0.0         0.0.0.0
      voice   14           0.0.0.0         0.0.0.0
      voice   15           0.0.0.0         0.0.0.0
      voice   16           0.0.0.0         0.0.0.0

```

## 28.3 DHCP Relay Overview

DHCP (Dynamic Host Configuration Protocol, RFC 2131 and RFC 2132) allows individual clients to obtain TCP/IP configuration at start-up from a DHCP server. You can configure the AAM to relay client TCP/IP configuration requests to a DHCP server and the server's responses back to the clients. See the web configurator parts for details on DHCP relay.

## 28.4 DHCP Relay Commands

Use these commands to configure the DHCP relay feature.

### 28.4.1 DHCP Relay Server Set Command

Syntax:

```
switch dhcprelay server <server ip>
```

where

<server ip>           =   The IP address of a DHCP server.

This command adds a DHCP server entry to the list of servers to which the AAM relays client TCP/IP configuration requests.

## 28.4.2 DHCP Relay Enable Command

Syntax:

```
switch dhcprelay enable
```

This command turns on the DHCP relay feature.

## 28.4.3 DHCP Relay Disable Command

Syntax:

```
switch dhcprelay disable
```

This command turns off the DHCP relay feature.

## 28.4.4 DHCP Relay Show Command

Syntax:

```
switch dhcprelay show
```

This command displays whether or not the DHCP relay feature is activated, the DHCP server's IP address, the status of the DHCP relay agent info option 82 feature and the information configured for it.

**Figure 130** DHCP Relay Show Command Example

```
ras> switch dhcprelay show
status server ip      option82 info
-----
-      1.1.1.1        -
```

## 28.5 DHCP Relay Option 82 (Agent Information)

Use the following commands to configure the DHCP relay Option 82 (agent information) feature.

### 28.5.1 Option 82 Enable Command

Syntax:

```
switch dhcprelay option82 enable
```

This command turns on the DHCP relay agent information (Option 82) feature.

## 28.5.2 Option 82 Disable Command

Syntax:

```
switch dhcprelay option82 disable
```

This command turns off the DHCP relay agent information (Option 82) feature.

## 28.5.3 Option 82 Set Command

Syntax:

```
switch dhcprelay option82 set <relay info>
```

where

<relay info> = Up to 23 ASCII characters of additional information for the AAM to add to the DHCP client TCP/IP configuration requests that it relays to a DHCP server.

Examples of information you could add would be the name of the AAM or the ISP.

This command adds the specified information for the relay agent.

## 28.6 IEEE 802.1Q Tagged VLAN Overview

See the web configurator chapter on VLAN for more information on VLANs. There are two kinds of tagging:

### 1 Explicit Tagging

A VLAN identifier is added to the frame header that identifies the source VLAN.

### 2 Implicit Tagging

The MAC (Media Access Control) number, the port or other information is used to identify the source of a VLAN frame.

The IEEE 802.1Q Tagged VLAN uses both explicit and implicit tagging.

## 28.7 Filtering Databases

A filtering database stores and organizes VLAN registration information useful for switching frames to and from the AAM. A filtering database consists of a static entries (Static VLAN or SVLAN table) and dynamic entries (Dynamic VLAN or DVLAN table).

## 28.7.1 Static Entries (SVLAN Table)

Static entry registration information is added, modified and removed by administrators only.

## 28.7.2 Dynamic Entries (DVLAN Table)

Dynamic entries are learned by the AAM and cannot be created or updated by administrators. The AAM learns this information by observing what port, source address and VLAN ID (or VID) is associated with a frame. Entries are added and deleted using GARP VLAN Registration Protocol (GVRP), where GARP is the Generic Attribute Registration Protocol.

## 28.8 IEEE VLAN1Q Tagged VLAN Configuration Commands

These switch commands allow you to configure and monitor the IEEE 802.1Q Tagged VLAN.

### 28.8.1 GARP Timer Show Command

Syntax:

```
ras> switch garptimer show
```

This command shows the AAM's GARP timer settings, including the join, leave and leave all timers.

An example is shown next.

**Figure 131** GARP Timer Show Command Example

```
ras> switch garptimer show
join time      (ms): 200
leave time     (ms): 600
leaveall time  (ms): 10000
```

### 28.8.2 GARP Timer Join Command

Syntax:

```
ras> switch garptimer join <join msec>
```

where

<join msec> = This sets the duration of the Join Period timer for GVRP in milliseconds. Each port has a Join Period timer. The allowed Join Time range is between 100 and 32767 milliseconds; the default is 200 milliseconds.

This command sets the AAM's join period timer for GVRP in milliseconds.

Switches join VLANs by making a declaration. A declaration is made by issuing a Join message using GARP. GARP timers set declaration timeout values.

The following example sets the Join Timer to 300 milliseconds.

**Figure 132** GARP Timer Join Command Example

```
ras> switch garptimer join 300
```

### 28.8.3 GARP Timer Leave Command

Syntax:

```
ras> switch garptimer leave <leave msec>
```

where

<leave msec> = This sets the duration of the Leave Period timer for GVRP in milliseconds. Each port has a single Leave Period timer. Leave Time must be two times larger than Join Timer; the default is 600 milliseconds.

This command sets the AAM's leave period timer for GVRP in milliseconds.

Switches join VLANs by making a declaration. Declarations are withdrawn by issuing a Leave message. GARP timers set declaration timeout values.

The following example sets the Leave Timer to 800 milliseconds.

**Figure 133** GARP Timer Leave Command Example

```
ras> switch garptimer leave 800
```

### 28.8.4 GARP Timer Leaveall Command

Syntax:

```
ras> switch garptimer leaveall <leaveall msec>
```

where

`<leaveall msec>` = This sets the duration of the Leave All Period timer for GVRP in milliseconds. Each port has a single Leave All Period timer. Leave All Timer must be larger than Leave Timer; the default is 10000 milliseconds.

This command sets the AAM's leave all period timer for GVRP in milliseconds.

Switches join VLANs by making a declaration. A declaration is made by issuing a Join message using GARP. A Leave All message terminates all registrations. GARP timers set declaration timeout values.

The following example sets the Leave All Timer to 11000 milliseconds.

**Figure 134** GARP Timer Leaveall Command Example

```
ras> switch garptimer leaveall 11000
```

## 28.8.5 VLAN Port Show Command

Syntax:

```
switch vlan portshow [portlist]
```

where

`[portlist]` = You can specify a single port `<1>`, all ports `<*>` or a list of ports `<1,3,enet1>`. You can also include a range of ports `<1,5,6~10,enet1,enet2>`.

This command displays the port's VLAN settings.

The following example shows the settings for ADSL port 1.

**Figure 135** VLAN Port Show Command Example

```
ras> switch vlan portshow 1
port pvid priority frametype gvrp
-----
  1   1         0         all
```

## 28.8.6 VLAN PVID Command

Syntax:

```
switch vlan pvid <portlist> <pvid>
```

where

<portlist> = You can specify a single port <1>, all ports <\*> or a list of ports <1,3,enet1>. You can also include a range of ports <1,5,6~10,enet1,enet2>.

<pvid> = The VLAN ID. Valid parameter range = [1 – 4094].

This must be the VLAN ID of a VLAN that is already configured. The ports specified in this command must also be set to the fixed status in the VLAN.

This command sets a default VLAN ID for all untagged packets that come in through the specified port.

The following example sets the default VID of port 1 to 200.

**Figure 136** VLAN PVID Command Example

```
ras> switch vlan pvid 1 200
```

## 28.8.7 VLAN Set Command

Syntax:

```
switch vlan set <vid> <portlist>:<F<T|U>|X|N> [<portlist>:<F<T|U>|X|N>
...][name]
```

where

<vid> = The VLAN ID [1 – 4094].

<portlist> = You can specify a single port: <1>, all ports: <\*>, a list of ports: <1,3,enet1>, you can also include a range of ports: <1,5,6~10,enet1,enet2>.

- `<F<T|U>|` = The `<F>` stands for a fixed registrar administration control flag and registers a `<port #>` to the static VLAN table with `<vid>`.
- For a fixed port, you also have to specify `<T|U>`, the tag control flag.
- `<T>` has the device add an IEEE 802.1Q tag to frames going out through this port(s).
- `<U>` has the device send frames out through this port(s) without an IEEE 802.1Q tag.
- You cannot change a port from the fixed state to another state if the port's PVID is set to this VLAN.
- The VLAN must have at least one port set to the fixed status if the VLAN is the CPU (management) VLAN.
- `|X|N>` = This is the registrar administration control flag.
- `<X>` stands for forbidden and blocks a `<port #>` from joining the static VLAN table with `<vid>`.
- `<N>` stands for normal and confirms registration of the `<port #>` to the static VLAN table with `<vid>`.
- `[name]` = A name to identify the SVLAN entry.

This command adds or modifies an entry in the static VLAN table. Use the `switch vlan show` command to display your configuration. An example of a configuration is shown next.

### 28.8.7.1 Modify a Static VLAN Table Example

The following is an example of how to modify a static VLAN table.

**Figure 137** Modifying the Static VLAN Example

```
ras> switch vlan set 2000 1:FU
ras> switch vlan set 2001 2:FU
```

### 28.8.7.2 Forwarding Process Example

#### 28.8.7.2.1 Tagged Frames

- 1 First the AAM checks the VLAN ID (VID) of tagged frames or assigns temporary VIDs to untagged frames (see [Section 28.8.6 on page 231](#)).
- 2 The AAM then checks the VID in a frame's tag against the SVLAN table.

- 3 The AAM notes what the SVLAN table says (that is, the SVLAN tells the AAM whether or not to forward a frame and if the forwarded frames should have a tag).
- 4 Then the AAM applies the port filter to finish the forwarding decision. This means that frames may be dropped even if the SVLAN says to forward them. Frames might also be dropped if they are sent to a CPE (customer premises equipment) DSL device that does not accept tagged frames.

#### 28.8.7.2.2 Untagged Frames

- 1 An untagged frame comes in from the LAN.
- 2 The AAM checks the PVID table and assigns a temporary VID.
- 3 The AAM ignores the port from which the frame came, because the AAM does not send a frame to the port from which it came. The AAM also does not forward frames to “forbidden” ports.
- 4 If after looking at the SVLAN, the AAM does not have any ports to which it will send the frame, it won't check the port filter.

### 28.8.8 VLAN Frame Type Command

Syntax:

```
switch vlan frametype <portlist> <all|tag|untag>
```

where

<portlist> = You can specify a single DSL port <1>, all DSL ports <\*> or a list of DSL ports <1,3>. You can also include a range of DSL ports <1,5,6~10>.

<all|tag|untag> = Use tag to have the specified port(s) accept only incoming Ethernet frames that have a VLAN tag.

Use untag to have the specified port(s) accept only incoming Ethernet frames that do not have a VLAN tag.

Use all to have the specified port(s) accept both tagged and untagged incoming Ethernet frames.

This command sets the specified DSL ports to accept VLAN tagged Ethernet frames, untagged Ethernet frames or both.

**Note:** The AAM accepts both tagged and untagged incoming frames on the Ethernet ports.

The following example sets the AAM to accept only VLAN tagged Ethernet frames on DSL port 3.

**Figure 138** VLAN Frame Type Command Example

```
ras> switch vlan frametype 3 tag
```

## 28.8.9 VLAN CPU Show Command

Syntax:

```
switch vlan cpu show
```

This command displays the management VLAN (CPU). You can only use ports that are members of this management VLAN in order to manage the AAM.

## 28.8.10 VLAN CPU Set Command

Syntax:

```
switch vlan cpu set <vid>
```

where

<vid> = The VLAN ID. Valid parameter range = [1 – 4094].

This must be the VLAN ID of a VLAN that is already configured. The VLAN must also have at least one port set to the fixed status.

This command sets the management VLAN (CPU). You can only manage the AAM through ports that are members of the management VLAN.

**Note:** By default, you can access the management VLAN from all the Ethernet and ADSL ports since they are all in the management VLAN). If you need more security, please see the following example.

## 28.8.11 Configuring Management VLAN Example

**Note:** After the following example configuration, you must connect to the first Ethernet port through a VLAN aware device that is using the proper VLAN ID in order to perform management.

By default, the AAM's ADSL ports are members of the management VLAN (VID 1). The following procedure shows you how to configure a tagged VLAN that limits management access to just one Ethernet port.

**Note:** Use the console port to configure the AAM if you misconfigure the management VLAN and lock yourself out.

- 1 Use the `switch vlan set` command to configure a VLAN ID (VID 3 in this example) for managing the AAM (the “management” or “CPU” VLAN).

**Figure 139** CPU VLAN Configuration and Activation Example

```
ras> switch vlan set 3 enet1:FT
```

- 2 Use the `switch vlan cpu` command to set VID 3 as the management VLAN.

**Figure 140** Deleting Default VLAN Example

```
ras> switch vlan cpu set 3
```

## 28.8.12 VLAN Priority Command

Syntax:

```
switch vlan priority <portlist> <priority>
```

where

- |                               |   |  |
|-------------------------------|---|--|
| <code>&lt;portlist&gt;</code> | = | You can specify a single port: <code>&lt;1&gt;</code> , all ports: <code>&lt;*&gt;</code> , a list of ports: <code>&lt;1,3,enet1&gt;</code> , you can also include a range of ports: <code>&lt;1,5,6~10,enet1,enet2&gt;</code> . |
| <code>&lt;priority&gt;</code> | = | This is the priority value (0 to 7) to use for incoming frames with an IEEE 802.1Q VLAN tag.   |

This command sets the priority of incoming frames with an IEEE 802.1Q VLAN tag.

The following example sets a priority of three for frames (with an IEEE 802.1Q VLAN tag) that come in on ADSL port 2.

**Figure 141** VLAN Priority Command Example

```
ras> switch vlan priority 2 3
```

## 28.8.13 VLAN Delete Command

Syntax:

```
switch vlan delete <vlanlist>
```

where

<vlanlist> = You can specify a single VID: <1>, all VID: <\*>, a list of VID: <1,3>, you can also include a range of VID: <1,5,6~10>.

You cannot delete a VLAN if any PVIDs are set to use the VLAN or the VLAN is the CPU (management) VLAN.

This command deletes the specified VLAN ID entry from the static VLAN table

The following example deletes entry 2 in the static VLAN table.

**Figure 142** VLAN Delete Command Example

```
ras> switch vlan delete 2
```

## 28.9 VLAN Enable

Syntax:

```
switch vlan <vid>
```

This command enables the specified VLAN ID in the SVLAN (Static VLAN) table.

## 28.10 VLAN Disable

Syntax:

```
switch vlan disable <vid>
```

This command disables the specified VLAN ID in the SVLAN (Static VLAN) table. You cannot disable a VLAN if any PVIDs are set to use the VLAN or the VLAN is the CPU (management) VLAN.

### 28.10.1 VLAN Show Command

Syntax:

```
switch vlan show <vlanlist>
```

where

<vlanlist> = You can specify a single VID: <1>, all VID: <\*>, a list of VID: <1,3>, you can also include a range of VID: <1,5,6~10>.

This command shows information about the specified port's VLAN settings.

The following example shows the settings for all VLANs.

**Figure 143** VLAN Show Command Example

```

ras> switch vlan show *
vid name                F:fixed X:forbidden N:normal  U:untag T:tag
-----
  1  DEFAULT
     enabled             123456789012 12
                        FFFFFFFFFFFF FF
                        UUUUUUUUUUUU UU

  2  test2
     enabled             123456789012 12
                        FXXXXXXXXXXX NN
                        U----- TT

  3  test3
     enabled             123456789012 12
                        FXXXXXXXXXXX NN
                        U----- TT

200  test200
     enabled             123456789012 12
                        XXXXXXXXXXXX FN
                        ----- UT

```

## 28.11 MAC Filter Commands

Use the MAC filter commands to allow only incoming frames from MAC (Media Access Control) address(es) that you specify. MAC filter commands are listed next. You may specify up to ten MAC addresses per port.

### 28.11.1 MAC Filter Show Command

Syntax:

```
switch mac filter show [portlist]
```

where

[portlist] = You can specify a single ADSL port <1>, all ADSL ports <\*> or a list of ADSL ports <1,3,5>. You can also include a range of ports <1,5,6~10>.

This command displays the MAC filtering status (V for enabled, - for disabled) and the fixed source MAC addresses on the specified ADSL port(s) or on all ADSL ports if no port is specified.

The following example displays the MAC filtering status and the fixed source MAC addresses on ADSL port 5.

**Figure 144** MAC Filter Show Command Example

```
ras> switch mac filter show 5
      status:V, only listed MACs can pass through this port.
      status:-, every MAC can pass this port.
port status mac
-----
 5      V      00:00:00:00:00:29
           00:00:00:00:00:2a
           00:00:00:00:00:2b
           00:00:00:00:00:2c
           00:00:00:00:00:2d
           00:00:00:00:00:2e
           00:00:00:00:00:2f
           00:00:00:00:00:30
           00:00:00:00:00:31
           00:00:00:00:00:32
```

## 28.11.2 MAC Filter Enable Command

Syntax:

```
switch mac filter enable <portlist>
```

where

<portlist> = You can specify a single ADSL port <1>, all ADSL ports <\*> or a list of ADSL ports <1,3,5>. You can also include a range of ports <1,5,6~10>.

This command turns on the MAC filtering feature on the specified ADSL port(s) or on all ADSL ports if no port is specified.

The following example turns on the MAC filtering feature on ADSL port 5.

**Figure 145** MAC Filter Enable Command Example

```
ras> switch mac filter enable 5
```

## 28.11.3 MAC Filter Disable Command

Syntax:

```
switch mac filter disable <portlist>
```

where

[portlist] = You can specify a single ADSL port <1>, all ADSL ports <\*> or a list of ADSL ports <1,3,5>. You can also include a range of ports <1,5,6~10>.

This command turns off the MAC filtering feature on the specified ADSL port(s) or on all ADSL ports if no port is specified.

The following example turns off the MAC filtering feature on ADSL port 5.

**Figure 146** MAC Filter Disable Command Example

```
ras> switch mac filter disable 5
```

## 28.11.4 MAC Filter Set Command

Syntax:

```
switch mac filter set <port> <mac> [<mac> <mac> ...]
```

where

<port> = The number of an ADSL port.  
 <mac> = The source MAC address in "00:a0:c5:12:34:56" format.

This command adds an allowed source MAC address on the specified ADSL port.

The following example adds source MAC address 00:a0:c5:12:34:56 for ADSL port 5.

**Figure 147** MAC Filter Set Command Example

```
ras> switch mac filter set 5 00:a0:c5:12:34:56
```

## 28.11.5 MAC Filter Delete Command

Syntax:

```
switch mac filter delete <port> <mac> [<mac> <mac> ...]
```

where

<port> = The number of an ADSL port.  
 <mac> = The source MAC address in "00:a0:c5:12:34:56" format.

This command removes a configured source MAC address from the ADSL port that you specify.

The following example removes the source MAC address of 00:a0:c5:12:34:56 from the MAC filter for ADSL port 5.

**Figure 148** MAC Filter Delete Command Example

```
ras> switch mac filter delete 5 00:a0:c5:12:34:56
```

## 28.12 MAC Count Commands

Use MAC count commands to limit how many MAC addresses may be dynamically learned or statically configured on an ADSL port. MAC count commands are listed next.

### 28.12.1 MAC Count Show Command

Syntax:

```
switch mac count show [portlist]
```

where

[portlist] = You can specify a single ADSL port <1>, all ADSL ports <\*> or a list of ADSL ports <1,3,5>. You can also include a range of ports <1,5,6~10>.

This command displays the MAC count settings on the specified ADSL port(s) or on all ADSL ports if no port is specified.

The following example displays the MAC count settings for ADSL port 4.

**Figure 149** MAC Count Show Command Example

```
ras> switch mac count show 4
port status count
-----
 4      V      1024
```

### 28.12.2 MAC Count Enable Command

Syntax:

```
switch mac count enable <portlist>
```

where

<portlist> = You can specify a single ADSL port <1>, all ADSL ports <\*> or a list of ADSL ports <1,3,5>. You can also include a range of ports <1,5,6~10>.

This command enables the MAC count filter on the specified ADSL port(s). You can only enable the MAC count filter on ADSL ports that do not have the MAC filter enabled.

The following example turns on the MAC count filter on ADSL port 4.

**Figure 150** MAC Count Enable Command Example

```
ras> switch mac count enable 4
```

### 28.12.3 MAC Count Disable Command

Syntax:

```
switch mac count disable <portlist>
```

where

<portlist> = You can specify a single ADSL port <1>, all ADSL ports <\*> or a list of ADSL ports <1,3,5>. You can also include a range of ports <1,5,6~10>.

This command disables the MAC filtering feature on the specified ADSL port(s).

The following example turns off the MAC count filter on ADSL port 4.

**Figure 151** MAC Count Disable Command Example

```
ras> switch mac count disable 4
```

### 28.12.4 MAC Count Set Command

Syntax:

```
switch mac count set <portlist> <count>
```

where

- <portlist> = You can specify a single ADSL port <1>, all ADSL ports <\*> or a list of ADSL ports <1,3,5>. You can also include a range of ports <1,5,6~10>.
- <count> = Set the limit for how many MAC addresses that a port may dynamically learn. For example, if you are configuring port 2 and you set this field to "5", then only five devices with dynamically learned MAC addresses may access port 2 at any one time. A sixth device would have to wait until one of the five learned MAC addresses ages out.

The valid range is from "1" to "1024".

This command sets the limit for how many MAC addresses may be dynamically learned on the specified ADSL port(s).

**Note:** If you also use MAC filtering on a port, it is recommended that you set the MAC count to be equal to or greater than the number of MAC filter entries you configure.

The following example sets the MAC count filter to allow up to 50 MAC addresses to be dynamically learned on ADSL port 7.

**Figure 152** MAC Count Set Command Example

```
ras> switch mac count set 7 50
```

## 28.13 Packet Filter Commands

Use the following packet filter commands to filter out specific types of packets on specific ports.

### 28.13.1 Packet Filter Show Command

Syntax:

```
switch pktfilter show [portlist]
```

where

- [portlist] = You can specify a single ADSL port <1>, all ADSL ports <\*> or a list of ADSL ports <1,3,5>. You can also include a range of ports <1,5,6~10>.

This command displays the packet type filter settings on the specified ADSL port(s) or on all ADSL ports if no port is specified.

The following example displays the packet type filter settings for ADSL port 9. A “V” in a column means that the port is set to allow that type of packets to pass through.

**Figure 153** Packet Filter Show Command Example

```

ras> switch pktfilter show 9
V: pass through, -: filter out
port pppoe ip arp netbios dhcp eapol igmp
-----
   9   V   -   V       -       -       -       V

```

## 28.13.2 Packet Filter Set Command

Syntax:

```

switch pktfilter set <portlist>
[pppoe|ip|arp|netbios|dhcp|eapol|igmp|none]

```

where

<portlist> = You can specify a single ADSL port <1>, all ADSL ports <\*> or a list of ADSL ports <1,3,5>. You can also include a range of ports <1,5,6~10>.

[pppoe|ip|arp|netbios|dhcp|eapol|igmp|none] = [pppoe] Reject PPPoE packets. (Point-to-Point Protocol over Ethernet) relies on PPP and Ethernet. PPPoE is a specification for connecting the users on an Ethernet to the Internet through a common broadband medium, such as a single DSL line, wireless device or cable modem.

[ip] Reject IP packets. Internet Protocol. The underlying protocol for routing packets on the Internet and other TCP/IP-based networks.

[arp] Reject ARP packets. Address Resolution Protocol is a protocol for mapping an Internet Protocol address (IP address) to a physical computer address that is recognized in the local network.

[netbios] Reject NetBIOS packets. (Network Basic Input/Output System) are TCP or UDP broadcast packets that enable a computer to connect to and communicate with a LAN.

[dhcp] Reject DHCP packets. Dynamic Host Configuration Protocol automatically assigns IP addresses to clients when they log on. DHCP centralizes IP address management on central computers that run the DHCP server program. DHCP leases addresses, for a period of time, which means that past addresses are “recycled” and made available for future reassignment to other systems.

[eapol] Reject EAPoL packets. EAP (Extensible Authentication Protocol, RFC 2486) over LAN. EAP is used with IEEE 802.1x to allow additional authentication methods (besides RADIUS) to be deployed with no changes to the access point or the wireless clients.

[igmp] Reject IGMP packets. Internet Group Multicast Protocol is used when sending packets to a specific group of hosts.

[none] Accept all packets.

This command sets the packet type filter for the specified ADSL port(s).

The following example sets ADSL port 9 to reject ARP, PPPoE and IGMP packets.

**Figure 154** Packet Filter Set Command Example

```
ras> switch pktfilter set 9 arp pppoe igmp
```

# CHAPTER 29

## IP Commands

This chapter shows you how to use the `ip` commands to configure the IP (Internet Protocol) parameters.

### 29.1 IP Commands Introduction

Use the AAM's management IP addresses to manage it through the network.

### 29.2 IP Settings and Default Gateway

Use the following command sequence to set the AAM's IP settings for the Ethernet 1 and 2, and DSL ports, VID and default gateway. With the Ethernet 1 and 2, and DSL ports, you must connect to the AAM through a port that is a member of the management (CPU) VLAN in order to perform in-band management.

```
1 ras> ip set <new ip address> [</netmask>]
2 ras> ip gateway <ip>
3 ras> config save
```

where

<code>&lt;new ip address&gt;</code>	=	The IP address you want to configure for the AAM.
<code>&lt;/netmask&gt;</code>	=	The bit number of the subnet mask of the IP address you want to configure for AAM's uplink, downlink and AAM DSL ports. To find the bit number, convert the subnet mask to binary and add all of the 1's together. Take "255.255.255.0" for example. 255 converts to eight 1's in binary. There are three 255's, so add three eights together and you get the bit number (24).
<code>&lt;ip&gt;</code>	=	The default gateway IP address you want to configure for the AAM.

Line 1 changes the IP settings for the AAM's uplink, downlink and AAM DSL ports. If you don't enter the subnet mask, the system automatically computes the subnet mask.

Line 2 changes the default gateway (next hop). This tells the AAM where to send packets that have a destination IP address that is not on the same subnet as the AAM's IP address.

Line 3 saves the new configuration to the nonvolatile memory.

For example, use the following command sequence sets the AAM to have 192.168.1.3 as the IP address, 255.255.255.0 for the subnet mask and 192.168.1.233 for the default gateway.

```

ras> ip set 192.168.1.3/24
ras> ip gateway 192.168.1.233
ras> config save

```

**Figure 155** IP Settings and Default Gateway Address



The AAM leaves the factory with a default (in-band) management IP address of 192.168.1.1 and a subnet mask of 255.255.255.0, (ff:ff:ff:00 in hexadecimal notation), and the default gateway set at 192.168.1.254. Make sure that you configure the IP parameters correctly before you connect an AAM to the network, otherwise, you may interrupt services already running.

## 29.3 IP Commands Summary

The following table lists the `ip` commands you can use with the AAM.

**Table 62** IP Commands

COMMAND			DESCRIPTION
<code>ip</code>			
	<code>show</code>		Displays the management IP address settings.
	<code>arp</code>		
		<code>show</code>	Displays the device's IP Address Resolution Protocol status.
		<code>flush</code>	Clears the device's IP Address Resolution Protocol status.
	<code>set</code>	<code>&lt;ip&gt;[/netmask]</code>	Sets the management IP address and subnet mask.
	<code>gateway</code>	<code>&lt;gateway ip&gt;</code>	Sets the IP address of the device's default gateway.
	<code>route</code>		
		<code>show</code>	Displays the routing table.
		<code>set</code>	<code>&lt;dst ip&gt;[/netmask]</code> <code>&lt;gateway ip&gt;</code> <code>[metric] &lt;name&gt;</code>

**Table 62** IP Commands (continued)

COMMAND				DESCRIPTION
			default <gateway ip> <metric>	Sets the AAM's default route.
		delete	<dst ip>[/ netmask]	Removes a routing table entry.
		flush		Clears the routing table.
	ping	<ip> [count]		Pings a remote host.
	showall	[nopause]		Displays all IP configuration.

## 29.4 General IP Commands

The following shows general IP commands that help with the management of the IP parameters.

### 29.4.1 Show Command

Syntax:

```
ras> ip show
```

Use the command to display the current management IP settings.

### 29.4.2 Ping Command

Syntax:

```
ras> ip ping <ip> [count]
```

where

<ip> = The IP address of the target.

[count] = The number of pings you want the AAM to send

This is an IP facility to check for network functionality by sending an echo request to another IP host and waiting for the reply.

### 29.4.3 Route Set Command

Syntax:

```
ras> ip route set <dst ip>[/netmask] <gateway ip> [metric] <name>
```

or

```
ras> ip route set default <gateway ip> <metric>
```

where

<dst ip>	=	The destination IP address of packets that this static route is to route.
[/netmask]	=	The destination subnet mask of packets that this static route is to route.
<gateway ip>	=	The IP address of the gateway that you want to send the packets through.
[metric]	=	The metric (hop count) of this static route.
<name>	=	A name to identify this static route. Up to 31 ASCII characters. Spaces and tabs are not allowed.
default	=	Use this to configure the AAM's default route.

This command defines a new, static IP forwarding route or edits an existing one.

## 29.4.4 Route Delete Command

Syntax:

```
ras> ip route delete <dst ip>[/netmask]
```

where

<dst ip>	=	The destination IP address of packets to which this static route applies.
[/netmask]	=	The destination subnet mask of packets to which this static route applies.

This command removes a static, IP forwarding route.

## 29.4.5 Route Show Command

Syntax:

```
ras> ip route show
```

This command displays the AAM's routing table.

An example is shown next.

**Figure 156** Route Show Command Example

```

ras> ip route show
index dest          gateway          metric name
-----
1     192.168.1.0/24    192.168.1.1     1
2     default           192.168.1.254   1

```

## 29.4.6 ARP Show Command

Syntax:

```
ras> ip arp show
```

This command displays the AAM's IP Address Resolution Protocol table. This is the list of IP addresses and matching MAC addresses that the AAM has resolved.

An example is shown next.

**Figure 157** ARP Show Command Example

```

ras> ip arp show
ip          mac address
-----
172.23.14.254 00:0c:db:30:ac:00
172.23.15.254 00:0c:db:30:ac:00

```

## 29.4.7 ARP Flush Command

Syntax:

```
ras> ip arp flush
```

This command clears the AAM's IP Address Resolution Protocol table.



# CHAPTER 30

## Statistics Commands

This chapter describes the `statistics` commands.

### 30.1 Statistics Commands Summary

The following table lists the `statistics` commands you can use with the AAM.

**Table 63** Statistics Commands

COMMAND				DESCRIPTION
<code>statistics</code>				
	<code>monitor</code>			Displays hardware monitor statistics.
	<code>adsl</code>			
		<code>show</code>	[ <code>portlist</code> ]	Displays ADSL port connection statistics.
		<code>linedata</code>	< <code>portlist</code> >	Displays the line data load per symbol (tone).
		<code>lineinfo</code>	< <code>portlist</code> >	Displays the statistics of the specified ADSL ports.
		<code>lineperf</code>	< <code>portlist</code> >	Displays the line quality of the specified ADSL port.
		<code>linerate</code>	< <code>portlist</code> >	Displays the line rate.
		<code>15mperf</code>	< <code>portlist</code> > [ <code>count</code> <0..96>]	Displays line performance statistics for the current and previous 15-minute periods.
		<code>1dayperf</code>	< <code>portlist</code> >	Displays line performance statistics for the current and previous 24 hours.
	<code>igmpsnoop</code>			Displays IGMP snooping statistics.
	<code>rstp</code>			Displays RSTP statistics.
	<code>vlan</code>	[ <code>vlanlist</code> ]		Displays current VLANs.
	<code>mac</code>			Displays the current MAC address forwarding table.
	<code>port</code>	< <code>portlist</code> > [< <code>vpi</code> > < <code>vci</code> > [ <code>clear</code> ]		This command displays and/or erases port statistics.
	<code>dot1x</code>	[ <code>portlist</code> ]		Displays IEEE 802.1X statistics.
	<code>enet</code>			Displays Ethernet port settings and statistics.

**Table 63** Statistics Commands (continued)

COMMAND				DESCRIPTION
	ip			Displays a management port's status and performance data.
	showall	[nopause]		Displays all statistics configuration.

## 30.2 Statistics Monitor Command

Syntax:

```
ras> statistics monitor
```

This command shows the current hardware status (voltage, temperature, fan speed and alarm status).

An example is shown next.

**Figure 158** Statistics Monitor Command Example

```

ras> statistics monitor
Hardware monitor status: enabled
      nominal limit(hi) limit(lo)  current   min     max     avg status
-----
v1(v)  1.200    1.344    1.056    1.165   1.152   1.165   1.155 Normal
v2(v)  1.800    1.944    1.656    1.806   1.806   1.806   1.806 Normal
v3(v)  3.300    3.564    3.036    3.200   3.200   3.257   3.200 Normal
v4(v) 18.000   19.440   16.560   18.175  18.175  19.028  18.175
Normal

      limit(hi) limit(lo)  current   min     max     avg status
-----
t1(c)  97.000   -55.000   33.000   28.000  33.000  30.000 Normal
t2(c)  97.000   -55.000   39.000   29.000  39.000  36.000 Normal
t3(c)  97.000   -55.000   38.000   30.000  38.000  35.000 Normal

ras>

```

## 30.3 Statistics Port Command

Syntax:

```
ras> statistics port <portlist> [<vpi> <vci>] [clear]
```

where

<code>&lt;portlist&gt;</code>	=	You can specify a single port <code>&lt;1&gt;</code> , all ports <code>&lt;*&gt;</code> or a list of ports <code>&lt;1,3,enet1&gt;</code> . You can also include a range of ports <code>&lt;1,5,6~10,enet1,enet2&gt;</code> .
<code>&lt;vpi&gt; &lt;vci&gt;</code>	=	The VPI and VCI of an individual PVC.
<code>[clear]</code>		Use <code>clear</code> to have the AAM set the specified port(s) or PVC's counters back to zero.

This command displays and/or erases port statistics.

The following example displays port statistics for ADSL port 1.

**Figure 159** Statistics Port Command Example

```

ras> statistics port 1
[adsl port 1]
tx packets          : 20
rx packets          : 0
tx uni-packets      : 1
rx uni-packets      : 0
tx nonuni-packets   : 19
rx nonuni-packets   : 0
tx discard packets  : 0
rx discard packets  : 0
errors              : 0
tx rate (bytes/s)   : 0
rx rate (bytes/s)   : 128
tx bytes            : 5904
rx bytes            : 0

```

where

<code>tx uni-packets</code>	=	This field shows the number of unicast packets transmitted on this port.
<code>rx uni-packets</code>	=	This field shows the number of unicast packets received on this port.
<code>tx nonuni-packets</code>	=	This field shows the number of non-unicast (broadcast and multicast) packets transmitted on this port.
<code>rx nonuni-packets</code>	=	This field shows the number of non-unicast (broadcast and multicast) packets received on this port

See the web configurator sections on port statistics for details on the other port statistics fields.

## 30.4 Statistics ADSL Commands

Use these commands to display ADSL port statistics.

### 30.4.1 Statistics ADSL Show Command

Syntax:

```
statistics adsl show [portlist]
```

where

[portlist] = You can specify a single ADSL port <1>, all ADSL ports <\*> or a list of ADSL ports <1,3,5>. You can also include a range of ports <1,5,6~10>.

This command displays ADSL port connection statistics including the status (V for enabled, - for disabled), ADSL operational mode, upstream and downstream maximum rates, up time and the number of errored seconds.

The following example displays connection statistics for ADSL port 3.

**Figure 160** ADSL Show Command Example

```
ras> statistics adsl show 3
port status mode      up/downstream      up time error second
-----
  3   -   -           -/ -           -           -
```

### 30.4.2 Statistics ADSL Linedata Command

Syntax:

```
statistics adsl linedata <portlist>
```

where

<portlist> = You can specify a single ADSL port <1>, all ADSL ports <\*> or a list of ADSL ports <1,3,5>. You can also include a range of ports <1,5,6~10>.

This command shows the line bit allocation of an ADSL port.

Discrete Multi-Tone (DMT) modulation divides up a line's bandwidth into tones. This command displays the number of bits transmitted for each tone. This can be used to determine the quality of the connection, whether a given sub-carrier loop has sufficient margins to support ADSL transmission rates, and possibly to determine whether certain specific types of interference or line attenuation exist. Refer to the ITU-T G.992.1 recommendation for more information on DMT.

The better (or shorter) the line, the higher the number of bits transmitted for a DMT tone. The maximum number of bits that can be transmitted per DMT tone is 15.

“upstream carrier load” displays the number of bits transmitted per DMT tone for the upstream channel (from the subscriber's DSL modem or router to the AAM).

“downstream carrier load” displays the number of bits received per DMT tone for the downstream channel (from the AAM to the subscriber's DSL modem or router).

The bit allocation contents are only valid when the link is up.

In the following example, the upstream channel is carried on tones 7 to 39 and the downstream channel is carried on tones 53 to 259 (space is left between the channels to avoid interference).

**Figure 161** Linedata Command Example

```

ras> statistics adsl linedata 1
[port 1]
up stream carrier load: number of bits per symbol(tone):
tone   0- 19: 00 00 00 00 00 00 02 03 04 05 - 06 07 07 07 07 07 07 08 08
tone  20- 39: 08 08 07 08 08 07 07 06 06 05 - 04 03

down stream carrier load: number of bits per symbol(tone):
tone   0- 19: 00 00 00 00 00 00 00 00 00 00 - 00 00 00 00 00 00 00 00 00
tone  20- 39: 00 00 00 00 00 00 00 00 00 00 - 00 00 00 00 00 00 00 00 00
tone  40- 59: 00 00 00 00 00 00 00 00 00 00 - 00 00 00 01 01 01 01 01 02
tone  60- 79: 02 02 02 02 00 02 02 02 02 02 - 02 02 02 02 02 02 02 02 02
tone  80- 99: 02 02 02 02 02 02 02 02 02 02 - 02 02 02 02 02 02 02 02 02
tone 100-119: 02 02 02 02 02 02 02 02 02 02 - 02 02 02 02 02 02 02 02 02
tone 120-139: 02 02 02 02 02 02 02 02 02 02 - 02 02 02 02 02 02 02 02 02
tone 140-159: 02 02 02 02 02 02 02 02 02 02 - 02 02 02 02 02 02 02 02 02
tone 160-179: 02 02 02 02 02 02 02 02 02 02 - 02 02 02 02 02 02 02 02 02
tone 180-199: 02 02 02 02 02 02 02 02 02 02 - 02 02 02 02 02 02 02 02 02
tone 200-219: 02 02 02 02 02 02 02 02 02 02 - 02 02 02 02 02 02 02 02 02
tone 220-239: 02 02 02 02 02 02 02 02 02 02 - 02 02 02 02 02 02 02 02 02
tone 240-259: 02 02 02 02 02 02 02 02 02 02 - 02 02 02 02 02 02

```

### 30.4.3 Statistics ADSL Lineinfo Command

Syntax:

```
statistics adsl lineinfo <portlist>
```

where

<portlist> = You can specify a single ADSL port <1>, all ADSL ports <\*> or a list of ADSL ports <1,3,5>. You can also include a range of ports <1,5,6~10>.

This command shows the line operating values of an ADSL port.

An example is shown next.

**Figure 162** Lineinfo Command Example

```
ras> st ad linei 1
[port 1]
operating modes:
- service type in operation: adsl2+
- TRELLIS operation mode   : on
connection detail:
- down/up stream interleaved delay (ms): 3/ 2
- total transceiver output power  (dbm): -7

atuc information:
- vendor id:      00000000000000000000000000000000
- version number: 00000000000000000000000000000000
- serial number :
000000000000000000000000000000000000000000000000000
00
atur information:
- vendor id:      b5004244434d00000000000000000000
- version number: 00000000000000000000000000000000
- serial number :
000000000000000000000000000000000000000000000000000
```

The service type in operation is the ADSL standard that the port is using.

Trellis coding helps to reduce the noise in ADSL transmissions. Trellis may reduce throughput but it makes the connection more stable.<sup>2</sup>

The numbers of milliseconds of interleave delay for downstream and upstream transmissions are listed. The total output power of the transceiver varies with the length and line quality. The farther away the subscriber's ADSL modem or router is or the more interference there is on the line, the higher the power will be.

Information obtained prior to training to steady state transition will not be valid or will be old information. Annex A refers to POTS.

The `atuc information` fields show data acquired from the ATUC (ADSL Termination Unit – Central), in this case AAM, during negotiation/provisioning message interchanges.

---

2. At the time of writing, the AAM always uses Trellis coding.

The `atur` information fields show data acquired from the ATUR (ADSL Termination Unit – Remote), in this case the subscriber's ADSL modem or router, during negotiation/provisioning message interchanges. This information can help in identifying the subscriber's ADSL modem or router.

The vendor ID, vendor version number and product serial number are obtained from vendor ID fields (see ITU-T G.994.1) or R-MSG51 (see T1.413).

### 30.4.4 ADSL Lineperf Command

Syntax:

```
statistics adsl lineperf <portlist>
```

where

`<portlist>` = You can specify a single ADSL port `<1>`, all ADSL ports `<*>` or a list of ADSL ports `<1,3,5>`. You can also include a range of ports `<1,5,6~10>`.

This command shows the line performance counters of an ADSL port.

An example is shown next.

**Figure 163** Lineperf Command Example

```

ras> statistics adsl lineperf 1
[port 1] Perf since boot up
nfebe-I/nfebe-ni :      0/      0 (Far End CRC)
ncrc-I/ncrc-ni   :      0/      0 (Near End CRC)
nfecc-I/nfecc-ni : 4524/      0 (Far End Corrected FEC)
nfec-I/nfec-ni   :      0/      0 (Near End Corrected FEC)
nblks-ds/nblks-us:      0/      0
init-ds/init-us  :      2/      2
n-es-ds/n-es-us  :      46/    150
n-ses-ds/n-ses-us:      46/     43
n-uas-ds/n-uas-us:      36/     36
n-lpr-ds/n-lpr-us:      -/      0

```

These counters display line performance data that has been accumulated since the system started. The definitions of near end/far end are relative to the ATU-C (ADSL Termination Unit-Central Office). Downstream (ds) refers to data from the ATU-C and upstream (us) refers to data from the ATU-R. “I” stands for interleaved and “ni” stands for non-interleaved (fast mode).

A block is a set of consecutive bits associated with the path; each bit belongs to one and only one block. Consecutive bits may not be contiguous in time.

**Table 64** Line Performance Counters

LABEL	DESCRIPTION
nfebe	The Number of Far End Block Errors.
ncrc	Near end Cyclic Redundancy Checks.
nfecc	The Far End Corrected blocks.
nfec	The Near End Corrected blocks.
nblks	The Number of Blocks transmitted.
init	The number of link ups and link downs.
n-es	The Number of Errored Seconds. This is how many seconds contained at least one errored block or at least one defect.
n-ses	The Number of Severely Errored Seconds. This is how many seconds contained 30% or more errored blocks or at least one defect. This is a subset of n-es.
n-uas	The Number of Unavailable Seconds.
n-lpr	The Number of times a Loss of PowerR (on the ATUR) has occurred.

### 30.4.5 ADSL 15 Minute Performance Command

Syntax:

```
statistics adsl 15mperf <portlist> [count <0..96>]
```

where

- <portlist> = You can specify a single ADSL port <1>, all ADSL ports <\*> or a list of ADSL ports <1,3,5>. You can also include a range of ports <1,5,6~10>.
- [count <0..96>] = Specify for which 15-minute interval (0~96) you want to display performance statistics. 0 is the current 15 minutes.

This command displays line performance statistics for the current and previous 15-minute periods.

An example is shown next.

**Figure 164** ADSL 15 Minute Performance Command Example

```

ras> st ad 15mperf 1
Port 1 Current 15 Min elapsed time:135 sec (Link Up)
  Current 15 Min PM:      ATUC      ATUR
    lofs:                 0         0
    loss:                 0         0
    lols:                 0         -
    lprs:                 -         0
    eSs:                  0         3
    inits:                0         -
    sesl:                 0         0
    uasl:                 0         0
  History 15 Min PM-1:   ATUC      ATUR
    lofs:                 0         0
    loss:                 0         0
    lols:                 0         -
    lprs:                 -         0
    eSs:                  0        40
    inits:                0         -
    sesl:                 0         0
    uasl:                 0         0
  History 15 Min PM-2:   ATUC      ATUR
    lofs:                 7         7
    loss:                28        18
    lols:                18         -
    lprs:                 -         0
    eSs:                 28        58
    inits:                1         -
    sesl:                 28        25
    uasl:                 18        18

```

The following table explains these counters.

**Table 65** ADSL 15 Minute Performance Counters

LABEL	DESCRIPTION
atuc	Upstream. These statistics are for the connection (or traffic) coming from the subscriber's device to the AAM.
atur	Downstream. These statistics are for the connection (or traffic) going from the AAM to the subscriber's device.
lofs	The number of Loss Of Frame Seconds that have occurred within the 15-minute period.
loss	The number of Loss Of Signal Seconds that have occurred within the 15-minute period.
lols	The number of Loss Of Link Seconds that have occurred within the 15-minute period.
lprs	The Number of times a Loss of Power (on the ATUR) has occurred within the 15-minute period.
eSs	The number of Errored SecondS that have occurred within the 15-minute period.
inits	The number of initialization failure traps that have occurred within the 15-minute period.

**Table 65** ADSL 15 Minute Performance Counters

LABEL	DESCRIPTION
sesl	The number of Severely Errored Seconds that have occurred within the 15-minute period.
uasl	The number of UnAvailable Seconds that have occurred within the 15-minute period.

These counters are also used in the alarm profiles (see [Section 27.3.13 on page 208](#)).

### 30.4.6 ADSL 1 Day Performance Command

Syntax:

```
statistics adsl ldayperf <portlist>
```

where

<portlist> = You can specify a single ADSL port <1>, all ADSL ports <\*> or a list of ADSL ports <1,3,5>. You can also include a range of ports <1,5,6~10>.

This command displays line performance statistics for the current and previous 24 hours.

An example is shown next.

**Figure 165** ADSL 1 Day Performance Command Example

```

ras> st ad 1dayperf 1
Port 1 current 1 day elapsed time:3819 sec (Link Up)
Current 1 Day Perf      ATUC      ATUR
    lofs                7         7
    loss                46        36
    lols                18         -
    lprs                -         0
    eSs                 46       153
    inits                2         -
    sesl                46        43
    uasl                36        36

Port 1 previous 1 day elapsed time:0 sec
Previous 1 Day Perf      ATUC      ATUR
    lofs                0         0
    loss                0         0
    lols                0         -
    lprs                -         0
    eSs                 0         0
    inits                0         -
    sesl                0         0
    uasl                0         0

```

See [Table 65 on page 259](#) for details about these counters.

## 30.5 Statistics IP Command

Syntax:

```
ras> statistics ip
```

This command shows the statistics for the CPU IP traffic.

An example is shown next.

**Figure 166** Statistics IP Command Example

```

ras> statistics ip
[Ethernet]
inet      : 172.23.14.253      netmask: 0.0.0.0
broadcast: 172.23.255.255    mtu: 1500
in octet  : 10728504  in unicast :      738  in multicast   : 232488
in discard :      0  in error   :      0  in unknown proto: 0
out octet  :  41361  out unicast:    861  out multicast   : 0
out discard:      0  out error   :      0

```



# CHAPTER 31

## Config Commands

This chapter describes the `config` commands.

### 31.1 Config Commands Summary

The following table lists the `config` commands you can use with the AAM.

**Table 66** Config Commands

COMMAND			DESCRIPTION
<code>config</code>			
	<code>show</code>	<code>&lt;sys sw adsl  ip stat all &gt; [nopause]</code>	Displays the device's configuration.
	<code>save</code>		Saves the current configuration.
	<code>restore</code>		Reloads the factory default configuration.

### 31.2 Config show Command Example

Syntax:

```
ras> config show <sys|sw|adsl|ip|stat|all> [nopause]
```

This command shows the configuration of the specified category. `nopause` allows you to show all settings at one time so you do not need to press a key to continue.

An example is shown next.

**Figure 167** Config Show Command Example

```
ras> config show ip nopause
===== ip =====
===== ip/show =====
interface ip          netmask
-----
Ethernet 172.23.15.200 255.255.255.0
default gateway: 172.23.15.254

===== ip/arp =====
ip          mac address
-----
172.23.15.101 08:00:20:ad:f6:88
172.23.15.102 00:03:ba:44:fe:ec
172.23.15.172 02:0e:a6:89:41:60
172.23.15.254 00:04:80:9b:78:00

===== ip/route =====
index dest          gateway          metric name
-----
1      172.23.15.0/24    172.23.15.200    1
2      default           172.23.15.254    1
```

---

# CHAPTER 32

## Firmware and Configuration File Maintenance

This chapter tells you how to upload a new firmware and/or configuration file for the AAM.

### 32.1 Firmware and Configuration File Maintenance Overview

The AAM's built-in FTP server allows you to use any FTP client (for example, ftp.exe in Windows) to upgrade AAM or AAM firmware or configuration files. The firmware or configuration file upgrade is done during operation (run-time).

**Note:** Do not interrupt the file transfer process, as it may permanently damage your AAM.

**Note:** The AAM automatically restarts when the upgrade process is complete.

### 32.2 Filename Conventions

The configuration file (called config-0) contains the factory default settings in the menus such as password, IP address, VLANs and so on. It arrives from ZyXEL with a "dat" filename extension.

ZyNOS (ZyXEL Network Operating System sometimes referred to as the "ras" file) is the system firmware and has a "bin" filename extension. The configuration file has a "rom" filename extension. With many FTP and clients, the filenames are similar to those shown next.

```
ftp> put firmware.bin ras
```

This is a sample from a FTP session to transfer the computer file `firmware.bin` to the AAM.

```
ftp> get config-0 config.txt
```

This is a sample from a FTP session to transfer the AAM's current configuration file (including the configuration files of all the AAMs) to the computer file `config.txt`.

If your FTP client does not allow you to have a destination filename different than the source, you will need to rename them as the AAM only recognizes “config-0” and “ras”. Be sure you keep unaltered copies of the files for later use.

The following table is a summary. Please note that the internal filename refers to the filename on the AAM and the external filename refers to the filename not on the AAM, that is, on your computer, local network or FTP site and so the name (but not the extension) may vary. After uploading new firmware, use the `sys version` command to confirm that you have uploaded the correct firmware version.

**Table 67** File Name Conventions

FILE TYPE	INTERNAL NAME	EXTERNAL NAME	DESCRIPTION
Configuration File	config-0	*.dat	This is the configuration filename for the AAM.
Firmware	ras	*.bin	This is the generic name for the ZyNOS firmware on the AAM.

## 32.3 Editable Configuration File

The configuration file can be downloaded as a plain-text (ASCII) file. Edits to the configuration can be made to this file before it is uploaded again to the AAM.

**Note:** You can change the “.dat” file to a “.txt” file and still upload it to the AAM.

### 32.3.1 Editable Configuration File Backup

Configure your system, and then use FTP to backup the plain-text configuration file onto your computer. Do the following to backup the configuration file:

Use an FTP client to connect to the AAM.

```
C:\> ftp <AAM IP address>
```

Enter the User name (just press [ENTER]).

```
User: [ENTER]
```

Enter the management password (1234 by default).

```
Password: 1234
```

```
230 Logged in
```

Use `get` to transfer the configuration file to the computer. The configuration file on the system (that you want to backup to the computer) is named `config-0`.

```
ftp> get config-0
```

Quit FTP.

```
ftp> quit
```

### 32.3.2 Edit Configuration File

Open the `config-0` file via notepad (see the following example) and edit to a desired configuration.

**Note:** Ensure that any changes you make to the commands in the configuration file correspond to the commands documented in this User's Guide.

**Figure 168** Configuration File Example

```
#### sysinfo
sys info hostname ras
sys info location taiwan
sys info contact zmlin
#### snmp
sys snmp getcommunity public
sys snmp setcommunity public
sys snmp trapcommunity 1234
sys snmp trustedhost 0.0.0.0
sys snmp trapdst 172.23.15.250
#### server
sys server enable telnet
sys server enable ftp
sys server enable web
sys server enable icmp
sys server port telnet 23
sys server port ftp 21
sys server port web 80
#### client
sys client set telnet 0.0.0.0
sys client set ftp 0.0.0.0
sys client set web 0.0.0.0
sys client set icmp 0.0.0.0
#### syslog
sys syslog enable
sys syslog server 172.23.15.240
sys syslog facility 1
#### timeserver
sys timeserver set time 172.23.15.240 utc+0800 nosync
#### watchdog
sys wdog set 10000
```

### 32.3.3 Editable Configuration File Upload

You can upload the configuration file by following the steps below.

Use an FTP client to connect to the AAM.

```
C:\> ftp <AAM IP address>
```

Enter the User name (just press [ENTER]).

```
User: [ENTER]
```

Enter the management password (1234 by default).

```
Password: 1234
```

```
230 Logged in
```

```
ftp> put xxx.dat config-0
```

Quit FTP.

```
ftp> quit
```

Wait for the update to finish. The system restarts automatically.

## 32.4 Firmware File Upgrade

Use the following procedure to upload firmware to the AAM.

Use an FTP client to connect to the AAM.

```
C:\> ftp <AAM IP address>
```

Enter the User name (just press [ENTER]).

```
User: [ENTER]
```

Enter the management password (1234 by default).

```
Password: 1234
```

```
230 Logged in
```

Transfer the firmware file to the AAM. The firmware file on your computer (that you want to put onto the AAM) is named firmware.bin. The internal firmware file on the AAM is named ras.

```
ftp> put firmware.bin ras
```

Quit FTP.

```
ftp> quit
```

Wait for the update to finish. The AAM restarts automatically.

# CHAPTER 33

## Troubleshooting

This chapter covers potential problems and possible remedies. After each problem description, some steps are provided to help you to diagnose and solve the problem.

### 33.1 The SYS or PWR LED Does Not Turn On

**Table 68** SYS LED Troubleshooting

STEPS	CORRECTIVE ACTION
1	Make sure the power wires are properly connected to the power supply and the power supply is operating normally. Make sure you are using the correct power source (refer to the appendices).
2	Make sure the power wires are connected properly.
3	The LED itself or the unit may be faulty; contact your vendor.

### 33.2 The ALM LED Is On

The **ALM** (alarm) LED lights when the AAM is overheated or the voltage readings are outside the tolerance levels.

**Table 69** ALM LED Troubleshooting

STEPS	CORRECTIVE ACTION
1	Use the statistics monitor command to verify the cause of the alarm. See step 2 if the unit is overheated, and step 3 if the voltages are out of the allowed ranges.
2	Ensure that the AAM is installed in a well-ventilated area and that normal operation of the fans is not inhibited. Keep the bottom, top and all sides clear of obstructions and away from the exhaust of other equipment.
3	If the voltage levels are outside the allowed range, take a screen shot of the statistics monitor command display and contact your vendor.

## 33.3 DSL Data Transmission

The DSL link is up, but data cannot be transmitted.

**Table 70** DSL Data Transmission Troubleshooting

STEPS	CORRECTIVE ACTION
1	Check the AAM's switch mode and port isolation settings. Check to see that the VPI/VCI and multiplexing mode (LLC/VC) settings in the subscriber's ADSL modem or router match those of the ADSL port. If the subscriber is having problems with a video or other high-bandwidth services, make sure the AAM's ADSL port's data rates are set high enough.
2	Check the VLAN configuration.
3	Ping the AAM from the computer behind the ADSL modem or router.
4	If you cannot ping, connect a DSL modem to an ADSL port (that is known to work). If the ADSL modem or router works with a different ADSL port, there may be a problem with the original port. Contact the distributor.
5	If using a different port does not work, try a different ADSL modem or router with the original port.

## 33.4 There Is No Voice on an ADSL Connection

The AAM has internal POTS (Plain Old Telephone Service) splitters and Telco-50 connector CO pins that allow the telephone wiring used for ADSL connections to also simultaneously carry normal voice conversations.

**Table 71** ADSL Voice Troubleshooting

STEPS	CORRECTIVE ACTION
1	Make sure the subscriber has a POTS splitter properly installed.
2	Check the ADSL line pin assignments shown in the pin assignments appendix.
3	Check the telephone wire connections between the subscriber and the MDF(s).
4	Check the telephone wire and connections between the MDF(s) and the <b>USER</b> lines of the Telco-50 connector.
5	Check the telephone wire and connections between the MDF(s) and the <b>CO</b> lines of the Telco-50 connector. Check the connection from the MDF(s) to the telephone company or the PBX.
6	Check the telephone wire mapping on the MDF(s).
7	Make sure the in-house wiring works and is connected properly.
8	Repeat the steps above using a different ADSL port.

## 33.5 Testing Wiring

Use the following tests if there is no voice.

Systematically test wiring using a functioning telephone to determine if there is a wiring problem. If the connection is good, the telephone will return a dial tone. Letters in the figure shown next indicate the systematic tests to be done. Suppose you're using installation scenario "B" as shown in the chapter on MDF connections. The logic for other scenarios should be similar.

Use steps A-D if there is no voice but you can transmit data. Use all of the steps if there is no voice and you cannot transmit data.

- A. Test A determines if there is a wiring problem between the TELCO (telephone company) and MDF 1.
  - B. Test B determines if there is a wiring problem between MDF 1 and MDF 2.
  - C. Test C determines if there is a wiring problem between MDF 2 and your device.
  - D. Test D determines if there is a problem with your device's internal splitter.
  - E. Test E determines if there is a wiring problem between your device and MDF 3.
  - F. Test F determines if there is a building-wiring problem between the subscriber's wall jack and MDF 3.
- A. Test A determines if there is a wiring problem between the TELCO (telephone company) and MDF 1.

**Figure 169** Testing In-house Wiring

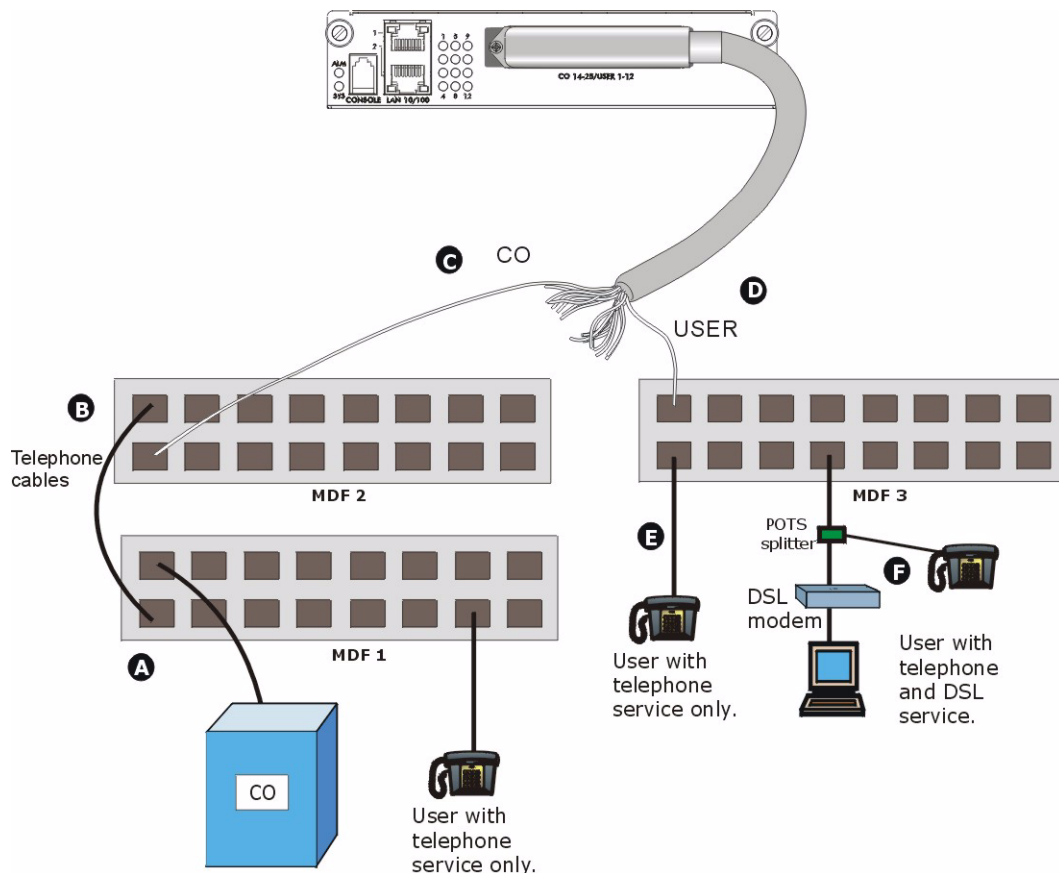

**Table 72** Testing In-house Wiring

STEPS	TEST
A	Connect a standard telephone to MDF 1. If there is no dial tone, then a problem with the wire or wire connections between MDF 1 and the TELCO exists. Contact your telephone company for troubleshooting.
B	Connect a telephone to the upper port of MDF 2. If there is no dial tone, then the problem is between MDF 1 and MDF 2. Check the telephone wire and connections between MDFs 1 and 2.
C	Disconnect the telephone wire from the <b>CO</b> pin. Connect a telephone to the telephone wire. If there is no dial tone, then the problem is between your device and MDF 2. Check the telephone wire's pin assignments (refer to the appendices for the proper pin assignments). Replace the telephone wire if the pin assignments are OK and there is still no dial tone.
D	Reconnect the telephone wire to the <b>CO</b> pin. Disconnect the telephone wire from the <b>USER</b> pin. Connect a telephone to the <b>USER</b> pin (refer to the appendices for the proper pin assignments). If there is no dial tone, your device's internal splitter may be faulty, contact your vendor.
E	Reconnect the telephone wire to the <b>USER</b> pin. Connect a telephone to a lower port of MDF 3. If there is no dial tone, then the problem is between your device and MDF 3. Check the pin assignments of the telephone wire's connector that connects to the <b>USER</b> pin. Replace the telephone wire connecting your device to MDF 3. If there is no dial tone, then MDF 3 may be faulty. Contact the telephone company if that is the case.
F	Disconnect the DSL modem from the wall jack and connect the telephone to the wall jack. If there is no dial tone, then there is a problem with the building wiring between the DSL subscriber's home and the MDF. Contact your telephone company for troubleshooting.

## 33.6 Local Server

The computer behind a DSL modem or router cannot access a local server connected to the AAM.

**Table 73** Local Server Troubleshooting

STEPS	CORRECTIVE ACTION
1	Refer to <a href="#">Section 33.3 on page 270</a> to make sure that the subscriber is able to transmit to the AAM.
2	Make sure the computer behind the DSL device has the correct gateway IP address configured.
3	Check the VLAN configuration (refer to the chapter on VLAN).
4	Check the cable and connections between the AAM and the local server.
5	Try to access another local server. If data can be transmitted to a different local server, the local server that could not be accessed may have a problem.

## 33.7 Data Rate

The SYNC-rate is not the same as the configured rate.

**Table 74** SYNC-rate Troubleshooting

STEPS	CORRECTIVE ACTION
1	Connect the ADSL modem or router directly to the ADSL port using a different telephone wire.
2	If the rates match, the quality of the telephone wiring that connects the subscriber to the ADSL port may be limiting the speed to a certain rate. If they do not match when a good wire is used, contact the distributor.

## 33.8 Configured Settings

The configured settings do not take effect.

**Table 75** Configured Settings Troubleshooting

CORRECTIVE ACTION
Use the <b>Config Save</b> button or command after you finish configuring to save the AAM's settings.

## 33.9 Password

If you forget your password, you will need to use the console port to reload the factory-default configuration file (see [Section 33.13.1 on page 275](#)).

## 33.10 SNMP

The SNMP manager server cannot get information from the AAM.

**Table 76** SNMP Server Troubleshooting

STEPS	CORRECTIVE ACTION
1	Ping the AAM from the SNMP server. If you cannot, check the cable, connections and IP configuration.
2	Check to see that the community (or trusted host) in the AAM matches the SNMP server's community.
3	Make sure that your computer's IP address matches a configured trusted host IP address (if configured).

## 33.11 Telnet

I cannot telnet into the AAM.

**Table 77** Telnet Troubleshooting

STEPS	CORRECTIVE ACTION
1	Make sure that a telnet session is not already operating. The AAM only accepts one telnet session at a time.
2	Make sure that your computer's IP address matches a configured secured client IP address (if configured). The AAM immediately disconnects the telnet session if secured host IP addresses are configured and your computer's IP address does not match one of them.
3	Make sure that you have not disabled the Telnet service or changed the server port number that the AAM uses for Telnet.
4	Ping the AAM from your computer. If you are able to ping the AAM but are still unable to telnet, contact the distributor. If you cannot ping the AAM, check the cable, connections and IP configuration.

## 33.12 Switch Lockout

You could block yourself (and all others) from accessing the switch through the web configurator if you do one of the following:

- 1 Filtering all traffic to the CPU port. The “CPU port” is the management port of the switch.
- 2 Disabling all ports.
- 3 Misconfiguring the text configuration file.
- 4 Forgetting the password and/or IP address.
- 5 Preventing all services from accessing the switch.
- 6 Changing a service port number but forgetting it.

**Note:** Be careful not to lock yourself and others out of the AAM.

## 33.13 Resetting the Defaults

You can upload the factory-default configuration file to reset the AAM to the default settings. This means that you will lose all previous configurations and the speed of the console port will be reset to the default of 9600bps with 8 data bit, no parity, one stop bit and flow control set to none. The password will also be reset to “1234” and the IP address to 192.168.1.1.

### 33.13.1 Resetting the Defaults Via CLI Command

If you know the password, you can reload the factory-default configuration file via Command Line Interface (CLI) command. Use the following procedure.

- 1 Connect to the console port using a computer with terminal emulation software. See the chapter on hardware connections for details.
- 2 Enter your password.
- 3 Type `config restore`.
- 4 Type `y` at the question “Do you want to proceed(y/n)?”
- 5 The AAM restarts.

**Figure 170** Resetting the AAM Via Command

```
ras> config restore

System will reboot automatically after restoring default
configuration.
Do you want to proceed(y/n)? >
restoring configuration...
saving configuration to flash...
```

The AAM is now reinitialized with a default configuration file including the default password of “1234”.

### 33.13.2 Resetting the Defaults Via Boot Commands

If you forget your password or cannot access the AAM, you will need to use this section to reload the factory-default configuration file. Uploading the factory-default configuration file replaces the current configuration file with the factory-default configuration file. This means that you will lose all previous configurations and the speed of the console port will be reset to the default of 9600bps with 8 data bit, no parity, one stop bit and flow control set to none. The password will also be reset to “1234” and the IP address to 192.168.1.1.

**Note:** Uploading the factory default configuration file erases the AAM's entire configuration.

Obtain the default configuration file, unzip it and save it in a folder. Use a console cable to connect a computer with terminal emulation software to the AAM's console port. Turn the IES-1000 off and then on to begin a session. When you turn on the IES-1000 again you will see the initial screen. When you see the message `Press any key to enter Debug Mode within 3 seconds press any key to enter debug mode.`

To upload the configuration file, do the following:

- 1 Type `atlc` after the `Enter Debug Mode message.`

- 2 Wait for the `Starting XMODEM` upload message before activating XMODEM upload on your terminal.
- 3 This is an example Xmodem configuration upload using HyperTerminal. Click **Transfer**, then **Send File** to display the following screen.

**Figure 171** Example Xmodem Upload

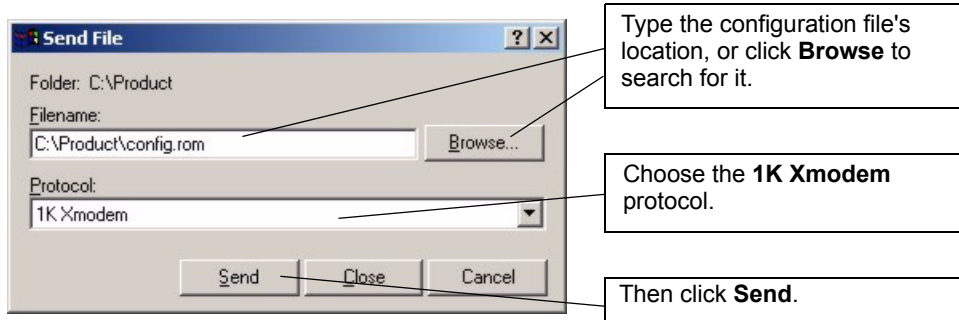

- 4 After a successful configuration file upload, type `atgo` to restart the AAM.

The AAM is now reinitialized with a default configuration file including the default password of "1234".

## 33.14 Recovering the Firmware

Usually you should use the web configurator, FTP or console port to upload the AAM's firmware. If the AAM will not start up, the firmware may be lost or corrupted. Use the following procedure to upload firmware to the AAM only when you are unable to use another method to upload firmware.

**Note:** This procedure is for emergency situations only.

- 1 Obtain the firmware file, unzip it and save it in a folder on your computer.
- 2 Connect your computer to the console port and use terminal emulation software configured to the following parameters:
  - VT100 terminal emulation
  - 9600 bps
  - No parity, 8 data bits, 1 stop bit
  - No flow control
- 3 Turn off the IES-1000 and turn it back on to restart it and begin a session.
- 4 When you see the `Press any key to enter Debug Mode within 3 seconds` message, press a key to enter debug mode.
- 5 Type `atba5` after the `Enter Debug Mode` message (this changes the console port speed to 115200 bps).
- 6 Change the configuration of your terminal emulation software to use 115200 bps and reconnect to the AAM.

- 7 Type `atur` after the `Enter Debug Mode` message.
- 8 Wait for the `Starting XMODEM upload` message before activating XMODEM upload on your terminal.
- 9 This is an example Xmodem configuration upload using HyperTerminal. Click **Transfer**, then **Send File** to display the following screen.

**Figure 172** Example Xmodem Upload

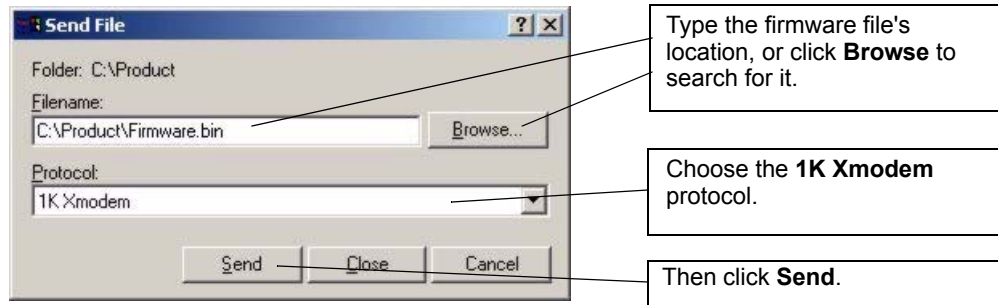

- 10 After a successful firmware upload, type `atgo` to restart the AAM. The console port speed automatically changes back to 9600 bps when the AAM restarts.



# APPENDIX A

## Product Specifications

This appendix gives details about the AAM hardware and features.

### Specification Tables

**Table 78** Device Specifications

Default IP Address	192.168.1.1
Default Subnet Mask	255.255.255.0 (24 bits)
User Name	admin
Default Password	1234
Dimensions	166.8 mm (W) x 296 mm (D) x 44.45 mm (H)
Weight	1.234 kg
Power Specification	15V DC 25Watts
Interface	<ul style="list-style-type: none"> <li>• One Telco-50 connector: 12 ADSL Ports (Pin 1~12 and 26~37 for USER, Pin 14~25 and 39~50 for CO)</li> <li>• One mini RJ11 console port for local management</li> <li>• Two 10/100BASE-T Ethernet ports for uplink</li> </ul>
MAC Address Table	Up to 16K entries
ARP Table	Up to 500 entries
Operation Temperature	0° C ~ 50° C
Storage Temperature	-40° C ~ 85° C
Operation Humidity	10% ~ 95% RH (non-condensing)
Storage Humidity	5% ~ 95% RH (non-condensing)
Certifications	Safety UL1950 CSA C22.2 No. 950 EN60950-1, EN41003 EMC FCC Part 15 Class A EN55022 Class A
System Management	<ul style="list-style-type: none"> <li>• Embedded Web Configurator (HTTP)</li> <li>• CLI (Command Line Interpreter)</li> <li>• Remote Management via Telnet or Web</li> <li>• SNMP manageable</li> <li>• Firmware Upgrade (web configurator, FTP)</li> </ul>

**Table 78** Device Specifications

Other Features	<ul style="list-style-type: none"><li>• MAC filtering</li><li>• MAC count limiting</li><li>• Access Control List</li><li>• Hardware-based multicasting</li><li>• IEEE 802.1Q VLAN Tagging</li><li>• GVRP</li><li>• IEEE 802.1p CoS with priority queuing</li><li>• IEEE 802.1w RSTP</li><li>• IGMP v1 &amp; v 2 snooping</li><li>• DHCP relay option82</li><li>• IEEE 802.1x Port-based Authentication</li><li>• SNMP v1 &amp; v2c</li></ul>
MIBs	<ul style="list-style-type: none"><li>• MIB-II, IF-MIB, Q-MIB, P-MIB</li><li>• ADSL line MIB</li><li>• ZyXEL proprietary MIBs</li></ul>

## Wire Gauge Specifications

**Table 79** Wire Gauge Specifications

WIRE TYPE	REQUIRED AWG NO. (DIAMETER)
Ground Wire	18 or larger
Telephone Wire	26 or larger
Power Wire	16 to 18

AWG (American Wire Gauge) is a measurement system for wire that specifies its thickness. As the thickness of the wire increases, the AWG number decreases.

## Telco-50 Connector Pin Assignments

The following diagram shows the pin assignments of the Telco-50 connector.

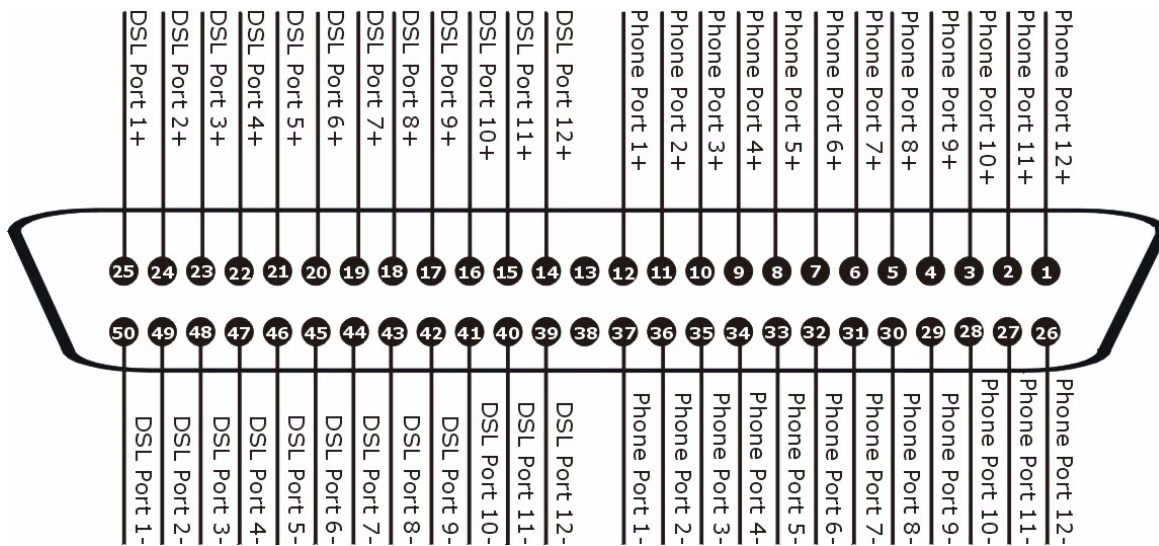
**Figure 173** Telco-50 Pin Assignments

This table lists the ports and matching pin numbers for the hardware Telco-50 connector.

**Table 80** Hardware Telco-50 Connector Port and Pin Numbers

PORT NUMBER	PIN NUMBER
1	USER (25, 50), CO (12, 37)
2	USER (24, 49), CO (11, 36)
3	USER (23, 48), CO (10, 35)
4	USER (22, 47), CO (9, 34)
5	USER (21, 46), CO (8, 33)
6	USER (20, 45), CO (7, 32)
7	USER (19, 44), CO (6, 31)
8	USER (18, 43), CO (5, 30)
9	USER (17, 42), CO (4, 29)
10	USER (16, 41), CO (3, 28)
11	USER (15, 40), CO (2, 27)
12	USER (14, 39), CO (1, 26)

## Console Cable Pin Assignments

The following diagrams and chart show the pin assignments of the console cable.

**Figure 174** Console Cable RJ-11 Male Connector

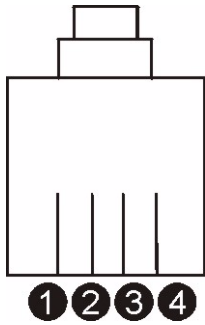

**Figure 175** Console Cable DB-9 Female Connector

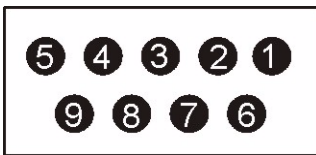

**Table 81** Console Cable Connector Pin Assignments

RJ-11 MALE	DB-9 FEMALE
Pin 2: TXD	Pin 2
Pin 3: RXD	Pin 3
Pin 4: GND	Pin 5

# APPENDIX B

## Virtual Circuit Topology

ATM is a connection-oriented technology, meaning that it sets up virtual circuits over which end systems communicate. The terminology for virtual circuits is as follows:

- Virtual Channel      Logical connections between ATM switches
- Virtual Path        A bundle of virtual channels
- Virtual Circuits     A series of virtual paths between circuit end point

**Figure 176** Virtual Circuit Topology

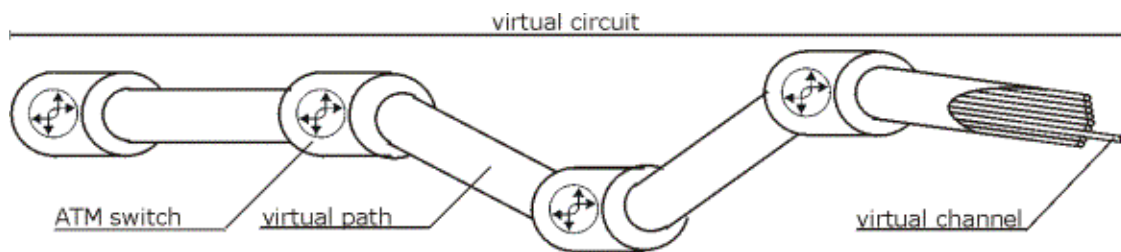

Think of a virtual path as a cable that contains a bundle of wires. The cable connects two points and wires within the cable provide individual circuits between the two points. In an ATM cell header, a VPI (Virtual Path Identifier) identifies a link formed by a virtual path; a VCI (Virtual Channel Identifier) identifies a channel within a virtual path.

The VPI and VCI identify a virtual path, that is, termination points between ATM switches. A series of virtual paths make up a virtual circuit.



# Index

## Numerics

1 Day Performance Command [260](#)  
 110V AC [3](#)  
 15 Minute Performance Command [258](#)  
 230V AC [3](#)

## A

AC [3](#)  
 Access control [157](#)  
 Accessories [3](#)  
 Address Resolution Protocol [243](#)  
 Address Resolution Protocol (ARP) [165](#)  
 ADSL Disable Command [201](#)  
 ADSL Enable Command [201](#)  
 ADSL Loopback Command [206](#)  
 ADSL Name Command [205](#)  
 ADSL Profile Delete Command [204](#)  
 ADSL Profile Map Command [204](#)  
 ADSL Profile Set Command [202](#)  
 ADSL Profile Show Command [202](#)  
 ADSL Show Command [200](#), [254](#)  
 ADSL Standards [195](#)  
 ADSL Tel Command [205](#)  
 Agent Information [226](#)  
 Airflow [3](#)  
 ALM LED [269](#)  
 American Wire Gauge [3](#), [280](#)  
 Annex A [256](#)  
 ARP [243](#)  
   How it works [165](#)  
   View [165](#)  
 ARP Flush Command [249](#)  
 ARP Show Command [247](#), [248](#), [249](#)  
 Automatic VLAN registration [112](#)  
 AWG [3](#), [280](#)

## B

Basement [3](#)

## C

Cables, Connecting [3](#)  
 CFI (Canonical Format Indicator) [111](#)  
 CI Commands [167](#)  
 CLI Command [275](#)  
   Configure tagged VLAN example [234](#)  
   Static VLAN Table example [232](#)  
 Command  
   Forwarding Process Example [232](#)  
 Command Line Interface [167](#), [275](#)  
 Commands  
   Abbreviations [167](#)  
   Config Save Command [167](#)  
   Configuration File [266](#)  
     Edit [267](#)  
   Configuration file  
     Backup [154](#)  
     Restore [154](#)  
   Configuration File Backup [266](#)  
 Connecting Cables [3](#)  
 Console Port [276](#)  
 Console port [30](#)  
   Settings [38](#)  
 Copyright [1](#)  
 Corrosive Liquids [3](#)  
 Covers [3](#)  
 Customer Support [5](#)

## D

Damage [3](#), [265](#)  
 Dampness [3](#)  
 Danger [3](#)  
 Default In-band IP Address [246](#)  
 Delete Virtual Channel Profile Command [214](#)  
 Denmark, Contact Information [5](#)  
 DHCP [225](#), [243](#)  
 DHCP Relay  
   Disable Command [226](#)  
   Enable Command [226](#)  
   Server Set Command [225](#)  
   Show Command [226](#)  
 Diagnostic [157](#)

Ethernet port test [158](#)  
Ping [158](#)  
System log [158](#)  
Discrete Multi-Tone [255](#)  
Downstream (ds) [257](#)  
Dust [3](#)  
DVLAN Table [227](#)  
Dynamic Host Configuration Protocol [225](#), [243](#)

## E

EAPoL [244](#)  
Electric Shock [3](#)  
Electrical Pipes [3](#)  
Electrocution [3](#)  
Ethernet port test [158](#)  
Ethernet ports  
  Default settings [38](#)  
Europe [3](#)  
Exposure [3](#)  
Extensible Authentication Protocol, [244](#)

## F

File Upload [267](#)  
Filename Conventions [265](#)  
Filtering Databases [227](#)  
Finland, Contact Information [5](#)  
Firmware  
  Upgrade [153](#)  
Firmware File Upgrade [268](#)  
Forwarding Process Example [232](#)  
France, Contact Information [5](#)  
Front panel [37](#)  
FTP [156](#)

## G

G.lite [205](#)  
G.SHDSL modem [270](#)  
GARP [112](#), [228](#)  
GARP (Generic Attribute Registration Protocol) [112](#)  
GARP terminology [113](#)  
GARP timer [113](#)  
Gas Pipes [3](#)

General IP Commands [247](#)  
Germany, Contact Information [5](#)  
Get Community Command [185](#)  
Ground Wire [280](#)  
GVRP [113](#), [117](#), [228](#)  
GVRP (GARP VLAN Registration Protocol) [113](#)

## H

Hardware installation [35](#)  
Hardware overview [37](#)  
High Voltage Points [3](#)

## I

IEEE 802.1Q Tagged VLAN [227](#)  
IGMP [244](#)  
IGMP Filter Profile Delete Command [224](#)  
IGMP Filter Profile Set Command [223](#)  
IGMP Filter Profile Show Command [224](#)  
IGMP Filter Set Command [222](#)  
IGMP Filter Show Command [222](#)  
In-band IP Settings [245](#)  
Info Show Command [183](#)  
Interleave Delay [256](#)  
Internet Group Multicast Protocol [244](#)  
Internet Protocol [243](#)  
Introduction [29](#)  
IP [243](#)  
ITU-T G.992.1 [255](#)

## L

LAN CPU Set Command [234](#)  
Lightning [3](#)  
line bit allocation [254](#)  
Line Diagnostics Get Command [207](#)  
Line Diagnostics Set Command [207](#)  
Line Operating Values [256](#)  
line performance counters [257](#)  
Linedata Command [254](#)  
Lineinfo Command [255](#)  
Lineperf Command [257](#)  
Liquids, Corrosive [3](#)

Lockout [274](#)  
Log [158](#)  
Log Clear Command [192](#), [193](#)  
Log Show Command [191](#), [192](#)

## M

MAC Count [240](#)  
MAC Count Disable Command [241](#)  
MAC Count Enable Command [240](#)  
MAC Count Set Command [241](#)  
MAC Count Show Command [240](#)  
MAC Filter  
    Filter [237](#)  
MAC Filter Delete Command [239](#)  
MAC Filter Disable Command [238](#)  
MAC Filter Enable Command [238](#)  
MAC Filter Set Command [239](#)  
MAC Filter Show Command [237](#)  
MAC table  
    How it works [163](#)  
    View [164](#)  
Maintenance [153](#)  
Modify a Static VLAN Table Example [232](#)

## N

NetBIOS [243](#)  
Network Basic Input/Output System [243](#)  
North America [3](#)  
North America Contact Information [5](#)  
Norway, Contact Information [5](#)

## O

OAMF5 Loopback [206](#)  
Opening [3](#)  
Operational Mode [204](#), [207](#)  
Operational, Administration and Maintenance Function 5  
    Test [206](#)  
Option 82 [226](#)  
    Disable Command [227](#)  
    Enable Command [226](#)  
    Set Command [227](#)

## P

Packet Filter Set Command [243](#)  
Packet Filter Show Command [242](#)  
Ping [158](#)  
Ping Command [247](#)  
Pipes [3](#)  
Point-to-Point Protocol over Ethernet) [243](#)  
Pool [3](#)  
Port authentication [137](#)  
Port Set Command [204](#)  
Port Statistics [252](#)  
Power Adaptor [3](#)  
Power Cord [3](#)  
Power Outlet [3](#)  
Power Supply [3](#)  
Power Supply, repair [3](#)  
Power Wire [280](#)  
PPPoE [243](#)  
PU VLAN [235](#)  
PVC Channels [214](#)  
PVC Delete Command [216](#)  
PVC Set Command [215](#)  
PVC Show Command [214](#)  
PVID [117](#)  
PWR LED [269](#)  
PWR LED Does Not Turn On [269](#)

## Q

Qualified Service Personnel [3](#)

## R

Recovering the Firmware [276](#)  
Regular Mail [5](#)  
Related Documentation [27](#)  
Removing [3](#)  
Repair [3](#)  
Reset to factory default settings [155](#)  
Resetting the Defaults [275](#)  
RFC 2131 [225](#)  
RFC 2132 [225](#)  
RFC 2486 [244](#)  
Risk [3](#)  
Risks [3](#)

Route Delete Command [248](#)

Route Set Command [247](#)

## S

Safety Warnings [3](#)

Saving Configuration [167](#)

Service [3, 4](#)

Service Personnel [3](#)

Set Community Command [185](#)

Set Virtual Channel Profile Command [212](#)

SHDSL Port [270](#)

Shock, Electric [3](#)

Show Command [247](#)

Show SNMP Settings Command [186](#)

Show Virtual Channel Profile Command [212](#)

SNMP [184](#)

    Configuring [185](#)

Spain, Contact Information [5](#)

Statistics ADSL Commands [254](#)

Statistics IP Command [261, 263](#)

Statistics Monitor [252](#)

Statistics Port [252](#)

Status

    STP [129](#)

STP

    Bridge priority [131](#)

    Configuration [131](#)

    Forwarding Delay [132](#)

    Hello Time [131](#)

    Max Age [132](#)

    Path cost [132](#)

    Port priority [132](#)

    Status [129](#)

Supply Voltage [3](#)

Support E-mail [5](#)

SVLAN Table [227](#)

Sweden, Contact Information [5](#)

Swimming Pool [3](#)

Switch Lockout [274](#)

Syntax Conventions [27](#)

SYS LED [269](#)

SYS LED Does Not Turn On [269](#)

SYS LED Troubleshooting [269](#)

System log [158](#)

System reboot [155](#)

## T

Tagged Frames [232](#)

Tagged VLAN [111](#)

Telco-50 Connector Pin Assignments [280, 281](#)

Telecommunication Line Cord. [3](#)

Telephone [5](#)

Telephone Number [206](#)

Telephone Wire [280](#)

Terminal Emulation [276](#)

Terminal emulation [276](#)

Testing Wiring [270](#)

Thunderstorm [3](#)

Tone [255](#)

Trap Community Command [186](#)

Trap Destination Set Command [186](#)

Troubleshooting [269](#)

Trusted Host Set Command [185](#)

## U

Untagged Frames [233](#)

Upstream (us) [257](#)

USER Telco-50 Connectors [280, 281](#)

## V

Vendor [3](#)

Ventilation Slots [3](#)

VID [111](#)

    Number of possible VIDs [112](#)

    Priority frame [112](#)

VID (VLAN Identifier) [111](#)

Virtual Channel Profile Commands [212](#)

VLAN [111, 270](#)

    Acceptable frame type [117](#)

    Automatic registration [112](#)

    Explicit Tagging [227](#)

    ID [111](#)

    ID (VID) [228](#)

    Implicit Tagging [227](#)

    Port settings [116](#)

    Registration Information [227](#)

    Status [114](#)

    Tagged [111](#)

VLAN CPU Show Command [234](#)

VLAN Delete Command [235](#)

VLAN Disable [236](#)  
VLAN Enable [236](#)  
VLAN Port Show Command [230](#)  
VLAN Priority Command [235](#)  
VLAN PVID Command [231](#)  
VLAN Set Command [231](#)  
VLAN Show Command [236](#)  
Voltage Supply [3](#)  
Voltage, High [3](#)  
VPI [206](#)  
VT100 [276](#)

## W

Wall Mount [3](#)  
Warnings [3](#)  
Water [3](#)  
Water Pipes [3](#)  
Web configurator  
  Logout [53](#)  
Web Site [5](#)  
Wet Basement [3](#)  
Wire Gauge [280](#)  
Worldwide Contact Information [5](#)

## X

XMODEM Upload [277](#)  
XMODEM upload [276](#)

## Z

ZyNOS [265](#)  
ZyXEL Limited Warranty  
  Note [4](#)  
ZyXEL Network Operating System [265](#)