

D-Link[®]

DFE-2600 Series Ethernet/Fast Ethernet Dual-Speed Managed/Unmanaged Stackable Hubs User's Guide

Rev. 01 (March, 1998)

6DFE2600M.01
Printed In Taiwan



RECYCLABLE

Wichtige Sicherheitshinweise

1. Bitte lesen Sie sich diese Hinweise sorgfältig durch.
2. Heben Sie diese Anleitung für den spätern Gebrauch auf.
3. Vor jedem Reinigen ist das Gerät vom Stromnetz zu trennen. Verwenden Sie keine Flüssig- oder Aerosolreiniger. Am besten dient ein angefeuchtetes Tuch zur Reinigung.
4. Um eine Beschädigung des Gerätes zu vermeiden sollten Sie nur Zubehörteile verwenden, die vom Hersteller zugelassen sind.
5. Das Gerät is vor Feuchtigkeit zu schützen.
6. Bei der Aufstellung des Gerätes ist auf sichern Stand zu achten. Ein Kippen oder Fallen könnte Verletzungen hervorrufen. Verwenden Sie nur sichere Standorte und beachten Sie die Aufstellhinweise des Herstellers.
7. Die Belüftungsöffnungen dienen zur Luftzirkulation die das Gerät vor Überhitzung schützt. Sorgen Sie dafür, daß diese Öffnungen nicht abgedeckt werden.
8. Beachten Sie beim Anschluß an das Stromnetz die Anschlußwerte.
9. Die Netzanschlußsteckdose muß aus Gründen der elektrischen Sicherheit einen Schutzleiterkontakt haben.
10. Verlegen Sie die Netzanschlußleitung so, daß niemand darüber fallen kann. Es sollete auch nichts auf der Leitung abgestellt werden.
11. Alle Hinweise und Warnungen die sich am Geräten befinden sind zu beachten.
12. Wird das Gerät über einen längeren Zeitraum nicht benutzt, sollten Sie es vom Stromnetz trennen. Somit wird im Falle einer Überspannung eine Beschädigung vermieden.
13. Durch die Lüftungsöffnungen dürfen niemals Gegenstände oder Flüssigkeiten in das Gerät gelangen. Dies könnte einen Brand bzw. Elektrischen Schlag auslösen.
14. Öffnen Sie niemals das Gerät. Das Gerät darf aus Gründen der elektrischen Sicherheit nur von autorisiertem Servicepersonal geöffnet werden.
15. Wenn folgende Situationen auftreten ist das Gerät vom Stromnetz zu trennen und von einer qualifizierten Servicestelle zu überprüfen:
 - a– Netzkabel oder Netzstecker sint beschädigt.
 - b– Flüssigkeit ist in das Gerät eingedrungen.
 - c– Das Gerät war Feuchtigkeit ausgesetzt.
 - d– Wenn das Gerät nicht der Bedienungsanleitung entsprechend funktioniert oder Sie mit Hilfe dieser Anleitung keine Verbesserung erzielen.
 - e– Das Gerät ist gefallen und/oder das Gehäuse ist beschädigt.
 - f– Wenn das Gerät deutliche Anzeichen eines Defektes aufweist.
16. Bei Reparaturen dürfen nur Originalersatzteile bzw. den Orginalteilen entsprechende Teile verwendet werden. Der Einsatz von ungeeigneten Ersatzteilen kann eine weitere Beschädigung hervorrufen.
17. Wenden Sie sich mit allen Fragen die Service und Repartur betreffen an Ihren Servicepartner. Somit stellen Sie die Betriebssicherheit des Gerätes sicher.

Limited Warranty

Hardware:

D-Link warrants its hardware products to be free from defects in workmanship and materials, under normal use and service, for the following periods measured from date of purchase from D-Link or its Authorized Reseller:

<u>Product Type</u>	<u>Warranty Period</u>
Complete products	One year
Spare parts and spare kits	90 days

The one-year period of warranty on complete products applies on condition that the product's Registration Card is filled out and returned to a D-Link office within ninety (90) days of purchase. A list of D-Link offices is provided at the back of this manual, together with a copy of the Registration Card. Failing such timely registration of purchase, the warranty period shall be limited to 90 days.

If the product proves defective within the applicable warranty period, D-Link will provide repair or replacement of the product. D-Link shall have the sole discretion whether to repair or replace, and replacement product may be new or reconditioned. Replacement product shall be of equivalent or better specifications, relative to the defective product, but need not be identical. Any product or part repaired by D-Link pursuant to this warranty shall have a warranty period of not less than 90 days, from date of such repair, irrespective of any earlier expiration of original warranty period. When D-Link provides replacement, then the defective product becomes the property of D-Link.

Warranty service may be obtained by contacting a D-Link office within the applicable warranty period, and requesting a Return Material Authorization (RMA) number. If a Registration Card for the product in question has not been returned to D-Link, then a proof of purchase (such as a copy of the dated purchase invoice) must be provided. If Purchaser's circumstances require special handling of warranty correction, then at the time of requesting RMA number, Purchaser may also propose special procedure as may be suitable to the case.

After an RMA number is issued, the defective product must be packaged securely in the original or other suitable shipping package to ensure that it will not be damaged in transit, and the RMA number must be prominently marked on the outside of the package. The package must be mailed or otherwise shipped to D-Link with all costs of mailing/shipping/insurance prepaid; D-Link will ordinarily reimburse Purchaser for mailing/shipping/insurance expenses incurred for return of defective product in accordance with this warranty. D-Link shall never be responsible for any software, firmware, information, or memory data of Purchaser contained in, stored on, or integrated with any product returned to D-Link pursuant to this warranty.

Any package returned to D-Link without an RMA number will be rejected and shipped back to Purchaser at Purchaser's expense, and D-Link reserves the right in such a case to levy a reasonable handling charge in addition mailing or shipping costs.

Software:

Warranty service for software products may be obtained by contacting a D-Link office within the applicable warranty period. A list of D-Link offices is provided at the back of this manual, together with a copy of the Registration Card. If a Registration Card for the product in question has not been returned to a D-Link office, then a proof of purchase (such as a copy of the dated purchase invoice) must be provided when requesting warranty service. The term "purchase" in this software warranty refers to the purchase transaction and resulting license to use such software.

D-Link warrants that its software products will perform in substantial conformance with the applicable product documentation provided by D-Link with such software product, for a period of ninety (90) days from the date of purchase from D-Link or its Authorized Reseller. D-Link warrants the magnetic media, on which D-Link provides its software product, against failure during the same warranty period. This warranty applies to purchased software, and to replacement software provided by D-Link pursuant to this warranty, but shall not apply to any update or replacement which may be provided for download via the Internet, or to any update which may otherwise be provided free of charge.

D-Link's sole obligation under this software warranty shall be to replace any defective software product with product which substantially conforms to D-Link's applicable product documentation. Purchaser assumes responsibility for the selection of appropriate application and system/platform software and associated reference materials. D-Link makes no warranty that its software products will work in combination with any hardware, or any application or system/platform software product provided by any third party, excepting only such products as are expressly represented, in D-Link's applicable product documentation as being compatible. D-Link's obligation under this warranty shall be a reasonable effort to provide compatibility, but D-Link shall have no obligation to provide compatibility when there is fault in the third-party hardware or software. D-Link makes no warranty that operation of its software products will be uninterrupted or absolutely error-free, and no warranty that all defects in the software product, within or without the scope of D-Link's applicable product documentation, will be corrected.

D-Link Offices for Registration and Warranty Service

The product's Registration Card, included at the back of this manual, must be completed and sent to a D-Link office. To obtain an RMA number for warranty service on a hardware product, or software product, contact the D-Link office nearest you. An address / telephone / fax contact list of international D-Link offices is provided at the back of this manual.

LIMITATION OF WARRANTIES

IF THE D-LINK PRODUCT DOES NOT OPERATE AS WARRANTED ABOVE, THE CUSTOMER'S SOLE REMEDY SHALL BE, AT D-LINK'S OPTION, REPAIR OR REPLACEMENT. THE FOREGOING WARRANTIES AND REMEDIES ARE EXCLUSIVE AND ARE IN LIEU OF ALL OTHER WARRANTIES, EXPRESSED OR IMPLIED, EITHER IN FACT OR BY OPERATION OF LAW, STATUTORY OR OTHERWISE, INCLUDING WARRANTIES OF MERCHANTABILITY AND FITNESS FOR A PARTICULAR PURPOSE. D-LINK NEITHER ASSUMES NOR AUTHORIZES ANY OTHER PERSON TO ASSUME FOR IT ANY OTHER LIABILITY IN CONNECTION WITH THE SALE, INSTALLATION MAINTENANCE OR USE OF D-LINK'S PRODUCTS

D-LINK SHALL NOT BE LIABLE UNDER THIS WARRANTY IF ITS TESTING AND EXAMINATION DISCLOSE THAT THE ALLEGED DEFECT IN THE PRODUCT DOES NOT EXIST OR WAS CAUSED BY THE CUSTOMER'S OR ANY THIRD PERSON'S MISUSE, NEGLIGENCE, IMPROPER INSTALLATION OR TESTING, UNAUTHORIZED ATTEMPTS TO REPAIR, OR ANY OTHER CAUSE BEYOND THE RANGE OF THE INTENDED USE, OR BY ACCIDENT, FIRE, LIGHTNING OR OTHER HAZARD.

LIMITATION OF LIABILITY

IN NO EVENT WILL D-LINK BE LIABLE FOR ANY DAMAGES, INCLUDING LOSS OF DATA, LOSS OF PROFITS, COST OF COVER OR OTHER INCIDENTAL, CONSEQUENTIAL OR INDIRECT DAMAGES ARISING OUT THE INSTALLATION, MAINTENANCE, USE, PERFORMANCE, FAILURE OR INTERRUPTION OF A D- LINK PRODUCT, HOWEVER CAUSED AND ON ANY THEORY OF LIABILITY. THIS LIMITATION WILL APPLY EVEN IF D-LINK HAS BEEN ADVISED OF THE POSSIBILITY OF SUCH DAMAGE.

IF YOU PURCHASED A D-LINK PRODUCT IN THE UNITED STATES, SOME STATES DO NOT ALLOW THE LIMITATION OR EXCLUSION OF LIABILITY FOR INCIDENTAL OR CONSEQUENTIAL DAMAGES, SO THE ABOVE LIMITATION MAY NOT APPLY TO YOU.

Trademarks

Copyright ©1998 D-Link Corporation.

Contents subject to change without prior notice.

D-Link is a registered trademark of D-Link Corporation/D-Link Systems, Inc.

All other trademarks belong to their respective proprietors.

Copyright Statement

No part of this publication may be reproduced in any form or by any means or used to make any derivative such as translation, transformation, or adaptation without permission from D-Link Corporation/D-Link Systems Inc., as stipulated by the United States Copyright Act of 1976.

FCC Warning

This equipment has been tested and found to comply with the limits for a Class A digital device, pursuant to Part 15 of the FCC Rules. These limits are designed to provide reasonable protection against harmful interference when the equipment is operated in a commercial environment. This equipment generates, uses, and can radiate radio frequency energy and, if not installed and used in accordance with this user's guide, may cause harmful interference to radio communications. Operation of this equipment in a residential area is likely to cause harmful interference in which case the user will be required to correct the interference at his own expense.

CE Mark Warning

This is a Class A product. In a domestic environment, this product may cause radio interference in which case the user may be required to take adequate measures.

VCCI A Warning

この装置は、情報処理装置等電波障害自主規制協議会（VCCI）の基準に基づくクラス A 情報技術装置です。この装置を家庭環境で使用すると電波妨害を引き起こすことがあります。この場合には使用者が適切な対策を講ずるよう要求されることがあります。

TABLE OF CONTENTS

ABOUT THIS GUIDE	xi
<i>Models Covered.....</i>	<i>xi</i>
<i>Conventions.....</i>	<i>xi</i>
<i>Overview of the User's Guide.....</i>	<i>xii</i>
CHAPTER 1 : INTRODUCTION.....	1
<i>Product Description</i>	<i>1</i>
<i>Product Features.....</i>	<i>2</i>
<i>Dual-Speed Ethernet Hub.....</i>	<i>4</i>
<i>Technology Overview</i>	<i>4</i>
<i>100BASE-TX Technology Overview.....</i>	<i>5</i>
100Mbps Fast Ethernet Introduction.....	5
Cables and Connectors	6
Topology.....	6
Network Diameter	7
Hub Types.....	7
CHAPTER 2 : UNPACKING AND SETUP	9
<i>Unpacking.....</i>	<i>9</i>
<i>Identifying External Components.....</i>	<i>10</i>
Front Panel.....	10
Rear Panel.....	11
<i>Installing the Hub.....</i>	<i>13</i>

Installation	13
Rack Mounting.....	13
<i>Replacing the Power Supply</i>	15
CHAPTER 3 : UNDERSTANDING INDICATORS.....	17
<i>Hub State Indicators</i>	18
<i>Module Indicators (SLOT1 & 2)</i>	19
<i>Port State Indicators</i>	20
<i>SNMP Indicator</i>	21
<i>Port Speed Indicators</i>	21
<i>Console Port Indicator (CON)</i>	21
CHAPTER 4 : MAKING CONNECTIONS	23
<i>Hub Cascading/Building a Stack</i>	23
<i>Connectivity Rules</i>	25
<i>The Diagnostic Port</i>	26
Diagnostic Port Connection.....	26
<i>Hub to End-Station Connection</i>	27
<i>Hub-to-Hub Uplink</i>	29
<i>Optional Module Connections</i>	31
Module Installation.....	31
Switch Module (DFE-260S).....	32
Fiber Optic Module (DFE-260FX).....	33
Fast Ethernet Module (DFE-260TX).....	34
CHAPTER 5 : MASTER HUB SETUP AND MANAGEMENT	37
<i>Navigation and Conventions</i>	38
<i>In-Band Setup Instructions</i>	39

<i>Backup Master Function</i>	40
<i>Segmenting Hubs</i>	41
<i>Logging in to the Hub Console</i>	43
Logging In.....	43
Changing Your Password	44
<i>Setting Up the Master Hub</i>	46
TCP/IP Settings.....	46
Out-of-Band Management and Console Settings.....	48
Software Update on Boot.....	49
SNMP Information.....	50
SNMP Traps.....	52
SNMP Security (Community Names).....	53
Adding and Deleting Users.....	54
Primary/Backup Master.....	56
<i>Hub Stack Management</i>	57
Controlling Hubs in the Hub Stack	57
Controlling Individual Ports	60
<i>Monitoring the Hub Stack</i>	61
Displaying Port and Group Statistics	62
Displaying Segment Statistics	65
Node Tracking.....	67
Per-Port Intrusion Security	68
Bridge Information.....	68
<i>Resetting the Hub</i>	69
System Reset.....	70
Factory Reset	70

APPENDIX A : CABLES AND CONNECTORS 73

<i>100BASE-TX Ethernet Cable and Connectors</i>	73
<i>Crossover Cables</i>	74
<i>Diagnostic Port Specifications</i>	75
RS-232 (DB9) Pin Specification.....	75

APPENDIX B : BOOT CONFIGURATION FILE..... 77

APPENDIX C : SPECIFICATIONS 81

General 81

Hub-to-Hub Cascading..... 82

LED Indicators..... 82

Environmental and Physical..... 82

APPENDIX D : GLOSSARY..... 85

INDEX..... 93

D-LINK INTERNATIONAL OFFICE CONTACTS 97

WARRANTY REGISTRATION CARD..... 99

ABOUT THIS GUIDE

This guide discusses how to install and use the DFE-2600 series dual-speed, managed/unmanaged, stackable Ethernet/Fast Ethernet Hubs.

Models Covered

Unmanaged Models: DFE-2616, DFE-2616x, DFE-2624, DFE-2624x.

Managed Models: DFE-2616i, DFE-2616ix, DFE-2624i, DFE-2624ix.

All “x” models include a switch module in Slot 1 of the rear panel. All “i” models are intelligent (that is, “managed”) hubs capable of managing an entire hub stack. All “ix” models have both features.

The model numbers also indicate how many ports a particular hub has, thus: 2616 hubs have 16 ports and 2624 hubs have 24 ports.

Conventions

References in this manual to the DFE-2616, DFE-2616x, DFE-2624, DFE-2624x; DFE-2616i, DFE-2616ix, DFE-2624i, and DFE-2624ix hubs are frequently written simply as “hub” or “hubs” where the text applies to all models. Model numbers are normally used only to differentiate between them where necessary.

At points in this document, master models are differentiated by referring to, “DFE-2600 series master hubs.”

Unless differentiated by model number or other specific reference, all information applies to all models.

Overview of the User's Guide

- ◆ Chapter 1, *Introduction*. Provides information on Fast Ethernet networks, and introduces the features of the DFE-2600 series hubs.
- ◆ Chapter 2, *Unpacking and Setup*. Helps you get started in setting up the hub.
- ◆ Chapter 3, *Understanding Indicators*. Describes all LED indicators on the hub's front panel. Understanding these indicators is essential to effectively using the hub.
- ◆ Chapter 4, *Making Connections*. Provides information on connecting to the hub's twisted-pair and console ports, stacking hubs, and linking with other 100BASE-TX hubs.
- ◆ Chapter 5, *Master Hub Setup and Management*. Provides information on using the management agent built into master models in the 2600 series.
- ◆ Appendix A, *Cables and Connectors*. Provides specifications on the cables and connectors used with the hubs.
- ◆ Appendix B, *Boot Configuration File*. Describes the DFE-2600 series master hub boot configuration file.
- ◆ Appendix C, *Specifications*. Lists the hubs' specifications.
- ◆ Appendix D, *Glossary*. Provides the meaning for some networking terms used in this manual.

INTRODUCTION

This chapter introduces the DFE-2600 series dual-speed stackable hubs, as well as giving some background information about the technology the hubs use.

Product Description

The D-Link DFE-2600 series dual-speed stackable Ethernet/Fast Ethernet hubs are designed to allow easy migration and integration between 10Mbps Ethernet and 100Mbps Fast Ethernet, while providing manageability and flexibility in cable connections.

The DFE-2600 hubs can operate with either IEEE 802.3 10BASE-T connections (twisted-pair Ethernet operating at 10 megabits per second), or IEEE 802.3u 100BASE-TX connections (twisted-pair Fast Ethernet operating at 100 megabits per second). All of the twisted-pair ports support NWay auto-negotiation, allowing the hub to automatically detect the speed of a network connection. This means you can connect all of your Ethernet and Fast Ethernet hosts to a DFE-2600 series hub stack, without any rewiring required when a host is upgraded from 10Mbps to 100Mbps.

The DFE-2600 series hubs, available in 16-port and 24-port models, can be stacked with up to five hubs in a stack. A stack of five 24-port hubs gives a total of 120 Ethernet or Fast Ethernet ports. A DFE-2600 series hub stack

operates as a Class II Fast Ethernet repeater, allowing it to be linked to another Class II Fast Ethernet stack in the same collision domain.

In the basic configuration, the 10Mbps and 100Mbps segments are separate and do not intercommunicate. An optional DFE-260S switch module (included with the DFE-2616x, DFE-2624x, DFE-2616ix, and DFE-2624ix) can be installed in any hub in the stack, making it possible to transparently bridge between the 10Mbps and 100Mbps segments. In a managed hub stack, more than one DFE-260S module can be used to provide redundancy if the two modules are both in the primary master hub segment..

Other add-in modules are also available, providing switched 100BASE-TX, or switched 100BASE-FX connections. DFE-2600 series hubs each have two slots for accepting slide-in modules.

Product Features

The list below highlights the features and specifications of the DFE-2600 series hubs.

- ◆ Compatible with the IEEE 802.3 10BASE-T Ethernet and 802.3u 100BASE-TX Fast Ethernet industry standards for interoperability with other Ethernet/Fast Ethernet network devices.
- ◆ Ethernet connections support Category 3 or better twisted-pair cables.
- ◆ Fast Ethernet connections support both shielded twisted pair and Category 5 unshielded twisted-pair cables.
- ◆ Fast Ethernet connections support a maximum distance of 100 meters from end-station to hub, and a total network diameter of 205 meters.

-
- ◆ Sixteen (DFE-2616, DFE-2616x, DFE-2616i, DFE-2616ix) or twenty-four (DFE-2624, DFE-2624x, DFE-2624i, DFE-2624ix) NWay RJ-45 ports for connecting stations to the network.
 - ◆ Full hub stack and network management provided via an SNMP management agent (DFE-2616i, DFE-2616ix, DFE-2624i, DFE-2624ix).
 - ◆ An optional slide-in switch module allows bridging between 10Mbps and 100Mbps segments. Only one switch module is needed per stack, but managed hub stacks can make use of additional switch modules for redundancy.
 - ◆ LED indicators for power, collisions, link, network activity, partitioning status, disable, operating speed (10 or 100Mbps) and network utilization.
 - ◆ Digital hub ID number front panel display.
 - ◆ Auto-partition protection.
 - ◆ Data collision detection and handling.
 - ◆ Preamble regeneration, signal retiming.
 - ◆ Two proprietary daisy-chain ports for cascading up to five hubs to form one logical hub; management provided via a master hub.
 - ◆ Standby backup master capability when two master model hubs are present within a single stack.
 - ◆ Uplink port allows easy linking of two Fast Ethernet hub stacks to further expand your network.
 - ◆ Standard-size (19", 1.25U height), rack mountable
 - ◆ Built-in, removable power supply, replaceable without opening the hub. Power supply is easily removed and replaced. Automatic volt-

age selection (100V to 240V, 50 or 60Hz) without fuses to change or a voltage switch to set.

- ◆ Optional slide-in modules: Switch, 100BASE-TX, and 100BASE-FX (see Chapter 4 : *Making Connections*).

Dual-Speed Ethernet Hub Technology Overview

Dual-speed Ethernet hubs have been developed to make it simpler to plan networks containing both 10Mbps Ethernet and 100Mbps Fast Ethernet technologies, especially when network hosts are being gradually migrated to new Fast Ethernet connections.

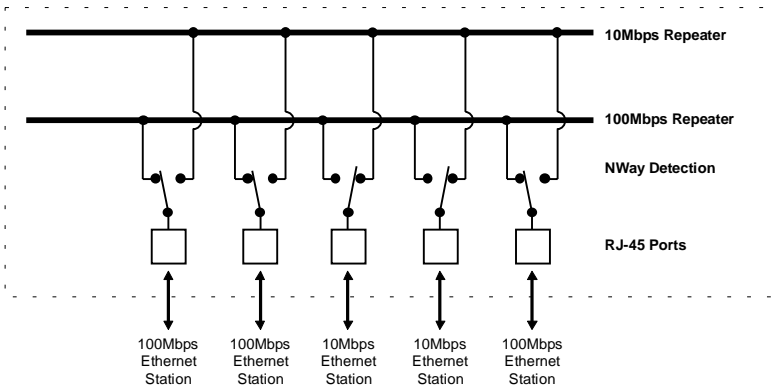

A dual-speed hub is actually two repeaters in one enclosure. The 10Mbps repeater receives Ethernet transmissions from any of its ports, and retransmits them to all other ports operating at 10Mbps. Similarly, the 100Mbps repeater retransmits Fast Ethernet transmissions from ports operating at 100Mbps to all other ports operating at the same speed.

If there is a DFE-260S module, or a DFE-2616x, DFE-2616ix, DFE-2624x or DFE-2624ix hub present in the stack, then the switch module serves as a bridge between the two independent segments.

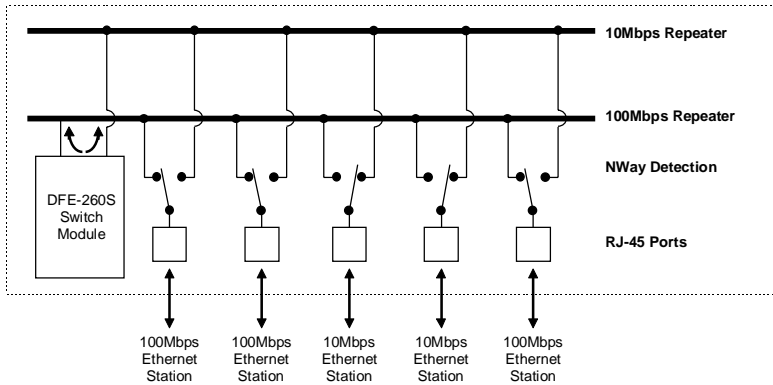

100BASE-TX Technology Overview

100Mbps Fast Ethernet Introduction

Computers today have become increasingly powerful, with the capability to accommodate very sophisticated uses such as multimedia applications, video-conferencing, and CAD/CAM. To utilize these technologically advanced applications more efficiently, there is also a growing demand for faster networks that can handle heavy network traffic.

Recognizing this need for greater bandwidth and lower latency, a variety of technologies such as FDDI, ATM, and Fast Ethernet (100Mbps) have been adopted by many vendors. Fast Ethernet technology stands out as the most inexpensive and smoothest migration path for existing 10Mbps Ethernet users in part because it doesn't require a protocol translation when sharing data with 10Mbps Ethernet.

Fast Ethernet is a relatively new standard specified by the IEEE 802.3 LAN committee. It is an extension of the 10Mbps Ethernet standard with the ability to transmit and receive data at 100Mbps, while maintaining the CSMA/CD Ethernet protocol. Since Fast Ethernet is compatible with all 10Mbps Ethernet environments, it provides a straightforward upgrade without wasting the company's existing investment in hardware, software, and trained personnel.

Cables and Connectors

Category 5 unshielded twisted-pair (UTP) cables and shielded twisted-pair (STP) cables are both supported. Category 5 UTP cable uses the same RJ-45 connector used with 10BASE-T, wired in the same configuration.

Topology

A Fast Ethernet workgroup is configured in a star topology and is built around a maximum of two repeaters. Each workgroup forms a separate LAN (also known as a segment or collision domain), and these workgroups can be easily interconnected through switches, bridges, or routers to form one LAN large enough to encompass a high-rise building or campus environment. Recent innovations in LAN hub technology such as stackable hubs, coupled with the decreasing cost of switches, bridges, and routers, allow the design of low-cost, efficient Fast Ethernet workgroups and enterprise LANs.

The following factors strongly influence the architecture of Fast Ethernet networks:

- The EIA/TIA 568 Wiring Standard imposes a 100 meter limit on horizontal runs of twisted-pair cables; that is, connections from the wiring closet to the end-station.
- Fast Ethernet's increased operational speed reduces the maximum distance between all elements of the LAN (see below).

-
- The EIA/TIA 568 Wiring Standard does not support the use of coaxial cables for horizontal wiring.

Network Diameter

Network diameter, which is the distance between two end-stations in the same collision domain, is the primary difference between traditional Ethernet and Fast Ethernet. Due to the increased speed in Fast Ethernet and adherence to the EIA/TIA 568 wiring rules, the network diameter of a Fast Ethernet collision domain is limited to 205 meters; in contrast, the maximum 10BASE-T Ethernet collision domain diameter can be up to 500 meters.

Hub Types

Unlike 10BASE-T hubs which are all functionally identical, Fast Ethernet hubs are divided into two distinct types: Class I and Class II. A Class I hub repeats all incoming signals on one port to the other ports by first translating them to digital signals and then retranslating them back to line signals. These translations are necessary when connecting various network media to the same collision domain, such as when combining two wire-pair 100BASE-TX media with four wire-pair 100BASE-T4 media. Only one Class I hub can exist within the same collision domain, thus this type of hub cannot be directly interlinked. A Class II repeater, on the other hand, immediately repeats all incoming line signals on one port to the other ports; no translations are performed. This type of hub connects identical media within the same collision domain; for example, TX to TX. At most, two Class II hubs can exist within the same collision domain.

As mentioned earlier, stackable Class II hubs can be used to increase the number of available nodes in a collision domain. An entire hub stack counts as a single repeater. DFE-2600 series hubs are Class II devices.

2

UNPACKING AND SETUP

This chapter provides information on the unpacking and initial installation of your hub stack.

Unpacking

Open the shipping carton of your hub and carefully unpack the contents. The carton should contain the following items:

- ◆ One dual-speed stackable hub
- ◆ One AC power cord, suitable for your area's electrical power connections
- ◆ One daisy-chain cable
- ◆ Four rubber feet to be used for shock cushioning
- ◆ Six screws and two mounting brackets
- ◆ D-View module diskette (master models only)
- ◆ This *User's Guide*

Inspect the hub and all accompanying items. If any item is damaged or missing, report the problem to your D-Link dealer.

Identifying External Components

This section identifies all the major external components of the hub. Both the front and rear panels are shown, followed by a description of each panel feature. The indicator panel is described in detail in the next chapter.

Front Panel

DFE-2624i / DFE-2624ix Front Panel

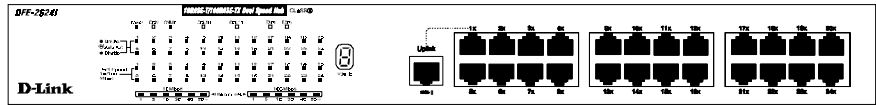

DFE-2624 / DFE-2624x Front Panel

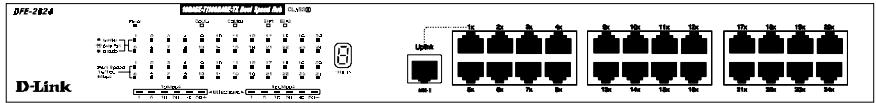

DFE-2616i / DFE-2616ix Front Panel

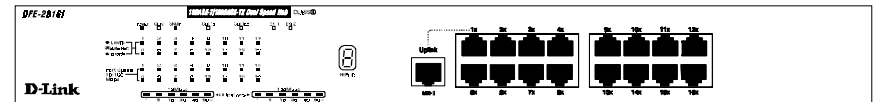

DFE-2616 / DFE-2616x Front Panel

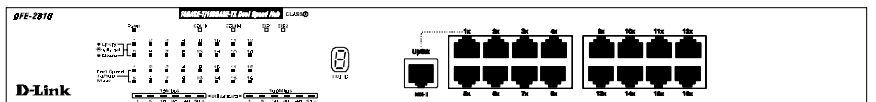

◆ LED Indicator Panel

Refer to the next chapter, *Understanding Indicators*, for detailed information about each of the hub's LED indicators.

◆ Twisted-Pair Ports

Use any of these ports to connect stations to the hub. The ports are MDI-X Nway ports, which means you can use ordinary straight-through twisted-pair cable to connect the hub to PCs, workstations, or servers through these ports, and the speed of the connection will be detected automatically. If you need to connect to another device with MDI-X ports such as another hub or an Ethernet switch, you should use a crossover cable, or connect using the Uplink port (described below). For more information about crossover connection, see the *Crossover Cables* section on page 74.

◆ Uplink Port

The Uplink port is an MDI port, which means you can connect the hub (or hub stack) to another device with MDI-X ports using an ordinary straight-through cable, making a crossover cable unnecessary.

Port 1 and the Uplink port are the same logical port, except their pinouts are different. **Do not use both Port 1 and the Uplink port at the same time.**

Rear Panel

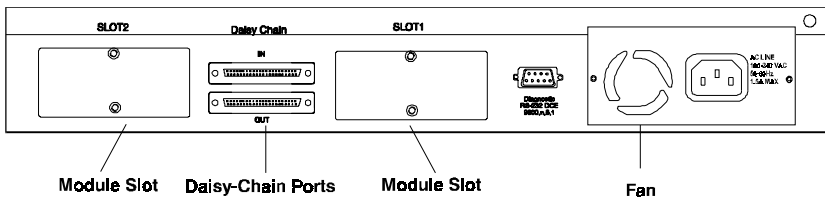

(Note that the figure shows the rear panel for master models.)

◆ **Module Slots**

Used to install module options for various kinds of additional connections, as well as the DFE-260S 10Mbps/100Mbps bridge module. (In the DFE-2616x, DFE-2616ix, DFE-2624x and DFE-2624ix, module slot 1 is already occupied by the switch module which is standard on these models.)

◆ **Daisy-Chain IN Port**

When cascading a set of D-Link's stackable dual-speed hubs, this port should be connected to the Daisy-Chain OUT port of the previous hub in the stack (usually placed immediately above it). A cascade of five hubs can be created in this way. The first and last hubs in the stack use only one of the daisy-chain ports, while the others use both.

◆ **Daisy-Chain OUT Port**

Works in conjunction with the Daisy-Chain IN Port (see above). Connect this port to the Daisy-Chain IN Port of the next hub in the stack (usually placed immediately below it), using the enclosed daisy-chain cable.

◆ **Diagnostic (Console) Port -- Master Models Only**

This 9-pin serial connector is used for connecting a console to the DFE-2600 series master hubs for out-of-band management of this particular hub or the entire stack.

◆ **Fan**

Provides air circulation and heat dissipation. Be sure to leave adequate space at the rear of the unit for proper ventilation.

◆ **AC Power Connector**

For the power cord.

Installing the Hub

Installation

The site where you install the hub stack may greatly affect its performance. When installing, consider the following pointers:

- ◆ Install the hub stack in a fairly cool and dry place. See Appendix D, *Specifications*, for the acceptable temperature and humidity operating ranges.
- ◆ Install the hub stack in a site free from strong electromagnetic field generators (such as motors), vibration, dust, and direct exposure to sunlight.
- ◆ Leave at least 10cm of space at the front and rear of the hub for ventilation.
- ◆ Install the hub on a sturdy, level surface that can support its weight, or in an EIA standard-size equipment rack. For information on rack installation, see the next section, *Rack Mounting*.

When installing the hub stack on a level surface, attach the rubber feet to the bottom of each device. The rubber feet cushion the hub and protect the hub case from scratching.

Rack Mounting

The hub can be mounted in an EIA standard-size, 19-inch rack, which can be placed in a wiring closet with other equipment. Attach the mounting brackets at the hub's front panel (one on each side), and secure them with the provided screws.

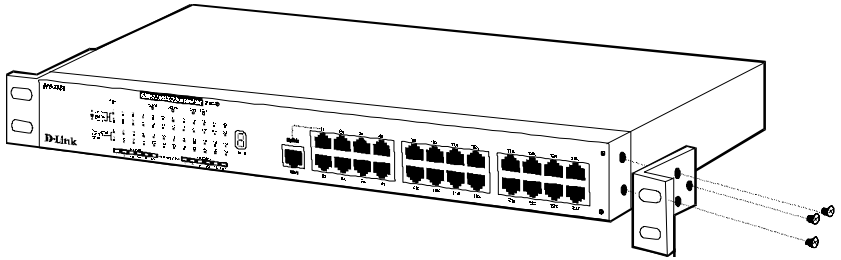

Then, use screws provided with the equipment rack to mount each hub in the rack.

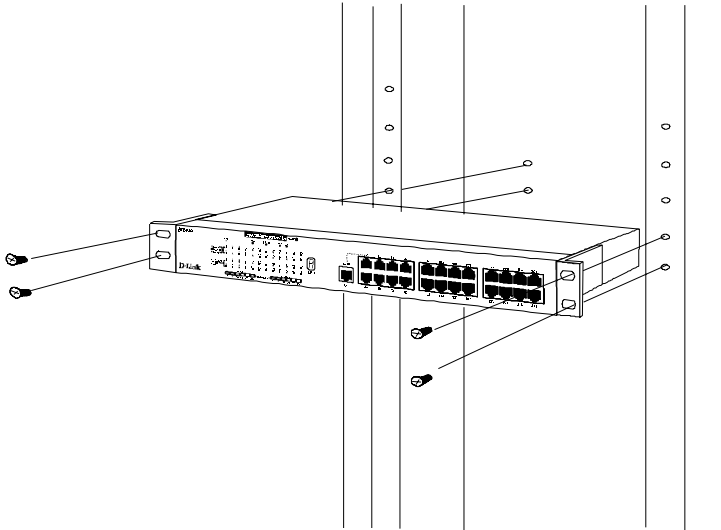

Replacing the Power Supply

The hub comes with a removable power supply for easy replacement. In the unlikely event that the power supply fails or is damaged, follow the steps below to replace it:

1. Disconnect the power cord from the AC outlet.
2. Disconnect the power cord from its connector on the rear of the hub.
3. Using a Phillips screwdriver, remove the screws securing the power supply to release the unit.
4. Remove the power supply by sliding it out the rear of the chassis. Do not plug in the power supply when it is outside the chassis! Doing so could cause personal injury or damage to the power supply.
5. Slide the replacement power supply into the chassis, engaging the connector carefully.
6. Attach the power cord to the connector of the power supply and connect the other end of the power cord to the AC supply source.

3

UNDERSTANDING INDICATORS

Before connecting network devices to the hub, take a few minutes to look over this section and familiarize yourself with the front panel LED indicators of your dual-speed hub, depicted below.

DFE-2624i / DFE-2624ix Indicator Panel

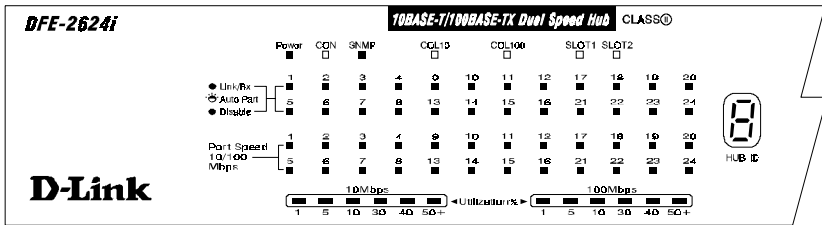

DFE-2616i / DFE-2616ix Indicator Panel

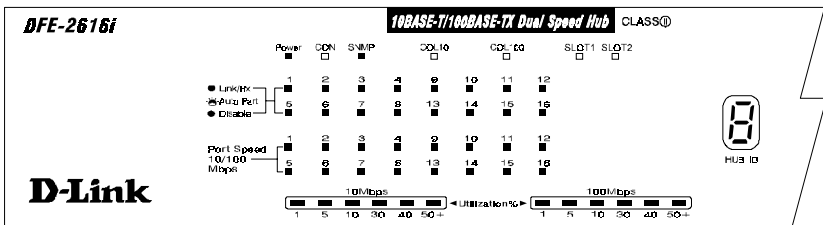

DFE-2624 / DFE-2624x Indicator Panel

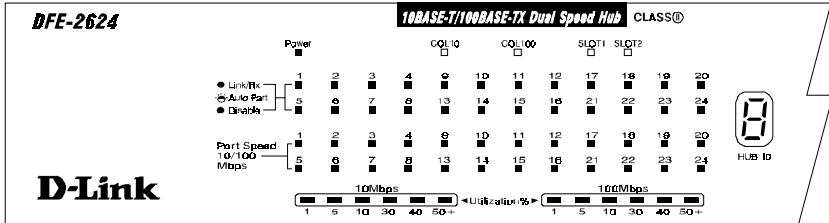

DFE-2616 / DFE-2616x Indicator Panel

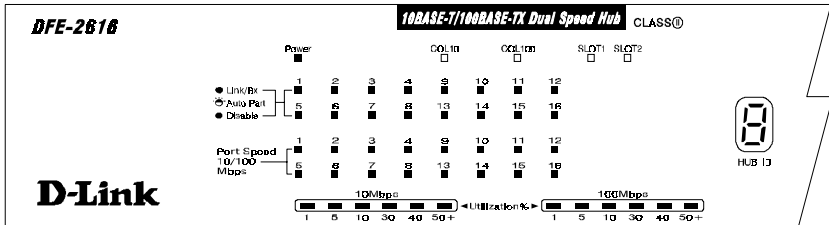

Hub State Indicators

◆ Power Indicator

This indicator lights green when the hub is receiving power; otherwise, it is off.

◆ Collision Indicators (COL10 and COL100)

These indicators indicate data collisions on the respective 10Mbps Ethernet or 100Mbps Fast Ethernet segments of the hub. (If several hubs are stacked or linked together, all of them should detect and indicate the same collision, since collisions span the entire network segment.) Whenever a collision is detected, the respective COL indicator will briefly blink amber.

◆ **Segment Utilization % (10Mbps and 100Mbps)**

The utilization bar graphs provide a quick reference on the current traffic load relative to the total available 10Mbps or 100Mbps network bandwidth. The graphs display a measure of the percentage of bandwidth in use on the respective network segment. All data packets are counted, whether valid or not.

◆ **Hub ID Indicator**

The Hub ID readout shows the ID (group) number of the hub within the hub stack. The first time a hub is powered on within a hub stack, the master hub in the stack assigns that hub an available ID number which is then added to each hub's factory serial number (encoded on an EEPROM memory chip). The hub ID is then permanently assigned.

In an unmanaged stack (all slave models), all IDs will read "0" and no permanent ID assignment is made. In a stack with a master (intelligent) model, the master hub will detect the other hubs in the stack and automatically assign ID numbers which are then permanently saved by each hub.

Module Indicators (SLOT1 & 2)

The two module indicators, SLOT1 and SLOT2, indicate a good link to a module installed in the respective slot. For the DFE-260S switch module the indicator will come on when the module is installed. For the DFE-260FX and DFE-260TX modules, the slot link indicator should light whenever the module is installed and there is a valid link.

Port State Indicators

There is one port state indicator for each of the twisted-pair ports on the hub. Each port's LED status indicator reports the port's link and activity status, and shows whether or not the port has been partitioned.

The following describes each indicator and the meaning of each condition:

◆ **Link (green)**

The indicator of a port lights green when the port is connected to a powered Ethernet or Fast Ethernet station. If the station to which the hub is connected is powered off, or if there is a problem with the link, the LED will remain off.

◆ **Receive (blinking green)**

When information is received on a port, its indicator will blink off briefly. Upon reception, the data will be transmitted to all other connected ports.

◆ **Auto-partition (blinking amber)**

The indicator of a port blinks amber when the port is automatically partitioned due to an abnormal network condition.

The hub will temporarily partition a port when too many line errors or too many collisions are detected on the port. While the segment is automatically partitioned, the port will be isolated from the rest of the network segment. When the problem is corrected or a valid data packet is received through the port, the port is automatically reconnected.

◆ **Disabled (steady amber)**

The indicator of a port is orange when the port has been manually disabled. No packet transmission or reception can occur on the port.

If there is a DFE-2616i, DFE-2616ix, DFE-2624i, or DFE-2624ix master hub in the stack, then ports can be manually disabled and enabled via the on-board console interface or via an SNMP-based network management program such as D-Link's D-View Network Management Program. You can choose to partition a port even when there is nothing wrong with it, for example, to prevent a certain device from accessing the network.

SNMP Indicator

(Master models only.)

This indicator comes on when the SNMP agent of a DFE-2600 series master hub is active. In a stack with both a Primary and a Backup Master, the SNMP LED of the Primary master will be lit and will flash to indicate SNMP activity. The SNMP LED of the Backup Master will remain off at all times.

Port Speed Indicators

There is also a port speed indicator for each of the twisted-pair ports on the hub. A port's speed indicator should light green when a 100BASE-TX device is connected to the port, and remain dark if the port is unconnected or if a 10BASE-T device is connected.

Console Port Indicator (CON)

(Master models only.)

This indicator lights continuously under the following two conditions:

1. A good connection has been established with a console (for example, a PC or other computer). The diagnostic port of a DFE-2600 series master hub must be connected to the console's RS-232 serial port using a normal serial cable.

OR

2. The console computer is on-line and connected to the on-board console program either through terminal emulation or a TELNET session.

Refer to Chapter 4, *Making Connections*, for directions on establishing a connection with the diagnostic port, and Chapter 5, *Master Hub Setup and Management*, for information about how to use the console interface.

4

MAKING CONNECTIONS

This chapter discusses how to make connections to the hub's twisted-pair and console ports, cascading hubs to create a stack, and linking with other hubs (or hub stacks).

Hub Cascading/Building a Stack

You can stack up to five hubs using the daisy-chain ports to form one logical hub. In this configuration, the interconnected hubs constitute a single logical unit, providing a maximum of 120 twisted-pair ports.

Use the provided daisy-chain cable to connect the Daisy-Chain OUT port on the rear panel of one hub to the Daisy-Chain IN port on the hub below it, as shown in the figure below. Repeat this procedure for each hub to be included in the stack.

Each time a new hub is added to the stack, all hub IDs will temporarily revert to 0, indicating a system reset. After the reset, the hub IDs should return to their previous values.

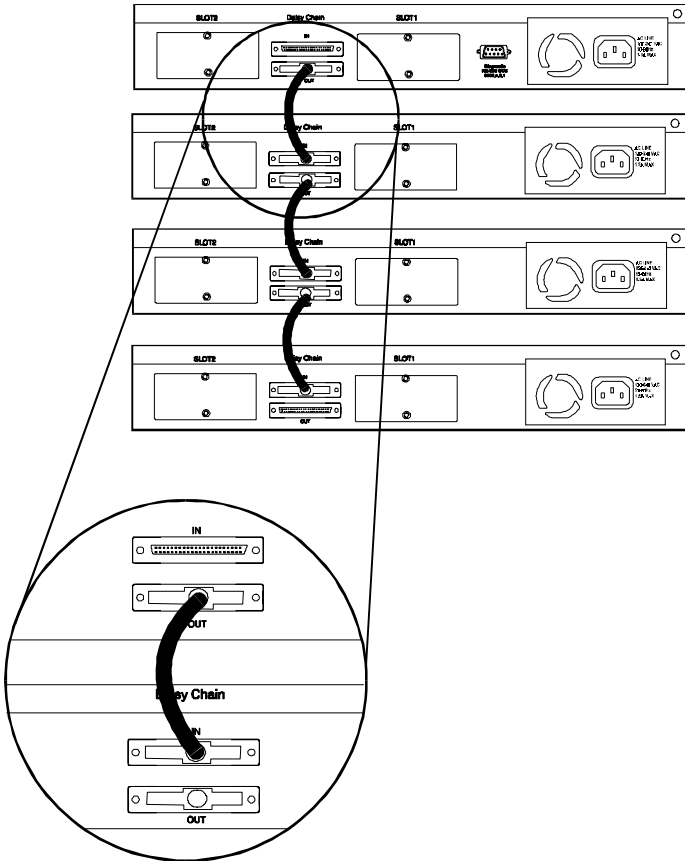

Hubs should not be added to the stack or removed from the stack while the power is on to any hub in the stack.

Note: Always turn off power to the entire stack before adding or removing hubs.

Connectivity Rules

Ethernet (10Mbps) networks have the following connectivity rules:

- ◆ The maximum length of a twisted-pair cable segment is 100 meters. Cabling should be Category 3 or better.
- ◆ Between any two end-stations in a collision domain, there may be up to five cable segments and four intermediate repeaters (hubs, hub stacks, or other repeaters).
- ◆ If there is a path between any two end-stations containing five segments and four repeaters, then at least two of the cable segments must be point-to-point link segments (e.g., 10BASE-T or 10BASE-FL), while the remaining segments may be populated (mixing) segments (e.g., 10BASE-2 or 10BASE-5).

Fast Ethernet (100Mbps) networks have the following connectivity rules:

- ◆ The maximum length of a twisted-pair segment (that is, the distance between a port in the hub to a single-address network device such as a PC, server, or Ethernet switch) is 100 meters. Cabling and other wiring should be certified as Category 5 UTP or shielded twisted-pair(STP).
- ◆ The maximum diameter in a collision domain is about 205 meters using two Class II hubs (or hub stacks).
- ◆ Between any two end-stations in a collision domain, there may be up to three cable segments and two Class II hubs or hub stacks.

The Diagnostic Port

The diagnostic port on the rear panel of the master hub is used to establish a connection with a device to allow out-of-band management of the DFE-2600 series hubs stacked with it. The console device connected to the diagnostic port can be a terminal (or a computer running terminal-emulating software) or a PC running TCP/IP TELNET.

Diagnostic Port Connection

The diagnostic port is an RS-232 DCE interface. To establish a physical line connection with an RS-232 serial port (DTE) on a PC acting as a console, all you need is a straight serial cable, as shown in below. Note that a DCE-to-DTE connection requires a straight serial cable, not a null-modem cable.

You can use the diagnostic port on a DFE-2600 series master hub to connect a VT100-compatible terminal or a computer running an ordinary terminal emulation program (such as the terminal program included with the Windows operating system). In all cases, your terminal parameters will need to be set to:

- ◆ VT-100/ANSI compatible,
- ◆ Arrow keys enabled,
- ◆ 9600 baud,
- ◆ 8 data bits,
- ◆ No parity,
- ◆ 1 stop bit.

You can also access the same functions over a TELNET link. Once you have set an IP address for your hub (see the beginning of this chapter), you

can use a TELNET program (in a VT-100 compatible terminal mode) to access and control the hub. All of the screens are for the most part identical, whether accessed from the diagnostic port or from TELNET.

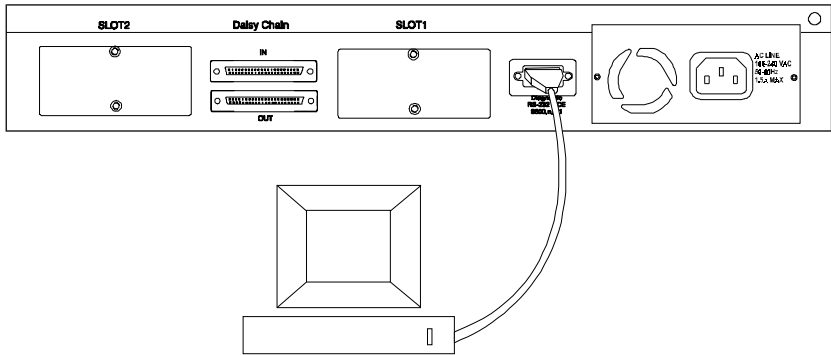

A console device can manage a DFE-2600 series master hub operating in a stack master or stand-alone master role. Use the on-board console program for out-of-band management or D-View (included with DFE-2600 series master hubs) for in-band or out-of-band management. Other SNMP management software will also work fine.

A console device can only manage a DFE-2600 series hub if it is cascaded to a DFE-2600 series master hub. Use either the on-board console program or an SNMP-based network management program to manage the stack.

Hub to End-Station Connection

After installing the hub properly, it can support up to sixteen (DFE-2616, DFE-2616x, DFE-2616i, DFE-2616ix) or twenty-four (DFE-2624, DFE-2624x, DFE-2624i, DFE-2624ix) end-station connections. Fast Ethernet

connections require either a Category 5 UTP cable or an STP cable. These cables can be up to 100 meters long.

Each Ethernet connection requires a Category 3 or better UTP cable. It is recommended that you use Category 5 cabling for all connections, in order to make it easier to transition all stations to 100Mbps.

You can connect any combination of PCs, servers, and other single-address network devices to the twisted-pair ports using straight-through twisted-pair cables. These cables should not be crossed over. The following figure illustrates the pin assignments for a straight-through cable:

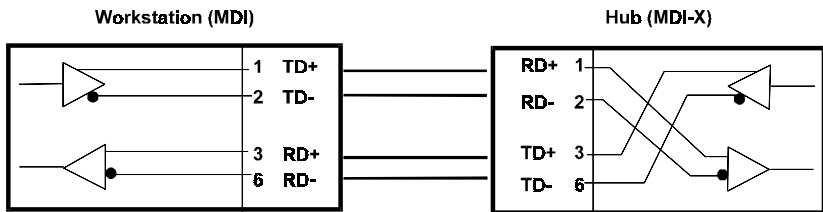

When connecting a PC or a server, the system being connected should have an Ethernet or Fast Ethernet network interface card with a twisted-pair port. The following figure shows a typical connection between the hub and end-stations:

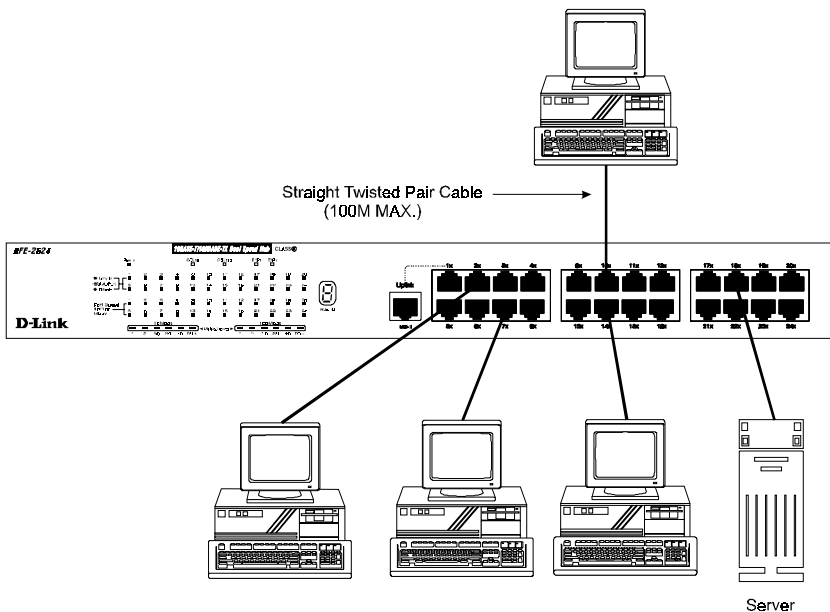

Hub-to-Hub Uplink

You can link two hubs or hub stacks to each other using any of the twisted-pair ports or the Uplink port. Linking hubs using ordinary twisted-pair ports requires crossover twisted-pair cables; linking using one ordinary twisted-pair port and the Uplink port requires an ordinary straight-through twisted-pair cable. The Uplink port is shared with Port 1, and you should not use both Port 1 and the Uplink port at the same time.

When connecting two hubs or hub stacks in this fashion, the maximum distance between any two end-stations in a collision domain is 205 meters. If each link between the hub and an end-station is 100 meters, then the hub-to-hub connection is limited to 5 meters. However, if the longest hub-to-end-station connection is less than 100 meters, then the hub-to-hub connec-

tion can be up to 100 meters long as long as the 205-meter total network diameter rule is followed.

The following table describes different methods of linking hubs (or hub stacks):

HUB PORT USED	DEVICE	PORT TYPE	CABLE TO USE
Normal	Switch or Hub	Non-Uplink	Crossover (X)
		<i>Uplink</i>	Straight-Through ()
	Server (or PC)	Straight-Through ()	
<i>Uplink</i>	Switch or Hub	Non-Uplink	Straight-Through ()
		<i>Uplink</i>	Crossover (X)
	Server (or PC)	Crossover (X)	

A crossover cable is a straight-through twisted-pair cable in which the wires have been crossed. The figure below shows the pin assignments for an Ethernet or Fast Ethernet crossover cable:

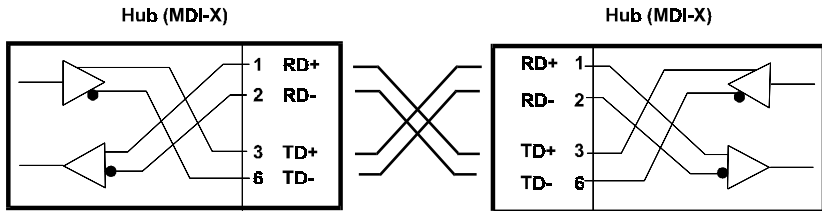

NOTE: *The first twisted-pair port (Port 1) is logically shared with the Uplink port. If you connect a hub to the Uplink port, then do not use Port 1.*

Optional Module Connections

There are three optional modules that may be added to any of the DFE-2600 series hubs. Each hub can accommodate two modules. Each of the modules offers a different additional network interface that allows for greater flexibility in how these hubs may be used in a network.

The sections that follow provide a brief overview of the module and basic instructions on any settings and indicators.

Module Installation

The installation procedure for each module is the same. Additional information about each module is provided below.

To install any of the modules:

1. Locate one of the module slots in the hub's rear panel. (Note that the DFE-260S module can only be installed in Slot 1 – the center slot.)
2. Using a screwdriver, undo the two screws and remove the dust cover on the module slot.
3. Holding the module component-side up and connector-side in, gently slide the module along the guides and seat it in the internal connector.
4. Using a screwdriver, replace the two screws and tighten until snug.

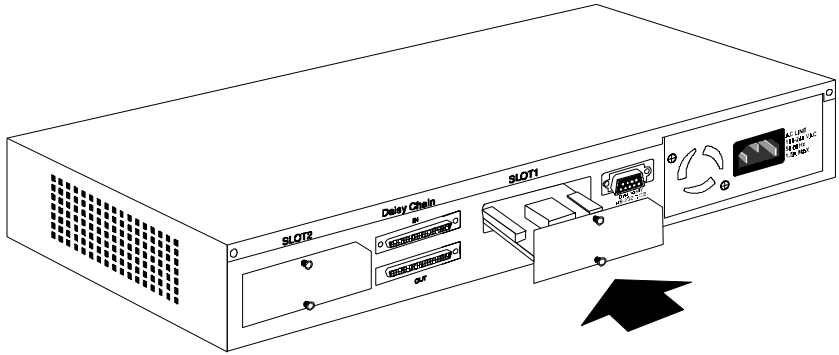

We recommend that you retain the dust cover in case you need to remove the module for an extended period sometime in the future.

Switch Module (DFE-260S)

The DFE-260S switch module is used to allow interconnection between the 10Mbps and 100Mbps segments in the hub or hub stack. Each hub stack should have one DFE-260S module (such as the one included in the DFE-2616x, DFE-2616ix, DFE-2624x or DFE-2624ix) to allow 10Mbps and 100Mbps stations to intercommunicate. Note that the DFE-260S module can only be installed in Slot 1 – the center slot. Also the presence of switch modules and their operational status can be viewed on the “Network Monitoring – Bridge Information” screen.

NOTE: *In a stack containing a DFE-2616i, DFE-2624i, DFE-2616ix, or DFE-2624ix intelligent master hub, more than one DFE-260S switch module may be used to provide increased reliability through redundancy. The Spanning Tree Protocol implemented in the management agent can control the DFE-260S modules to provide link redundancy and prevent network loops but only when multiple*

modules are installed in hubs on the primary master segment.

Fiber Optic Module (DFE-260FX)

The Fiber Optic module provides a standard Fast Ethernet 100BASE-FX fiber optic connector. A fiber optic connection of this kind is particularly useful for creating a link between two DFE-2600 series hub stacks, placing them in separate collision domains. A link of this sort eliminates the need for an external switch to divide stacks into separate domains. Dividing the stacks into separate collision domains overcomes the Fast Ethernet two-repeater limitation, and effectively doubles overall bandwidth.

The Fiber Optic module includes the following LED indicators:

- **Power/Tx**—This LED is lit when the hub is on and blinks when packets are being transmitted by the module.
- **Link/Rx**—This LED is lit when the fiber optic ports are properly connected to a powered-on device and blinks when packets are being received by the module.

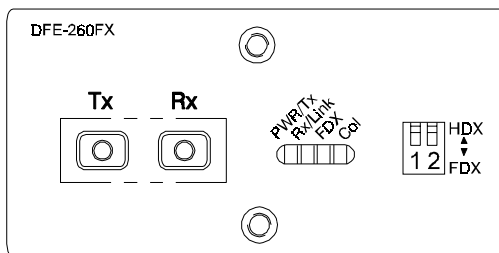

- **Collision**—This LED blinks when there are packet collisions on the fiber optic link.

- **FDX**—This LED is lit when the fiber optic port is set for Full Duplex transmit and receive. When the LED is off, the fiber optic port is in Half Duplex mode.

The duplex mode DIP switch allows you to set the fiber optic lines to Full Duplex mode operation. Only the right-hand switch (number 2) is active. Use it to set the duplex mode.

Fast Ethernet Module (DFE-260TX)

The Fast Ethernet module provides one additional twisted-pair Fast Ethernet connection. A twisted-pair connection of this kind is particularly useful for creating a link between two DFE-2600 series hub stacks, placing them in separate collision domains. A link of this sort eliminates the need for an external switch to divide stacks into separate domains. Dividing the stacks into separate collision domains overcomes the Fast Ethernet two-repeater limitation, and effectively doubles overall bandwidth.

The Fast Ethernet module uses a MDI-X connector (not a straight MDI) and, therefore, a crossover cable must be used when connecting the module to another module (and under most other circumstances). See Appendix A for pinout information.

The Fast Ethernet module includes the following LED indicators:

- **Power/Tx**—This LED is lit when the hub is on and blinks when packets are being transmitted by the module.
- **Link/Rx**—This LED is lit when the port is properly connected to a powered-on device and blinks when packets are being received by the module.

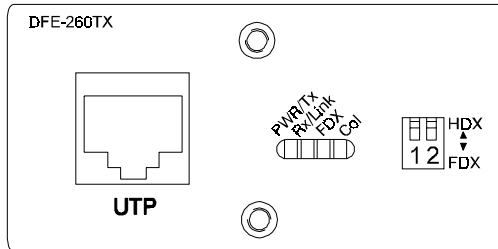

- **Collision**—This LED blinks when there are packet collisions on the module line.
- **FDX**—This LED is lit when the port is set for Full Duplex transmit and receive. When the LED is off, the port is in Half Duplex mode.

NOTE: *Because the DFE-260TX module's port is an NWay UTP port, once the hub is powered on, it will automatically detect the duplex and speed modes of any device connected to it. The DIP switch may then be set to force the duplex mode into a particular state. After the DIP switch is set, the DFE-260TX will only operate at 100Mbps in the duplex mode selected.*

The duplex mode DIP switch allows you to set the port to Full Duplex mode operation. Only the right-hand switch (number 2) is active. Use the DIP switch to set the duplex mode.

5

MASTER HUB SETUP AND MANAGEMENT

The DFE-2616i, DFE-2616ix, DFE-2624i, and DFE-2624ix master hubs (hereafter and elsewhere referred to as, “DFE-2600 series master hubs”) provide an on-board console program that allows you to set up and control all DFE-2600 hubs stacked with it. This program can be accessed either with an ordinary terminal (or terminal emulator) or over the network using the TCP/IP TELNET protocol. You can use this program to perform many basic network management functions.

The console program also allows you to prepare the hub for management using D-View or another SNMP-based network management system. This chapter describes how to use the console program to access the hub, change its settings, and monitor its operation.

Note that if you want to manage the hub in-band you need to follow the instructions in the first section of this chapter to prepare the hub for in-band management. If you need information about connecting a console device to the diagnostic port for out-of-band management, see the relevant sections of Chapter 4.

Navigation and Conventions

This section describes how to navigate the master hub management software and the conventions used in that software.

Navigation

The Tab keys move the cursor from field to field. Note that they are uni-directional (i.e., Shift-Tab is not a functional combination). Up and Down arrow keys allow cursor movement between some fields.

The Spacebar is a toggle switch for all variables that can be changed but wherein possible values are preset.

The Delete and Backspace keys remove entered text as in most software packages.

Pressing Ctrl-r refreshes the current screen.

Screen Conventions

Fields that cannot be changed are preceded by a colon (":").

Toggle changed fields are surrounded by angle brackets <>.

Variables with values that must be keyed-in are surrounded by square brackets [].

Uppercase letters are reserved for command items such as SAVE or LOGOFF. Highlighting the item and pressing Enter activates the command.

Note: Both the navigation and screen conventions information can be obtained under HELP in the system management software.

In-Band Setup Instructions

This section describes how to setup the hub for in-band management.

Getting Started

Physically install and cascade the hubs and power on the hub stack according to the directions in other parts of this manual. At this point, the hub stack is ready for use as an ordinary unmanaged repeater.

The master hubs in the series come without IP addresses assigned (IP = 0.0.0.0). Without a valid IP address, the master hub will show a POST error indication and repeatedly restart itself once every minute or so. If you want to manage your hub using a network management system, you will have to assign an IP address to the hub. There are two different ways to configure the hub with a new address, as described below.

Assigning an IP Address Using BOOTP

If your Fast Ethernet network has a BOOTP (BOOTstrap Protocol) server, you need only add the hub's Ethernet (MAC) address (which is printed on a sticker on the bottom of the hub, or which you can determine using the master hub console interface), IP address, subnet mask, and boot filename to your BOOTP server's configuration tables. The boot filename field of the hub's BOOTP configuration should contain the filename of a DFE-2600 series master hub boot configuration file accessible on your local TFTP (Trivial File Transfer Protocol) server. This file can be empty. For more detailed information about the boot configuration file contents, see *Appendix C : Boot Configuration File* of this manual.

Assigning an IP Address Using the Diagnostic Port

To assign an IP address manually,

1. Connect a VT-100 compatible terminal or a personal computer running a VT-100 compatible terminal emulation program to the DB-9 console port at the rear of the master hub. The cable should be an

ordinary RS-232C cable. The terminal communications parameters should be set to 9600bps, 8 bits, no parity, and 1 stop bit.

2. As the hub begins its boot process, hit Control-C to enter the PROM System Menu.
3. Choose TCP/IP Parameters Configuration, and enter a valid IP address, network mask, and (optional) gateway router IP address. Choose SAVE and press <Enter> to let the changes take effect, and then choose EXIT.
4. If you will not be using TFTP to download a hub configuration file, choose Software Update and toggle the Software Update Control to Disable using the Space Bar. Again, choose SAVE and then EXIT.
5. Choose Execute Bootstrap to restart the hub.

You are now ready to use your DFE-2600 series hub stack, and to manage it from a network management station on your network. See the *Stack Management User's Guide* for more information about how to manage the stack using the D-View Network Management Program.

Backup Master Function

Within a DFE-2600 series hub stack, in addition to a master hub for management purposes, a standby backup master can also be installed. If a hub stack has two master units, the master unit powered-on first or the unit which is higher in the stack will manage the stack and be designated the "Primary Master." Master hubs in the series include a built-in contention algorithm which determines which hub will manage the stack and which will operate in standby mode. If, during power-on, the two master hubs in the stack both attempt to initialize as the Primary Master, this collision will result in an automatic stack reset indicated by all hub ID numbers changing to 0 temporarily. If the currently managing hub fails or is powered-off, the standby master will take over management of the hub stack.

Segmenting Hubs

Switching hub technology has made it more common to segment local area networks into smaller pieces to reduce congestion. Segmenting makes it easier to balance network loads, since a smaller number compete for the bandwidth available.

A hub stack makes network management convenient, but too many stations on a single network segment may give slow response at peak network loads. Therefore, this hub series provides a way to segment hubs from the stack into their own collision domains. Segmenting hubs can be accomplished with a simple management command and does not require any hardware or wiring changes.

Though the hubs continue to be cascaded together and are managed as a single unit, each hub can either be a part of the collision domain of the rest of the stack, or can be separated into its own network segment. These separate segments can be bridged by connecting them through a compatible switching hub.

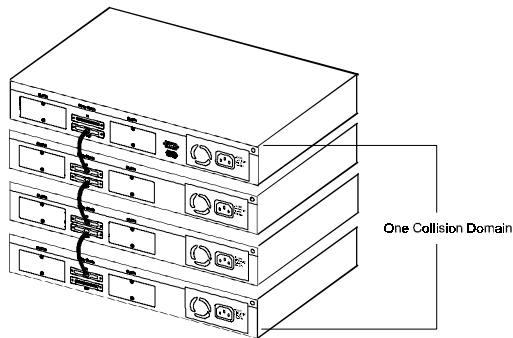

The figure above shows an unsegmented hub stack. All hubs in the stack are in the same collision domain because they are connected together through the daisy-chain ports.

The figure below shows a stack divided into three separate collision domains. Hubs three and four are isolated from the main segment (collision domain one) using the hub's segmentation capability, putting them into their own isolated collision domains two and three respectively. A switch, bridge or router can be used to connect the three collision domains so that traffic can pass between them, yet keeping them isolated to reduce congestion on each segment.

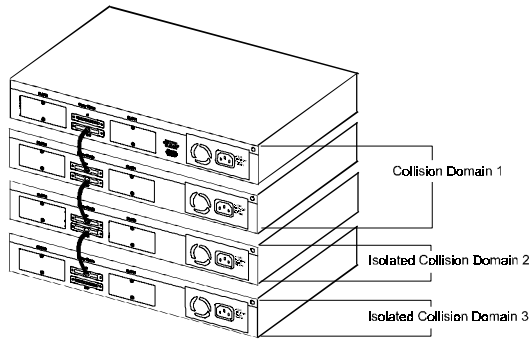

For information about segmenting hubs using the network management module for the hub, see the “Hub Stack Management: Controlling Hubs in the Hub Stack” section later in this chapter.

NOTE: *Hub segmentation is controlled by the master hub. When the master hub completes its initialization, it will restore any prior segmentation of the hubs. Therefore, if you are using a switch or bridge to join different segments, be sure to enable the IEEE 803.1d Spanning Tree Protocol to prevent temporary network loops*

Logging in to the Hub Console

The DFE-2600 series master hubs support user-based security that allows you to prevent unauthorized users from accessing the hub or changing its settings. This means that before you can access the functions of the hub, you will need to first log into the hub, providing a password. This section tells how to log onto the hub, and how to change your password.

Logging In

When you first connect to the hub, it will display the login screen:

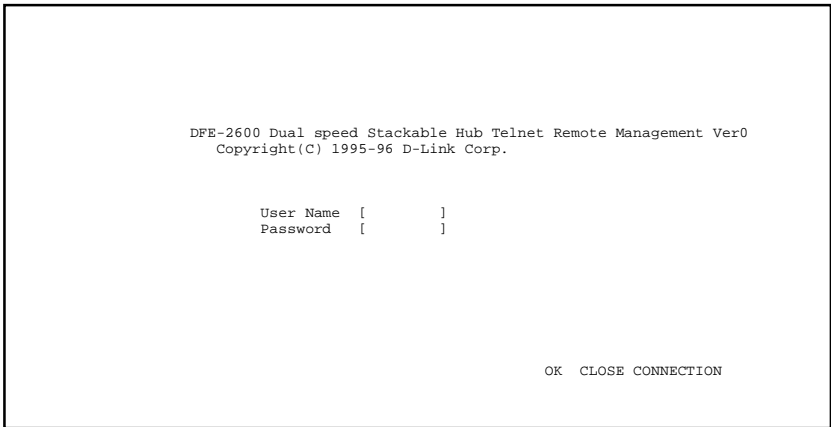

```
DFE-2600 Dual speed Stackable Hub Telnet Remote Management Ver0
Copyright(C) 1995-96 D-Link Corp.

User Name [      ]
Password  [      ]

OK  CLOSE CONNECTION
```

To log in, complete these steps:

1. Type in your user name and press <Enter>.
2. Type in your password and press <Enter>.
3. With the cursor on the OK selection, press <Enter>.

NOTE: *When the hub is shipped, the default user name is **D-Link**, and the default password is*

also **D-Link**. You will need to use this user name and password when you first set up your hub or if you use the Factory Reset NVRAM to Default Value menu selection. **Change this user name and password to protect the security of your hub.**

There are two levels of user privilege: *Super User* and *General User*. The default user (*D-Link*) has *Super User* privileges. Some functions available to *Super Users* are not available to *General Users*. The main menu below is the menu for *Super Users*:

```
DFE-2600 Stackable Hub - Main Menu

System Configuration
TCP/IP Parameters Configuration
Network Monitoring
Out-of-Band/Console Configuration
User Account Change
SNMP Trap Manager Configuration
SNMP Manager Configuration
System Reset
Software Update
Factory Reset NV-RAM to Default Value

LOGOFF
```

Changing Your Password

To change your user password, follow these steps:

- 1. Choose User Account Change** from the main menu.
- 2. Select Change Password.** The following screen will be displayed:

DFE-2600 Stackable Hub - User Account Change : Change Password

```
User Name      [      ]  
Old Password   [      ]  
  
New password   [      ]  
Confirm Password [      ]
```

HELP SAVE EXIT

3. Type in your user name and press <Enter>.
4. Type in your old password and press <Enter>.
5. Type in the new password you have chosen, and press <Enter>. Type in the same new password again in the next blank space to verify what you typed.
6. Choose **SAVE** to put the new password into effect.
7. Choose **EXIT** to exit this screen.

This method can also be used by a *Super User* to change another user's password.

Setting Up the Master Hub

This section describes how to set the hub's console parameters for the various management options it supports. Note that the hub can be managed in-band or out-of-band, and either through the built-in console program, or using an SNMP-management program such as D-View.

TCP/IP Settings

The hub needs to have an IP address assigned to it so that the network management system or TELNET client can communicate with it over the network. The TCP/IP Parameters Configuration Menu allows you to change the settings for the two different interfaces used by the hub: the internal Fast Ethernet interface used for in-band communication, and the SLIP interface used through the diagnostic port for out-of-band communication.

Note: if you need to set an IP address so that you can access the hub console through a network, see the first section of this chapter.

Saved changes to any of the fields on this menu take effect the next time the system is restarted. Fields that can be set include:

- ◆ **Interface.** This parameter displays the type of interface the hub will use for management communications.
- ◆ **IP Address.** This parameter determines the IP address used by the hub for receiving SNMP and TELNET messages. Should be of the form xxx.xxx.xxx.xxx, where each xxx is a number (represented in decimal) between 0 and 255. This address should be a unique address on the network assigned to you by a network administrator. The same IP address is shared by both the SLIP and Ethernet network interfaces.

- ◆ **Subnet Mask.** This parameter sets the subnet mask that determines the level of the subnet that the hub is on. Should be of the form xxx.xxx.xxx.xxx, where each xxx is a number (represented in decimal) between 0 and 255. If no subnetting is being done, the value should be 255.0.0.0 for a Class A network, 255.255.0.0 for a Class B network, and 255.255.255.0 for a Class C network.
- ◆ **Default Gateway.** This parameter specifies the IP address for a gateway or a router where frames with destinations outside the current subnet should be sent. If your network is not part of an internetwork, or you do not want the hub to be accessible outside your local network, you can leave this field blank.
- ◆ **Send BOOTP Request Upon Power Up.** This parameter determines whether or not the hub should send out a BOOTP request when it is powered up. The BOOTP protocol allows IP addresses, network masks, and default gateways to be assigned from a central BOOTP server; if this option is set to “yes,” the hub will first look for a BOOTP server to provide it with this information before using local settings.

```

DFE-2600 Stackable Hub - TCP/IP Parameters Configuration Menu

Interface #<1      Media Type: Ethernet>

Current Setting
IP Address:      210.68.85.51
Subnet Mask:    255.255.255.0
Default Gateway: 210.68.85.126

System Restart Setting
IP Address      [210.68.85.51 ]
Subnet Mask    [255.255.255.0 ]
Default Gateway [210.68.85.126 ]

Send BootP Request Upon Power Up <No >

                                HELP      SAVE      EXIT

```

The default setting for all TCP/IP variables is 0.0.0.0.

Out-of-Band Management and Console Settings

You can use the Out-of-Band/Console Setting menu to choose whether to use the hub's RS-232 serial port for console management or for out-of-band TCP/IP communication using SLIP, and to set the baud rate used for SLIP communications.

The following fields can be set:

- ◆ **System Restart Out-of-Band Baud Rate.** This parameter determines the serial port baud rate that will be used the next time the hub is restarted. It applies only when the serial port is being used for out-of-band (SLIP) management; it does not apply when the port is used as a console port. Available speeds are 1200, 2400, 9600, and 19200 bits per second.
- ◆ **Out-of-Band Dial Up Phone Number.** This information is stored as a reference for the benefit of the system manager and does not cause the hub to dial out.
- ◆ **System Restart Serial Port Setting.** This parameter determines whether the serial port should be used for out-of-band (SLIP) management or for console management, starting from the next time the hub is restarted. It can be set to either "Console" or "Out-of-Band."

DFE-2600 Stackable Hub - Out-of-Band/Console Setting Menu

```
Out-of-Band Setting                Console Setting:

Protocol:                          SLIP
Baud Rate:                         9600      Baud Rate:      9600
Character Size:                     8        Character Size: 8
Stop Bit:                           1        Stop Bit:      1

System Restart Out-of-Band Baud Rate
<9600 >
Out-of-Band Dial Up Phone Number
[                                     ]

Current Serial Port Setting:        Console
System Restart Serial Port Setting <Console >

                                HELP      SAVE      EXIT
```

Software Update on Boot

The hub is capable of obtaining its boot-time configuration information, as well as updated versions of its internal firmware, using TFTP (the Trivial File Transfer Protocol) and BOOTP (the BOOTstrap Protocol). You can use the Software Update menu to control this feature.

The fields you can set on this menu are:

- ◆ **Software Update.** This parameter determines whether or not the hub will try to look for the configuration file over the network. If set to Disable, the parameters below become irrelevant.
- ◆ **Software Update Mode.** This variable can be set to either Network or Out-of-band. Determines whether the configuration file should be obtained through the Ethernet network or through the console port.
- ◆ **Boot Protocol.** This parameter can be set to either TFTP ONLY or BOOTP&TFTP. Applies only if the *S/W Update* control is enabled.

- ◆ **Boot Server IP Address.** This variable is the IP address of the TFTP server where the configuration file is located. This entry is used only if the *S/W Update Control* is enabled and your boot protocol is TFTP only; if you are using BOOTP&TFTP mode, or if *Send BOOTP Request on Power Up* is enabled, the address will be obtained from the BOOTP server.
- ◆ **Boot File Name.** The pathname of the configuration file on your TFTP server. If you are using D-View as your TFTP server, this is the pathname of the .CFG file on your hard disk. This entry is used only if your boot protocol is TFTP ONLY; if you are using BOOTP&TFTP mode, or if *Use BOOTP to get IP after start up* is enabled, the pathname will be obtained from the BOOTP server. For more information about the DFE-2600 series master hub configuration file, see *Appendix C, Boot Configuration File*.

```
DFE-2600 Stackable Hub - Software Update Menu

Software Update          <Disable>
Software Update Mode    <Network  >

Boot Protocol            <TFTP ONLY >
Boot Server IP Address   [210.68.85.36  ]
Boot File Name           [c:\dfe2600i.cfg  ]
Last Boot Server IP Address: 210.68.85.35

                                HELP      SAVE      EXIT
```

SNMP Information

The System Configuration Menu screen shows a variety of information about your hub, and allows you to set the System Name, System Location,

and System Contact. These settings can be retrieved from the hub using SNMP requests, allowing them to be used for network management purposes. Each of these fields is restricted to 64 characters:

- ◆ **System Name.** This parameter corresponds to the MIB-II object *sysName*, and is used to assign a name to the hub for administrative purposes. The hub's domain name is often used, provided a name has been assigned.
- ◆ **System Location.** This parameter corresponds to the MIB-II object *sysLocation*, and is used to indicate the physical location of the hub for administrative purposes.
- ◆ **System Contact.** This parameter corresponds to the MIB-II object *sysContact*, and is used to note the name and contact information of the person responsible for administering the hub.
- ◆ **Display Timeout.** An additional setting, the console time-out, may be used to automatically log out the console interface after a predetermined period of inactivity. This feature increases hub security by preventing access to the hub after the interface has been inadvertently left logged on. A setting of 0 disables this feature.

```
DFE-2600 Stackable Hub - System Configuration Menu

Mgmt Hardware Revision:      Rev. 01
Boot PROM Firmware Version: Ver. 2.22
Software Version:           Ver. 2.04
MAC Address:                 0080C80D308C

System Description:
D-Link Corp. DFE-2600 Dual Speed Stackable Hub SNMP/
System Name [                ]
System Location [            ]
System Contact [            ]

Console/Telnet Display Timeout in Minutes [60 ]

                                HELP      SAVE      EXIT
```

SNMP Traps

The hub sends out SNMP *traps* to network management stations whenever certain exceptional events occur, such as when the hub is powered on or when an SNMP request is made using an unknown community name. An SNMP trap sent to another network management site provides a warning about, for example, an attempted unauthorized access to the network or hub, or changes to a network hub's configuration that may effect other parts of the network. Traps are sent only to selected network management hosts. The hub allows up to four different hosts to receive traps from the system.

```
DFE-2600 Stackable Hub - SNMP Trap Manager Setting Menu

IP Address          SNMP Community String          Status
[                   ] [                   ] <Invalid>
[                   ] [                   ] <Invalid>
[                   ] [                   ] <Invalid>
[                   ] [                   ] <Invalid>

                                HELP      SAVE      EXIT
```

The following trap parameters can be set:

- ◆ **IP Address.** This parameter specifies the IP address of the network management station which will receive traps from the hub.
- ◆ **SNMP Community String.** This parameter specifies the SNMP community name to be included in the trap request.

-
- ◆ **Status.** This determines whether this trap entry is valid or invalid. You can delete an entry by changing its status to Invalid.

SNMP Security (Community Names)

SNMP (version 1) implements a rudimentary form of security by requiring that each request include a community name. A community name is an arbitrary string of characters used as a “password” to control access to the hub. If the hub receives a request with a community name it does not recognize, it will trigger an authentication trap, provided this feature has not been disabled.

The DFE-2600 series master hubs allow up to four different community names to be defined, and the access rights for each community can be separately set to either read only or read/write. The status for each string can be toggled to either valid or invalid. The community names *public* and *private* are defined by default; you can change these names in addition to adding others. You will need to coordinate these names with the community name settings you use in your network management system.

```
DFE-2600 Stackable Hub - SNMP Manager Setting Menu

SNMP Community String      Access Right      Status
[public                    ] <Read Only >    <Valid >
[private                   ] <Read/Write>     <Valid >
[                           ] <Read Only >    <Invalid>
[                           ] <Read Only >    <Invalid>

                                HELP      SAVE      EXIT
```

Adding and Deleting Users

Access to the console program, whether using the diagnostic port or TELNET, is controlled by user names and passwords. Up to three user names can be defined. One user, named **D-Link**, is defined by default; this user name can be removed if desired. However, the console program will not let you delete the currently logged-in user to prevent you from accidentally deleting all users with *Super User* privileges – making it impossible to change important hub settings.

Only users with *Super User* privileges can add and delete users.

Add a User

To add a new user, perform these steps:

1. Choose **User Account Change** from the main menu. The following screen will appear:

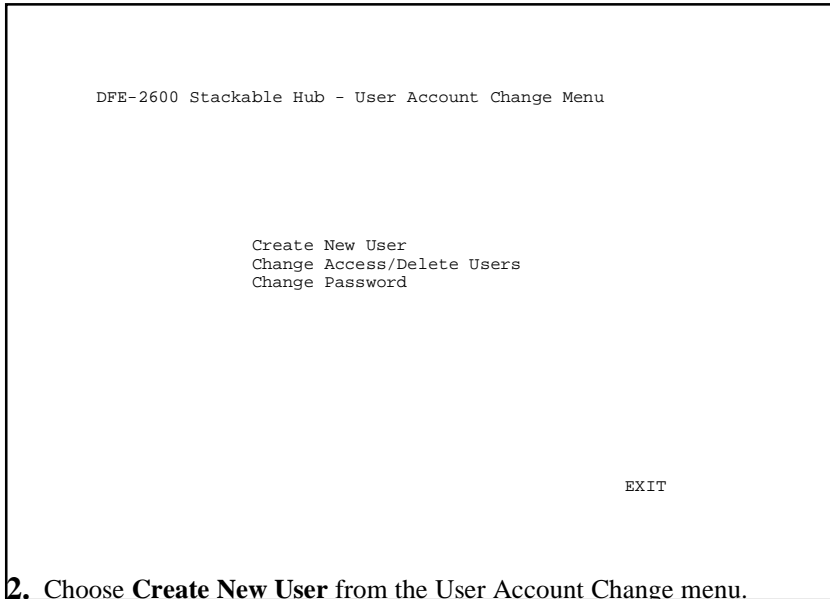

2. Choose **Create New User** from the User Account Change menu.

-
3. Enter the new user name, and assign an initial password. Determine whether the new user should have *Super User* or *General User* privileges.

```
DFE-2600 Stackable Hub - User Account Change : Create New User

User Name      [          ]
Password       [          ]
Confirm Password [          ]

Access Level   <Super User >

                                HELP      SAVE      EXIT
```

4. Choose **SAVE** and press <Enter> to let the user addition take effect.
5. Choose **EXIT** to leave the Create New User menu.

Delete a User

To delete a user, follow these steps:

1. Choose **User Account Change** from the main menu.
2. Choose **Change Access/Delete Users** from the User Account Change menu.

3. Toggle the **Status** field of the user you wish to remove to N/A. (To temporarily restrict a user's access to the hub console, you can toggle that user's Status to **Inactive**.)

```
DFE-2600 Stackable Hub - User Account Change : Delete Users

User Name      Access Level   Status         Delete
admin          <Super User > <Active >     <N/A>
D-Link         <Super User > <Active >     <No >
               <N/A         > <N/A         > <N/A>
```

HELP SAVE EXIT

4. Choose **SAVE** and press <Enter> to let the user deletion take effect.
5. Choose **EXIT** to leave the Delete Users menu.

Primary/Backup Master

The Primary/Backup Master Hub screen, accessible from the Network Monitoring menu, is used to display the stack management status of each master hub in the stack. Fields in this screen are for information only and cannot be changed. The group ID, primary/backup status, IP address, and MAC address for master hubs in the stack are displayed.

DFE-2600 Stackable Hub - Network Monitoring : Primary/Backup Master Menu

Group ID	Status	IP Address	MAC Address
1	Primary Master	210.68.85.51	0080C8112202

EXIT

Hub Stack Management

Several important hub parameters useful in the day-to-day management of the hub can be viewed and controlled using the Group Configuration and Port State menus.

Controlling Hubs in the Hub Stack

The Group Configuration Menu screen, found under the Network Monitoring menu, displays information about each of the hubs in the stack.

Note: *In this context, "Group" means "hub."*

The items displayed on this screen are:

- ◆ **Group ID.** This field indicates which hub is being displayed.
- ◆ **Group Serial Number.** Displays the hub's factory assigned serial number.
- ◆ **Group Position Number.** Displays the hub's stack position relative to the other hubs (1 is the highest in the stack, 5 the lowest).
- ◆ **Group Description.** This field gives a description of the given hub, showing its model number.
- ◆ **Group Role.** Shows what role the hub is currently playing in the hub stack (primary master, standby master, or slave).
- ◆ **Group Port Capacity.** This field shows the total number of network ports on the hub.

Note: When modules with additional ports are installed in DFE-2600 series hubs, the Port Capacity number will automatically adjust to reflect the added ports. The management software does not discriminate, any type of added or removed port will change the Port Capacity number.

-
-
- ◆ **Group Hardware Revision.** This field shows the design version of the hub hardware.
 - ◆ **Group Master Revision.** Displays the design version for master hubs.
 - ◆ **Group Status.** This field shows whether the hub is up-and-running or down.
 - ◆ **Group Last Oper Change.** This field shows the time when the hub was last added to or removed from the stack. The format is

hh:mm:ss.xx, with hh representing hours since the master hub was turned on, mm the minutes, ss the seconds, and xx representing 100ths of a second.

- ◆ **Group Slot (1).** Shows the status of module slot 1. If there is a module installed in slot 1, this field will display: MII, TP, FX, or Switch as determined by the type of module installed. If there is no module installed, the field will display “None.”
- ◆ **Group Slot (2).** Shows the status of module slot 2. If there is a module installed in slot 2, this field will display: MII, TP, FX, or Switch as determined by the type of module installed. If there is no module installed, the field will display “None.”
- ◆ **Group Isolate.** Provides control of the hub’s current network connection status and allows the system manager to manually isolate a particular hub as needed and reconnect it later. Toggling the field to “Isolate” separates the hub’s data connection from the other hubs. Toggling the field to “Reconnect” re-establishes the connection. See “Segmenting Hubs” earlier in this chapter for more information.

```
DFE-2600 Stackable Hub - Network Monitoring : Group Configuration Menu

Group ID (1-5) [1]
Group Serial Number:      623000B
Group Position Number:
Group Description:        DFE2624i
Group Role:               Primary Master
Group Port Capacity:      24
Group Hardware Revision:  Rev. 06
Group Master Revision:    Rev. 01
Group Status:             Up
Group Last Oper Change:   0:1:35.90
Group Slot (1):          Switch
Group Slot (2):          none

Group Isolate:           <Reconnect>

PREV GROUP  NEXT GROUP  HELP  SAVE  EXIT
```

You can use **PREV GROUP** and **NEXT GROUP** to display information about another hub, or you can enter the hub's Group ID number directly in the Group ID field.

Controlling Individual Ports

The Port State Menu, accessible from the Network Monitoring menu, allows you to view the status of individual ports and control their settings. The information displayed includes:

- ◆ **Group ID.** This field determines which hub's ports are displayed.
- ◆ **Port ID.** This field determines which port is displayed.
- ◆ **Connector Type.** This field shows the port's connector type.
- ◆ **Link Test.** This field displays Up if there is a station connected to the port; otherwise, it displays Down.
- ◆ **Link Test State.** This field displays Enable if the port's link status is to be auto-detected and displayed, otherwise it displays Disable. This variable is user configurable.
- ◆ **Receive Polarity.** This field always displays Normal if the hub is operating properly.
- ◆ **Auto Partition.** This field displays Yes if the port has been automatically partitioned off from the rest of the network due to excessive errors on the segment. The field displays No for normal operation.
- ◆ **Admin State.** This toggle determines whether the port should be enabled or disabled (manually partitioned). Setting the Admin State to Disabled will isolate the port from the rest of the network. This variable is user configurable.
- ◆ **Port Speed.** This field displays the port's current operating speed (100M or 10M) relative to the speed of the device connected to it.

-
- ◆ **Speed Capability.** This field displays the port's current speed setting, Auto for auto-detect/correct, 100M for 100Mbps connections only, or 10M for 10Mbps connections only. This variable is user configurable.

```
DFE-2600 Stackable Hub - Network Monitoring : Port State Menu

Group ID(1-8) [1]          Port ID(1-24) [1 ]
Connector Type: UTP

Port Status                Port State

Link Test:                Up          Link Test State: <Enable >
Receive Polarity:        Normal
Auto Partition:          On          Admin State:    <Enable >
Port Speed:              100M       Speed Capability: <Auto  >

PREV GROUP  NEXT GROUP  PREV PORT  NEXT PORT  HELP  SAVE  EXIT
```

You can use **PREV GROUP** and **NEXT GROUP** to switch to another hub, or **PREV PORT** and **NEXT PORT** to switch to another port. You can also enter the port's Group ID and Port ID numbers to go directly to a different port.

Monitoring the Hub Stack

The hub supports several monitoring functions, allowing you to keep statistics on the operation of each port, each hub, and the entire network segment, as well as to monitor the addresses of the packets received at each port.

Displaying Port and Group Statistics

The hub stack collects network transmission statistics for each port, and each hub (group) in the stack. Statistics collected for segments are tabulated differently and are explained in the next section. You can choose which to view from the Statistics menu, accessible under the Network Monitoring menu.

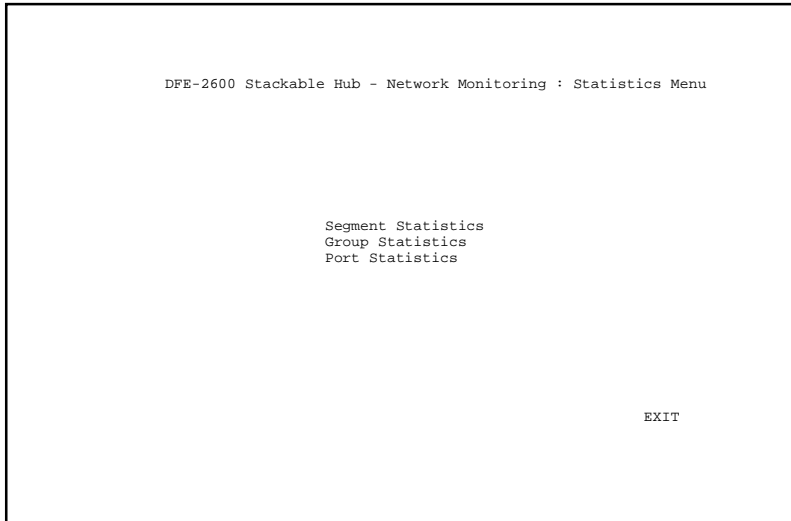

The data categories provided for both port and group statistics are the same. They are:

- ◆ **Frames Too Long.** This statistic counts frames longer than the 1518-byte (octet) limit set by the Ethernet standard. This problem is likely caused by software errors.
- ◆ **Very Long Events.** This statistic counts events where a signal is received that is longer than the jabber lockup protection timer setting. A high count in this field may indicate noise on the line or a bad Ethernet interface.

-
- ◆ **Short Events.** This statistic counts events where less than 10 bytes are received and the frame start delimiter is invalid, or where the start frame delimiter is valid but less than 2 bytes are received. This type of error may indicate noise on the line.
 - ◆ **Late Events.** This statistic counts collisions that occur at or after the 64th byte (octet) in the frame. A high count here may indicate that delays on your Ethernet are too long, and you have either exceeded the repeater count or cable length specified in the Fast Ethernet standard.
 - ◆ **Runt Frames.** This statistic counts frames shorter than the 64-byte (octet) minimum defined by the Fast Ethernet standard. Runts are often caused by collisions.
 - ◆ **Collisions.** This statistic counts collisions on the Ethernet segment.
 - ◆ **FCS Errors.** This statistic counts otherwise valid frames that fail the CRC check.
 - ◆ **Alignment Errors.** This statistic counts otherwise valid frames that did not end on a byte (octet) boundary.
 - ◆ **Readable Frames.** This statistic counts valid frames.
 - ◆ **Multicast.** This statistic counts the number of good multicast packets received. Multicast events are messages sent from one node to multiple nodes on the segment.
 - ◆ **Broadcast.** This statistic counts the number of good broadcast packets received. Broadcast events are messages sent to all nodes on the segment.
 - ◆ **Auto Partitions.** This statistic counts events where the port was partitioned off from the rest of the network due to excessive collisions or cabling problems.
 - ◆ **DRM (Data Rate Mismatch).** This statistic counts events where there is a frequency mismatch between the received signal and the

hub's internal clock. A high count in this field may indicate a hardware problem in the hub or in an Ethernet interface.

- ◆ **SA Changes.** This statistic counts the number of times the source address has changed.
- ◆ **Isolates** (only for 100Mbps connections). Counts the number of times a port auto isolates.
- ◆ **SymbolError** (only for 100Mbps connections). Counts the number of times a received packet contained symbol errors. Only one symbol error is counted per packet regardless of the number of symbol errors within the packet.
- ◆ **Total Errors.** This statistic is the sum of the FCS Error, Alignment Error, Too Long Frame, Short Event, Late Event, Very Long Event, and Data Rate Mismatch counters.
- ◆ **Readable Octs.** This statistic counts the total number of bytes (octets) included in valid (readable) frames.

```

DFE-2600 Stackable Hub - Network Monitoring : Port Statistics

Current Group ID: 1      Current Port ID: 9
      Pkts      Pkts/Sec      Pkts      Pkts/Sec
Frames Too Long: 0      0      Readable Frames: 484447      0
Very Long Events: 0      0      Multicast: 7393      0
Short Events: 0      0      Broadcast: 305460      0
Late Events: 0      0      Auto Partition: 0      0
Runt Frames: 2632      0      DRM: 0      0
Collision: 8514      0      SA Changes 319965      0
FCS Errors: 395      0      Isolates: 0      0
Alignment Errors: 9      0      SymbolError: 0      0

Total Errors:      Errs      Errs/Sec      Readable Octs:      Octs      Octs/Sec
                  404      0      105350920      0

Next Monitoring Group ID [1]
Next Monitoring Port ID [9 ]

PREV GROUP  NEXT GROUP  PREV PORT  NEXT PORT  CLEAR COUNTER  EXIT
    
```

You can use **PREV GROUP**, **NEXT GROUP**, **PREV PORT**, and **NEXT PORT** to switch hubs or ports. **CLEAR COUNTER** resets all counters back to zero.

NOTE: *The CLEAR COUNTER action only resets the counters for the statistics display; the underlying counters (i.e., MIB variables) are not cleared.*

Displaying Segment Statistics

The hub stack collects network transmission statistics for each segment in the stack. You can choose to view them from the Statistics menu, accessible under the Network Monitoring menu.

- ◆ **StatsPkts.** This statistic displays the number of packets received from the network, including error packets.
- ◆ **BroadcastPkts.** This statistics counts the number of good broadcast packets received on the segment.
- ◆ **MulticastPkts.** This statistics counts the number of good multicast packets received on the segment.
- ◆ **CRCAlignErrors.** This statistic counts the number of valid length packets (64 to 1518 bytes) that had a bad Frame Check Sequence (FCS).
- ◆ **UndersizePkts.** This statistic counts the number of well-formed packets that were smaller than 64 octets.
- ◆ **OversizePkts.** This statistic counts the number of well-formed packets that were longer than 1518 octets.

- ◆ **Fragments.** This statistic counts the number of ill-formed packets less than 64 octets and all events without a start-of-frame delimiter regardless of their length.
- ◆ **Jabbers.** This statistic counts the number of jabber events on the segment.

```
DFE-2600 Stackable Hub - Network Monitoring : Segment Statistics

Current Segment ID: 1

StatsPkts:      Pkts      Pkts/Sec      64 Octets:      Pkts      Pkts/Sec
BroadcastPkts: 284057    0             65-127 Octets: 114508    0
MulticastPkts: 6884      0             128-255 Octets: 215763    0
CRCAlignErrors: 47         0             256-511 Octets: 12529     0
UndersizePkts: 0          0             512-1023 Octets: 4197      0
OversizePkts:  0          0             1024-1518 Octets: 75747     0
Fragments:     677        0
Jabbers:       1          0
Collisions:    673        0

                               Octets      Octets/Sec
StatsOctets:    187814091  0
Total Octets:   191996500  0

Next Monitoring Segment ID [1]

PREV SEG      NEXT SEG      CLEAR COUNTER      EXIT
```

- ◆ **Collisions.** This statistic counts the number of collisions on the segment.
- ◆ **64 Octets.** This statistic displays the number of packets (both good and bad) that were 64 octets long.
- ◆ **65-127 Octets.** This statistic displays the number of packets (both good and bad) that were 65 - 127 octets long.
- ◆ **128-255 Octets.** This statistic displays the number of packets (both good and bad) that were 128 - 255 octets long.

-
- ◆ **256-511 Octs.** This statistic displays the number of packets (both good and bad) that were 256 - 511 octets long.
 - ◆ **512-1023 Octs.** This statistic displays the number of packets (both good and bad) that were 512 - 1023 octets long.
 - ◆ **1024-1518 Octs.** This statistic displays the number of packets (both good and bad) that were 1024 - 1518 octets long.
 - ◆ **StatsOcts.** This statistic displays the number of data octets including those in bad packets and octets in FCS fields but does not include preamble or other framing bits.
 - ◆ **Total Octs.** This statistic displays the total number of octets contained in valid frames received on this segment.

Node Tracking

The Node Tracking screen displays the origination MAC addresses of packets received by each node connected to the hub for the last 12 receives.

```
DFE-2600 Stackable Hub - Network Monitoring : Node Tracking Information

Group ID: 1      Port ID: 1
Source MAC                               Source MAC

PREV GROUP  NEXT GROUP  PREV PORT  NEXT PORT  EXIT
```

Group and port can be selected by entering the appropriate number(s) in the Group ID and Port ID fields or using the navigation commands at the bottom of the screen.

Per-Port Intrusion Security

Each port on this hub can have intrusion security enabled. Intrusion security prevents unauthorized individuals from accessing the network. Through the network management software, Ethernet addresses that represent authorized users can be assigned to each hub port. If a packet using a source address other than those used by authorized users is received by a port, the port is disabled and the network manager is notified.

Bridge Information

The bridge information screen allows the network administrator to view the install and operation status of all bridging modules within a segment. To avoid non-terminating network data loops, only one bridging module at a time can be active. The hub stack management software always enables the module installed in the highest hub in the stack. The management program can only test for the presence or absence of an installed bridge and not whether it is functional. Under the Bridge Present column, "N/A" indicates no bridging module present in that hub.

```
DFE-2600 Stackable Hub - Network Monitoring : Bridge Information
```

Hub ID	Bridge Present	Bridge Status
1	Bridge	Enable
2	N/A	Disable
3	N/A	Disable
5	N/A	Disable

```
EXIT
```

Resetting the Hub

You can use the console program to reset the hub stack, either doing a system reset (which restarts the hubs and is identical to powering them off and back on again) or a factory reset (which resets the master hub, reverts all of its parameters back to their factory default values, and restarts the entire hub stack).

Important Note: *If it is necessary for you to power-off the hub (or hub stack) and then re-start it instead of using the reset functions, the hub MUST BE POWERED-OFF for a MINIMUM of TEN SECONDS.*

If the hub stack has a backup master, the time required to complete the reset process will be longer than without one. Generally, a stack reset should be complete within about two minutes.

System Reset

To perform a system reset, follow these steps:

1. Choose **System Reset** from the main menu. The following confirmation message will appear:

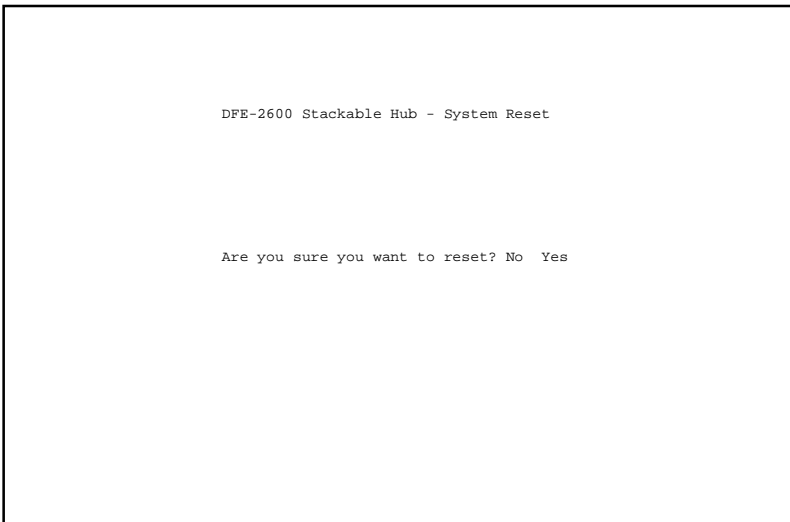

2. Move the cursor to **Yes** to confirm the reset and press `<Enter>`. After a few seconds delay, the hub should restart.

Factory Reset

Before performing a factory reset, be absolutely certain that this is what you want to do. Once the reset is done, all of the master hub's stored set-

tings (including TCP/IP parameters, SNMP parameters, the enabled/disabled settings of ports, etc.) will be erased and restored to their factory default settings.

1. Choose **Factory Reset NVRAM to Default Value** from the main menu. A confirmation message similar to that for the System Reset will appear.
2. Move the cursor to **Yes** to confirm the reset and press <Enter>. After a few seconds delay, the hub should restart, and all of its parameters will revert to their default values.

Note: Doing a factory reset to the Primary Master also resets the Backup Master variables except for the Backup Master IP address.

A

CABLES AND CONNECTORS

100BASE-TX Ethernet Cable and Connectors

- ◆ Cable characteristics: 0.4 to 0.6 mm (22 to 26 AWG) 4-pair (only two pairs/four wires are used for 100BASE-TX); Category 5 unshielded twisted-pair or EIA/TIA-568 compliant, 100-ohm shielded twisted-pair
- ◆ Maximum segment length: 100 meters
- ◆ Maximum network diameter: 205 meters
- ◆ Connectors: RJ-45

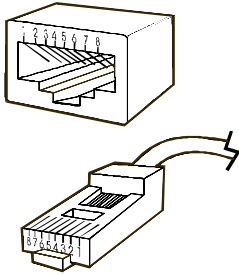

Straight Twisted-Pair Cable Pinouts		
Contact	MDI-X Signal	MDI Signal
1	RD+ (receive)	TD+ (transmit)
2	RD- (receive)	TD- (transmit)
3	TD+ (transmit)	RD+ (receive)
4	Not used	Not used
5	Not used	Not used
6	TD- (transmit)	RD- (receive)
7	Not used	Not used
8	Not used	Not used

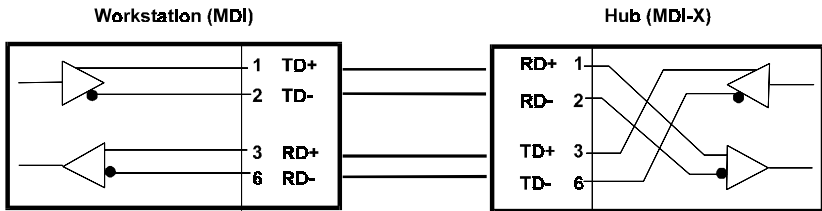

Crossover Cables

When cascading or connecting the hub to another switch, bridge, or hub through the UTP port, a modified crossover cable is necessary. With a crossover cable, two pairs of wires are switched at one connector end. Carry out the following steps to create a customized, crossover twisted-pair cable:

1. Leave one end of the cable as is, with the RJ-45 connector intact. The wiring at just one end of the cable needs to be modified.

- At the other end of the cable, connect wires 1 and 2 to contacts 3 and 6 respectively. Likewise, connect wires 3 and 6 to contacts 1 and 2. Refer to the following diagram:

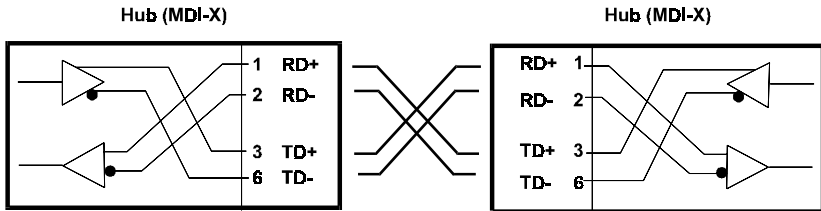

Diagnostic Port Specifications

This section provides supplemental information that concerns diagnostic port connections. Information on RS-232 DB-25 connectors is provided for connections with 25-pin console devices.

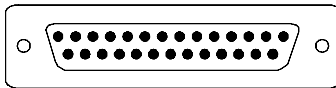

DB-25

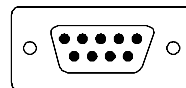

DB-9

RS-232 (DB9) Pin Specification

The RS-232 serial port of the hub uses a 9-pin female connector. The port can be connected to a VT-100 terminal, a PC, or a workstation emulating a VT-100 terminal. The figures below show the connections necessary for connection to 9-pin and 25-pin RS-232 devices.

Console Port
(DCE, DB-9)

Terminal/PC Serial Port
(DTE, DB-9)

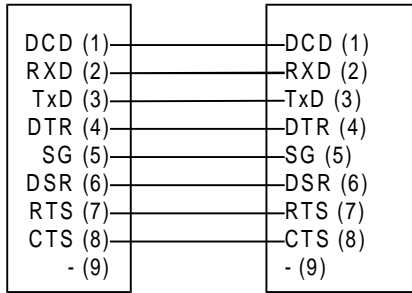

Console Port
(DCE, DB-9)

Terminal/PC Serial Port
(DTE, DB-25)

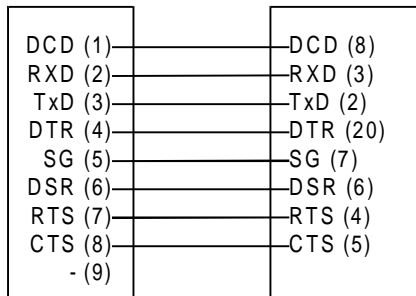



BOOT CONFIGURATION FILE

DFE-2600 series master hubs support a powerful configuration file which allows many of the hub stack's configuration parameters to be stored on a centralized server. When the master hub starts up, it can be configured to read its configuration file from the server using the TFTP protocol. This can make it easier to manage a large number of hub stacks, since all of the configuration parameters for all of the hubs can be managed in a single place.

The configuration file is a text file, usually stored on the server with a .CFG extension. It can be up to 10 KB long. Lines beginning with # are considered comments which are ignored by the hub. All other lines are commands, which are interpreted by the master hub.

The configuration file commands accepted by the hub are:

◆ *sysname string*

Takes *string* as the System Name, corresponding to the SNMP MIB-II object sysName. This field is used to assign a name to the hub for administrative purposes. The hub's fully qualified domain name is often used, provided a name has been assigned. The *string* can be up to 64 characters long.

◆ *syscontact string*

Takes *string* as the System Contact, corresponding to the SNMP MIB-II object `sysContact`. This field is used to give the name and contact information of the person responsible for the hub. The *string* can be up to 64 characters long.

◆ `syslocation string`

Takes *string* as the System Location, corresponding to the SNMP MIB-II object `sysLocation`. This field is used to indicate the physical location of the hub for administrative purposes. The *string* can be up to 64 characters long.

◆ `baud-rate n`

Sets the serial port communication rate used when the port is being used in out-of-band mode. Legal values for the parameter *n* are: 2400, 4800, 9600, and 19200.

◆ `2600h-image string`

Takes *string* (which may be up to 64 characters long) as the filename of the image file to be downloaded from the TFTP server. When the hub boots, it will load the given image file from the server and execute it. This command may be used to update the hub's software when a new version is available from D-Link.

◆ `ip-netmask mask`

Uses *mask* as the network mask for the local network. For a Class C network with no subnetting, the netmask should be 255.255.255.0.

◆ `ip-default address`

Uses *address* as the hub's default gateway address. The *address* should be in the form xxx.xxx.xxx.xxx, where each xxx is a number between 0 and 255.

◆ `auth-trap enable/disable`

Enables or disables authentication failure traps for invalid SNMP community names. The argument for this field is either `enable` or `disable`.

◆ `clear-SNMP-comm-table`

Clears the hub's SNMP community name table.

◆ `SNMP-community community permissions`

Adds a community to the hub's list of SNMP communities, with access permissions. Four entries is the maximum allowed. The community name can be up to 32 characters long. Permissions can be read for read-only community access, or write for read-write community access.

◆ `clear-ip-trap-manager-table`

Deletes all entries from the hub's trap manager list.

◆ `ip-trap-manager address community`

Adds the host at *address* to the hub's SNMP trap manager list. Four entries is the maximum allowed. Traps sent to the host will use the community name variable *community*, which may be up to 32 characters long.

◆ `telnet-idle-time n`

Sets the hub's maximum allowed console interface idle time to *n* minutes.

◆ `node-age-time n`

Sets the hub's node age timer to *n* seconds. Node aging is used with the hub's security option to determine how long to keep entries in the node tracking table.



SPECIFICATIONS

General

Standards: IEEE 802.3 10BASE-T Ethernet repeater, IEEE 802.3u 100BASE-TX Fast Ethernet repeater (Class II); ANSI X3T9.5 Twisted-Pair Transceiver

Topology: Star

Protocol: CSMA/CD

Network Data Transfer Rate: Fast Ethernet, 100Mbps; Ethernet, 10Mbps

Number of Ports: 16 (DFE-2616i / DFE-2616ix / DFE-2616 / DFE-2616x) or 24 (DFE-2624i / DFE-2624ix / DFE-2624 / DFE-2624x) 10BASE-T / 100BASE-TX ports

Network Media: Ethernet: Category 3 or better UTP cable, 100m maximum; Fast Ethernet: UTP/STP Cat 5, 100-ohm twisted-pair (100m maximum) for hub-to-station links; UTP Cat 5, 100-ohm UTP/STP (5m maximum) for hub-to-hub linking

Hub-to-Hub Cascading

Number of Daisy-Chained Hubs: Maximum of 5 hubs per stack

Daisy-Chain Port: MiniSCSI-type connector × 2

Daisy-Chain Cable: SCSI-type cable (supplied)

LED Indicators

Hub Status: Power, 10Mbps collision, 100Mbps collision, 10Mbps utilization, 100Mbps utilization, module link

Port Status (per port): Link/Activity, Auto Partition/Manual Partition, Speed (10/100Mbps)

Environmental and Physical

Power Supply: 100 to 240 VAC, 50 or 60 Hz internal universal power supply

Power Consumption:	DFE-2616 =	25.5 watts maximum
	DFE-2616x =	27 watts maximum
	DFE-2624 =	34 watts maximum
	DFE-2624x =	35 watts maximum
	DFE-2616i =	31 watts maximum

DFE-2616ix = 32.5 watts maximum

DFE-2624i = 39 watts maximum

DFE-2624ix = 40 watts maximum

Dimensions: 441mm × 237mm × 55mm (1.25 U height), 19-inch rack-mountable

Weight: 3.87kg (8.53 lbs.)

Operating Temperature: -10 to 55°C

Storage Temperature: -25 to 55°C

Humidity: 5% to 95% non-condensing

DC Fan: 40mm × 40mm

Emissions: FCC Class A, CE, VCCI Class A, C-Tick

Safety: UL, CSA, CE Mark, TÜV/GS

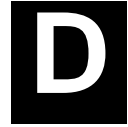

GLOSSARY

Please note that the terms in this glossary are defined according to their usage in this document and as part of the field of computer networking. Any meaning or usage outside of these specific areas may not be included and is not necessarily implied.

#

- | | |
|-------------------|---|
| 100BASE-TX | 100Mbps Ethernet LAN communications standard set by the IEEE (in standard 802.3u); also called “Fast Ethernet.” |
| 100Mbps | 100 million bits per second; an expression of transmission speed in a network. |
| 10BASE-T | The original Ethernet LAN communications standard set by the IEEE (in standard 802.3); a 10Mbps standard. |
| 10Mbps | 10 million bits per second; an expression of transmission speed in a network. |

A

- | | |
|----------------|--|
| Address | A number, set of numbers, or name which uniquely identifies a computer, network device, or network resource. |
|----------------|--|

B

- Bandwidth** The range of frequencies available across a communications channel; in one sense, the “size” of the communications channel.
- BOOTP** The BOOTstrap Protocol, a method network devices can use to obtain TCP/IP configuration information from a central location on startup.
- Bridge** A LAN device used to connect two different LANs so that packets can be transmitted from one to the other. A bridge works on a low level, and does not take higher-level protocols into consideration. In this document and the hub management software, switching modules are most often referred to as bridges.

C

- Cascading** The practice of connecting identical or similar LAN devices such as hubs together directly so that they function as one device. A collection of cascaded devices is often called a stack.
- Category 3, 4, 5** Communication cabling standards referring to the quality of the transmission medium and whether or not the cable includes transmission leakage shielding.
- Collision** Simultaneous data transmission on a network medium, resulting in a garbled (and unreadable) transmission. See “CSMA/CD.”
- Collision Domain** A section of a network isolated from other sections by a switch, bridge, or hub that detects and resolves collisions locally so that there is less impact on the entire network.

Crossover Cable A type of twisted-pair cable in which the wires at one end have been reversed in order to match pinouts on a hub or switch.

CSMA/CD Carrier Sense Multiple Access with Collision Detection; a network communications protocol in which each transmission source (i.e., station, server, switch, etc.) monitors the main data channel for traffic before and during transmission, postponing transmission when the data channel is in use.

D

Duplex (full & half) The transmission of data over a network in both directions. Full-Duplex (FDX) is simultaneous transmission of data over a network channel in both directions. Half-Duplex (HDX) is transmission in both directions but one at a time, not simultaneous.

E

Ethernet A particular type of LAN described in a standard (802.3) established by the IEEE, with 10Mbps data transmission.

F

Fast Ethernet An extension of Ethernet LAN (defined in standard 802.3u) to allow 100Mbps transmissions.

H

Hub The central device in a star-topology LAN used to connect each station to the network.

I

IEEE Institute of Electrical and Electronics Engineers, an accredited professional group of scientists and engineers who help set standards for LAN communications technology.

In-band Communications with a network device using the network medium itself. Contrast with “Out-of-band.”

J

Jabber Malfunction of a network device wherein it continuously transmits random data.

L

LAN Local Area Network, an interconnected set of computers and other devices.

LED Light Emitting Diode – an electronic device that lights up when electricity is passed through it. LEDs are commonly used for status indicators on electronic devices.

M

Mbps Megabits per second; millions of bits per second.

MIB Management Information Base; a well-defined collection of statistics and control variables accessible using SNMP.

O

Out-of-band Communications with a network device using some medium other than the network itself.

P

Packet An addressed segment of data transmitted on a network.

Preamble Data bits at the beginning of each block of data, used for synchronization.

R

Repeater LAN signal regenerator. An Ethernet hub is a type of repeater.

S

Segment Part of an Ethernet or other network on which all traffic is common to all nodes. See “Collision Domain.”

SNMP The Simple Network Management Protocol; an industry-standard protocol for remotely monitoring and controlling network devices from a Network Management System (NMS). SNMP requests are usually transmitted using TCP/IP, though other means are possible.

T

TCP/IP Transmission Control Protocol/Internet Protocol; a suite of transport and network layer communications protocols.

- Telnet** Terminal emulation for the TCP/IP protocol suite, used for interacting with remote computers and devices.
- TFTP** Trivial File Transfer Protocol; a low-overhead protocol for file transmission over TCP/IP networks. Often used for obtaining device configuration files or bootstrap image files.
- Trap** An SNMP request that managed network devices send to network management stations, to inform them that some problem has been detected.
- Twisted-pair** Wire such as is commonly used with telephones consisting of pairs of copper wire usually terminating in an RJ-45 or RJ-11 connector.

U

- UTP/STP** UTP – unshielded twisted-pair, twisted pair wire without interference shielding. STP – shielded twisted-pair, twisted-pair wire with shielding.

INDEX

I

100BASE-TXxii, 1- 8, 21, 75, 83, 87
100Mbps..... 1-6, 12, 18-19, 25, 28, 32, 63, 67, 83, 84, 87, 90
10BASE-T 1, 2, 6, 7, 21, 25, 83, 87
10Mbps..... 1-6, 12, 18, 19, 25, 32, 63, 83, 84, 87, 89

B

backup master3, 40
BOOTP..... 39, 48, 50, 51, 88

C

cascade12, 39
Category 5 2, 6, 25, 28, 75
CEvi, 85
Class I..... 7
Class II 2, 7, 8, 25, 83
collisions.....3, 18, 20, 34, 35, 66, 69, 89
configuration file..... xii, 39, 40, 51, 79
console program..... 22, 27, 37, 47, 56, 72
conventions..... 38
crossover..... 11, 29, 30, 34, 76
CSMA/CD 6, 83, 88, 89

D

diagnostic port 22-27, 37, 47, 56, 77
DIP switch 34, 36
disable 3
D-View 9, 21, 27, 37, 40, 47, 51

E

EIA..... 7, 13, 14, 75
errors 20, 66, 67

F

Fast Ethernet..... i, xi, xii, 1-7, 18, 20, 25, 28, 30, 33, 34, 83, 87, 90
FCC vi, 85
Fiber Optic..... 33
front panel xii, 3, 14, 17

H

hub ID 3
Hub Stack 59, 64

I

IEEE 802.3 1, 2, 6, 83
IN v, 12, 23
installation 9, 13, 31
IP address 27, 39, 40, 47, 48, 51, 54, 58

L

LED..... xii, 3, 11, 17, 20, 33-35, 84, 90
link 3, 19, 20, 25, 29, 33, 34, 84

M

MAC address 58
master xii, 2, 3, 9, 12, 19-27, 32, 37-43, 51, 55-61, 72, 74, 79
MII 4
module..... 2-5, 12, 19, 31-35, 84

N

Navigation 38
network management 3, 21, 27, 37-40, 47, 52-55, 71, 92

O

OUT v, 12, 23

P

partition	3, 20, 21
password	43-46, 55, 57
port state	20
POST	39
power	3, 4, 9, 13, 15, 18, 24, 84
Primary Master	41
PROM	40

R

Rear Panel	11
Receive	20
RJ-45	3, 6, 75, 76, 92

S

security	43, 44, 53, 55, 71, 82
slave	19
SLIP	47-50
SNMP	3, 21, 27, 37, 47, 52-55, 74, 79-81, 91, 92
specifications	xii, 2
stack	1-5, 8-13, 19-24, 32, 84, 88
STP	6, 25, 28, 83, 92
straight-through	11, 28-30
subnet mask	39, 48
<i>Super User</i>	44, 46, 56, 57

T

TCP/IP	26, 37, 40, 47, 49, 74, 88, 92
TELNET	22, 26, 27, 37, 47, 56
TFTP	39, 40, 50, 51, 79, 80, 92
Topology	6, 83

U

Uplink	3, 11, 29, 30, 31
utilization	3, 19, 84
UTP	6, 25, 28, 76, 83, 92

V

VCCIvi, 85
VT-100 26, 27, 40, 77

D-Link[®] Offices

D-Link U.S.A.

53 Discovery Drive
Irvine, CA 92618 USA
TEL: 1-714-788-0805
FAX: 1-714-753-7033
BBS: 1-714-455-1779
E-Mail: tech@dlink.com
Web: www.dlink.com

D-Link Canada

2180 Dunwin Drive, Unit # 6
Mississauga, Ontario, L5L 5M8
Canada
TEL: 1-905-828-0260
FAX: 1-905-828-5669
BBS: 1-965-279-8732
E-Mail: techsup@dlinknet.com
Web: www.dlinknet.com
FTP: ftp.dlinknet.com

D-Link Australia

Unit 16, 390 Eastern Valley Wy
Roseville, NSW 2069
Australia
TEL: 61-2-9417-7100
FAX: 61-2-9417-1077
E-Mail: info@dlink.com.au
Web: www.dlink.com.au

D-Link New Zealand

203A Hurstmere Road
Takapuna, Auckland
New Zealand
TEL: 64-9-488-0502
FAX: 64-9-488-0565
E-Mail: winner@pcnet.co.nz

D-Link Europe (U.K.)

D-Link House, 6 Garland Road
Stammore, London HA7 1DP
U.K.
TEL: 44-181-235-5555
FAX: 44-181-235-5500
BBS: 44-181-235-5511
E-Mail: info@dlink.co.uk
Web: www.dlink.co.uk

D-Link Germany

Bachstrae 22, D-65830 Kriftel
Germany
TEL: 49-6192-97110
FAX: 49-6192-971111
BBS: 49-6192-971199
Info: 0130-7250-00 (toll free)
Help: 0130-7250-40 (toll free)
Web: www.dlink.de

D-Link France

Le Florilege #2, Allee de la
Fresnerie
78330 Fontenay Le Fleury
France
TEL: 33-1-3023-8688
FAX: 33-1-3023-8689
Web: www.dlink-france.com

D-Link Sweden

World Trade Center
P. O. Box 70396
107 24 Stockholm
Sweden
TEL: 46-8-700-6211
FAX: 46-8-219-640
E-Mail: info@dlink.se

D-Link Denmark

Naverland 2 DK-2600
Glostrup Copenhagen
Denmark
TEL: 45-43-969-040
FAX: 45-43-424-347

D-Link Italy

Via Nino Bonnet n. 6
20154 - Milano, Italy
TEL: 39-2-2900-0676
FAX: 39-2-2900-1723

D-Link Japan

10F, 8-8-15 Nishigotanda
Shinagawa-ku
Tokyo, 141
Japan
TEL: 81-3-5434-9678
FAX: 81-3-5434-9868
Web: www.d-link.co.jp

D-Link China

15th Floor, Science
& Technology Tower
Haidian District
No. 11, Baishiqiao Road
Beijing 100081
China
TEL: 86-10-6846-7106-9
FAX: 86-10-6846-7110
Web: www.dlink.co.cn

D-Link Singapore

1 International Business Park
#03-12 The Synergy
Singapore 609917
TEL: 65-774-6233
FAX: 65-774-6322
BBS: 65-774-4787
E-Mail: info@dlink.com.sg

D-Link India

Plot No.5, Kurla-Bandra
Complex Rd.
Off Cst Rd., Santacruz (E)
Bombay - 400 098
India
TEL: 91-22-617-2478
FAX: 91-22-617-2476

D-Link Taiwan

2F, No.233-2 Pao-Chiao Rd

Hsin-Tien, Taipei
Taiwan, R.O.C.
TEL: 886-2-2916-1600
FAX: 886-2-2914-6299
BBS: 886-2-2910-1835
Web: www.dlink.com.tw

Registration Card

Print, type or use block letters.

Your name: Mr./Ms _____
 Organization: _____ Dept. _____
 Your title at organization: _____
 Telephone: _____ Fax: _____
 Organization's full address: _____

 Country: _____
 Date of purchase (Month/Day/Year): _____

Product Model	Product Serial No.	* Product installed in type of computer (e.g., Compaq 486)	* Product installed in computer serial No.

(* Applies to adapters only)

Product was purchased from:

Reseller's name: _____
 Telephone: _____ Fax: _____
 Reseller's full address: _____

Answers to the following questions help us to support your product:

- 1. Where and how will the product primarily be used?**
Home Office Travel Company Business Home Business Personal Use
- 2. How many employees work at installation site?**
1 employee 2-9 10-49 50-99 100-499 500-999 1000 or more
- 3. What network protocol(s) does your organization use ?**
XNS/IPX TCP/IP DECnet Other _____
- 4. What network operating system(s) does your organization use ?**
D-Link LANsmart Novell NetWare NetWare Lite SCO Unix/Xenix PC NFS 3Com 3+Open
Banyan Vines DECnet Pathwork Windows NT Windows NTAS Windows '95
Other _____
- 5. What network management program does your organization use ?**
D-View HP OpenView/Windows HP OpenView/Unix SunNet Manager Novell NMS
NetView 6000 Other _____
- 6. What network medium/media does your organization use ?**
Fiber-optics Thick coax Ethernet Thin coax Ethernet 10BASE-T UTP/STP
100BASE-TX 100BASE-T4 100VGAnyLAN Other _____
- 7. What applications are used on your network?**
Desktop publishing Spreadsheet Word processing CAD/CAM
Database management Accounting Other _____
- 8. What category best describes your company?**
Aerospace Engineering Education Finance Hospital Legal Insurance/Real Estate Manufacturing
Retail/Chainstore/Wholesale Government Transportation/Utilities/Communication VAR
System house/company Other _____
- 9. Would you recommend your D-Link product to a friend?**
Yes No Don't know yet
- 10. Your comments on this product?**

PLEASE
PLACE STAMP
HERE

TO: _____

D-Link®